

STATE OF ILLINOIS  
DEPARTMENT OF TRANSPORTATION

F.A.P. RTE	SECTION	COUNTY	TOTAL SHEETS	SHEET NO.
885	106RS-6	UNION	22	1
		ILLINOIS	CONTRACT NO. 78A71	

FOR INDEX OF SHEETS, SEE SHEET NO. 3

**2023 TRAFFIC DATA**

ADT=5,000 WITH 18.50% TRUCKS

**STATION EQUATIONS**

EQN STA 247+91.25 BK = STA 248+00.42 AH  
EQN STA 566+60.70 BK = STA 566+74.00 AH

**PROPOSED  
HIGHWAY PLANS**

FAP ROUTE 885 (IL 146)  
SECTION 106RS-6  
NHPP-STP-K3UJ(878)  
RESURFACING  
UNION COUNTY

C-99-097-24



**TOWNSHIPS  
STOKES**

**LOCATION 2**  
STA. 279+21.76 TO 321+00.00

**LOCATION 1**  
STA. 248+00.42 AH TO 279+21.76

**LOCATION 3**  
STA. 321+00.00 TO 566+60.70 BK

POSTED SPEED : 55 MPH

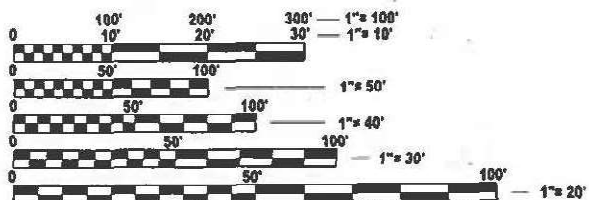

FULL SIZE PLANS HAVE BEEN PREPARED USING STANDARD ENGINEERING SCALES. REDUCED SIZED PLANS WILL NOT CONFORM TO STANDARD SCALES. IN MAKING MEASUREMENTS ON REDUCED PLANS, THE ABOVE SCALES MAY BE USED.

J.U.L.I.E.  
JOINT UTILITY LOCATION INFORMATION FOR EXCAVATION  
1-800-892-0123  
OR 811

T12S

**PROJECT BEGINS**  
STA. 247+91.25 BK =  
STA. 248+00.42 AH

**PROJECT ENDS**  
STA. 566+60.70 BK =  
STA. 566+74.00 AH

UNION/JOHNSON  
COUNTY LINE

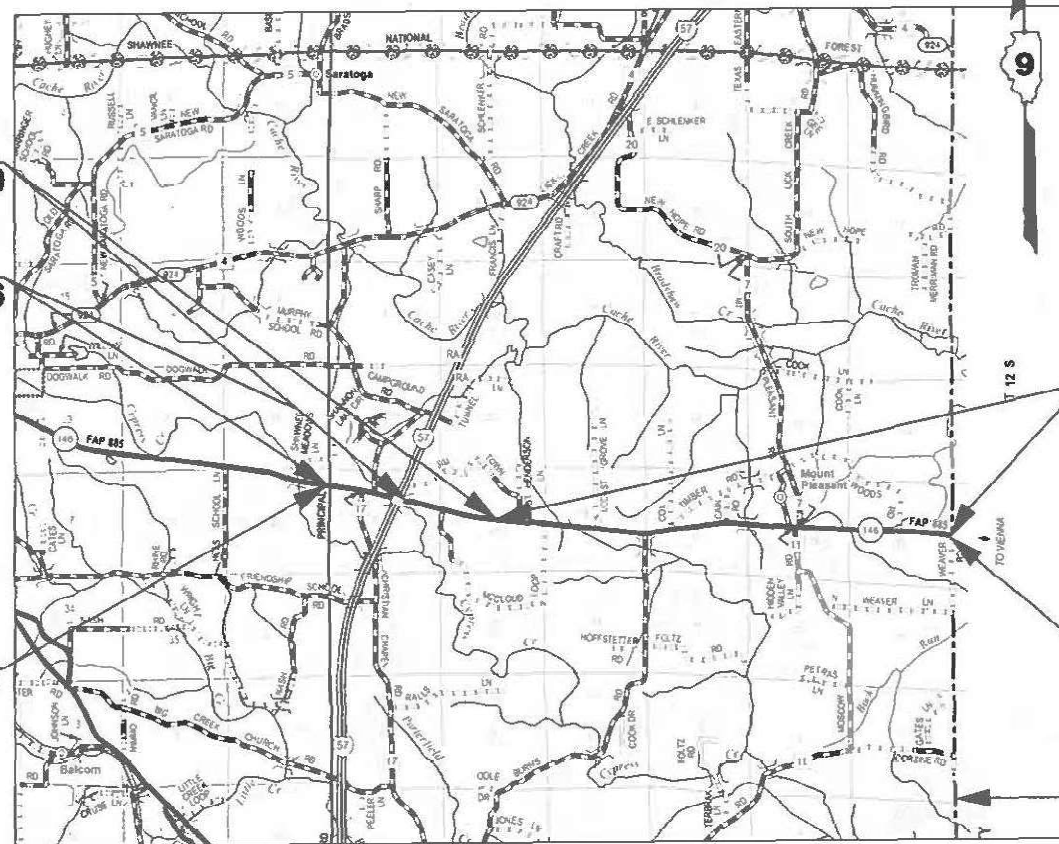

R1E

GROSS LENGTH = 31860.28 FT. = 6.03 MILE  
NET LENGTH = 31860.28 FT. = 6.03 MILE

PROJECT ENGINEER NATHAN TAYLOR  
PROJECT MANAGER NADIA MCMICHAEL

CONTRACT NO. 78A71

STATE OF ILLINOIS  
DEPARTMENT OF TRANSPORTATION

SUBMITTED August 12, 2024  
Kirk H. Brannon  
REGIONAL ENGINEER

October 4, 2024  
J. E. A. Elk  
ENGINEER OF DESIGN AND ENVIRONMENT

October 4, 2024  
Gemma J. Gu  
DIRECTOR OF HIGHWAYS PROJECT IMPLEMENTATION

**PRINTED BY THE AUTHORITY  
OF THE STATE OF ILLINOIS**

MODEL: 02-Signature [Sheet]  
 FILE NAME: G:\work\pmdt\illinois.gov\_nadia.mcmichael\illinois.gov\079866\090978A71-SMA-Cover\_Sig.dgn

Prepared By:   
 DISTRICT STUDIES & PLANS ENGINEER

Examined By:   
 DISTRICT LAND ACQUISITION ENGINEER

Examined By:   
 DISTRICT PROGRAM DEVELOPMENT ENGINEER

Examined By:   
 DISTRICT OPERATIONS ENGINEER

Examined By:   
 DISTRICT PROJECT IMPLEMENTATION ENGINEER

Examined By:   
 DISTRICT CONSTRUCTION ENGINEER

Examined By:   
 DISTRICT MATERIALS ENGINEER

USER NAME	▪ Nadia.McMichael	DESIGNED	-	REVISED	-
		DRAWN	-	REVISED	-
		CHECKED	-	REVISED	-
PLOT DATE	▪ 8/6/2024	DATE	-	REVISED	-

**STATE OF ILLINOIS  
 DEPARTMENT OF TRANSPORTATION**

**SIGNATURE SHEET**

SCALE	SHEET	2	OF	22	SHEETS	STA.	TO STA.
-------	-------	---	----	----	--------	------	---------

F.A.P. RTE.	SECTION	COUNTY	TOTAL SHEETS	SHEET NO.
885	106RS-6	UNION	22	2
ILLINOIS FED. AID PROJECT				

CONTRACT NO. 78A71

# GENERAL NOTES

- 1 FACTORS USED FOR ESTIMATING PLAN QUANTITIES ARE AS FOLLOWS AND SHALL NOT BE USED FOR THE BASIS OF FINAL QUANTITIES:
 

ALL HOT MIX ASPHALT	2.016 TONS/CU. YD.
ALL AGGREGATE	2.05 TONS/CU. YD.
- 2 THE ALGEBRAIC DIFFERENCE BETWEEN THE PAVEMENT AND SHOULDER SLOPES SHALL NOT EXCEED 10%. THE SHOULDER ON THE OUTSIDE OF SUPERELEVATED CURVES SHALL BE FLATTENED ACCORDINGLY.
- 3 THE QUANTITY OF SHORT TERM PAVEMENT MARKING SHOWN IN THE PLANS IS BASED ON ONE APPLICATION EACH FOR THE HMA SURFACE REMOVAL, BINDER COURSE, AND SURFACE COURSE
- 4 HMA RESURFACING SHALL BE PLACED IN A SEQUENCE THAT WILL MINIMIZE THE TIME THE CENTERLINE EDGE IS EXPOSED TO TRAFFIC. WHEN AT THE END OF A DAY'S OPERATION THE EXPOSED CENTERLINE EDGE IS GREATER THAN 2,000 FT, THE CONTRACTOR SHALL BE REQUIRED TO PAVE IN THE ADJACENT LANE ON THE FOLLOWING WORK DAY. PRIOR TO WINTER SHUTDOWN, RESURFACING ON ADJACENT LANES IS TO BE BROUGHT UP TO THE SAME ELEVATION.
- 5 LONGITUDINAL JOINT SEALANT SHALL BE PLACED UNDER THE HMA SURFACE COURSE
- 6 INCIDENTAL HOT-MIX ASPHALT SURFACING SHALL BE PAVED IN A SEPARATE OPERATION FROM THE MAINLINE PAVEMENT
- 7 COMMITMENTS: NONE

# INDEX OF SHEETS

SHEET NO	DESCRIPTION
1	COVER SHEET
2	SIGNATURE SHEET
3	INDEX OF SHEETS, HIGHWAY STANDARDS, GENERAL NOTES, & COMMITMENTS
4	MIX DESIGN & MTD RESTRICTIONS
5-6	SUMMARY OF QUANTITIES
7-9	TYPICAL SECTIONS: IL 146
10-20	SCHEDULE OF QUANTITIES
21-22	DETAIL SHEETS

# HIGHWAY STANDARDS

- 000001-08 STANDARD SYMBOLS, ABBREVIATIONS AND PATTERNS
- 001006 DECIMAL OF AN INCH AND OF A FOOT
- 406201-01 MAILBOX TURNOUT
- 420001-10 PAVEMENT JOINTS
- 442201-03 CLASS C & D PATCHES
- 482011-03 HMA SHOULDER, STRIPS\_SHOULDERS, WITH RESURFACING OR WIDENING & RESURFACING PROJECTS
- 701001-02 OFF-ROAD OPERATIONS, 2L, 2W, MORE THAN 15 FT AWAY
- 701006-05 OFF-ROAD OPERATIONS, 2L, 2W, 15 FT TO 24 IN FROM PAVEMENT EDGE
- 701011-04 OFF-ROAD MOVING OPERATIONS, 2L, 2W, DAY ONLY
- 701201-05 LANE CLOSURE, 2L, 2W, DAY ONLY, FOR SPEEDS 45 MPH OR MORE
- 701301-04 LANE CLOSURE, 2L, 2W, SHORT TIME OPERATIONS
- 701306-04 LANE CLOSURE, 2L, 2W, SLOW MOVING OPERATIONS DAY ONLY, FOR SPEEDS 45 MPH OR MORE
- 701311-03 LANE CLOSURE, 2L, 2W, MOVING OPERATIONS - DAY ONLY
- 701336-07 LANE CLOSURE, 2L, 2W, WORK AREAS IN SERIES, FOR SPEEDS 45MPH OR MORE
- 701901-09 TRAFFIC CONTROL DEVICES
- 780001-05 TYPICAL PAVEMENT MARKINGS
- 781001-04 TYPICAL APPLICATIONS RAISED REFLECTIVE PAVEMENT MARKERS

MODEL: Index (Sheet)  
 FILE NAME: c:\p\work\pav\illinois.gov\_nadia.mcMichael@illinois.gov\0978A71-SHB-Index\_CentNotes.dgn

	USER NAME = Nadia.McMichael	DESIGNED -	REVISED -	<b>STATE OF ILLINOIS DEPARTMENT OF TRANSPORTATION</b>	<b>INDEX OF SHEETS, HIGHWAY STANDARDS, GENERAL NOTES, &amp; COMMITMENTS</b>	F.A.P. RTE.	SECTION	COUNTY	TOTAL SHEETS	SHEET NO.	
		DRAWN -	REVISED -			885	106RS-6	UNION	22	3	
		CHECKED -	REVISED -			CONTRACT NO. 78A71					
	PLOT DATE = 8/5/2024	DATE -	REVISED -			SCALE:	SHEET 3 OF 22 SHEETS	STA.	TO STA.	ILLINOIS   FED. AID PROJECT	

# HMA MIXTURE REQUIREMENTS TABLES

The following HMA mixture requirements are applicable for this project

Locations	Hot-Mix Asphalt Surface Course
Mixture Use(s):	Hot-Mix Asphalt Surface Course, Mix D, N70
AB/PG:	PG64-22
Design Air Voids:	4.0%, 70 Gyration Design
Mixture Composition: (Gradation Mixture)	IL-9.5mm
Friction Aggregate:	Mix D
Mixture Weight:	112 LBS./SQ Yd/in
Quality Management Program:	PFP
Sublot Size:	1000
Material Transfer Device (Required?)	Yes

Locations	Hot-Mix Asphalt Binder Course
Mixture Use(s):	Hot-Mix Asphalt Binder Course, IL-9.5FG, N70
AB/PG:	PG64-22
Design Air Voids:	4.0%, 70 Gyration Design
Mixture Composition: (Gradation Mixture)	IL-9.5mm Fine Graded
Friction Aggregate:	None
Mixture Weight:	112 LBS./SQ Yd/in
Quality Management Program:	PFP
Sublot Size:	1000
Material Transfer Device (Required?)	Yes

Locations	Hot-Mix Shoulders
Mixture Use(s):	Hot-Mix Asphalt Surface Course, Mix C, N30
AB/PG:	PG64-22
Design Air Voids:	4.0%, 30 Gyration Design
Mixture Composition: (Gradation Mixture)	IL-9.5L
Friction Aggregate:	None
Mixture Weight:	112 LBS./SQ Yd/in
Quality Management Program:	QCQA
Sublot Size:	3000
Material Transfer Device (Required?)	No

# MTD CROSSING RESTRICTIONS TABLE

STRUCTURE NUMBER	EXISTING FILL HEIGHT OVER BOX CULVERT	THICKNESS OF EXISTING PAVEMENT OVER BOX CULVERT	MAXIMUM GROSS WEIGHT RESTRICTIONS	MTD CROSSING RESTRICTIONS APPLICABLE UNDER THE FOLLOWING CONDITION
(IL-146)	(FOOT)	(FOOT)	(TONS)	
SN 091-2008	NA	NA	40 TONS	EMPTY
SN 091-2013	NA	NA	40 TONS	EMPTY
SN 091-7050	NA	NA	40 TONS	EMPTY
SN 091-7051	NA	NA	40 TONS	EMPTY
SN 091-7052	NA	NA	38 TONS	EMPTY
SN 091-7053	NA	NA	40 TONS	EMPTY
SN 091-7054	NA	NA	40 TONS	EMPTY

MODEL: Mix Design and MTD Restrictions (Sheet)  
 FILE NAME: c:\p\work\pav\illinois.gov\_nadia.mcMichael\illinois.gov\0986609\0978A71-SHB-Index\_CenNotes.dgn

USER NAME = Nadia.McMichael	DESIGNED -	REVISED -
	DRAWN -	REVISED -
	CHECKED -	REVISED -
PLOT DATE = 8/5/2024	DATE -	REVISED -

**STATE OF ILLINOIS  
DEPARTMENT OF TRANSPORTATION**

**MIX DESIGN & MTD RESTRICTIONS**

SCALE: SHEET 4 OF 22 SHEETS STA. TO STA.

F.A.P RTE.	SECTION	COUNTY	TOTAL SHEETS	SHEET NO.
885	106RS-6	UNION	22	4
CONTRACT NO. 78A71				
ILLINOIS FED. AID PROJECT				

# SUMMARY OF QUANTITIES

COUNTY:	UNION CO	UNION CO	UNION CO
ROUTE:	FAP 885	FAP 885	FAP 885
FUNDING:	NHPP- 80% FED 20% STATE	STP - 80% FED 20% STATE	STP - 80% FED 20% STATE
LOCATION:	RURAL - LOCATION 1	RURAL - LOCATION 2	RURAL - LOCATION 3

CODE NUMBER	ITEM DESCRIPTION	UNIT	TOTAL QUANTITY	ROADWAY		
				0005	0005	0005
40600290	BITUMINOUS MATERIALS (TACK COAT)	POUND	61,997	9,891	7,894	44,212
40600370	LONGITUDINAL JOINT SEALANT	FOOT	31,864	3,122	4,179	24,563
40600990	TEMPORARY RAMP	SQ YD	896	296	153	447
40602970	HOT-MIX ASPHALT BINDER COURSE, IL-9.5FG, N70	TON	6,066	595	796	4,675
40604062	HOT-MIX ASPHALT SURFACE COURSE, IL-9.5, MIX "D", N70	TON	7,181	704	942	5,535
44000159	HOT-MIX ASPHALT SURFACE REMOVAL, 2 1/2"	SQ YD	91,848	14,653	11,695	65,500
44201385	CLASS C PATCHES, TYPE I, 13 INCH	SQ YD	44	6	8	30
44201389	CLASS C PATCHES, TYPE II, 13 INCH	SQ YD	2,813	436	508	1,869
44201394	CLASS C PATCHES, TYPE III, 13 INCH	SQ YD	194	36	84	74
44201396	CLASS C PATCHES, TYPE IV, 13 INCH	SQ YD	27	27		
48102100	AGGREGATE WEDGE SHOULDER, TYPE B	TON	545		75	470
48203100	HOT-MIX ASPHALT SHOULDERS	TON	1,060	975	85	
67000400	ENGINEER'S FIELD OFFICE, TYPE A	CAL MO	4	1	1	2

MODEL: Summary of Quantities (Sheet)  
FILE NAME: c:\p\work\project\illinois.gov\_nadia.mcMichael\illinois.gov\_nadia.mcMichael\1-ShtC-SoQ.dgn

USER NAME = Nadia.McMichael	DESIGNED -	REVISED -
	DRAWN -	REVISED -
	CHECKED -	REVISED -
PLOT DATE = 8/9/2024	DATE -	REVISED -

**STATE OF ILLINOIS  
DEPARTMENT OF TRANSPORTATION**

**SUMMARY OF QUANTITIES**

SCALE: SHEET 5 OF 22 SHEETS STA. TO STA.

F.A.P. RTE.	SECTION	COUNTY	TOTAL SHEETS	SHEET NO.
885	106RS-6	UNION	22	5
CONTRACT NO. 78A71				
ILLINOIS FED. AID PROJECT				

# SUMMARY OF QUANTITIES CONTD

COUNTY:	UNION CO	UNION CO	UNION CO
ROUTE:	FAP 885	FAP 885	FAP 885
FUNDING:	NHPP- 80% FED 20% STATE	STP - 80% FED 20% STATE	STP - 80% FED 20% STATE
LOCATION:	RURAL - LOCATION 1	RURAL - LOCATION 2	RURAL - LOCATION 3

CODE NUMBER	ITEM DESCRIPTION	UNIT	TOTAL QUANTITY	ROADWAY		
				0005	0005	0005
67100100	MOBILIZATION	L SUM	1	0.25	0.25	0.5
70100450	TRAFFIC CONTROL AND PROTECTION, STANDARD 701201	L SUM	1	0.25	0.25	0.5
70100460	TRAFFIC CONTROL AND PROTECTION, STANDARD 701306	L SUM	1	0.25	0.25	0.5
70100600	TRAFFIC CONTROL AND PROTECTION, STANDARD 701336	L SUM	1	0.25	0.25	0.5
70107025	CHANGEABLE MESSAGE SIGN	CAL DA	28	7	7	14
70300100	SHORT TERM PAVEMENT MARKING	FOOT	8,705	854	1,141	6,710
70300150	SHORT TERM PAVEMENT MARKING REMOVAL	SQ FT	2,911	285	381	2,245
70300221	TEMPORARY PAVEMENT MARKING - LINE 4" - PAINT	FOOT	103,614	7,221	9,429	86,964
* 78001110	PAINT PAVEMENT MARKING - LINE 4"	FOOT	103,614	7,221	9,429	86,964
* 78100100	RAISED REFLECTIVE PAVEMENT MARKER	EACH	411	40	53	318
78300200	RAISED REFLECTIVE PAVEMENT MARKER REMOVAL	EACH	411	40	53	318
78300201	PAVEMENT MARKING REMOVAL - GRINDING	SQ FT	34,549	2,408	3,144	28,997
Z0034105	MATERIAL TRANSFER DEVICE	TON	13,247	1,299	1,738	10,210

\* SPECIALTY ITEM

MODEL: Summary of Quantities Contd-1 [Sheet]  
FILE NAME: c:\p\work\project\illinois.gov\_nadia.mcMichael\illinois.gov\_nadia.mcMichael.dgn

USER NAME = Nadia.McMichael	DESIGNED -	REVISED -
	DRAWN -	REVISED -
	CHECKED -	REVISED -
PLOT DATE = 8/9/2024	DATE -	REVISED -

STATE OF ILLINOIS  
DEPARTMENT OF TRANSPORTATION

SUMMARY OF QUANTITIES

SCALE: SHEET 6 OF 22 SHEETS STA. TO STA.

F.A.P. RTE.	SECTION	COUNTY	TOTAL SHEETS	SHEET NO.
885	106RS-6	UNION	22	6
CONTRACT NO. 78A71				
ILLINOIS FED. AID PROJECT				

**STATION EQUATIONS**

STA 247+91.25 BK = 248+00.42 AH

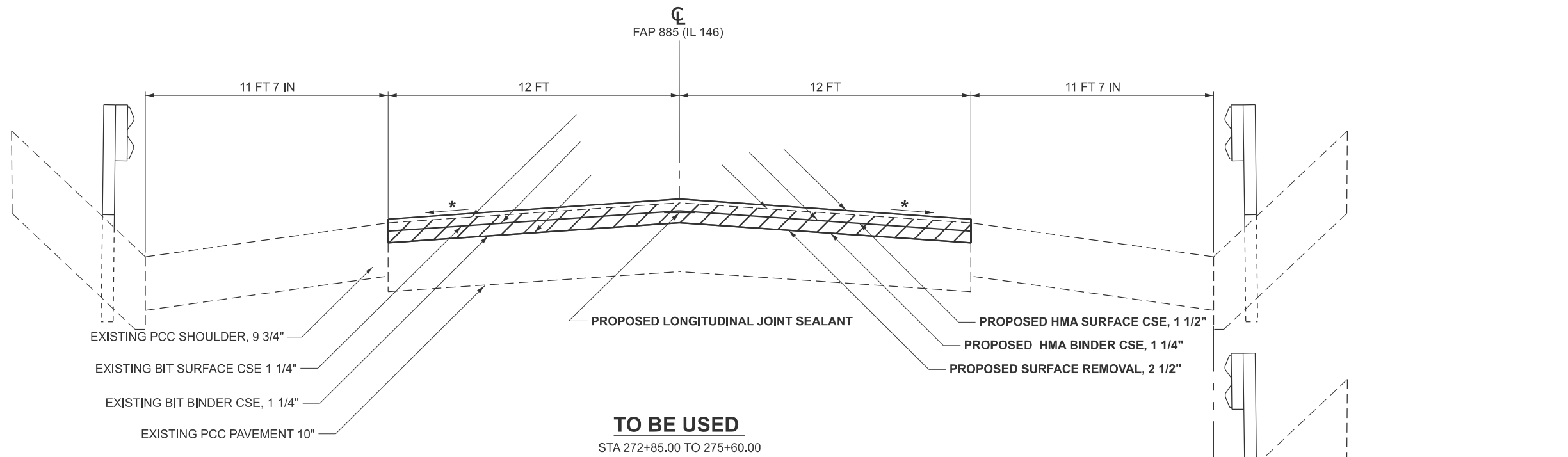
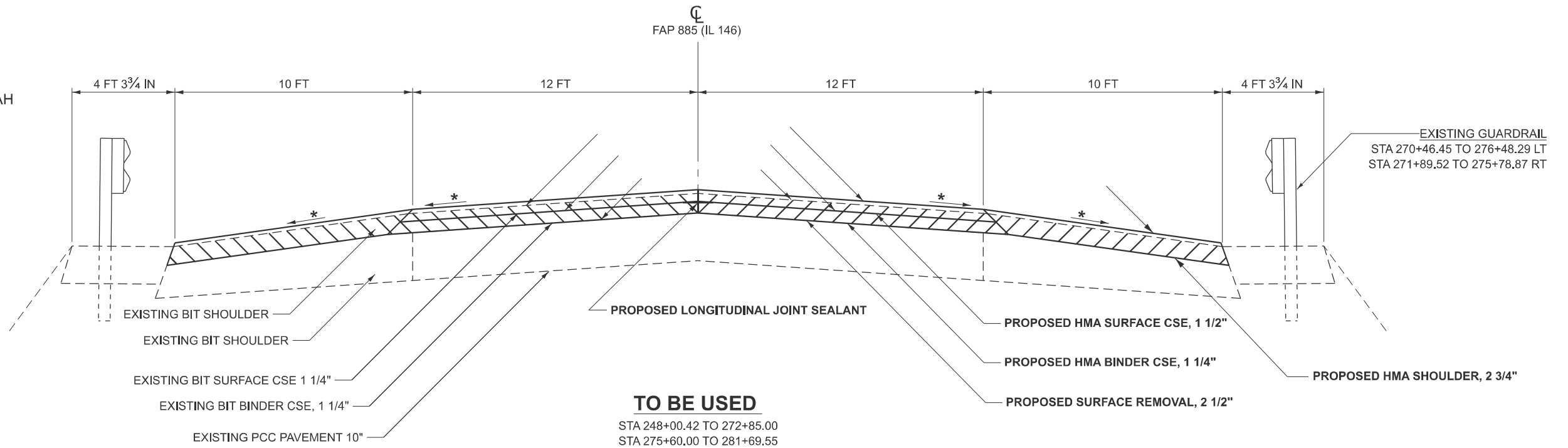

\* = MATCH EXISTING

- TYPICAL SECTIONS ARE NOT DRAWN TO SCALE
- LONGITUDINAL JOINT SEALANT IS TO BE PLACED BETWEEN BINDER AND SURFACE COURSE

EXISTING CONCRETE CURB  
STA 273+37.68 TO 275+09.56 LT  
STA 273+28.22 TO 275+00.14 RT

MODEL: Typical-2 (Sheet)  
FILE NAME: c:\p\work\pav\illinois.gov\_nadia.mcMichael\illinois.gov\_nadia.mcMichael\0978A71-SHD-Typicals.dgn

USER NAME = Nadia.McMichael	DESIGNED -	REVISED -
	DRAWN -	REVISED -
	CHECKED -	REVISED -
PLOT DATE = 8/7/2024	DATE -	REVISED -

**STATE OF ILLINOIS  
DEPARTMENT OF TRANSPORTATION**

**TYPICAL SECTIONS  
IL 146**

SCALE: SHEET 7 OF 22 SHEETS STA. TO STA.

F.A.P. RTE.	SECTION	COUNTY	TOTAL SHEETS	SHEET NO.
885	106RS-6	UNION	22	7
CONTRACT NO. 78A71				
ILLINOIS FED. AID PROJECT				

**STATION EQUATIONS**

STA 566+60.70 BK = 566+74.00 AH

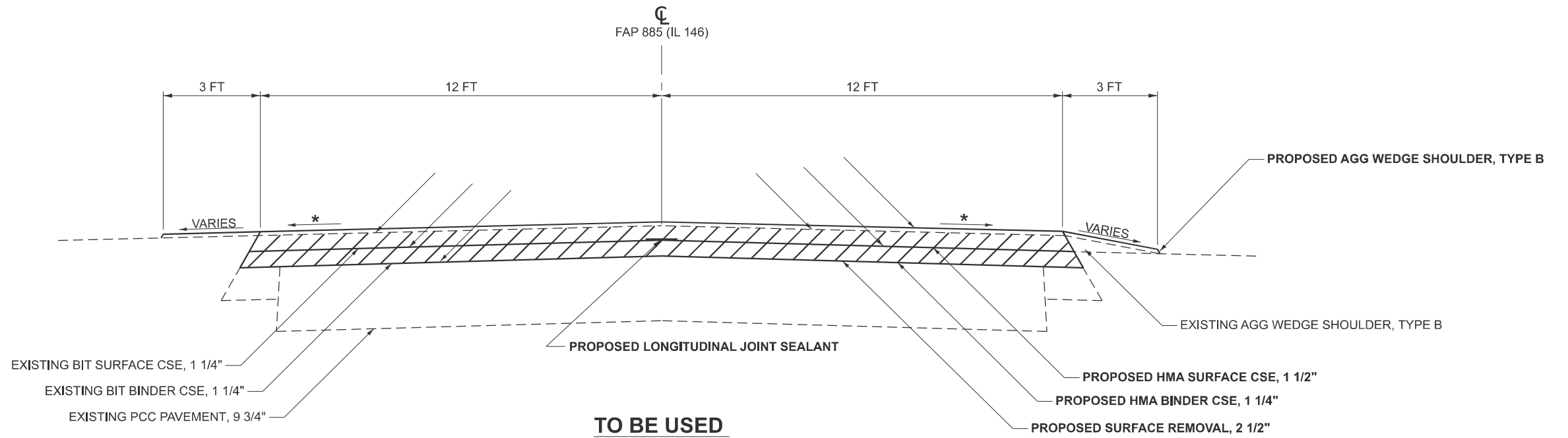

**TO BE USED**  
STA 281+69.55 TO 321+00.00

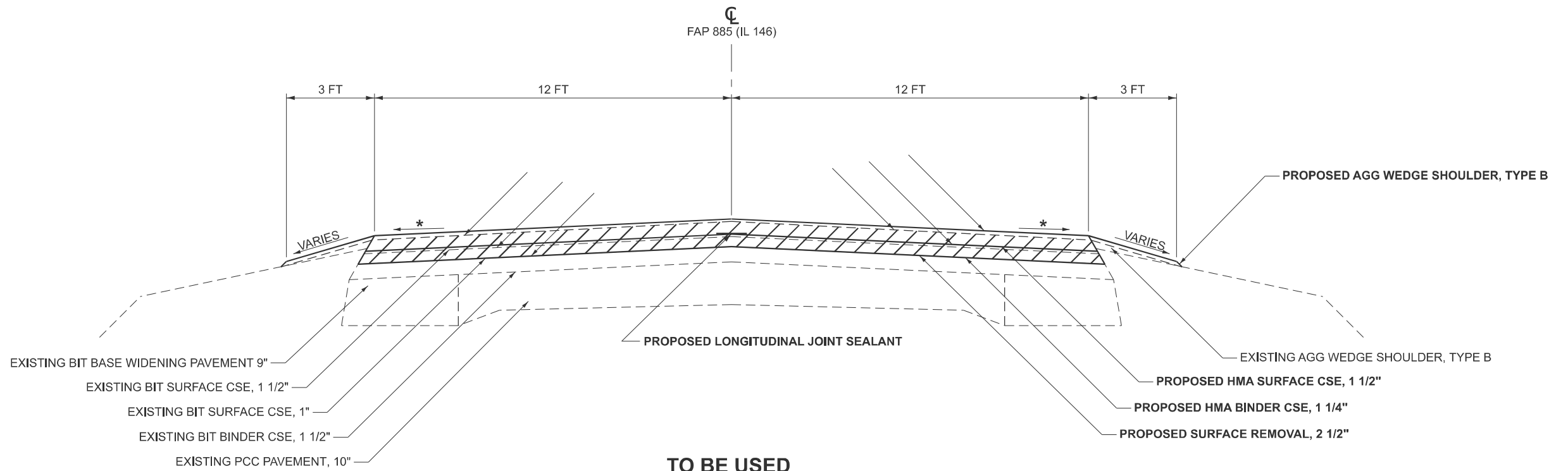

**TO BE USED**  
STA 321+00.00 TO 401+75.40  
STA 412+84.30 TO 443+04.30  
STA 453+44.30 TO 477+43.20  
STA 487+76.50 TO 566+60.70

\* = MATCH EXISTING

- TYPICAL SECTIONS ARE NOT DRAWN TO SCALE

- LONGITUDINAL JOINT SEALANT IS TO BE PLACED BETWEEN BINDER AND SURFACE COURSE

MODEL: Typical-5 (Sheet)  
FILE NAME: c:\p\work\pav\illinois.gov\_nadia.mcMichael@illinois.gov\d0986609\0978A71-SHD-Typicals.dgn

USER NAME = Nadia.McMichael	DESIGNED -	REVISED -
	DRAWN -	REVISED -
	CHECKED -	REVISED -
PLOT DATE = 8/5/2024	DATE -	REVISED -

**STATE OF ILLINOIS  
DEPARTMENT OF TRANSPORTATION**

**TYPICAL SECTIONS  
IL 146**

SCALE: SHEET 8 OF 22 SHEETS STA. TO STA.

F.A.P. RTE.	SECTION	COUNTY	TOTAL SHEETS	SHEET NO.
885	106RS-6	UNION	22	8
CONTRACT NO. 78A71				
ILLINOIS FED. AID PROJECT				



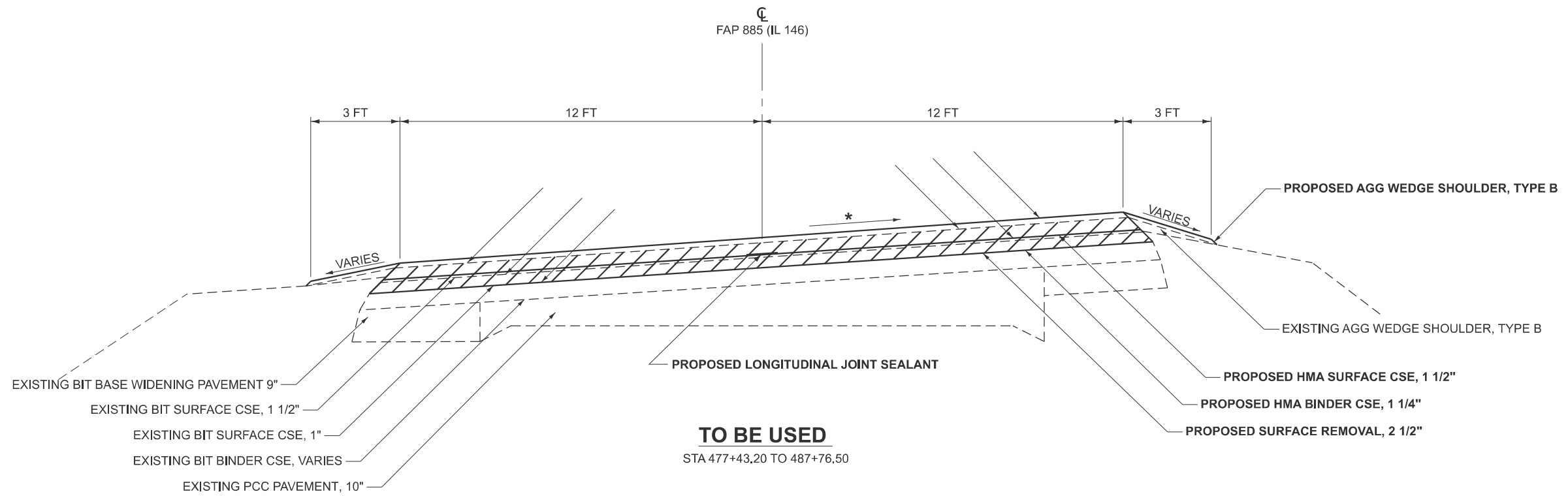
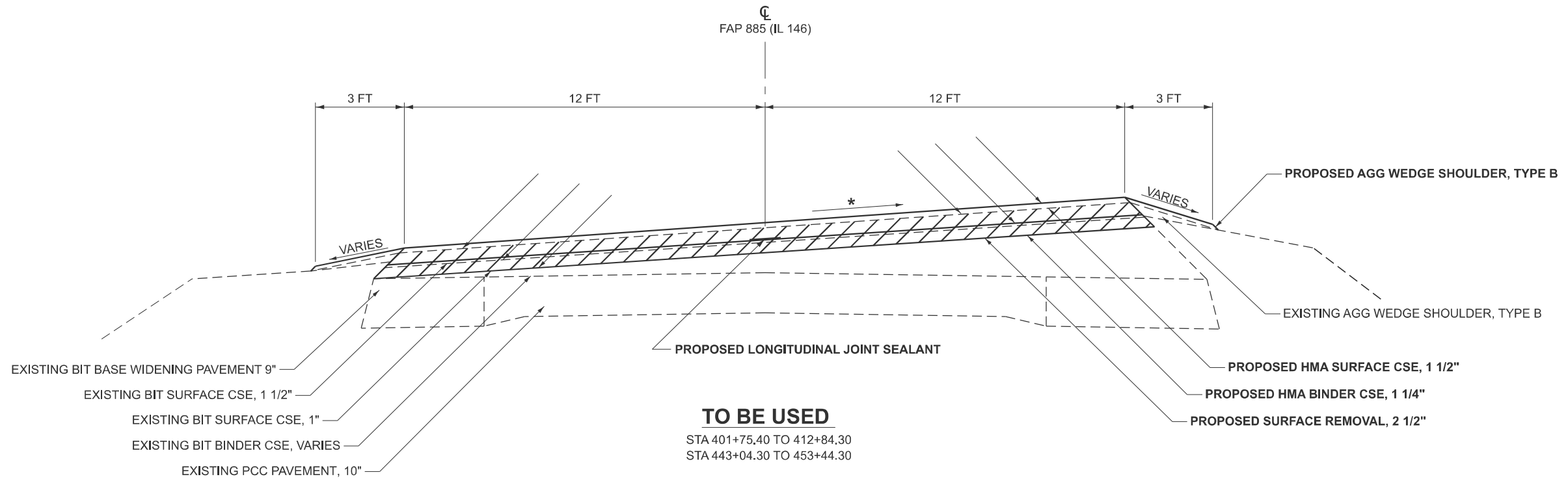

- \* = MATCH EXISTING
- TYPICAL SECTIONS ARE NOT DRAWN TO SCALE
  - LONGITUDINAL JOINT SEALANT IS TO BE PLACED BETWEEN BINDER AND SURFACE COURSE

MODEL: Typical-4 (Sheet)  
 FILE NAME: c:\p\work\pav\illinois.gov\_nadia.mcMichael@illinois.gov\0978A71-SHD-Typical.dgn

USER NAME = Nadia.McMichael	DESIGNED -	REVISED -
	DRAWN -	REVISED -
	CHECKED -	REVISED -
PLOT DATE = 8/7/2024	DATE -	REVISED -

**STATE OF ILLINOIS**  
**DEPARTMENT OF TRANSPORTATION**

**TYPICAL SECTIONS**  
**IL 146**

SCALE: SHEET 9 OF 22 SHEETS STA. TO STA.

F.A.P. RTE.	SECTION	COUNTY	TOTAL SHEETS	SHEET NO.
885	106RS-6	UNION	22	9
CONTRACT NO. 78A71				
ILLINOIS FED. AID PROJECT				

# HMA PAVEMENT SCHEDULE

LOCATION STATION TO STATION	PAVEMENT LENGTH	PAVEMENT WIDTH	TEMPORARY RAMPS	HMA SURFACE REMOVAL, (2 1/2")	HMA BINDER CSE IL-9.5FG, N70, (1 1/4")	HMA SURFACE CSE MIX "D", N70, (1 1/2")	MATERIAL TRANSFER DEVICE	LONGITUDINAL JOINT SEALANT	BITUMINOUS MATERIALS (TACK COAT)	
	FOR INFORMATIONAL USE ONLY			(SQ YD)	(SQ YD)	(TON)	(TON)	(TON)	(FOOT)	(LB)
	(FOOT)	(FOOT)		(SQ YD)	(SQ YD)	(TON)	(TON)	(TON)	(FOOT)	(LB)
<b>IL 146 UNION COUNTY</b>										
248+00.42 TO 272+85.00	2485	24	25	6626	473	560	1033	2485	4473	
272+85.00 TO 275+60.00	275	24		734	53	62	115	275	495	
275+60.00 TO 279+21.76	362	24		965	69	82	151	362	652	
<b>SUBTOTAL FOR LOCATION 1</b>			<b>25</b>	<b>8325</b>	<b>595</b>	<b>704</b>	<b>1299</b>	<b>3122</b>	<b>5620</b>	
279+21.76 TO 281+69.55	248	24		661	48	56	104	248	447	
281+69.55 TO 321+00.00	3930	24		10482	748	886	1634	3931	7075	
<b>SUBTOTAL FOR LOCATION 2</b>				<b>11143</b>	<b>796</b>	<b>942</b>	<b>1738</b>	<b>4179</b>	<b>7522</b>	
321+00.00 TO 401+75.40	8075	24		21535	1537	1819	3356	8076	14536	
401+75.40 TO 412+84.30	1109	24		2958	211	250	461	1109	1997	
412+84.30 TO 443+04.30	3020	24		8054	575	681	1256	3020	5436	
443+04.30 TO 453+44.30	1040	24		2774	198	235	433	1040	1872	
453+44.30 TO 477+43.20	2399	24		6398	457	541	998	2399	4319	
477+43.20 TO 487+76.50	1033	24		2756	197	233	430	1034	1860	
487+76.50 TO 566+60.70	7884	24	25	21025	1500	1776	3276	7885	14192	
<b>SUBTOTAL FOR LOCATION 3</b>			<b>25</b>	<b>65500</b>	<b>4675</b>	<b>5535</b>	<b>10210</b>	<b>24563</b>	<b>44212</b>	
<b>PROJECT TOTAL</b>			<b>50</b>	<b>84968</b>	<b>6066</b>	<b>7181</b>	<b>13247</b>	<b>31864</b>	<b>57354</b>	

MODEL: HMA Pavement Schedule (Sheet)  
 FILE NAME: c:\p\work\pav\illinois.gov\_nadia.mcMichael@illinois.gov\0986609\0978A71-SHE-Schedules.dgn

USER NAME = Nadia.McMichael	DESIGNED -	REVISED -
	DRAWN -	REVISED -
	CHECKED -	REVISED -
PLOT DATE = 8/8/2024	DATE -	REVISED -

**STATE OF ILLINOIS  
DEPARTMENT OF TRANSPORTATION**

**HMA PAVEMENT SCHEDULE**

SCALE: SHEET 10 OF 22 SHEETS STA. TO STA.

F.A.P RTE.	SECTION	COUNTY	TOTAL SHEETS	SHEET NO.
885	106RS-6	UNION	22	10
CONTRACT NO. 78A71				
ILLINOIS FED. AID PROJECT				

# SHOULDER SCHEDULE

LOCATION STATION TO STATION	PAVEMENT LENGTH	HMA SHOULDER WIDTH	AGG SHOULDER WIDTH	HMA SURFACE REMOVAL, (2 1/2")	HMA SHOULDERS (2 3/4")	AGG WEDGE SHOULDER, TYPE B	BITUMINOUS MATERIALS (TACK COAT)
	FOR INFORMATIONAL USE ONLY						
	(FOOT)	(FOOT)	(FOOT)	(SQ YD)	(TON)	(TON)	(LB)
<b>IL 146 UNION COUNTY</b>							
248+00.42 TO 272+85.00	2485	10		5523	851		3728
275+60.00 TO 279+21.76	362	10		805	124		543
<b>SUBTOTAL FOR LOCATION 1</b>				<b>6328</b>	<b>975</b>		<b>4271</b>
279+21.76 TO 281+69.55	248	10		552	85		372
281+69.55 TO 321+00.00	3931		3			75	
<b>SUBTOTAL FOR LOCATION 2</b>				<b>552</b>	<b>85</b>	<b>75</b>	<b>372</b>
321+00.00 TO 401+75.40	8076		3			154	
401+75.40 TO 412+84.30	1109		3			22	
412+84.30 TO 443+04.30	3020		3			58	
443+04.30 TO 453+44.30	1040		3			20	
453+44.30 TO 477+43.20	2399		3			46	
477+43.20 TO 487+76.50	1034		3			20	
487+76.50 TO 566+60.70	7885		3			150	
<b>SUBTOTAL FOR LOCATION 3</b>						<b>470</b>	
<b>PROJECT TOTAL</b>				<b>6880</b>	<b>1060</b>	<b>545</b>	<b>4643</b>

\* STA 272+85.00 TO 275+60.00 IS OMITTED FROM SHOULDER WORK. EXISTING PCC SHOULDERS WILL REMAIN

MODEL: Shoulder Schedule-1 [Sheet]  
FILE NAME: c:\p\work\pav\illinois.gov\_nadia.mcMichael@illinois.gov\106RS-6\11-SHE-Schedules.dgn

USER NAME = Nadia.McMichael	DESIGNED -	REVISED -
	DRAWN -	REVISED -
	CHECKED -	REVISED -
PLOT DATE = 8/8/2024	DATE -	REVISED -

**STATE OF ILLINOIS  
DEPARTMENT OF TRANSPORTATION**

**SHOULDER SCHEDULE**

SCALE: SHEET 11 OF 22 SHEETS STA. TO STA.

F.A.P RTE.	SECTION	COUNTY	TOTAL SHEETS	SHEET NO.
885	106RS-6	UNION	22	11
CONTRACT NO. 78A71				
ILLINOIS FED. AID PROJECT				

# ENTRANCE & SIDE ROAD SCHEDULE

STATION	ROAD NAME OR DESCRIPTION	LOCATION LT/RT	ENTRANCE TYPE	EXISTING SURFACE	EDGE OF PAVEMENT WIDTH	PAVEMENT LENGTH	END OF TAPER WIDTH	TEMPORARY RAMPS	
				FOR INFORMATIONAL USE ONLY					
				(FOOT)	(FOOT)	(FOOT)	(FOOT)		(SQ YD)
<b>IL 146 UNION COUNTY</b>									
		RT	PE	HMA	35	4	18	14	
		LT	CE	PCC	40	4	38	16	
	CHRISTIAN CHAPEL	RT	SR	PCC	89	39	23	35	
		LT	CE	HMA	40	4	38	16	
	CAMPGROUND ROAD	LT	SR	HMA	46	26	16	18	
	CASEY WAY	RT	SR	HMA	69	26	30	27	
	CASEY WAY	RT	CE	PCC	40	4	38	16	
		LT	CE	PCC	40	4	38	16	
	SB RAMP EXIT	LT	SR	PCC	69	59	16	27	
	SB RAMP ENTRANCE	RT	SR	PCC	69	59	16	27	
	NB RAMP ENTRANCE	LT	SR	HMA	69	59	16	27	
	NB RAMP EXIT	RT	SR	HMA	69	59	16	32	
<b>SUBTOTAL FOR LOCATION 1</b>								<b>271</b>	
	JIMTOWN LOOP	LT	SR	HMA	82	26	26	32	
	MCCLLOUD LOOP	RT	SR	HMA	79	23	23	31	
		RT	SR	HMA	65	15	45	26	
		RT	SR	HMA	65	15	45	26	
		RT	PE	HMA	42	7	25	17	
		RT	PE	HMA	32	4	18	13	
		RT	PE	HMA	20	4	18	8	
<b>SUBTOTAL FOR LOCATION 2</b>								<b>153</b>	
339 + 21	JIM TOWN LOOP	LT	SR	HMA	61	15	32	24	
351 + 72	MCCLLOUD LOOP	RT	SR	HMA	68	15	45	27	
380+10	LOCUST GROVE LN	LT	SR	HMA	68	15	30	27	
		RT	PE	HMA	30	4	20	12	
405 + 64		LT	PE	HMA	30	8	18	12	
405 + 64	BURNS ROAD	RT	SR	HMA	133	15	47	52	
		LT	CE	HMA	30	4	38	12	
		LT	CE	HMA	25	4	38	10	
		LT	PE	HMA	35	6	18	14	
419+27	TIMBER ROAD	LT	SR	HMA	68	15	29	27	
		RT	PE	HMA	30	4	18	12	
448 + 58	CAIN ROAD	LT	SR	HMA	70	15	25	28	
		RT	PE	HMA	35	4	25	14	
		LT	PE	HMA	30	4	18	12	
481 + 56	OLD MT PLEASANT ROAD	LT	SR	HMA	74	15	35	29	
484 + 17	MOSCOW ROAD	RT	SR	HMA	85	15	42	34	
487 + 04	MT PLEASANT ROAD	LT	SR	HMA	80	15	38	32	
	HAWK HILL LANE	RT	PE	HMA	45	4	20	18	
539 + 50	WOODS ROAD	LT	SR	HMA	65	15	23	26	
<b>SUBTOTAL FOR LOCATION 3</b>								<b>422</b>	
<b>PROJECT TOTAL</b>								<b>846</b>	

MODEL: Entrance and Side Road Schedule (Sheet)  
FILE NAME: c:\p\work\view\illinois.gov\_nadia.mcMichael@illinois.gov\0986609\0978A71-SHE-Schedules.dgn

USER NAME = Nadia.McMichael	DESIGNED -	REVISED -
	DRAWN -	REVISED -
	CHECKED -	REVISED -
PLOT DATE = 8/8/2024	DATE -	REVISED -

**STATE OF ILLINOIS  
DEPARTMENT OF TRANSPORTATION**

**ENTRANCE AND SIDE ROAD  
SCHEDULE**

SCALE: SHEET 12 OF 22 SHEETS STA. TO STA.

F.A.P. RTE.	SECTION	COUNTY	TOTAL SHEETS	SHEET NO.
885	106RS-6	UNION	22	12
CONTRACT NO. 78A71				
ILLINOIS FED. AID PROJECT				

## EASTBOUND PATCHING SCHEDULE

LANE	DISTANCE FROM PROJECT START	LENGTH	WIDTH	AREA	CLASS C PATCHES, TYPE I, 13 INCH	CLASS C PATCHES, TYPE II, 13 INCH	CLASS C PATCHES, TYPE III, 13 INCH	CLASS C PATCHES, TYPE IV, 13 INCH
	(MILES)	(FOOT)	(FOOT)	(SQ YD)	(SQ YD)	(SQ YD)	(SQ YD)	(SQ YD)
<b>IL 146 UNION COUNTY</b>								
EB	0	5	12	7		7		
EB		4	12	6		6		
EB		4	12	6		6		
EB		4	12	6		6		
EB	0.1	20	6	14		14		
EB		4	12	6		6		
EB		6	12	8		8		
EB		5	12	7		7		
EB		8	12	11		11		
EB		4	12	6		6		
EB		8	12	11		11		
EB	0.2	6	4	3	3			
EB		4	12	6		6		
EB		15	12	20			20	
EB		4	12	6		6		
EB	0.3	4	12	6		6		
EB		12	6	8		8		
EB		4	12	6		6		
EB		4	12	6		6		
EB		4	12	6		6		
EB		8	12	11		11		
EB		6	12	8		8		
EB	0.4	6	12	8		8		
EB		4	12	6		6		
EB		6	12	8		8		
EB		4	12	6		6		
EB	0.5	6	12	8		8		
EB		6	12	8		8		
<b>EASTBOUND SUBTOTAL FOR LOCATION 1</b>					<b>3</b>	<b>195</b>	<b>20</b>	
EB		10	12	14		14		
EB		6	12	8		8		
EB		8	12	11		11		
EB	0.7	6	12	8		8		
EB		8	12	11		11		
EB		6	12	8		8		
EB		8	4	4	4			
EB		5	12	7		7		
EB		4	12	6		6		
EB		5	12	7		7		
EB	0.8	6	12	8		8		
EB		10	12	14		14		

## EASTBOUND PATCHING SCHEDULE CONTD

LANE	DISTANCE FROM PROJECT START	LENGTH	WIDTH	AREA	CLASS C PATCHES, TYPE I, 13 INCH	CLASS C PATCHES, TYPE II, 13 INCH	CLASS C PATCHES, TYPE III, 13 INCH	CLASS C PATCHES, TYPE IV, 13 INCH
	(MILES)	(FOOT)	(FOOT)	(SQ YD)	(SQ YD)	(SQ YD)	(SQ YD)	(SQ YD)
<b>IL 146 UNION COUNTY</b>								
EB		12	12	16			16	
EB	0.9	12	12	16			16	
EB		6	12	8		8		
EB		8	12	11		11		
EB		4	12	6		6		
EB		7	12	10		10		
EB		15	12	20			20	
EB		4	12	6		6		
EB		6	12	8		8		
EB	1	6	12	8		8		
EB		6	12	8		8		
EB		6	12	8		8		
EB		6	12	8		8		
EB	1.1	4	12	6		6		
EB		4	12	6		6		
EB		4	12	6		6		
EB	1.2	4	12	6		6		
EB		6	12	8		8		
EB		6	12	8		8		
EB		4	12	6		6		
EB		8	12	11		11		
EB	1.3	4	12	6		6		
EB		6	12	8		8		
EB		4	12	6		6		
EB		4	12	6		6		
<b>EASTBOUND SUBTOTAL FOR LOCATION 2</b>					<b>4</b>	<b>266</b>	<b>52</b>	
EB	1.4	6	12	8		8		
EB		6	12	8		8		
EB	1.5	4	12	6		6		
EB		10	12	14		14		
EB		6	12	8		8		
EB	1.6	4	12	6		6		
EB		4	12	6		6		
EB		6	12	8		8		
EB		4	12	6		6		
EB	1.7	8	12	11		11		
EB		4	12	6		6		
EB		4	12	6		6		
EB		10	6	7		7		
EB		16	12	22			22	
EB		4	12	6		6		

MODEL: Patching Schedule-1 (Sheet)  
 FILE NAME: c:\pa\_work\pwr\illinois.gov\_nadia.mcMichael@illinois.gov\_0986609D978A71-SHE-Schedules.dgn

USER NAME = Nadia.McMichael	DESIGNED -	REVISED -
	DRAWN -	REVISED -
	CHECKED -	REVISED -
PLOT DATE = 8/8/2024	DATE -	REVISED -

**STATE OF ILLINOIS  
DEPARTMENT OF TRANSPORTATION**

**PATCHING SCHEDULES**

SCALE: SHEET 13 OF 22 SHEETS STA. TO STA.

F.A.P. RTE.	SECTION	COUNTY	TOTAL SHEETS	SHEET NO.
885	106RS-6	UNION	22	13
CONTRACT NO. 78A71				
ILLINOIS FED. AID PROJECT				

## EASTBOUND PATCHING SCHEDULE CONTD

LANE	DISTANCE FROM PROJECT START	LENGTH	WIDTH	AREA	CLASS C PATCHES, TYPE I, 13 INCH	CLASS C PATCHES, TYPE II, 13 INCH	CLASS C PATCHES, TYPE III, 13 INCH	CLASS C PATCHES, TYPE IV, 13 INCH
	(MILES)	(FOOT)	(FOOT)	(SQ YD)	(SQ YD)	(SQ YD)	(SQ YD)	(SQ YD)
<b>IL 146 UNION COUNTY</b>								
EB	1.8	4	12	6		6		
EB		8	12	11		11		
EB		8	12	11		11		
EB	1.9	8	12	11		11		
EB	2	4	12	6		6		
EB		6	12	8		8		
EB		4	12	6		6		
EB		6	12	8		8		
EB		6	12	8		8		
EB		6	12	8		8		
EB		12	12	16			16	
EB		20	6	14		14		
EB	2.1	6	12	8		8		
EB	2.2	4	12	6		6		
EB		6	12	8		8		
EB		4	12	6		6		
EB		6	12	8		8		
EB		6	12	8		8		
EB	2.4	6	12	8		8		
EB		7	12	10		10		
EB		5	12	7		7		
EB		5	12	7		7		
EB	2.6	4	12	6		6		
EB		6	12	8		8		
EB		4	12	6		6		
EB		5	12	7		7		
EB		6	12	8		8		
EB		4	12	6		6		
EB		4	12	6		6		
EB		6	12	8		8		
EB		4	12	6		6		
EB	2.8	4	12	6		6		
EB		7	12	10		10		
EB		5	12	7		7		
EB		6	12	8		8		
EB	3	5	12	7		7		
EB		6	12	8		8		
EB		6	12	8		8		
EB	3.1	5	12	7		7		
EB		6	12	8		8		
EB		10	6	7		7		
EB	3.2	6	4	3	3			
EB		6	12	8		8		
EB	3.3	6	12	8		8		

## EASTBOUND PATCHING SCHEDULE CONTD

LANE	DISTANCE FROM PROJECT START	LENGTH	WIDTH	AREA	CLASS C PATCHES, TYPE I, 13 INCH	CLASS C PATCHES, TYPE II, 13 INCH	CLASS C PATCHES, TYPE III, 13 INCH	CLASS C PATCHES, TYPE IV, 13 INCH
	(MILES)	(FOOT)	(FOOT)	(SQ YD)	(SQ YD)	(SQ YD)	(SQ YD)	(SQ YD)
<b>IL 146 UNION COUNTY</b>								
EB	3.4	6	12	8		8		
EB		6	12	8		8		
EB	3.5	4	12	6		6		
EB		6	12	8		8		
EB		4	12	6		6		
EB		6	12	8		8		
EB		4	12	6		6		
EB	3.6	5	12	7		7		
EB		6	12	8		8		
EB	3.7	6	12	8		8		
EB		8	12	11		11		
EB	3.8	6	12	8		8		
EB		4	12	6		6		
EB	3.9	7	12	10		10		
EB		6	12	8		8		
EB	4	12	12	16			16	
EB	4.1	5	12	7		7		
EB	4.2	5	12	7		7		
EB		10	12	14		14		
EB		12	4	6		6		
EB	4.3	8	12	11		11		
EB	4.4	6	12	8		8		
EB		4	12	6		6		
EB		4	12	6		6		
EB	4.5	4	12	6		6		
EB		6	12	8		8		
EB	4.6	6	12	8		8		
EB		8.0	12.0	11		11		
EB		4.0	12.0	6		6		
EB		4.0	12.0	6		6		
EB		4.0	12.0	6		6		
EB		4.0	12.0	6		6		
EB	4.7	4.0	12.0	6		6		
EB	4.8	6.0	12.0	8		8		
EB	4.9	4.0	12.0	6		6		
EB		4.0	12.0	6		6		
EB	5	4.0	12.0	6		6		
EB		4.0	12.0	6		6		
EB	5.1	6.0	12.0	8		8		
EB	5.2	4.0	12.0	6		6		
EB		4.0	12.0	6		6		

MODEL: Patching Schedule (Sheet)  
 FILE NAME: c:\pa\_work\pwr\illinois.gov\_nadia.mcMichael@illinois.gov\0986609\0978A71-SHE-Schedules.dgn

USER NAME = Nadia.McMichael	DESIGNED -	REVISED -
	DRAWN -	REVISED -
	CHECKED -	REVISED -
PLOT DATE = 8/8/2024	DATE -	REVISED -

**STATE OF ILLINOIS  
DEPARTMENT OF TRANSPORTATION**

**PATCHING SCHEDULES**

SCALE: SHEET 14 OF 22 SHEETS STA. TO STA.

F.A.P. RTE.	SECTION	COUNTY	TOTAL SHEETS	SHEET NO.
885	106RS-6	UNION	22	14
CONTRACT NO. 78A71				
ILLINOIS FED. AID PROJECT				

## EASTBOUND PATCHING SCHEDULE CONTD

LANE	DISTANCE FROM PROJECT START	LENGTH	WIDTH	AREA	CLASS C PATCHES, TYPE I, 13 INCH	CLASS C PATCHES, TYPE II, 13 INCH	CLASS C PATCHES, TYPE III, 13 INCH	CLASS C PATCHES, TYPE IV, 13 INCH
	(MILES)	(FOOT)	(FOOT)	(SQ YD)	(SQ YD)	(SQ YD)	(SQ YD)	(SQ YD)
<b>IL 146 UNION COUNTY</b>								
EB		4.0	12.0	6		6		
EB	5.3	4.0	12.0	6		6		
EB		8.0	12.0	11		11		
EB		4.0	12.0	6		6		
EB		4.0	12.0	6		6		
EB		4.0	12.0	6		6		
EB		4.0	12.0	6		6		
EB		6.0	12.0	8		8		
EB		5.0	12.0	7		7		
EB	5.4	4.0	12.0	6		6		
EB	5.6	6.0	12.0	8		8		
EB		4.0	12.0	6		6		
EB		8.0	6.0	6		6		
EB		4.0	12.0	6		6		
EB	5.7	12.0	4.0	6		6		
EB		7.0	12.0	10		10		
EB		4.0	12.0	6		6		
EB	5.8	4.0	4.0	2	2			
EB	5.9	4.0	12.0	6		6		
EB		4.0	12.0	6		6		
EB		4.0	12.0	6		6		
EB		4.0	12.0	6		6		
EB		8.0	12.0	11		11		
EB		4.0	12.0	6		6		
EB	6	4.0	12.0	6		6		
<b>EASTBOUND SUBTOTAL FOR LOCATION 3</b>					<b>5</b>	<b>871</b>	<b>54</b>	
<b>EASTBOUND TOTAL</b>					<b>12</b>	<b>1332</b>	<b>126</b>	

## WESTBOUND PATCHING SCHEDULE

LANE	DISTANCE FROM PROJECT START	LENGTH	WIDTH	AREA	CLASS C PATCHES, TYPE I, 13 INCH	CLASS C PATCHES, TYPE II, 13 INCH	CLASS C PATCHES, TYPE III, 13 INCH	CLASS C PATCHES, TYPE IV, 13 INCH
	(MILES)	(FOOT)	(FOOT)	(SQ YD)	(SQ YD)	(SQ YD)	(SQ YD)	(SQ YD)
<b>IL 146 UNION COUNTY</b>								
WB	0	5	12	7		7		
WB		6	12	8		8		
WB		6	12	8		8		
WB		4	12	6		6		
WB	0.1	6	12	8		8		
WB		4	12	6		6		
WB		5	12	7		7		
WB		4	12	6		6		
WB		4	12	6		6		
WB		5	12	7		7		
WB		4	12	6		6		
WB		8	12	11		11		
WB		4	12	6		6		
WB	0.2	8	12	11		11		
WB		4	12	6		6		
WB		4	12	6		6		
WB		4	12	6		6		
WB		4	12	6		6		
WB		4	12	6		6		
WB	0.3	4	12	6		6		
WB		20	12	27				27
WB		4	12	6		6		
WB		4	12	6		6		
WB		4	6	3	3			
WB		8	12	11		11		
WB		8	12	11		11		
WB	0.4	8	12	11		11		
WB		4	12	6		6		
WB		6	12	8		8		
WB	0.5	6	12	8		8		
WB		6	12	8		8		
WB		8	12	11		11		
WB		6	12	8		8		
WB		12	12	16			16	
<b>WESTBOUND SUBTOTAL FOR LOCATION 1</b>					<b>3</b>	<b>241</b>	<b>16</b>	<b>27</b>
WB	0.6	10	6	7		7		
WB	0.7	6	12	8		8		
WB		6	12	8		8		
WB		8	12	11		11		
WB		4	12	6		6		

MODEL: Patching Schedule Continued (Sheet)  
FILE NAME: c:\p\work\146\illinois.gov\_nadia.mcMichael\illinois.gov\_nadia.mcMichael@illinois.gov\_146-SHE-Schedules.dgn

USER NAME = Nadia.McMichael	DESIGNED -	REVISED -
	DRAWN -	REVISED -
	CHECKED -	REVISED -
PLOT DATE = 8/8/2024	DATE -	REVISED -

**STATE OF ILLINOIS  
DEPARTMENT OF TRANSPORTATION**

**PATCHING SCHEDULES**

SCALE: SHEET 15 OF 22 SHEETS STA. TO STA.

F.A.P. RTE.	SECTION	COUNTY	TOTAL SHEETS	SHEET NO.
885	106RS-6	UNION	22	15
CONTRACT NO. 78A71				
ILLINOIS FED. AID PROJECT				

## WESTBOUND PATCHING SCHEDULE CONTD

LANE	DISTANCE FROM PROJECT START	LENGTH	WIDTH	AREA	CLASS C PATCHES, TYPE I, 13 INCH	CLASS C PATCHES, TYPE II, 13 INCH	CLASS C PATCHES, TYPE III, 13 INCH	CLASS C PATCHES, TYPE IV, 13 INCH
	(MILES)	(FOOT)	(FOOT)	(SQ YD)	(SQ YD)	(SQ YD)	(SQ YD)	(SQ YD)
<b>IL 146 UNION COUNTY</b>								
WB		4	12	6		6		
WB		5	12	7		7		
WB	0.8	7	12	10		10		
WB		12	12	16			16	
WB	0.9	12	12	16			16	
WB		6	6	4	4			
WB		8	12	11		11		
WB		6	12	8		8		
WB		7	12	10		10		
WB		5	12	7		7		
WB		10	12	14		14		
WB		4	12	6		6		
WB	1	6	12	8		8		
WB		6	12	8		8		
WB		6	12	8		8		
WB		6	12	8		8		
WB	1.1	4	12	6		6		
WB		5	12	7		7		
WB		5	12	7		7		
WB	1.2	6	12	8		8		
WB		6	12	8		8		
WB		6	12	8		8		
WB		6	12	8		8		
WB		4	12	6		6		
WB		6	12	8		8		
WB	1.3	4	12	6		6		
WB		4	12	6		6		
WB		4	12	6		6		
WB		5	12	7		7		
<b>WESTBOUND SUBTOTAL FOR LOCATION 2</b>					<b>4</b>	<b>242</b>	<b>32</b>	
WB	1.4	6	12	8		8		
WB		6	12	8		8		
WB	1.5	6	12	8		8		
WB	1.6	4	12	6		6		
WB		6	12	8		8		
WB		4	12	6		6		
WB		4	12	6		6		
WB	1.7	8	12	11		11		
WB		4	12	6		6		
WB		8	12	11		11		
WB	1.8	6	12	8		8		

## WESTBOUND PATCHING SCHEDULE CONTD

LANE	DISTANCE FROM PROJECT START	LENGTH	WIDTH	AREA	CLASS C PATCHES, TYPE I, 13 INCH	CLASS C PATCHES, TYPE II, 13 INCH	CLASS C PATCHES, TYPE III, 13 INCH	CLASS C PATCHES, TYPE IV, 13 INCH
	(MILES)	(FOOT)	(FOOT)	(SQ YD)	(SQ YD)	(SQ YD)	(SQ YD)	(SQ YD)
<b>IL 146 UNION COUNTY</b>								
WB		10	12	14		14		
WB		8	12	11		11		
WB	1.9	8	12	11		11		
WB		4	12	6		6		
WB		4	12	6		6		
WB	2	6	12	8		8		
WB		12	6	8		8		
WB		8	12	11		11		
WB		6	12	8		8		
WB		6	12	8		8		
WB		4	12	6		6		
WB		6	12	8		8		
WB		4	12	6		6		
WB	2.1	6	12	8		8		
WB	2.2	4	12	6		6		
WB		4	12	6		6		
WB		6	12	8		8		
WB	2.3	6	12	8		8		
WB		6	12	8		8		
WB	2.4	6	12	8		8		
WB		7	12	10		10		
WB		4	12	6		6		
WB		8	12	11		11		
WB		4	12	6		6		
WB	2.5	5	12	7		7		
WB	2.6	4	12	6		6		
WB		8	12	11		11		
WB		8	12	11		11		
WB		4	12	6		6		
WB		8	12	11		11		
WB		4	12	6		6		
WB	2.7	4	4	2	2			
WB		6	12	8		8		
WB		10	12	14		14		
WB	2.8	4	12	6		6		
WB		8	12	11		11		
WB		5	12	7		7		
WB		4	12	6		6		
WB		6	12	8		8		
WB	3.0	4	12	6		6		
WB		6	12	8		8		
WB		6	12	8		8		

MODEL: Patching Schedule Continued-1 [Sheet]  
 FILE NAME: c:\p\work\pwr\illinois.gov\_nadia.mcMichael@illinois.gov\0986609\0978A71-SHE-Schedules.dgn

USER NAME = Nadia.McMichael	DESIGNED -	REVISED -
	DRAWN -	REVISED -
	CHECKED -	REVISED -
PLOT DATE = 8/8/2024	DATE -	REVISED -

**STATE OF ILLINOIS  
DEPARTMENT OF TRANSPORTATION**

**PATCHING SCHEDULES**

SCALE: SHEET 16 OF 22 SHEETS STA. TO STA.

F.A.P. RTE.	SECTION	COUNTY	TOTAL SHEETS	SHEET NO.
885	106RS-6	UNION	22	16
CONTRACT NO. 78A71				
ILLINOIS FED. AID PROJECT				



## WESTBOUND PATCHING SCHEDULE CONTD

LANE	DISTANCE FROM PROJECT START	LENGTH	WIDTH	AREA	CLASS C PATCHES, TYPE I, 13 INCH	CLASS C PATCHES, TYPE II, 13 INCH	CLASS C PATCHES, TYPE III, 13 INCH	CLASS C PATCHES, TYPE IV, 13 INCH
	(MILES)	(FOOT)	(FOOT)	(SQ YD)	(SQ YD)	(SQ YD)	(SQ YD)	(SQ YD)
<b>IL 146 UNION COUNTY</b>								
WB		6	12	8		8		
WB	3.1	4	12	6		6		
WB		6	12	8		8		
WB	3.2	6	4	3	3			
WB		8	12	11		11		
WB	3.4	6	12	8		8		
WB		6	12	8		8		
WB	3.5	4	12	6		6		
WB		6	12	8		8		
WB		4	12	6		6		
WB		6	12	8		8		
WB		4	12	6		6		
WB	3.6	6	12	8		8		
WB		8	12	11		11		
WB		4	12	6		6		
WB	3.7	4	12	6		6		
WB		8	12	11		11		
WB	3.8	4	12	6		6		
WB		6	12	8		8		
WB	3.9	7	12	10		10		
WB		6	12	8		8		
WB		6	4	3	3		20	
WB	4	15	12	20				
WB	4.2	10	12	14		14		
WB		6	12	8		8		
WB	4.3	6	12	8		8		
WB		4	12	6		6		
WB	4.4	6	12	8		8		
WB		7	12	10		10		
WB		5	12	7		7		
WB	4.5	6	12	8		8		
WB		6	4	3	3			
WB		4	12	6		6		
WB		4	12	6		6		
WB		4	12	6		6		
WB		8	12	11		11		
WB	4.6	4	12	6		6		
WB		4	12	6		6		
WB		4	12	6		6		
WB		12	4	6		6		
WB	4.7	5	12	7		7		

## WESTBOUND PATCHING SCHEDULE CONTD

LANE	DISTANCE FROM PROJECT START	LENGTH	WIDTH	AREA	CLASS C PATCHES, TYPE I, 13 INCH	CLASS C PATCHES, TYPE II, 13 INCH	CLASS C PATCHES, TYPE III, 13 INCH	CLASS C PATCHES, TYPE IV, 13 INCH
	(MILES)	(FOOT)	(FOOT)	(SQ YD)	(SQ YD)	(SQ YD)	(SQ YD)	(SQ YD)
<b>IL 146 UNION COUNTY</b>								
WB		4	12	6		6		
WB	4.8	4	12	6		6		
WB		4	12	6		6		
WB		4	12	6		6		
WB	4.9	4	12	6		6		
WB		4	12	6		6		
WB	5	4	12	6		6		
WB		5	12	7		7		
WB		5	12	7		7		
WB		4	12	6		6		
WB		6	12	8		8		
WB		4	12	6		6		
WB	5.1	6	12	8		8		
WB	5.2	4	12	6		6		
WB		5	12	7		7		
WB		5	12	7		7		
WB		4	12	6		6		
WB		4	12	6		6		
WB		5	12	7		7		
WB	5.3	4	12	6		6		
WB		4	12	6		6		
WB		8	12	11		11		
WB		4	12	6		6		
WB		4	12	6		6		
WB		4	12	6		6		
WB		4	12	6		6		
WB		5	12	7		7		
WB	5.4	4	12	6		6		
WB	5.5	6	4	3	3			
WB	5.6	4	12	6		6		
WB		5	12	7		7		
WB		8	6	6		6		
WB		6	5	4	4			
WB		4	12	6		6		
WB	5.7	4	12	6		6		
WB		4	12	6		6		
WB		8	12	11		11		
WB		7	5	4	4			
WB	5.9	4	12	6		6		

MODEL: Patching Schedule Continued-2 (Sheet)  
FILE NAME: c:\p\work\pwr\illinois.gov\_nadia.mcMichael@illinois.gov\146-Union-County-Schedule-Continued-2.dgn

USER NAME = Nadia.McMichael	DESIGNED -	REVISED -
	DRAWN -	REVISED -
	CHECKED -	REVISED -
PLOT DATE = 8/8/2024	DATE -	REVISED -

**STATE OF ILLINOIS  
DEPARTMENT OF TRANSPORTATION**

**PATCHING SCHEDULES**

SCALE: SHEET 17 OF 22 SHEETS STA. TO STA.

F.A.P. RTE.	SECTION	COUNTY	TOTAL SHEETS	SHEET NO.
885	106RS-6	UNION	22	17
CONTRACT NO. 78A71				
ILLINOIS FED. AID PROJECT				

## WESTBOUND PATCHING SCHEDULE CONTD

LANE	DISTANCE FROM PROJECT START	LENGTH	WIDTH	AREA	CLASS C PATCHES, TYPE I, 13 INCH	CLASS C PATCHES, TYPE II, 13 INCH	CLASS C PATCHES, TYPE III, 13 INCH	CLASS C PATCHES, TYPE IV, 13 INCH
	(MILES)	(FOOT)	(FOOT)	(SQ YD)	(SQ YD)	(SQ YD)	(SQ YD)	(SQ YD)
<b>IL 146 UNION COUNTY</b>								
WB		4	12	6		6		
WB		4	12	6		6		
WB		6	4	3	3			
WB		4	12	6		6		
WB		10	12	14		14		
WB		4	12	6		6		
WB	6	4	12	6		6		
<b>WESTBOUND SUBTOTAL FOR LOCATION 3</b>					<b>25</b>	<b>998</b>	<b>20</b>	
<b>WESTBOUND TOTAL</b>					<b>32</b>	<b>1481</b>	<b>68</b>	<b>27</b>

## TOTAL PATCHING

LOCATION	CLASS C PATCHES, TYPE I, 13 INCH	CLASS C PATCHES, TYPE II, 13 INCH	CLASS C PATCHES, TYPE III, 13 INCH	CLASS C PATCHES, TYPE IV, 13 INCH
	(SQ YD)	(SQ YD)	(SQ YD)	(SQ YD)
<b>IL 146 UNION COUNTY</b>				
<b>SUBTOTAL FOR LOCATION 1</b>	<b>6</b>	<b>436</b>	<b>36</b>	<b>27</b>
<b>SUBTOTAL FOR LOCATION 2</b>	<b>8</b>	<b>508</b>	<b>84</b>	
<b>SUBTOTAL FOR LOCATION 3</b>	<b>30</b>	<b>1869</b>	<b>74</b>	
<b>PROJECT TOTAL</b>	<b>44</b>	<b>2813</b>	<b>194</b>	<b>27</b>

MODEL: Patching Schedule Continued-3 [Sheet]  
 FILE NAME: c:\p\work\wv\illinois.gov\_nadia.mcMichael@illinois.gov\0978A71-SHE-Schedules.dgn

USER NAME = Nadia.McMichael	DESIGNED -	REVISED -
	DRAWN -	REVISED -
	CHECKED -	REVISED -
PLOT DATE = 8/8/2024	DATE -	REVISED -

**STATE OF ILLINOIS  
DEPARTMENT OF TRANSPORTATION**

**PATCHING SCHEDULES**

SCALE: SHEET 18 OF 22 SHEETS STA. TO STA.

F.A.P. RTE.	SECTION	COUNTY	TOTAL SHEETS	SHEET NO.
885	106RS-6	UNION	22	18
CONTRACT NO. 78A71				
ILLINOIS FED. AID PROJECT				

# TEMPORARY PAVEMENT MARKING SCHEDULE

LOCATION STATION TO STATION	LENGTH  (FOOT)	TEMPORARY PAVEMENT MARKING				TEMPORARY PAVEMENT MARKING REMOVAL (GRINDING)  (SQ FT)	SHORT TERM PAVEMENT MARKING  (FOOT)	SHORT TERM PAVEMENT MARKING REMOVAL  (SQ FT)	REMARKS
		LINE 4"							
		YELLOW			WHITE				
		DBL SOLID  (FOOT)	SOLID  (FOOT)	SKIP DASH  (FOOT)	SOLID  (FOOT)				
<b>IL 146 UNION COUNTY</b>									
247+91.00 TO 249+67.00	176		176	44	352	191	48	16	EB LN NO PASS ZONE
249+67.00 TO 279+21.76	2955			739	5910	2217	806	269	PASS ZONE
<b>SUBTOTAL FOR LOCATION 1</b>	<b>3131</b>		<b>176</b>	<b>783</b>	<b>6262</b>	<b>2408</b>	<b>854</b>	<b>285</b>	
<b>TOTAL 1</b>			<b>7221</b>						
279+21.76 TO 320+73.00	4151			1038	8303	3114	1133	378	PASS ZONE
320+73.00 TO 321+00.00	27		27	7	54	30	8	3	WB LN NO PASS ZONE
<b>SUBTOTAL FOR LOCATION 2</b>	<b>4178</b>		<b>27</b>	<b>1045</b>	<b>8357</b>	<b>3144</b>	<b>1141</b>	<b>381</b>	
<b>TOTAL 2</b>			<b>9429</b>						
321+00.00 TO 331+54.00	1054		1054	264	2108	1142	288	96	WB LN NO PASS ZONE
331+54.00 TO 340+57.00	903		903	226	1806	979	247	83	EB LN NO PASS ZONE
340+57.00 TO 356+46.00	1589			398	3178	1192	434	145	PASS ZONE
356+46.00 TO 367+87.00	1141		1141	286	2282	1237	312	104	WB LN NO PASS ZONE
367+87.00 TO 392+53.00	2466	4932			4932	3288	673	225	NO PASS ZONE
392+53.00 TO 398+44.00	591		591	148	1182	641	162	54	EB LN NO PASS ZONE
398+44.00 TO 403+77.00	533	1066			1066	711	146	49	NO PASS ZONE
403+77.00 TO 408+74.00	497		497	125	994	539	136	46	WB LN NO PASS ZONE
408+74.00 TO 420+30.00	1156	2312			2312	1542	316	106	NO PASS ZONE
420+30.00 TO 427+43.00	713		713	179	1426	773	195	65	EB LN NO PASS ZONE
427+43.00 TO 429+59.00	216	432			432	288	59	20	NO PASS ZONE
429+59.00 TO 438+41.00	882		882	221	1764	956	241	81	WB LN NO PASS ZONE
438+41.00 TO 460+80.00	2239	4478			4478	2986	611	204	NO PASS ZONE
460+80.00 TO 465+55.00	475		475	119	950	515	130	44	WB LN NO PASS ZONE
465+55.00 TO 501+98.00	3643	7286			7286	4858	994	332	NO PASS ZONE
501+98.00 TO 512+38.00	1040		1040	260	2080	1127	284	95	EB LN NO PASS ZONE
512+38.00 TO 523+31.00	1093		1093	274	2186	1185	299	100	WB LN NO PASS ZONE
523+31.00 TO 537+73.00	1442	2884			2884	1923	394	132	NO PASS ZONE
537+73.00 TO 549+39.00	1166		1166	292	2332	1264	318	106	EB LN NO PASS ZONE
549+39.00 TO 552+93.00	354			89	708	266	97	33	PASS ZONE
552+93.00 TO 562+54.00	961		961	241	1922	1042	263	88	WB LN NO PASS ZONE
562+54.00 TO 566+61.00	407	814			814	543	111	37	NO PASS ZONE
<b>SUBTOTAL FOR LOCATION 3</b>	<b>24561</b>	<b>24204</b>	<b>10516</b>	<b>3122</b>	<b>49122</b>	<b>28997</b>	<b>6710</b>	<b>2245</b>	
<b>TOTAL 3</b>			<b>86964</b>						
<b>PROJECT TOTAL</b>	<b>31870</b>		<b>103614</b>			<b>34549</b>	<b>8705</b>	<b>2911</b>	

MODEL - Short Term Pavement Marking Schedule (Sheet)  
FILE NAME: c:\pwworking\illinois.gov\ndia.mcMichael@illinois.gov\ndia.mcMichael.dgn

USER NAME = Nadia.McMichael	DESIGNED -	REVISED -
	DRAWN -	REVISED -
	CHECKED -	REVISED -
PLOT DATE = 8/8/2024	DATE -	REVISED -

**STATE OF ILLINOIS  
DEPARTMENT OF TRANSPORTATION**

**TEMPORARY PAVEMENT MARKING  
SCHEDULE**

SCALE: SHEET 19 OF 22 SHEETS STA. TO STA.

F.A.P. RTE.	SECTION	COUNTY	TOTAL SHEETS	SHEET NO.
885	106RS-6	UNION	22	19
CONTRACT NO. 78A71				
ILLINOIS FED. AID PROJECT				

# PAVEMENT MARKING SCHEDULE

LOCATION STATION TO STATION	LENGTH  (FOOT)	PAINT PAVEMENT MARKING LINE 4"				RAISED REFLECTIVE PAVEMENT MARKER  EACH	RAISED REFLECTIVE PAVEMENT MARKER REMOVAL  EACH	REMARKS
		YELLOW			WHITE			
		DBL SOLID	SOLID	SKIP DASH	SOLID			
		(FOOT)	(FOOT)	(FOOT)	(FOOT)			
<b>IL 146 UNION COUNTY</b>								
247+91.00 TO 249+67.00	176		176	44	352	3	3	EB LN NO PASS ZONE
249+67.00 TO 279+21.76	2955			739	5910	37	37	PASS ZONE
<b>SUBTOTAL FOR LOCATION 1</b>	<b>3131</b>		<b>176</b>	<b>783</b>	<b>6262</b>	<b>40</b>	<b>40</b>	
<b>TOTAL 1</b>			<b>7221</b>					
279+21.76 TO 320+73.00	4151			1038	8303	52	52	PASS ZONE
320+73.00 TO 321+00.00	27		27	7	54	1	1	WB LN NO PASS ZONE
<b>SUBTOTAL FOR LOCATION 2</b>	<b>4178</b>		<b>27</b>	<b>1045</b>	<b>8357</b>	<b>53</b>	<b>53</b>	
<b>TOTAL 2</b>			<b>9429</b>					
321+00.00 TO 331+54.00	1054		1054	264	2108	14	14	WB LN NO PASS ZONE
331+54.00 TO 340+57.00	903		903	226	1806	12	12	EB LN NO PASS ZONE
340+57.00 TO 356+46.00	1589			398	3178	20	20	PASS ZONE
356+46.00 TO 367+87.00	1141		1141	286	2282	15	15	WB LN NO PASS ZONE
367+87.00 TO 392+53.00	2466	4932			4932	31	31	NO PASS ZONE
392+53.00 TO 398+44.00	591		591	148	1182	8	8	EB LN NO PASS ZONE
398+44.00 TO 403+77.00	533	1066			1066	7	7	NO PASS ZONE
403+77.00 TO 408+74.00	497		497	125	994	7	7	WB LN NO PASS ZONE
408+74.00 TO 420+30.00	1156	2312			2312	15	15	NO PASS ZONE
420+30.00 TO 427+43.00	713		713	179	1426	9	9	EB LN NO PASS ZONE
427+43.00 TO 429+59.00	216	432			432	3	3	NO PASS ZONE
429+59.00 TO 438+41.00	882		882	221	1764	12	12	WB LN NO PASS ZONE
438+41.00 TO 460+80.00	2239	4478			4478	28	28	NO PASS ZONE
460+80.00 TO 465+55.00	475		475	119	950	6	6	WB LN NO PASS ZONE
465+55.00 TO 501+98.00	3643	7286			7286	46	46	NO PASS ZONE
501+98.00 TO 512+38.00	1040		1040	260	2080	13	13	EB LN NO PASS ZONE
512+38.00 TO 523+31.00	1093		1093	274	2186	14	14	WB LN NO PASS ZONE
523+31.00 TO 537+73.00	1442	2884			2884	19	19	NO PASS ZONE
537+73.00 TO 549+39.00	1166		1166	292	2332	15	15	EB LN NO PASS ZONE
549+39.00 TO 552+93.00	354			89	708	5	5	PASS ZONE
552+93.00 TO 562+54.00	961		961	241	1922	13	13	WB LN NO PASS ZONE
562+54.00 TO 566+61.00	407	814			814	6	6	NO PASS ZONE
<b>SUBTOTAL FOR LOCATION 3</b>	<b>24561</b>	<b>24204</b>	<b>10516</b>	<b>3122</b>	<b>49122</b>	<b>318</b>	<b>318</b>	
<b>TOTAL 3</b>			<b>86964</b>					
<b>PROJECT TOTAL</b>	<b>31870</b>		<b>103614</b>			<b>411</b>	<b>411</b>	

MODEL: Pavement Marking Schedule (Sheet)  
 FILE NAME: c:\p\work\pav\illinois.gov\_nadia.mcmichael@illinois.gov\_nadia.mcmichael@illinois.gov

USER NAME = Nadia.McMichael	DESIGNED -	REVISED -
	DRAWN -	REVISED -
	CHECKED -	REVISED -
PLOT DATE = 8/8/2024	DATE -	REVISED -

**STATE OF ILLINOIS  
DEPARTMENT OF TRANSPORTATION**

**PAVEMENT MARKING SCHEDULE**

SCALE: SHEET 20 OF 22 SHEETS STA. TO STA.

F.A.P. RTE.	SECTION	COUNTY	TOTAL SHEETS	SHEET NO.
885	106RS-6	UNION	22	20
CONTRACT NO. 78A71				
ILLINOIS FED. AID PROJECT				

# IL 146 HOT-MIX ASPHALT PAVEMENT TRANSITION

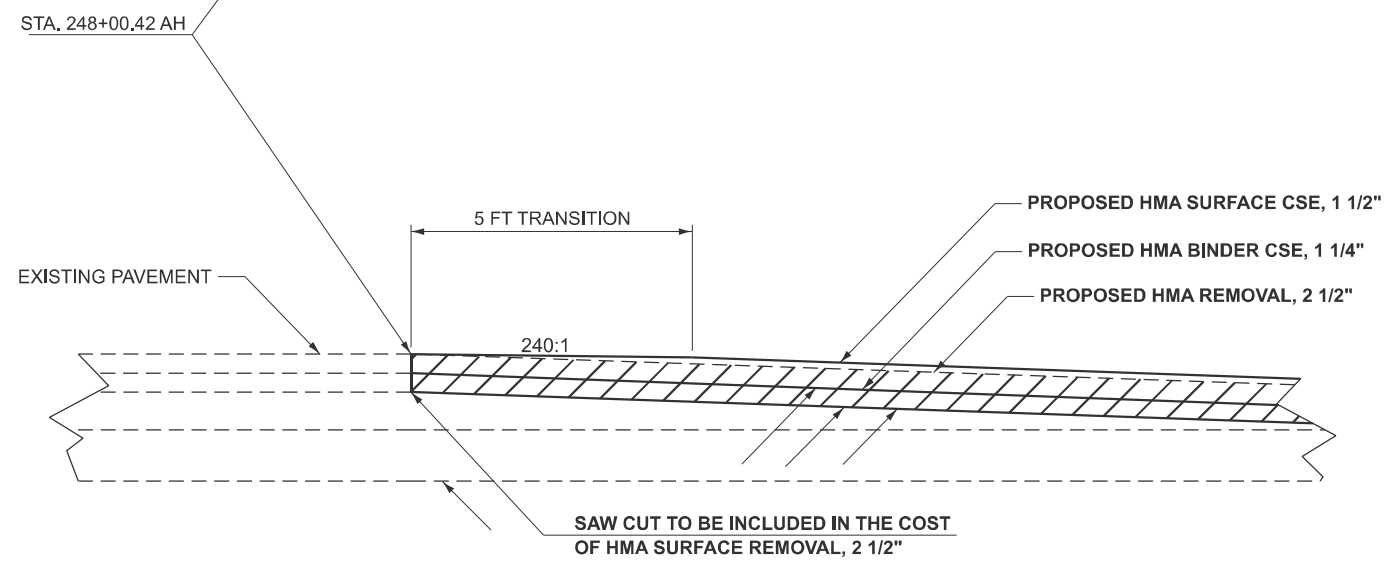
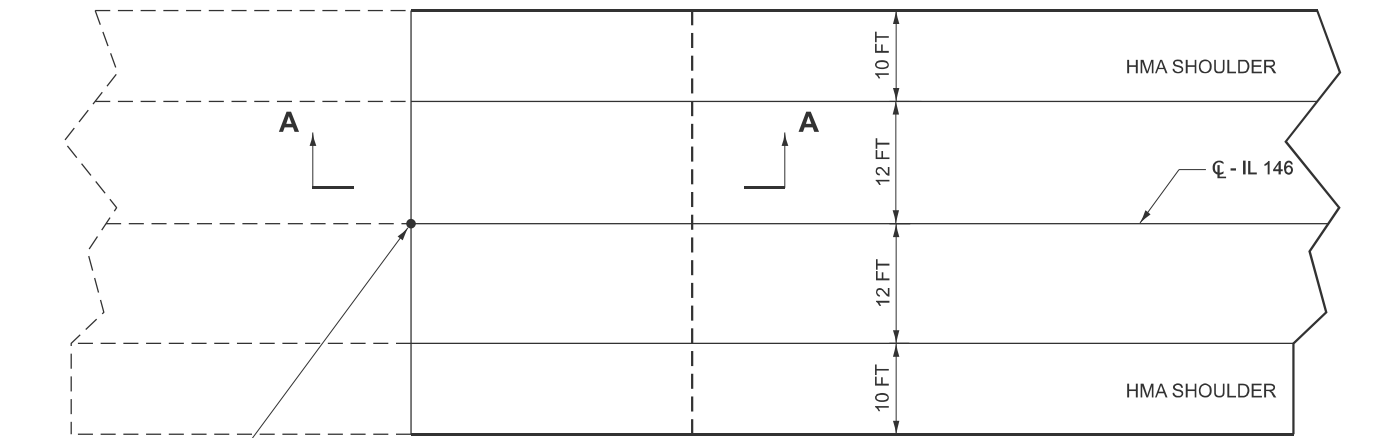

**SECTION A-A**

# IL 146 HOT-MIX ASPHALT PAVEMENT TRANSITION

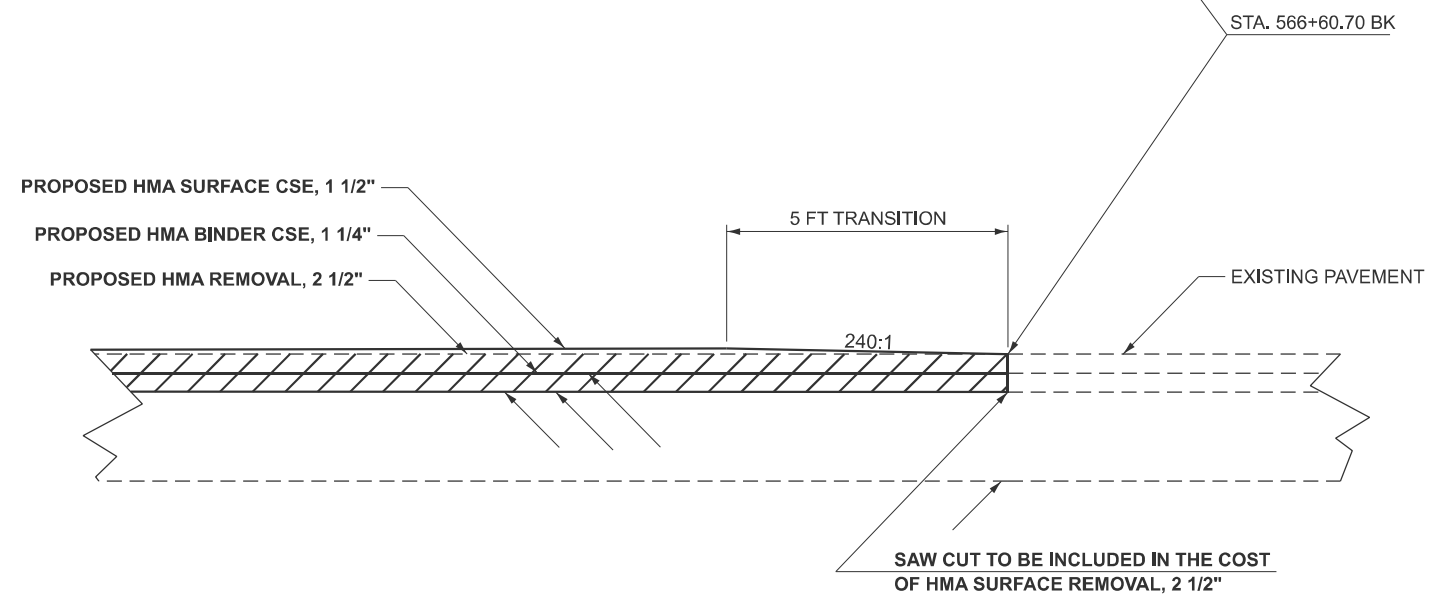
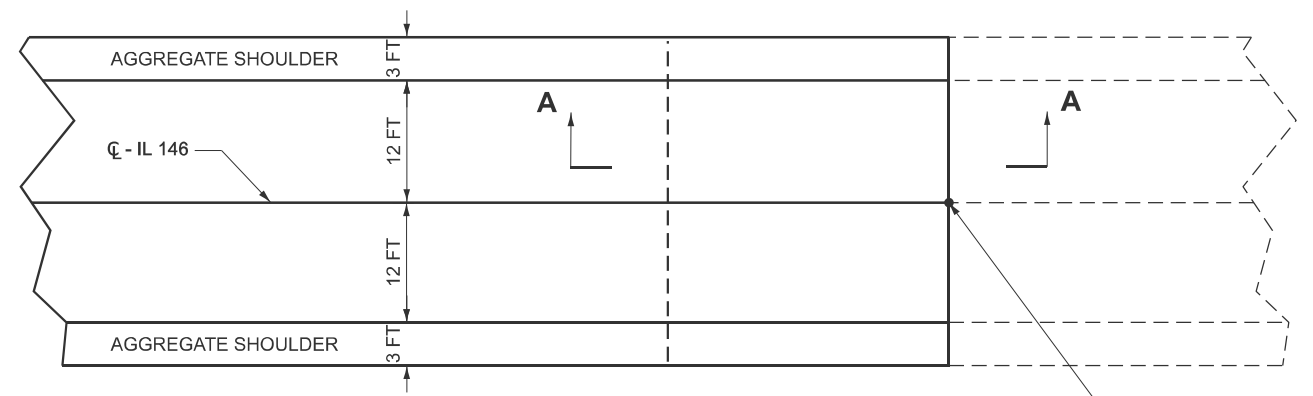

**SECTION A-A**

MODEL: Pavement Details 3 (Sheet)  
FILE NAME: c:\p\work\pav\illinois.gov\_nadia.mcMichael@illinois.gov\0986609\0978A71-SHS-District\GIS.dgn

USER NAME = Nadia.McMichael	DESIGNED -	REVISED -
	DRAWN -	REVISED -
	CHECKED -	REVISED -
PLOT DATE = 8/6/2024	DATE -	REVISED -

**STATE OF ILLINOIS  
DEPARTMENT OF TRANSPORTATION**

**HMA TRANSITION  
DETAILS**

SCALE: SHEET 21 OF 22 SHEETS STA. TO STA.

F.A.P. RTE.	SECTION	COUNTY	TOTAL SHEETS	SHEET NO.
885	106RS-6	UNION	22	21
CONTRACT NO. 78A71				
ILLINOIS FED. AID PROJECT				

## TEMPORARY HOT-MIX ASPHALT TRANSITIONS

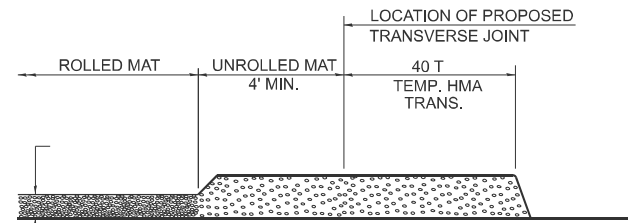

### STEP I

1. PLACE HOT-MIX ASPHALT MAT, LENGTH 40 TIMES THE THICKNESS OF THE MAT BEING PLACED PAST THE PROPOSED TRANSVERSE JOINT LOCATION USING NORMAL OPERATING PROCEDURES.
2. EXTREME CARE SHOULD BE TAKEN TO MAINTAIN ENOUGH MATERIAL IN FRONT OF THE SCREED TO MAINTAIN REQUIRED PAVING DEPTH.

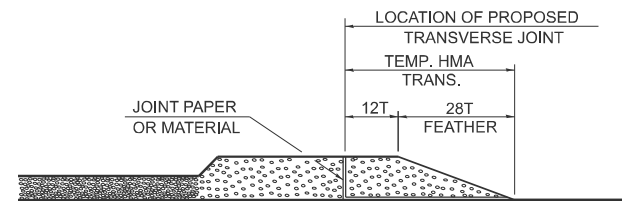

### STEP III

1. JOINT PAPER OR OTHER PRESELECTED JOINT MATERIAL IS THEN PLACED IN THE CLEARED AREA AND THE EXCESS ASPHALT USED TO HAND FORM A TRANSITION TO THE DIMENSIONS SHOWN ABOVE.
2. NOTE THAT IN CONSTRUCTING THE TRANSITION, THE MAT DEPTH IS CONTINUED AS PART OF THE TRANSITION BEFORE FORMING THE FEATHER.

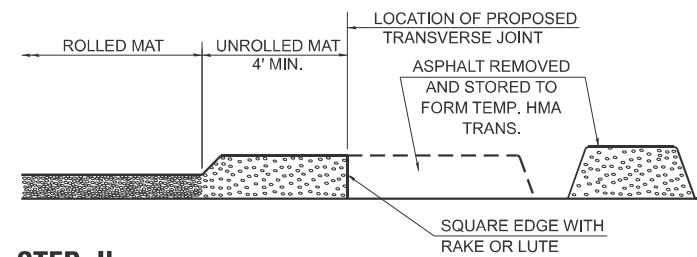

### STEP II

1. MOVE THE PAVER OUT OF THE WAY AND REMOVE THE ASPHALT FROM THE AREA OF THE PROPOSED TEMPORARY HOT-MIX ASPHALT TRANSITION.
2. SQUARE UP THE END OF THE MAT WITH A RAKE OR LUTE.
3. NOTE THAT THE MAT WITHIN 4' OF THE END OF JOINT IS NOT TO BE ROLLED AT THIS TIME.

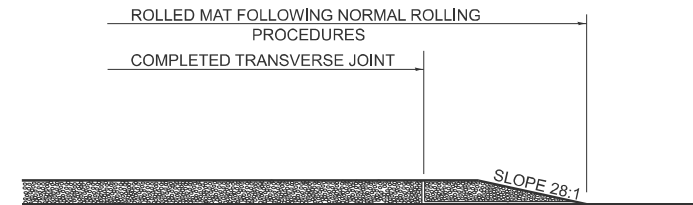

### STEP IV

1. COMPLETE TEMPORARY TRANSITION BY ROLLING.
2. TO RESUME PAVING, AT THE JOINT, REMOVE TEMPORARY TRANSITION AND DISPOSE OF THE MATERIAL ACCORDING TO ART. 202.03 OF THE STD. SPECS. (COST INCLUDED IN THE CONTRACT).
3. CONSTRUCTING THE TEMPORARY TRANSITIONS WILL NOT BE PAID FOR SEPARATELY IN ACCORDANCE WITH ARTICLE 406.14 OF THE STANDARD SPECIFICATIONS.

DRAWN	02-15-89
REVISED	01-09-07
REVISED	10-21-21
REVISED	05-26-22

STD. 9-18

## ENTRANCE AND SIDE ROAD TEMPORARY HMA TRANSITION

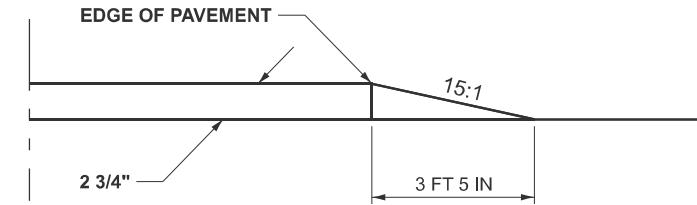

## ILLINOIS STANDARD ROUGH GROOVED SURFACE SIGN

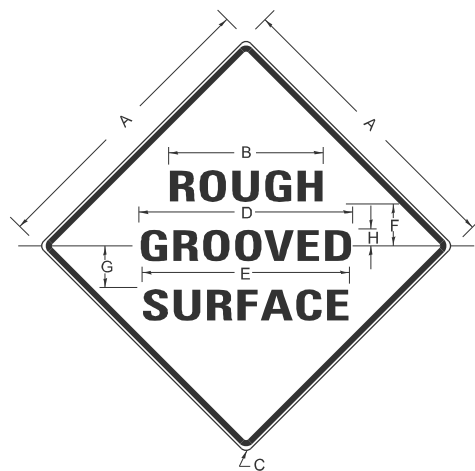

### COLORS

LEGEND AND BORDER- BLACK NON-REFLECTORIZED  
BACKGROUND- ORANGE REFLECTORIZED

SIGN SIZE	DIMENSIONS							
	A	B	C	D	E	F	G	H
48X48	48.0	24.1	3.0	34.0	33.0	6.0	13.0	3.5

SIGN SIZE	SERIES LINES			MAR-GIN	BOR-DER	BLANK STD.
	1	2	3			
48X48	7C	7C	7C	0.8	1.2	B4-48D

ALL DIMENSIONS IN INCHES

### NOTES

PRIOR TO ALLOWING TRAFFIC ON ANY PORTION OF THE ROADWAY THAT HAS BEEN COLDMILLED, THE CONTRACTOR SHALL HAVE ERECTED "ROUGH GROOVED SURFACE" SIGNS THAT CONFORM TO THE ABOVE DETAILS. A MINIMUM OF ONE SIGN AT EACH END OF THE IMPROVEMENT WILL BE REQUIRED. THE CONTRACTOR SHALL MAINTAIN THE "ROUGH GROOVED SURFACE" SIGNS UNTIL THE COLDMILLED SURFACE IS COVERED WITH LEVELING BINDER OR SURFACE COURSE.

IF AT ANY TIME THE SIGNS ARE IN PLACE BUT NOT APPLICABLE, THEY SHALL BE TURNED FROM THE VIEW OF MOTORISTS OR COVERED AS DIRECTED BY THE ENGINEER.

THE COST OF FURNISHING, ERECTING, MAINTAINING, AND REMOVING THE REQUIRED SIGNS SHALL BE INCLUDED IN THE CONTRACT.

DRAWN	02-15-89
REVISED	03-27-08
REVISED	10-21-21
REVISED	05-27-22

STD. 9-23

## UNEVEN LANES SIGN W8-11 (48" X 48")

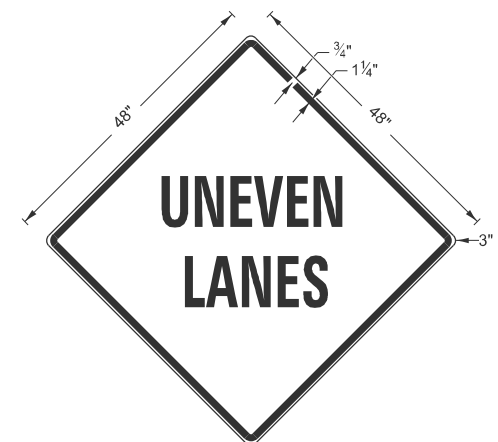

### COLORS:

LEGEND AND BORDER - BLACK NON-REFLECTORIZED  
BACKGROUND - ORANGE REFLECTORIZED

NOTE: PRIOR TO ALLOWING TRAFFIC ON ANY PORTION OF THE ROADWAY THAT HAS BEEN COLDMILLED OR BEFORE RESURFACING OPERATIONS BEGIN, THE CONTRACTOR SHALL HAVE ERECTED "UNEVEN PAVEMENT" SIGNS THAT CONFORM TO THE ABOVE DETAILS. A MINIMUM OF ONE SIGN AT EACH END OF THE IMPROVEMENT WILL BE REQUIRED. THE CONTRACTOR SHALL MAINTAIN THE "UNEVEN PAVEMENT" SIGNS UNTIL THE RESURFACING OPERATIONS ARE COMPLETED.

IF AT ANY TIME THE SIGNS ARE IN PLACE BUT NOT APPLICABLE, THEY SHALL BE TURNED FROM THE VIEW OF MOTORISTS OR COVERED AS DIRECTED BY THE ENGINEER.

THE COST OF FURNISHING, ERECTING, MAINTAINING, AND REMOVING THE REQUIRED SIGNS SHALL BE INCLUDED IN THE CONTRACT.

DRAWN	02-15-89
REVISED	05-08-08
REVISED	10-21-21
REVISED	05-27-22

STD. 9-24

MODEL - Pavement Details 6 (Sheet)  
FILE NAME - c:\p\work\wv\illinois\illinois\mcmichael@illinois.gov\0978A71-SHS-District\6\6.dgn

USER NAME = Nadia.McMichael	DESIGNED -	REVISED -
	DRAWN -	REVISED -
	CHECKED -	REVISED -
PLOT DATE = 8/5/2024	DATE -	REVISED -

STATE OF ILLINOIS  
DEPARTMENT OF TRANSPORTATION

TEMPORARY TRANSITIONS, ROUGH GROOVED SURFACE, &  
UNEVEN LANES DETAILS

SCALE: SHEET 22 OF 22 SHEETS STA. TO STA.

F.A.P. RTE.	SECTION	COUNTY	TOTAL SHEETS	SHEET NO.
885	106RS-6	UNION	22	22
CONTRACT NO. 78A71				
ILLINOIS FED. AID PROJECT				