

11-08-2024 LETTING ITEM 107

# STATE OF ILLINOIS

## DEPARTMENT OF TRANSPORTATION

# PLANS FOR PROPOSED FEDERAL AID HIGHWAY

**FAU 3783 (BURLINGTON AVENUE)  
CENTRAL AVENUE TO WOLF ROAD  
RESURFACING  
SECTION: 23-00104-00-RS  
PROJECT: 11R0(610)  
VILLAGE OF WESTERN SPRINGS  
COOK COUNTY**

FOR INDEX OF SHEETS, SEE SHEET NO. 2

FOR INDEX OF HIGHWAY STANDARDS, SEE SHEET NO. 2

### TRAFFIC DATA

BURLINGTON AVENUE  
POSTED AND DESIGN SPEED LIMIT = 25 MPH  
ADT = 1250 (2022)  
ROADWAY CLASSIFICATION: MINOR COLLECTOR

F.A. RTE.	SECTION	COUNTY	TOTAL SHEETS	SHEET NO.
3783	23-00104-00-RS	COOK	20	1
11R0(610)		ILLINOIS CONTRACT NO. 61K56		

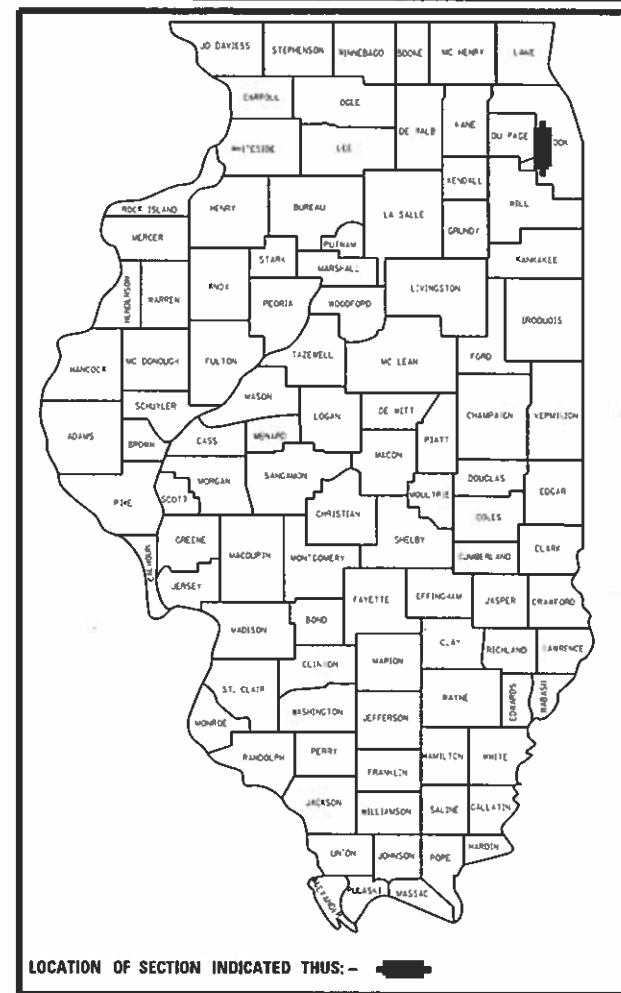

C-91-291-24  
LOCATION MAP  
NOT TO SCALE

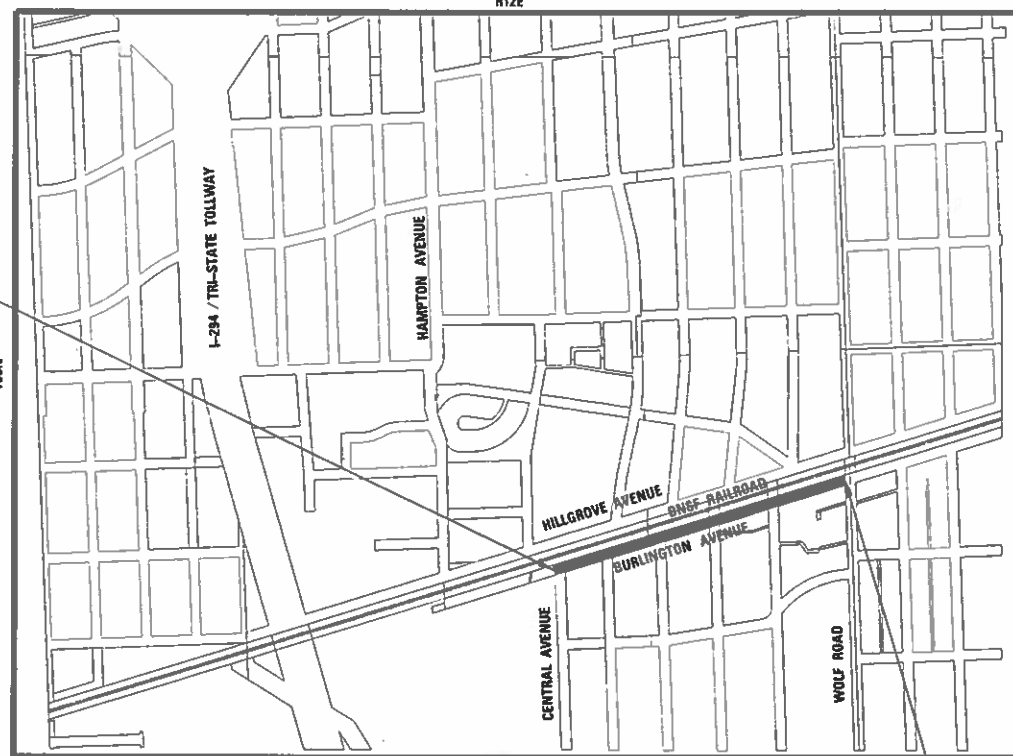

BURLINGTON AVENUE  
IMPROVEMENT BEGINS  
STA 11+12

BURLINGTON AVENUE  
IMPROVEMENT ENDS  
STA 26+96

GROSS LENGTH = 1,584 FT. = 0.30 MILE  
NET LENGTH = 1,584 FT. = 0.30 MILE

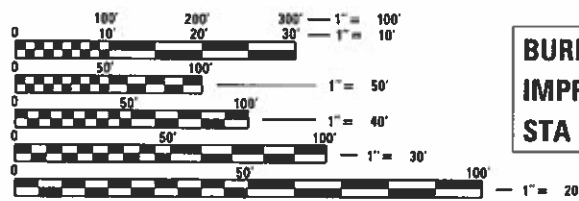

FULL SIZE PLANS HAVE BEEN PREPARED USING STANDARD ENGINEERING SCALES. REDUCED SIZED PLANS WILL NOT CONFORM TO STANDARD SCALES. IN MAKING MEASUREMENTS ON REDUCED PLANS, THE ABOVE SCALES MAY BE USED.

J.U.L.I.E. DESIGN STAGE REQUEST  
DIG. No. A240381747



CONTACT JULIE AT 811 OR 800-892-0123 WITH THE FOLLOWING:  
COUNTY = COOK  
CITY-TWNSHP. = WESTERN SPRINGS - LYONS  
SEC. & 1/4 SEC. NO. = 19  
48 HOURS (2 working days) BEFORE YOU DIG



SIGNED: 6/10/2024  
PROJECT MANAGER  
"LICENSE EXPIRES 11-30-2025"

STATE OF ILLINOIS DEPARTMENT OF TRANSPORTATION	
APPROVED	<i>[Signature]</i> 6/10/24
VILLAGE OF WESTERN SPRINGS DIRECTOR OF ENGINEERING SERVICES	
PASSED	<i>[Signature]</i> Sept. 9, 2024
DISTRICT 1 ENGINEER OF LOCAL ROADS AND STREETS	
RELEASING FOR BID BASED ON LIMITED REVIEW	<i>[Signature]</i> September 9/24
REGIONAL ENGINEER	

PRINTED BY THE AUTHORITY  
OF THE STATE OF ILLINOIS



12/19/24 12:19:19 PM ...:\projects\2325873\plan\2325873\Burlington Ave STP D:\CAD\06\_HR\loc\sub\sheet\107\107-Cover.dgn  
FEDERAL AID PROGRAM ENGINEER: CARMEN E. RAMOS, P.E., SCHAUMBURG, IL

**GENERAL NOTES**

- ALL CONSTRUCTION SHALL BE DONE IN ACCORDANCE WITH THE DETAILS IN THE PLANS, THE SPECIAL PROVISIONS INCLUDED IN THE CONTRACT DOCUMENTS, THE JANUARY 1, 2022 EDITION OF THE "THE STANDARD SPECIFICATIONS FOR ROAD AND BRIDGE CONSTRUCTION" (REFERRED TO AS THE "STANDARD SPECIFICATIONS"), THE JANUARY 1, 2024 EDITION OF THE "SUPPLEMENTAL SPECIFICATIONS AND RECURRING SPECIAL PROVISIONS", THE NOVEMBER 2021 REVISION OF THE "ILLINOIS SUPPLEMENT TO THE MANUAL ON UNIFORM TRAFFIC CONTROL DEVICES FOR STREETS AND HIGHWAYS", THE DECEMBER 1, 2022 EDITION OF THE "MANUAL OF TEST PROCEDURES FOR MATERIALS", AND THE 8<sup>th</sup> EDITION OF THE "STANDARD SPECIFICATIONS FOR WATER AND SEWER MAIN CONSTRUCTION IN ILLINOIS".
- THE LOCATIONS OF UTILITIES SHOWN ON THE PLANS REPRESENTS ONLY THE OPINION OF THE VILLAGE AND IS ONLY INCLUDED FOR THE CONVENIENCE OF THE BIDDER AND THE ACCURACY IS NOT GUARANTEED. THE CONTRACTOR SHALL BE RESPONSIBLE FOR THE PROTECTION OF ALL UNDERGROUND OR SURFACE UTILITIES, INCLUDING SPRINKLER SYSTEMS, EVEN THOUGH THEY MAY NOT BE SHOWN ON THE PLANS.
- THE CONTRACTOR SHALL NOTIFY THE VILLAGE PUBLIC WORKS ADMINISTRATOR AT LEAST 48 HOURS IN ADVANCE OF BEGINNING WORK TO OBTAIN VILLAGE UTILITY LOCATIONS.
- THE CONTRACTOR SHALL SUBMIT PARTIAL WAIVERS OF LIEN FROM ALL SUBCONTRACTORS AND SUPPLIERS WITH EACH PARTIAL PAYMENT ESTIMATE AND CONTRACTOR'S AFFIDAVIT FOR SUBCONTRACTORS AND SUPPLIERS WITH SECOND PAYMENT REQUEST FOR THE PREVIOUS PAYMENT ESTIMATES AND THEN WITH ALL SUBSEQUENT PAYMENT ESTIMATES.
- THE ENGINEER WILL FURNISH A RESIDENT ENGINEER (RE) TO ASSIST THE ENGINEER IN PROVIDING JOB-SITE OBSERVATION OF THE CONTRACTOR'S WORK. THE RE WILL PROVIDE BASE LINES, BENCHMARKS AND REFERENCE POINTS, ASSIST THE CONTRACTOR WITH INTERPRETATION OF THE PLANS AND SPECIFICATIONS, OBSERVE IN GENERAL IF THE CONTRACTOR'S WORK IS IN CONFORMITY WITH THE CONTRACT DOCUMENTS, AND MONITOR THE CONTRACTOR'S PROGRESS AS RELATED TO THE DATE OF COMPLETION. THE LIMITATIONS ON AUTHORITY AND RESPONSIBILITY OF THE ENGINEER SHALL ALSO APPLY TO THE ENGINEER'S CONSULTANTS, RESIDENT ENGINEER AND ASSISTANTS.
- THE CONTRACTOR MAY OBTAIN MUNICIPAL WATER IN BULK, AT NO CHARGE, AS LONG AS THERE IS NOT A "WATERING BAN" IN EFFECT. WATER CAN ONLY BE OBTAINED FROM THE WESTERN SPRINGS PUBLIC WORKS FACILITY 1440 HILLGROVE AVENUE. CONTACT PW SUPT. AT 708-246-1800 X207 ONE DAY PRIOR THE INDISCRIMINATE USE OF FIRE HYDRANTS IS STRICTLY PROHIBITED. WATER FOR CONSTRUCTION SHALL BE METERED OR OTHERWISE ACCOUNTED FOR AND A DAILY LOG MAINTAINED. THE CONTRACTOR SHALL PROVIDE THE WATER TRUCK AND DRIVER REQUIRED TO OBTAIN AND TRANSPORT THIS WATER. THE VILLAGE RESERVES THE RIGHT TO RESTRICT OR REFUSE THE USE OF VILLAGE WATER IF DEEMED NECESSARY.
- ACCESS TO PRIVATE DRIVEWAYS SHALL BE PROVIDED AT ALL TIMES EXCEPT DURING ACTUAL CONSTRUCTION ADJACENT THERE TO. AGGREGATE SURFACE COURSE FOR TEMPORARY ACCESS SHALL BE USED AS NEEDED, UTILIZING CRUSHED STONE OR CRUSHED GRAVEL. CONTRACTOR SHALL ALSO PROVIDE AGGREGATE SURFACE COURSE FOR TEMPORARY ACCESS AT SIDEWALK RAMPS AS NEEDED.
- IT WILL BE THE CONTRACTOR'S RESPONSIBILITY TO NOTIFY THE ENGINEER, RESIDENTS AND THE VILLAGE WHEN ACCESS TO DRIVEWAYS WILL BE TEMPORARILY CLOSED DUE TO CURB AND GUTTER AND/OR DRIVEWAY REPLACEMENT. THE CONTRACTOR SHALL DISTRIBUTE NOTICES PROVIDED BY THE VILLAGE TO RESIDENTS AT LEAST 24 HOURS PRIOR TO PLANNED CLOSURE. EVERY EFFORT SHALL BE MADE TO ACCOMMODATE ACCESS TO THESE PROPERTIES INCLUDING KNOCKING ON DOORS WHEN DRIVEWAYS ARE ABOUT TO BE CLOSED.
- ALL FRAME AND LID CASTINGS LOCATED WITHIN THE PAVEMENT WHICH REQUIRE RESETTING TO FINISH GRADE SHALL BE BACKFILLED WITH CLASS SI CONCRETE MEETING SECT. 1020 OF THE STANDARD SPECIFICATIONS. CLASS PP CONCRETE SHALL BE USED IF PLACEMENT OF SURFACE COURSE IS PLANNED IN LESS THAN 72 HOURS. HMA MATERIALS WILL NOT BE ALLOWED AS BACKFILL AROUND AN ADJUSTED CASTING. THIS WORK SHALL APPLY TO ALL CASTINGS ADJUSTED OR RECONSTRUCTED AS PART OF THIS CONTRACT. STRUCTURES SHALL BE ADJUSTED IN ACCORDANCE WITH THE IDOT DETAIL "DETAILS FOR FRAMES AND LIDS ADJUSTMENT WITH MILLING".
- THE TOP OF ALL NEW CURB BOXES ON DRAINAGE STRUCTURES SHALL BE STAMPED "DUMP NO WASTE - DRAINS TO RIVER".
- THE CONTRACTOR WILL BE REQUIRED TO USE A STEEL PLATE OR PLATES TO CLOSE ANY GAPS OCCURRING WHEN A FRAME IS OFFSET FROM THE STRUCTURE. THE STEEL PLATE SHALL BE 1/2 INCH THICK AND APPROXIMATELY 6-INCH WIDE BY 24-INCH LONG. SOME ADJUSTMENT IN SIZE MAY BE NECESSARY TO PREVENT THE STEEL PLATE FROM OVERHANGING THE OUTSIDE OF THE STRUCTURE WALL. THE STEEL PLATE SHALL BE BEDDED IN AND COVERED WITH MORTAR.
- NO OPEN TRENCH OR PIT SHALL REMAIN UNPROTECTED. IT IS THE CONTRACTOR'S RESPONSIBILITY TO BACKFILL THE TRENCH AND/OR PIT OR ERECT A STABLE AND SECURE SIX (6) FOOT HIGH CHAIN LINK FENCE AROUND THE PERIMETER OF EXCAVATION, ALONG WITH A STEEL PLATE OVER THE EXCAVATION TO PREVENT ANY ACCESS TO THE EXCAVATION WITHOUT THE CONTRACTOR'S PERMISSION. ALL EXCESS EXCAVATED MATERIAL AND DELIVERED MATERIAL FROM THE INSTALLATION OF UTILITIES AND/OR ROAD SHALL BE REMOVED AND DISPOSED OF OFF-SITE THE SAME DAY. CONTRACTOR IS NOT ALLOWED TO STOCKPILE MORE THAN 5 CUBIC YARDS OF MATERIAL OVERNIGHT. IF ANY MATERIAL STOCKPILES WILL REMAIN OVERNIGHT HIGHER THAN TWO (2) FEET, IT IS THE CONTRACTOR'S RESPONSIBILITY TO ERECT A STABLE AND SECURE SIX (6) FOOT HIGH CHAIN LINK FENCE AROUND THE PERIMETER OF THE STOCKPILED MATERIAL. THESE FENCES SHALL BE INSTALLED AND GATE/S LOCKED AT ALL TIMES EXCEPT WHEN ACCESS BY THE CONTRACTOR IS REQUIRED.

- ALL POSTS, RAILROAD TIES, DECORATIVE TIMBER AND OTHER PRIVATE AMENITIES IN CONFLICT WITH THE PROPOSED IMPROVEMENTS SHALL BE REMOVED AND RELOCATED AS DETERMINED BY THE ENGINEER AT THE TIME OF CONSTRUCTION. EVERY EFFORT SHALL BE MADE BY THE CONTRACTOR WHEN REMOVING THESE ITEMS TO PRESERVE THEM FROM HARM. ITEMS NOT RELOCATED SHALL BE PROPERLY DISPOSED OF BY THE CONTRACTOR.
- PRIOR TO CONSTRUCTION OF ANY PROPOSED UTILITIES, THE CONTRACTOR SHALL EXCAVATE AND LOCATE THE EXISTING UTILITIES TO VERIFY THEIR LOCATION, SIZE, AND DEPTH TO ENSURE THAT GRADE CONFLICTS WILL NOT OCCUR.
- A PORTABLE BATHROOM(S) SHALL BE PLACED ON THE JOB SITE AND RELOCATED WHEN NECESSARY SO IT IS ACCESSIBLE TO WORKERS. LOCATIONS NEAR PARKS SHOULD BE PRIORITIZED, COORDINATE LOCATION WITH THE VILLAGE.
- DURING CONSTRUCTION, THE CONTRACTOR WILL BE PERMITTED TO LIMIT ON-STREET PARKING IN ORDER TO COMPLETE CONSTRUCTION OPERATIONS. THE CONTRACTOR WILL BE REQUIRED TO COORDINATE WITH THE MUNICIPALITY A MINIMUM OF 48 HOURS IN ADVANCE. IT WILL BE THE RESPONSIBILITY OF THE CONTRACTOR TO PLACE ADVANCE SIGNS TO ALERT RESIDENTS AND COMMUTERS OF THE CONSTRUCTION WORK. THE PLACEMENT OF THESE SIGNS SHALL TAKE PLACE 48 HOURS IN ADVANCE IN ORDER TO ALLOW SUFFICIENT TIME FOR RESIDENTS AND GENERAL PUBLIC TO REVISE THEIR PARKING PATTERNS.
- CONTRACTOR SHALL TAKE PRECAUTION BY PRESERVING EXISTING TREES WITHIN THE RIGHT OF WAY. IF ANY DAMAGE OCCURS, TREES SHALL BE REPLACED IN KIND PER ARTICLE 201.07 REPAIR OR REPLACEMENT OF EXISTING PLANT MATERIAL REQUIREMENTS STATED HEREIN.
- ALL NITROGEN, PHOSPHORUS AND POTASSIUM FERTILIZER NUTRIENTS HAVE BEEN INTENTIONALLY OMITTED FROM THE CONTRACT ON THE SODDING APPLICATION.
- TREES LOCATED ALONG THE PARKWAY (ROW) ARE VILLAGE OWNED TREES. IF QUESTIONS DEVELOP DURING CONSTRUCTION REGARDING VILLAGE TREES, CONTACT VILLAGE'S FORESTER AT 708-246-1800, EXT. 200. THE CONTRACTOR MUST NOT STORE ANY EQUIPMENT, EXCAVATIONS OR MATERIALS WITHIN THE DRIP LINE OF PARKWAY TREES.
- NO EQUIPMENT STORAGE ON STREET OVERNIGHT. EQUIPMENT STORAGE AT VILLAGE PUBLIC WORKS FACILITY IS ALLOWED. CONTRACTOR TO COORDINATE WITH PUBLIC WORKS SUPT. CONTRACTOR SHALL UTILIZE THE WEST END OF THE PROJECT LIMITS FOR MATERIAL STORAGE (TRAFFIC CONTROL SIGNS, ETC.).
- DISPOSAL OF OLD FRAME AND GRATES/LIDS SHALL BE COORDINATED IN THE FIELD WITH THE ENGINEER. SOME FRAME AND GRATE/LIDS CAN BE SALVAGED AND DELIVERED TO PUBLIC WORKS BY THE CONTRACTOR.
- AFTER HOT MIX ASPHALT SURFACE REMOVAL 3 1/4" AND PRIOR TO HMA SURFACE INSTALLATION, CONTRACTOR SHALL REMOVE ANY STANDING WATER IN PAVEMENT WITHIN 24 HOURS OF RAINFALL.
- IT IS THE CONTRACTOR'S SOLE RESPONSIBILITY TO COORDINATE WITH THE BNSF RAILROAD WHENEVER CONSTRUCTION ACTIVITY IS WITHIN 25 FEET OF THE RAILROAD ROW. THE CONTRACTOR SHALL RETAIN FLAGMAN EMPLOYED AND DESIGNATED BY THE BNSF RAILROAD TO MONITOR ONCOMING TRAIN TRAFFIC AND ADVISE CONTRACTOR PERSONNEL WHEN ACTIVITY ON OR NEAR THE RAILROAD RIGHT-OF-WAY MAY PROCEED. THIS ITEM WILL BE PAID FOR ACCORDING TO ARTICLE 107.12 AND WILL BE REIMBURSED ACCORDING TO ARTICLE 109.05.
- IF RAILROAD FLAGGER WAS RESERVED AND THE CONTRACTOR DOES NOT USE OR CANCEL THE RESERVATION AT LEAST 24 HOURS IN ADVANCE; THE CONTRACTOR SHALL BE RESPONSIBLE FOR THE SERVICE FEE.
- CONTRACTOR SHALL TAKE THE CONTRACTOR ORIENTATION COURSE AT WWW.BNSFCONTRACTOR.COM AND TAKE THE BNSF EXAM. ALL WORKERS ON OR INSIDE RAILROAD ROW SHALL TAKE THE EXAM. E-RAILSAFE ID BADGES SHALL BE WORN AT ALL TIMES WHILE INSIDE THE RAILROAD ROW.
- CONTRACTORS SHALL BE CONFINED IN DESIGNATED AREAS AND SHALL NOT INTERFERE WITH TRAIN OPERATIONS OR COMMUTER'S PEDESTRIAN PATHS.

**INDEX OF SHEETS**

1	COVER
2	INDEX OF SHEETS, HIGHWAY STANDARDS, AND GENERAL NOTES
3 - 7	SUMMARY OF QUANTITIES
8 - 9	TYPICAL SECTIONS AND HOT MIX ASPHALT SURFACE REQUIREMENTS
10 - 11	ROADWAY PLAN
12 - 13	MISCELLANEOUS DETAILS
14	FRAMES AND LIDS TO BE ADJUSTED (BD08)
15	PAVEMENT PATCHING FOR HMA SURFACED PAVEMENT (BD22)
16	BUTT JOINT AND HMA TAPER DETAILS (BD32)
17	TRAFFIC CONTROL & PROTECTION FOR SIDE ROADS, INTERSECTIONS & DRIVEWAYS (TC10)
18	DISTRICT ONE TYPICAL PAVEMENT MARKINGS (TC-13)
19	SHORT TERM PAVEMENT MARKING LETTERS AND SYMBOLS (TC-16)
20	DRIVEWAY ENTRANCE SIGNING (TC-26)

**HIGHWAY STANDARDS**

000001-08	STANDARD SYMBOLS, ABBREVIATIONS AND PATTERNS
424001-11	PERPENDICULAR CURB RAMPS FOR SIDEWALKS
424021-06	DEPRESSED CORNER FOR SIDEWALKS
442201-03	CLASS C AND D PATCHES
604001-05	FRAME AND LIDS TYPE 1
604051-04	FRAME AND GRATE TYPE 11
606001-08	CONCRETE CURB TYPE B AND COMBINATION CONCRETE CURB AND GUTTER
701006-05	OFF-RD OPERATIONS, 2L, 2W, 15' (4.5 m) TO 24" (600 mm) FROM PAVEMENT
701011-04	OFF-RD MOVING OPERATIONS, 2L, 2W, DAY ONLY
701301-04	LANE CLOSURE, 2L, 2W, SHORT TIME OPERATIONS
701311-03	LANE CLOSURE 2L, 2W MOVING OPERATIONS - DAY ONLY
701501-06	URBAN LANE CLOSURE, 2L, 2W, UNDIVIDED
701701-10	URBAN LANE CLOSURE, MULTILANE INTERSECTION
701801-06	SIDEWALK, CORNER OR CROSSWALK CLOSURE
701901-09	TRAFFIC CONTROL DEVICES
780001-05	TYPICAL PAVEMENT MARKINGS

**COMMITMENTS**

THERE ARE NO COMMITMENTS ON THIS PROJECT.

**DISTRICT ONE DETAILS**

BD-08	FRAMES AND LIDS TO BE ADJUSTED (BD08)
BD-22	PAVEMENT PATCHING FOR HMA SURFACED PAVEMENT (BD22)
BD-32	BUTT JOINT AND HMA TAPER DETAILS (BD32)
TC-10	TRAFFIC CONTROL & PROTECTION FOR SIDE ROADS, INTERSECTIONS & DRIVEWAYS (TC10)
TC-13	DISTRICT ONE TYPICAL PAVEMENT MARKINGS (TC-13)
TC-16	SHORT TERM PAVEMENT MARKING LETTERS AND SYMBOLS
TC-26	DRIVEWAY ENTRANCE SIGNING

STATE OF ILLINOIS - PROFESSIONAL DESIGN FIRM  
 LICENSE NO. - 118-001121 - EXPIRES 4/30/2025  
 SHYDER CONSULTANTS  
 9/9/2024  
 8:53:00 AM  
 P:\SPR\2325873-Burlington Ave STP DICAD06\_Microstation\Sheets\2325873\_SHT-GenNotes.dgn  
 ...:\pic\dvd\p\df\BW\_Default.plt  
 ...:\pics\2325873\_Pen-Ph2.tbl  
 P:\SPR\2325873-Burlington Ave STP DICAD06\_Microstation\Sheets\2325873\_SHT-GenNotes.dgn



USER NAME = shyder	DESIGNED - SH	REVISED -
	DRAWN - KAR	REVISED -
PLOT SCALE = 40,0000 ' / in.	CHECKED - JBT	REVISED -
PLOT DATE = 9/9/2024	DATE - 06-10-2024	FILE - 2325873_SHT-GenNotes.dgn

STATE OF ILLINOIS  
DEPARTMENT OF TRANSPORTATION

**INDEX OF SHEETS AND HIGHWAY STANDARDS**

SCALE: NONE SHEET 1 OF 1 SHEETS STA. TO STA.

F.A.U. RTE.	SECTION	COUNTY	TOTAL SHEETS	SHEET NO.
3783	23-00104-00-R5	COOK	20	2
CONTRACT NO. 61K56				
ILLINOIS FED. AID PROJECT 11R(01610)				

**SUMMARY OF QUANTITIES**

CODE NO.	ITEM	UNIT	TOTAL QUANTITY	CONSTRUCTION CODE
				80% STU 20% Village
				Roadway
				0005
				Urban
25200200	SUPPLEMENTAL WATERING	UNIT	20	20
20200100	EARTH EXCAVATION	CU YD	10	10
20201200	REMOVAL AND DISPOSAL OF UNSUITABLE MATERIAL	CU YD	32	32
21001000	GEO TECHNICAL FABRIC FOR GROUND STABILIZATION	SQ YD	96	96
21101615	TOPSOIL FURNISH AND PLACE, 4"	SQ YD	369	369
25200100	SODDING	SQ YD	369	369
28000510	INLET FILTERS	EACH	19	19
30300001	AGGREGATE SUBGRADE IMPROVEMENT	CU YD	32	32
30300112	AGGREGATE SUBGRADE IMPROVEMENT 12"	SQ YD	96	96
35101600	AGGREGATE BASE COURSE, TYPE B 4"	SQ YD	479	479
35101800	AGGREGATE BASE COURSE, TYPE B 6"	SQ YD	97	97
40600290	BITUMINOUS MATERIALS (TACK COAT)	POUND	6,052	6,052
40600370	LONGITUDINAL JOINT SEALANT	FOOT	2,795	2,795
40600400	MIXTURE FOR CRACKS, JOINTS, AND FLANGEWAYS	TON	16	16
40600982	HOT-MIX ASPHALT SURFACE REMOVAL - BUTT JOINT	SQ YD	101	101

\* SPECIALTY ITEM

STATE OF ILLINOIS - PROFESSIONAL DESIGN FIRM  
 LICENSE NO. - 184-001121 - EXPIRES 4/30/2025  
 9/4/2024  
 ...\\plotdir\pdf-bw\_Default.plt  
 ...\\plots\2325873\_Per-PH2.tbl  
 P:\WSPRVA\2325873-Burlington Ave STP DICAD\06\_Microstation\Sheets\2325873\_SHT-SOQ.dgn



USER NAME = shyder	DESIGNED - SH	REVISED -
PLOT SCALE = 40.0000' / in.	DRAWN - KAR	REVISED -
PLOT DATE = 9/4/2024	CHECKED - JBT	REVISED -
	DATE - 06-10-2024	FILE - 2325873_SHT-SOQ.dgn

STATE OF ILLINOIS  
DEPARTMENT OF TRANSPORTATION

**SUMMARY OF QUANTITIES**

SCALE: NONE | SHEET 1 OF 5 SHEETS | STA. TO STA.

F.A.U. RTE.	SECTION	COUNTY	TOTAL SHEETS	SHEET NO.
3783	23-00104-00-RS	COOK	20	3
CONTRACT NO. 61K56			ILLINOIS FED. AID PROJECT 11R016101	

**SUMMARY OF QUANTITIES**

CODE NO.	ITEM	UNIT	TOTAL QUANTITY	CONSTRUCTION CODE	
				80% STU	20% Village
				Roadway	
				0005	
				Urban	
40603020	HOT-MIX ASPHALT BINDER COURSE, IL-9.5, N50	TON	904		904
40604060	HOT-MIX ASPHALT SURFACE COURSE, IL-9.5, MIX "D", N50	TON	904		904
42400800	REFLECTIVE WARNING	SQ FT	110		110
44000162	HOT-MIX ASPHALT SURFACE REMOVAL, 3 1/4"	SQ YD	8,965		8,965
44000200	DRIVEWAY PAVEMENT REMOVAL	SQ YD	30		30
44000500	COMBINATION CURB AND GUTTER REMOVAL	FOOT	981		981
44000600	SIDEWALK REMOVAL	SQ FT	2,836		2,836
44201717	CLASS D PATCHES, TYPE II, 6 INCH	SQ YD	55		55
44201721	CLASS D PATCHES, TYPE III, 6 INCH	SQ YD	118		118
44201723	CLASS D PATCHES, TYPE IV, 6 INCH	SQ YD	305		305
48301000	PROTECTIVE COAT	SQ YD	479		479
60202405	CATCH BASINS, TYPE A, 4'-DIAMETER	EACH	1		1
60220200	MANHOLES, TYPE A, 4'-DIAMETER	EACH	1		1
60230800	INLETS, TYPE A	EACH	1		1
60404800	FRAMES AND GRATES, TYPE 11	EACH	1		1

\* SPECIALTY ITEM

STATE OF ILLINOIS - PROFESSIONAL DESIGN FIRM  
 LICENSE NO. - 184-001121 - EXPIRES 4/30/2025  
 SHYDER 9/19/2024 8:22:50 AM  
 FILE NAME: P:\WSPRV\2325873-Burlington Ave STP DICAD\06\_Microstation\Sheets\2325873\_SHT-SOQ.dgn



USER NAME = shyder	DESIGNED - SH	REVISED -
DRAWN - KAR	CHECKED - JBT	REVISED -
PLOT SCALE = 40,0000' / in.	DATE - 06-10-2024	FILE - 2325873_SHT-SOQ.dgn
PLOT DATE = 9/19/2024		

STATE OF ILLINOIS  
 DEPARTMENT OF TRANSPORTATION

SUMMARY OF QUANTITIES	
SCALE: NONE	SHEET 2 OF 5 SHEETS STA. TO STA.

F.A.U. RTE.	SECTION	COUNTY	TOTAL SHEETS	SHEET NO.
3783	23-00104-00-RS	COOK	20	4
CONTRACT NO. 61K56				
ILLINOIS FED. AID PROJECT 11R016101				

**SUMMARY OF QUANTITIES**

CODE NO	ITEM	UNIT	TOTAL QUANTITY	CONSTRUCTION CODE	
				80% STU 20% Village	Roadway 0005 Urban
60406000	FRAMES AND LIDS, TYPE 1, OPEN LID	EACH	1	1	
60406100	FRAMES AND LIDS, TYPE 1, CLOSED LID	EACH	6	6	
60500040	REMOVING MANHOLES	EACH	1	1	
60500050	REMOVING CATCH BASINS	EACH	1	1	
60500060	REMOVING INLETS	EACH	1	1	
* 66900200	NON-SPECIAL WASTE DISPOSAL	CU YD	42	42	
* 66900530	SOIL DISPOSAL ANALYSIS	EACH	1	1	
* 66901001	REGULATED SUBSTANCES PRE-CONSTRUCTION PLAN	L SUM	1	1	
* 66901003	REGULATED SUBSTANCES FINAL CONSTRUCTION REPORT	L SUM	1	1	
* 66901006	REGULATED SUBSTANCES MONITORING	CAL DA	5	5	
67100100	MOBILIZATION	L SUM	1	1	
70102620	TRAFFIC CONTROL AND PROTECTION, STANDARD 701501	L SUM	1	1	
70102635	TRAFFIC CONTROL AND PROTECTION, STANDARD 701701	L SUM	1	1	
70102640	TRAFFIC CONTROL AND PROTECTION, STANDARD 701801	L SUM	1	1	
70107025	CHANGEABLE MESSAGE SIGN	CAL DA	248	248	

\* SPECIALTY ITEM

STATE OF ILLINOIS - PROFESSIONAL DESIGN FIRM  
 LICENSE NO. - 184-001121 - EXPIRES 4/30/2025  
 9/4/2024 12:19:22 PM  
 MODEL: Default  
 FILE NAME: P:\WS\PRV\2325873\Burlington Ave STP DICAD\06\_Microstation\Sheets\2325873\_SHT-SOQ.dgn

	USER NAME = shyder	DESIGNED - SH	REVISED -	STATE OF ILLINOIS DEPARTMENT OF TRANSPORTATION	SUMMARY OF QUANTITIES			F.A.U RTE.	SECTION	COUNTY	TOTAL SHEETS	SHEET NO.
	PLOT SCALE = 40.0000' / in.	DRAWN - KAR	REVISED -					3783	23-00104-00-RS	COOK	20	5
PLOT DATE = 9/4/2024	CHECKED - JBT	REVISED -	FILE - 2325873_SHT-SOQ.dgn		SCALE: NONE	SHEET 3 OF 5 SHEETS	STA.	TO STA.	CONTRACT NO. 61K56			
	DATE - 06-10-2024	FILE - 2325873_SHT-SOQ.dgn							ILLINOIS FED. AID PROJECT 11R0101			

**SUMMARY OF QUANTITIES**

CODE NO.	ITEM	UNIT	TOTAL QUANTITY	CONSTRUCTION CODE	
				80% STU	20% Village
				0905	Urban
70300100	SHORT TERM PAVEMENT MARKING	FOOT	7,192	7,192	
70300150	SHORT TERM PAVEMENT MARKING REMOVAL	SQ FT	2,781	2,781	
72000100	SIGN PANEL - TYPE 1	SQ FT	28	28	
72400100	REMOVE SIGN PANEL ASSEMBLY - TYPE A	EACH	3	3	
72800100	TELESCOPING STEEL SIGN SUPPORT	FOOT	72	72	
78000100	THERMOPLASTIC PAVEMENT MARKING - LETTERS AND SYMBOLS	SQ FT	25	25	
78000200	THERMOPLASTIC PAVEMENT MARKING - LINE 4"	FOOT	3,481	3,481	
78000400	THERMOPLASTIC PAVEMENT MARKING - LINE 6"	FOOT	15	15	
78000600	THERMOPLASTIC PAVEMENT MARKING - LINE 12"	FOOT	552	552	
78000650	THERMOPLASTIC PAVEMENT MARKING - LINE 24"	FOOT	115	115	
78009000	MODIFIED URETHANE PAVEMENT MARKING - LETTERS AND SYMBOLS	SQ FT	4	4	
78009004	MODIFIED URETHANE PAVEMENT MARKING - LINE 4"	FOOT	300	300	
78300202	PAVEMENT MARKING REMOVAL - WATER BLASTING	SQ FT	20	20	
XX002949	TEMPORARY ACCESS WALK	EACH	16	16	
XX003313	REMOVE AND REINSTALL BRICK PAVER	SQ FT	260	260	

\* SPECIALTY ITEM

STATE OF ILLINOIS - PROFESSIONAL DESIGN FIRM  
 LICENSE NO. - 184-001121 - EXPIRES 4/30/2025  
 9/4/2024 12:19:23 PM  
 ...\\plotdrv\pdf-BW\_Default.plt  
 ...\\plots\2325873\_Pen-PH2.tbl  
 P:\WSPRV\2325873-Burlington Ave STP D\CAD\06\_Microstation\Sheets\2325873\_SHT-SOQ.dgn  
 MODEL: D:\dwg.dwg  
 PLOT DATE: 9/4/2024



USER NAME = shyder	DESIGNED - SH	REVISED -
PLOT SCALE = 40,0000' / in.	DRAWN - KAR	REVISED -
PLOT DATE = 9/4/2024	CHECKED - JBT	REVISED -
	DATE - 06-10-2024	FILE - 2325873_SHT-SOQ.dgn

STATE OF ILLINOIS  
DEPARTMENT OF TRANSPORTATION

**SUMMARY OF QUANTITIES**

SCALE: NONE SHEET 4 OF 5 SHEETS STA. TO STA.

F.A.U. RTE.	SECTION	COUNTY	TOTAL SHEETS	SHEET NO.
3783	23-00104-00-RS	COOK	20	6
			CONTRACT NO. 61K56	
ILLINOIS FED. AID PROJECT 11R(610)				



STATE OF ILLINOIS - PROFESSIONAL DESIGN FIRM  
 LICENSE NO. - 184-001121 - EXPIRES 4/30/2025  
 SHYDER CONSULTING ENGINEERS  
 9/4/2024  
 FILE NAME: P:\SPR\2325873-Burlington Ave STP D\CAD\06\_Microstation\Sheets\2325873\_SHT-Typical Section.dgn  
 ...:\pic\dvd\p\d\B\W\_Default.plt  
 ...:\pics\2325873\_Pen-PH2.tbl  
 P:\SPR\2325873-Burlington Ave STP D\CAD\06\_Microstation\Sheets\2325873\_SHT-Typical Section.dgn

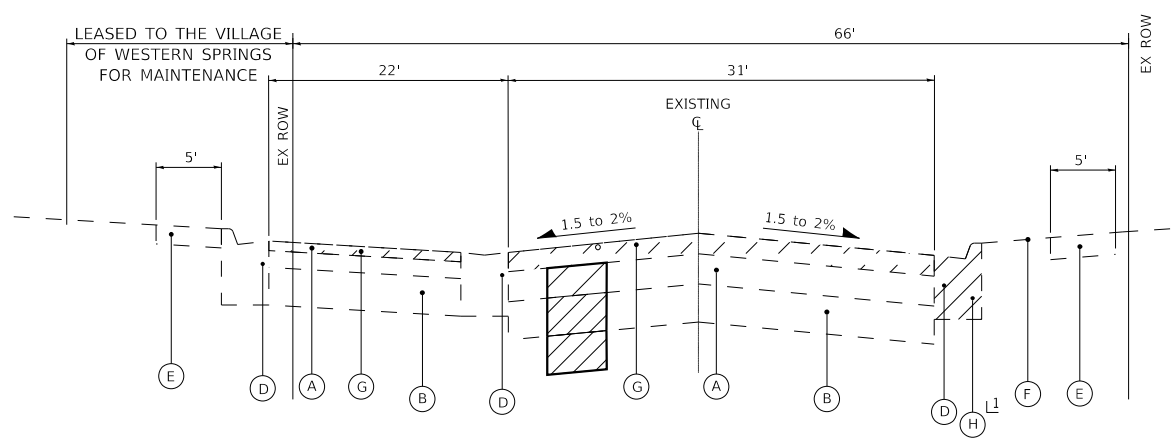

**EXISTING TYPICAL SECTION**

BURLINGTON AVE  
CENTRAL AVE TO GRAND AVE  
LOCATIONS DETERMINED BY ENGINEER

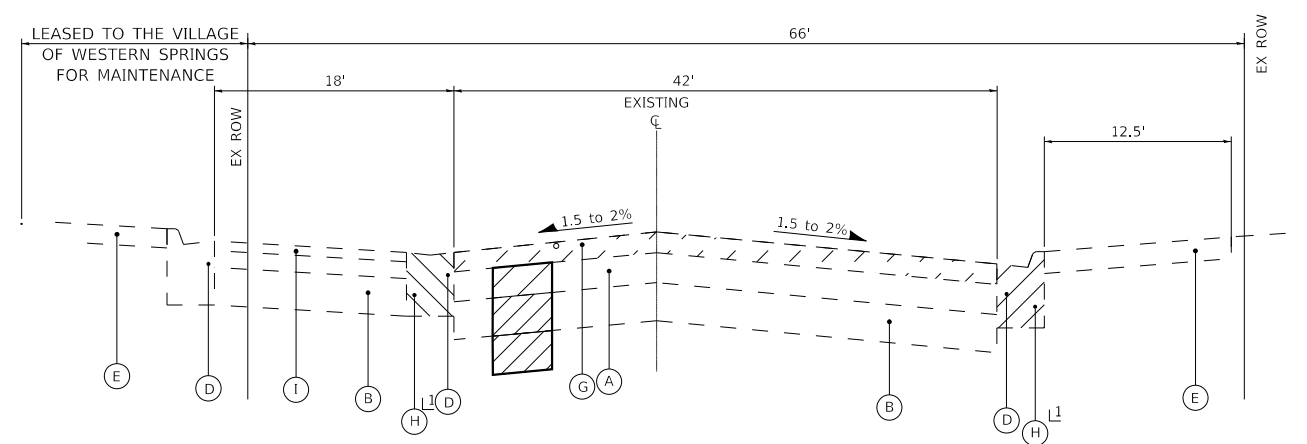

**EXISTING TYPICAL SECTION**

BURLINGTON AVE  
GRAND AVE TO LAWN AVE  
LOCATIONS DETERMINED BY ENGINEER

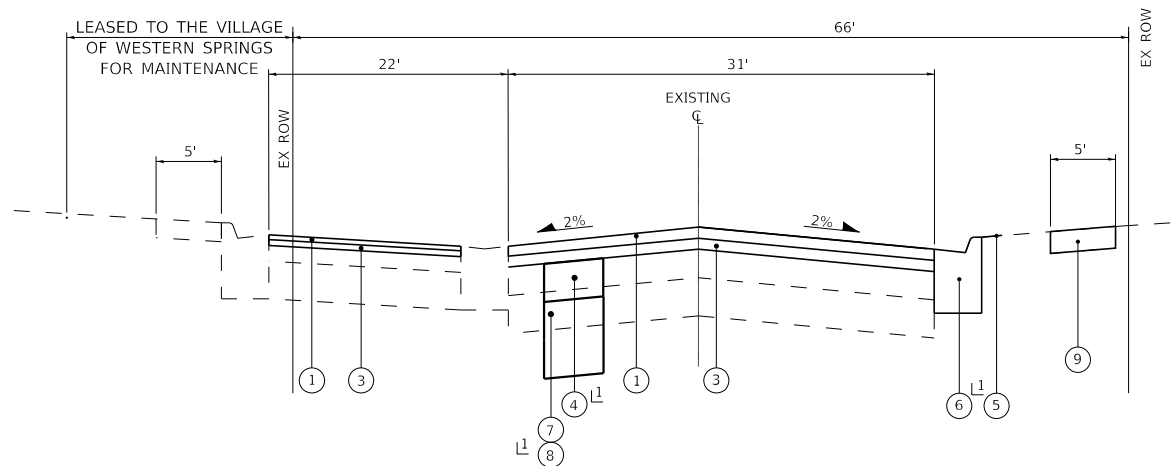

**PROPOSED TYPICAL SECTION**

BURLINGTON AVE  
CENTRAL AVE TO GRAND AVE  
LOCATIONS DETERMINED BY ENGINEER

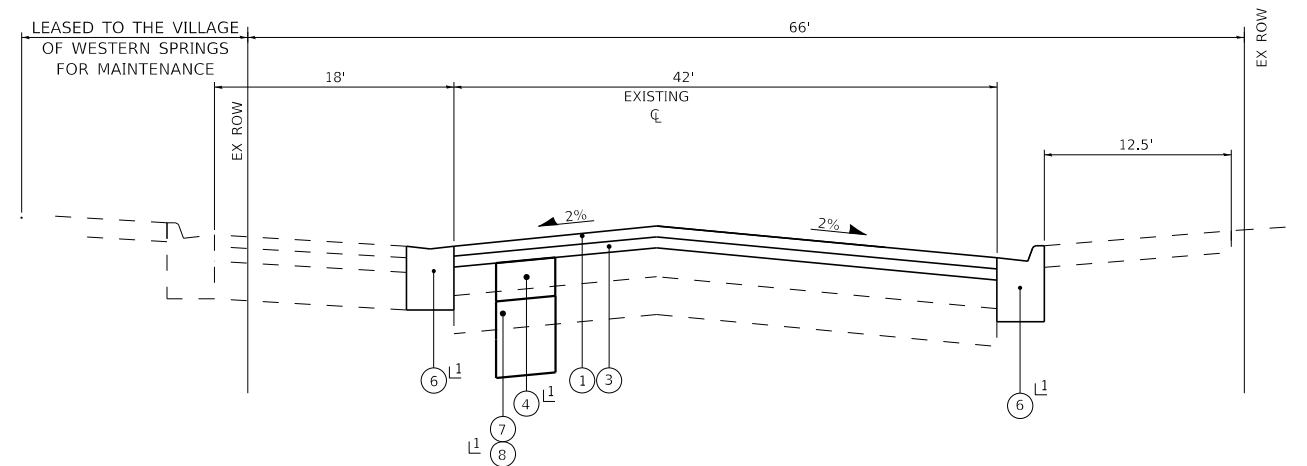

**PROPOSED TYPICAL SECTION**

BURLINGTON AVE  
GRAND AVE TO LAWN AVE  
LOCATIONS DETERMINED BY ENGINEER

NOTE:  
 GEOTECHNICAL FABRIC FOR GROUND STABILIZATION AND/OR AGGREGATE SUBGRADE IMPROVEMENT (CU YD) HAVE BEEN PROVIDED FOR USE AT THE LOCATIONS INDICATED FOR SOILS THAT TEND TO BE UNSTABLE AND/OR UNSUITABLE. THE ACTUAL NEED FOR REMOVAL AND REPLACEMENT WITH ABOVE ITEM WILL BE DETERMINED IN THE FIELD AT THE TIME OF CONSTRUCTION BY THE GEOTECHNICAL ENGINEER. ALL POTENTIALLY UNSTABLE SOILS SHOULD BE TESTED WITH A STATIC OR DYNAMIC CONE PENETROMETER AND TREATED IN ACCORDANCE WITH ARTICLE 301.04 OF THE STANDARD SPECIFICATIONS AND IDOT SUBGRADE STABILITY MANUAL. IF UNSTABLE AND/OR UNSUITABLE SOILS ARE NOT ENCOUNTERED, THEN THE QUANTITY SHALL BE DEDUCTED AND NO ADDITIONAL COMPENSATION WILL BE DUE TO THE CONTRACTOR.

THE AGGREGATE GRADATION FOR THE AGGREGATE SUBGRADE IMPROVEMENT 12" LOWER LIFT SHALL BE CS 1 OR RR 1.

MIXTURE TYPE	AIR VOIDS @ Ndes	QMP
<b>PAVEMENT RESURFACING</b>		
HOT-MIX ASPHALT SURFACE COURSE, IL-9.5, MIX "D", N50 - 1.75"	4% @ 50 Gyr.	LR1030-2
HOT-MIX ASPHALT BINDER COURSE, IL-9.5, N50 - 1.75"	4% @ 50 Gyr.	LR1030-2
<b>HMA DRIVEWAY REMOVAL &amp; REPLACEMENT</b>		
HOT-MIX ASPHALT SURFACE COURSE, IL-9.5, MIX "D", N50; 2"	4% @ 50 Gyr.	LR1030-2
HOT-MIX ASPHALT BINDER COURSE, IL-19.0, N50 - 4"	4% @ 50 Gyr.	LR1030-2
<b>PATCHING</b>		
CLASS D PATCHES (HMA BINDER IL-19.0mm); 6"	4% @ 70 Gyr.	LR1030-2
QMP DESIGNATION: QUALITY CONTROL/QUALITY ASSURANCE (QC/QA) PER LR1030-2		

- NOTES:
- THE UNIT WEIGHT USED TO CALCULATE ALL HMA SURFACE MIXTURE QUANTITIES IS 112 LBS/SQ YD/IN.
  - THE "AC TYPE" FOR POLYMERIZED HMA MIXES SHALL BE "SBS/SBR PG 76 -22" AND FOR NON-POLYMERIZED HMA THE "AC TYPE" SHALL BE "PG 64 -22" UNLESS MODIFIED BY RECLAIMED MATERIALS SPECIFICATIONS.
  - THE LOGITUDINAL JOINT SEALANT SHALL BE PLACED ON HMA BC IL-9.5 N50

- EXISTING LEGEND**
- (A) EXISTING HMA BINDER & SURFACE COURSE  
CENTRAL AVE TO GRAND AVE = 8.75" AVG  
GRAND AVE TO WOLF RD = 7.5" AVG
  - (B) EXISTING BASE  
CENTRAL AVE TO GRAND AVE = 6" AVG STONE  
GRAND AVE TO WOLF RD = 7.5" AVG CONCRETE
  - (C) GROUND SURFACE
  - (D) EXISTING COMBINATION CURB AND GUTTER
  - (E) EXISTING SIDEWALK
  - (F) EXISTING DRIVEWAY
  - (G) HOT-MIX ASPHALT SURFACE REMOVAL, 3.25"
  - (H) REMOVE EXISTING COMBINATION CURB & GUTTER
  - (I) CONCRETE PAVEMENT
  - [X] REMOVAL ITEM

- PROPOSED LEGEND**
- (1) HOT-MIX ASPHALT SURFACE COURSE, MIX "D", IL9.5, N50 - 1.75"
  - (2) NOT USED
  - (3) HOT-MIX ASPHALT BINDER COURSE, IL-9.5, N50 - 1.75"
  - (4) CLASS D PATCHES 6"
  - (5) PARKWAY RESTORATION (SODDING)
  - (6) COMBINATION CONCRETE CURB AND GUTTER, TYPE B-6.12
  - (7) AGGREGATE SUBGRADE IMPROVEMENT 12" (SQ. YD.)
  - (8) REMOVAL AND DISPOSAL OF UNSUITABLE MATERIALS
  - (9) PORTLAND CEMENT CONCRETE SIDEWALK 5 INCH

**BAXTER & WOODMAN** Consulting Engineers

USER NAME = shyder	DESIGNED - SH	REVISED -
PLOT SCALE = 2,000' / in.	DRAWN - KAR	REVISED -
PLOT DATE = 9/4/2024	CHECKED - JBT	REVISED -
	DATE - 06-10-2024	FILE - 2325873_SHT-Typical Section.dgn

STATE OF ILLINOIS  
DEPARTMENT OF TRANSPORTATION

**TYPICAL SECTIONS AND  
HOT-MIX ASPHALT MIXTURE REQUIREMENTS**

SCALE: NONE SHEET 1 OF 2 SHEETS STA. TO STA.

F.A.U. RTE.	SECTION	COUNTY	TOTAL SHEETS	SHEET NO.
3783	23-00104-00-R5	COOK	20	8
CONTRACT NO. 61K56				
ILLINOIS FED. AID PROJECT 10R(610)				



STATE OF ILLINOIS - PROFESSIONAL DESIGN FIRM  
 LICENSE NO. - 184-001121 - EXPIRES 4/30/2025  
 SHYDER CONSULTING ENGINEERS  
 9/4/2024  
 FILE NAME: P:\WSPR\2325873-Burlington Ave STP D\CAD\06\_Microstation\Sheets\2325873\_SHT-Typical Section.dgn

...|p|c|d|r|v|p|d|f|B|W\_Default.plt  
 ...|p|c|s|2|3|2|5|8|7|3\_Pen-Ph2.tbl  
 P:\WSPR\2325873-Burlington Ave STP D\CAD\06\_Microstation\Sheets\2325873\_SHT-Typical Section.dgn

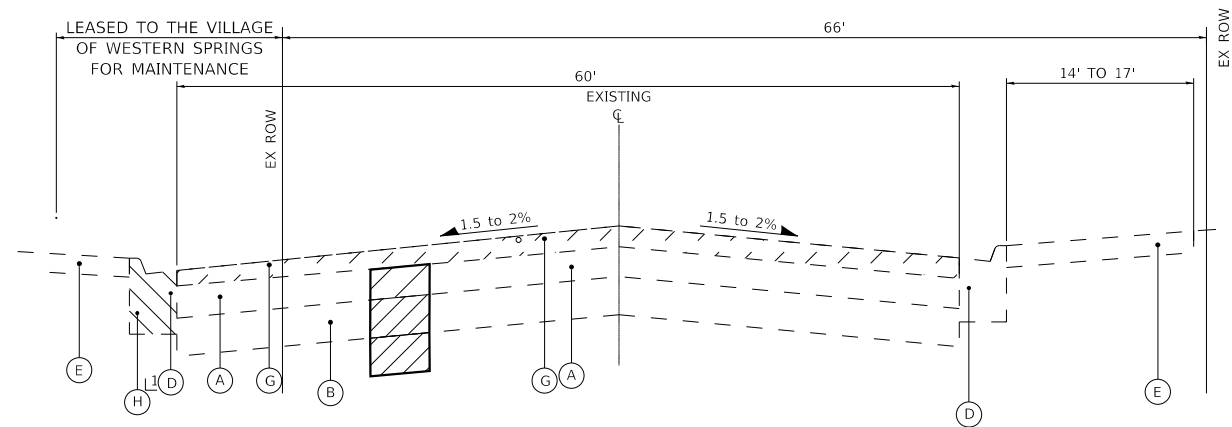

**EXISTING TYPICAL SECTION**

BURLINGTON AVE  
 LAWN AVE TO WOLF RD  
 1 LOCATIONS DETERMINED BY ENGINEER

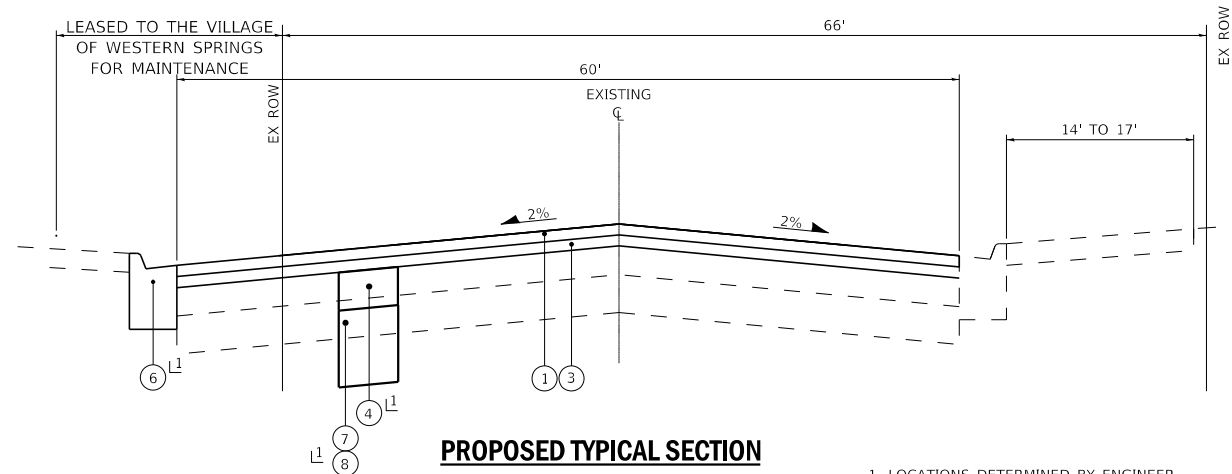

**PROPOSED TYPICAL SECTION**

BURLINGTON AVE  
 LAWN AVE TO WOLF RD  
 1 LOCATIONS DETERMINED BY ENGINEER

NOTE: THE LOGITUDINAL JOINT SEALANT SHALL BE PLACED ON HMA BC IL-9.5 N50

NOTE:  
 GEOTECHNICAL FABRIC FOR GROUND STABILIZATION AND/OR AGGREGATE SUBGRADE IMPROVEMENT (CU YD) HAVE BEEN PROVIDED FOR USE AT THE LOCATIONS INDICATED FOR SOILS THAT TEND TO BE UNSTABLE AND/OR UNSUITABLE. THE ACTUAL NEED FOR REMOVAL AND REPLACEMENT WITH ABOVE ITEM WILL BE DETERMINED IN THE FIELD AT THE TIME OF CONSTRUCTION BY THE GEOTECHNICAL ENGINEER. ALL POTENTIALLY UNSTABLE SOILS SHOULD BE TESTED WITH A STATIC OR DYNAMIC CONE PENETROMETER AND TREATED IN ACCORDANCE WITH ARTICLE 301.04 OF THE STANDARD SPECIFICATIONS AND IDOT SUBGRADE STABILITY MANUAL. IF UNSTABLE AND/OR UNSUITABLE SOILS ARE NOT ENCOUNTERED, THEN THE QUANTITY SHALL BE DEDUCTED AND NO ADDITIONAL COMPENSATION WILL BE DUE TO THE CONTRACTOR.

THE AGGREGATE GRADATION FOR THE AGGREGATE SUBGRADE IMPROVEMENT 12" LOWER LIFT SHALL BE CS 1 OR RR 1.

**EXISTING LEGEND**

- (A) EXISTING HMA BINDER & SURFACE COURSE  
CENTRAL AVE TO GRAND AVE = 8.75" AVG  
GRAND AVE TO WOLF RD = 7.5" AVG
- (B) EXISTING BASE  
CENTRAL AVE TO GRAND AVE = 6" AVG STONE  
GRAND AVE TO WOLF RD = 7.5" AVG CONCRETE
- (C) GROUND SURFACE
- (D) EXISTING COMBINATION CURB AND GUTTER
- (E) EXISTING SIDEWALK
- (F) EXISTING DRIVEWAY
- (G) HOT-MIX ASPHALT SURFACE REMOVAL, 3.25"
- (H) REMOVE EXISTING COMBINATION CURB & GUTTER
- ☐ REMOVAL ITEM

**PROPOSED LEGEND**

- ① HOT-MIX ASPHALT SURFACE COURSE, MIX "D", IL9.5, N50 - 1.75"
- ② NOT USED
- ③ HOT-MIX ASPHALT BINDER COURSE, IL-9.5, N50 - 1.75"
- ④ CLASS D PATCHES 6"
- ⑤ PARKWAY RESTORATION (SODDING)
- ⑥ COMBINATION CONCRETE CURB AND GUTTER, TYPE B-6.12
- ⑦ AGGREGATE SUBGRADE IMPROVEMENT 12" (SQ. YD.)
- ⑧ REMOVAL AND DISPOSAL OF UNSUITABLE MATERIALS
- ⑨ PORTLAND CEMENT CONCRETE SIDEWALK 5 INCH

	USER NAME = shyder	DESIGNED - SH	REVISED -
		DRAWN - KAR	REVISED -
	PLOT SCALE = 2,000' / in.	CHECKED - JBT	REVISED -
	PLOT DATE = 9/4/2024	DATE - 06-10-2024	FILE - 2325873_SHT-Typical Section.dgn

STATE OF ILLINOIS  
 DEPARTMENT OF TRANSPORTATION

**TYPICAL SECTIONS AND  
 HOT-MIX ASPHALT MIXTURE REQUIREMENTS**

SCALE: NONE SHEET 2 OF 2 SHEETS STA. TO STA.

F.A.U. RTE.	SECTION	COUNTY	TOTAL SHEETS	SHEET NO.
3783	23-00104-00-R5	COOK	20	9
CONTRACT NO. 61K56				

ILLINOIS FED. AID PROJECT 11R(610)

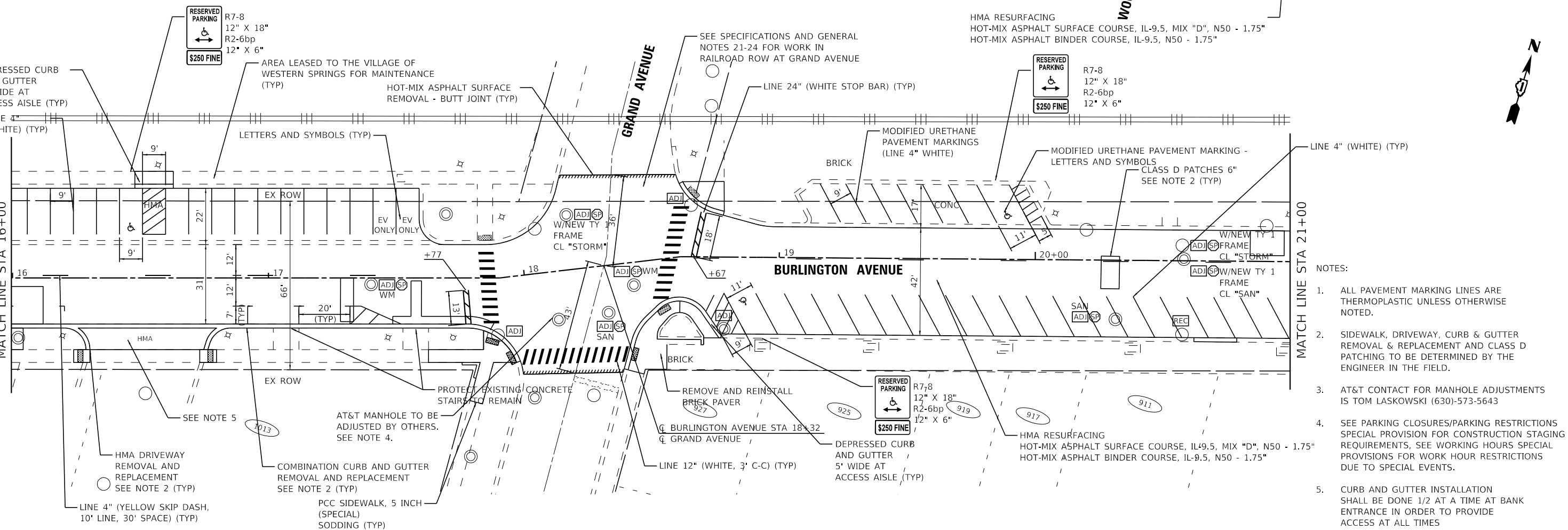
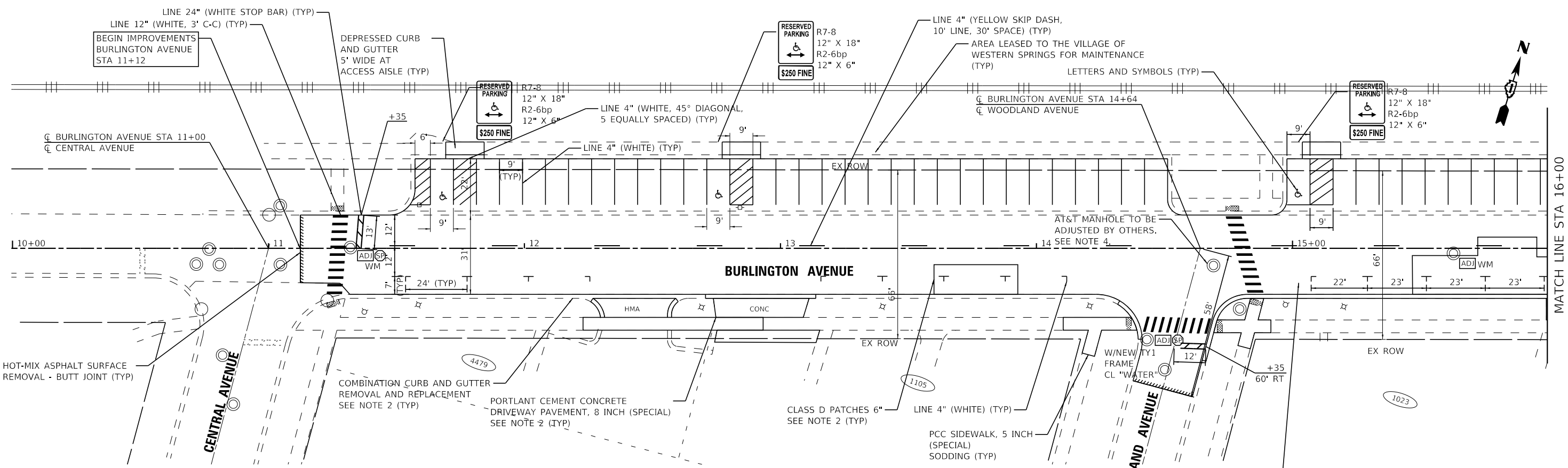

- NOTES:
1. ALL PAVEMENT MARKING LINES ARE THERMOPLASTIC UNLESS OTHERWISE NOTED.
  2. SIDEWALK, DRIVEWAY, CURB & GUTTER REMOVAL & REPLACEMENT AND CLASS D PATCHING TO BE DETERMINED BY THE ENGINEER IN THE FIELD.
  3. AT&T CONTACT FOR MANHOLE ADJUSTMENTS IS TOM LASKOWSKI (630)-573-5643
  4. SEE PARKING CLOSURES/PARKING RESTRICTIONS SPECIAL PROVISION FOR CONSTRUCTION STAGING REQUIREMENTS, SEE WORKING HOURS SPECIAL PROVISIONS FOR WORK HOUR RESTRICTIONS DUE TO SPECIAL EVENTS.
  5. CURB AND GUTTER INSTALLATION SHALL BE DONE 1/2 AT A TIME AT BANK ENTRANCE IN ORDER TO PROVIDE ACCESS AT ALL TIMES

STATE OF ILLINOIS - PROFESSIONAL DESIGN FIRM  
 LICENSE NO. - 184-001121 - EXPIRES 4/30/2025  
 SHYDER, JEFFREY  
 9/4/2024  
 FILE NAME: P:\SPR\2325873-Burlington Ave STP D\CAD\06\_Microstation\Sheets\2325873\_SHT-Plan1.dgn



USER NAME = shyder	DESIGNED - SH	REVISED -
	DRAWN - KAR	REVISED -
PLOT SCALE = 40,0000' / in.	CHECKED - JBT	REVISED -
PLOT DATE = 9/4/2024	DATE - 06-10-2024	FILE - 2325873_SHT-Plan1.dgn

STATE OF ILLINOIS  
 DEPARTMENT OF TRANSPORTATION

ROADWAY PLAN  
 BURLINGTON AVENUE  
 SCALE: 1" = 20'  
 SHEET 1 OF 2 SHEETS  
 STA. 10+00 TO STA. 21+00

F.A.U. RTE.	SECTION	COUNTY	TOTAL SHEETS	SHEET NO.
3783	23-00104-00-R5	COOK	20	10
CONTRACT NO. 61K56				
ILLINOIS FED. AID PROJECT 18R(610)				

STATE OF ILLINOIS - PROFESSIONAL DESIGN FIRM  
 LICENSE NO. - 184-001121 - EXPIRES 4/30/2025  
 SHYDER CONSULTING ENGINEERS  
 9/4/2024  
 FILE NAME: P:\SPR\2325873-Burlington Ave STP D\CAD\06\_Microstation\Sheets\2325873\_SHT-Plan2.dgn

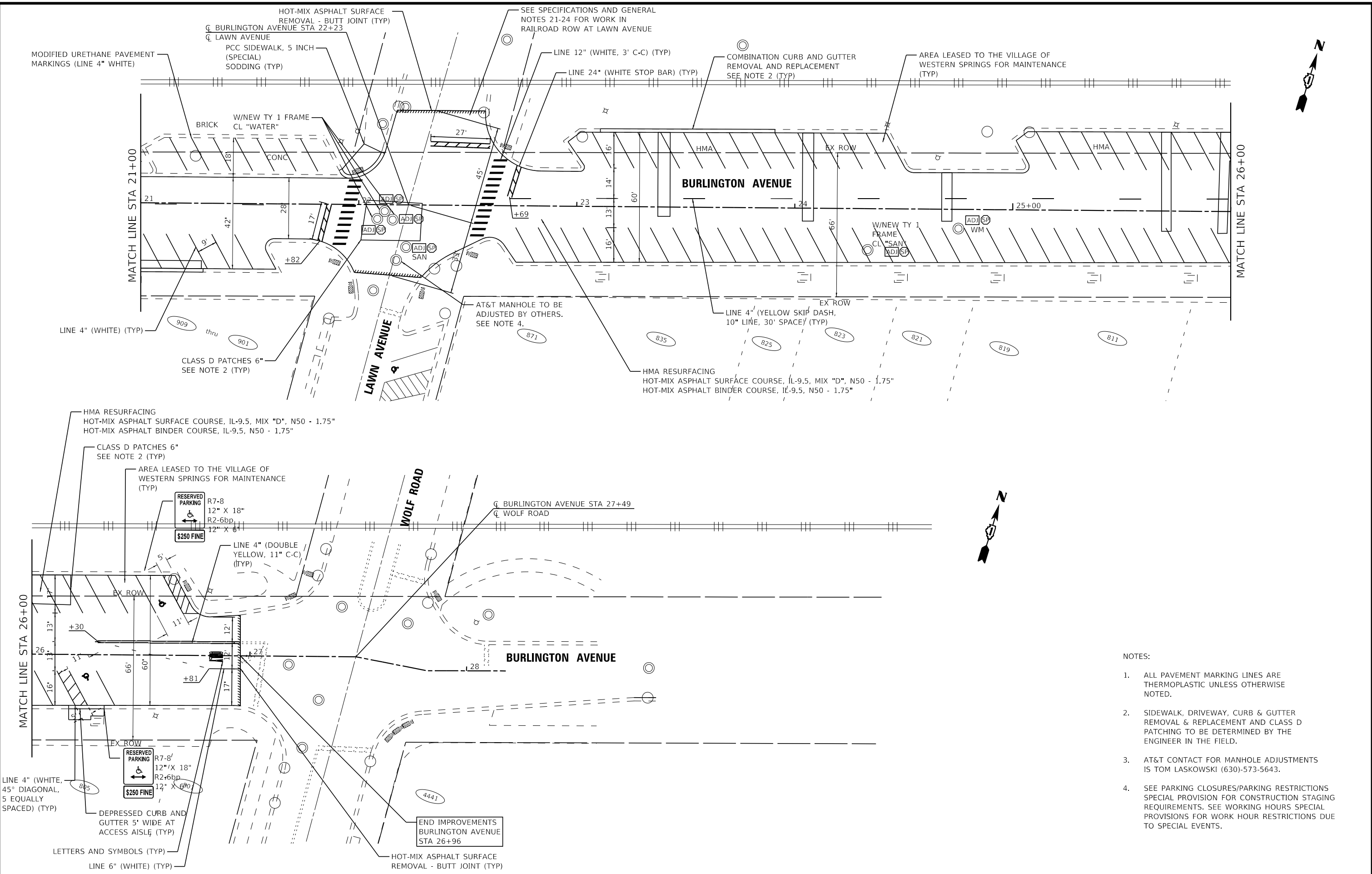

- NOTES:
- ALL PAVEMENT MARKING LINES ARE THERMOPLASTIC UNLESS OTHERWISE NOTED.
  - SIDEWALK, DRIVEWAY, CURB & GUTTER REMOVAL & REPLACEMENT AND CLASS D PATCHING TO BE DETERMINED BY THE ENGINEER IN THE FIELD.
  - AT&T CONTACT FOR MANHOLE ADJUSTMENTS IS TOM LASKOWSKI (630)-573-5643.
  - SEE PARKING CLOSURES/PARKING RESTRICTIONS SPECIAL PROVISION FOR CONSTRUCTION STAGING REQUIREMENTS. SEE WORKING HOURS SPECIAL PROVISIONS FOR WORK HOUR RESTRICTIONS DUE TO SPECIAL EVENTS.

	USER NAME = shyder	DESIGNED - SH	REVISED -
	PLOT SCALE = 40.0000' / in.	DRAWN - KAR	REVISED -
	PLOT DATE = 9/4/2024	CHECKED - JBT	REVISED -
		DATE - 06-10-2024	FILE - 2325873_SHT-Plan2.dgn

STATE OF ILLINOIS  
 DEPARTMENT OF TRANSPORTATION

ROADWAY PLAN  
 BURLINGTON AVENUE

SCALE: 1" = 20'

SHEET 2 OF 2 SHEETS STA. 21+00 TO STA. 28+18

F.A.U. RTE.	SECTION	COUNTY	TOTAL SHEETS	SHEET NO.
3783	23-00104-00-R5	COOK	20	11
CONTRACT NO. 61K56				
ILLINOIS FED. AID PROJECT 10R(610)				

STATE OF ILLINOIS - PROFESSIONAL DESIGN FIRM  
 LICENSE NO. - 184-001121 - EXPIRES 4/30/2025  
 SHYDER CONSULTANTS  
 9/4/2024  
 ...\\p1driv\p1drif\BW\_Default.plt  
 ...\\p1driv\2325873\_Pen-PH2.tbl  
 P:\WSPRV\2325873-Burlington Ave STP D\CAD\06\_Microstation\Sheets\2325873\_SHT-MiscDetails.dgn  
 ...\\p1driv\p1drif\BW\_Default.plt  
 ...\\p1driv\2325873\_Pen-PH2.tbl  
 P:\WSPRV\2325873-Burlington Ave STP D\CAD\06\_Microstation\Sheets\2325873\_SHT-MiscDetails.dgn

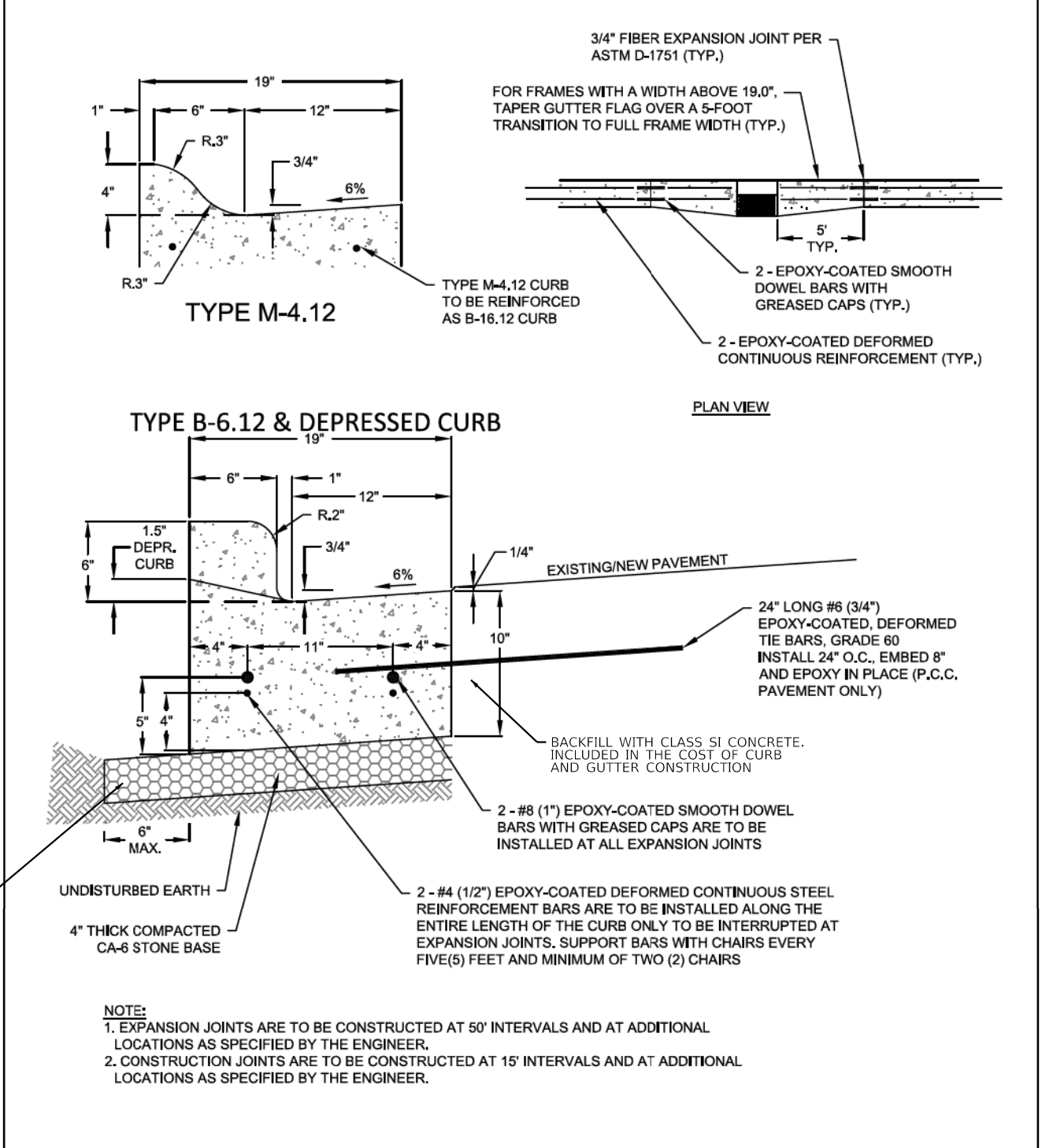
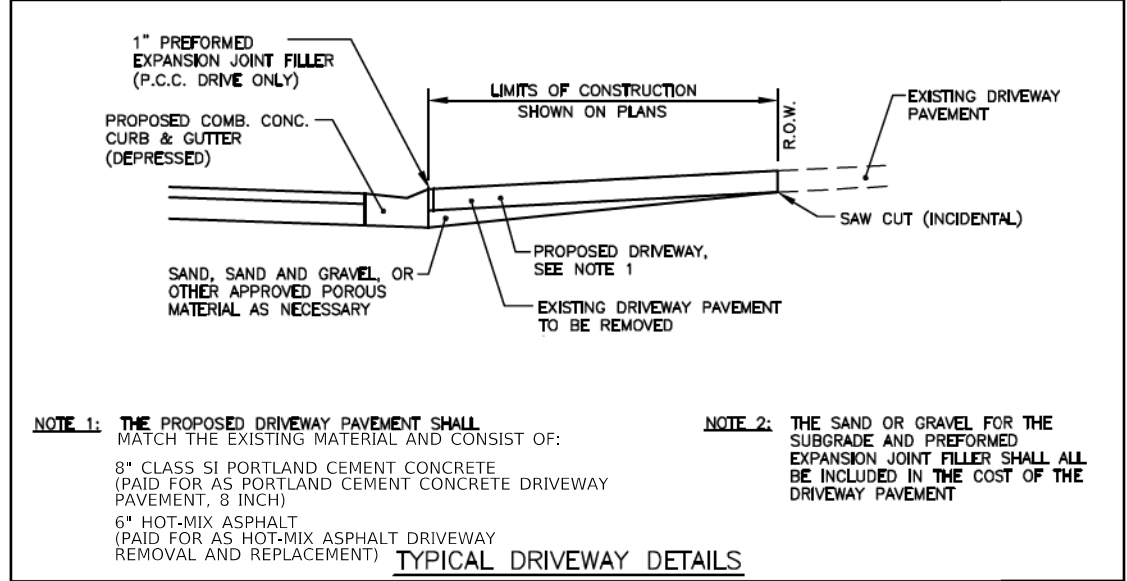

**Village of Western Springs**

**STANDARD DETAIL**

**COMBINATION CURB AND GUTTER DETAIL**

**P-4**

ISSUED: XX, 2024



USER NAME = shyder	DESIGNED - SH	REVISED -
PLOT SCALE = 40.0000 "/in.	CHECKED - JBT	REVISED -
PLOT DATE = 9/4/2024	DATE - 06-10-2024	FILE - 2325873_SHT-MiscDetails.dgn

STATE OF ILLINOIS  
DEPARTMENT OF TRANSPORTATION

**MISCELLANEOUS DETAILS**

SCALE: NONE SHEET 1 OF 2 SHEETS STA. TO STA.

F.A.U. RTE.	SECTION	COUNTY	TOTAL SHEETS	SHEET NO.
3783	23-00104-00-R5	COOK	20	12
CONTRACT NO. 61K56				
ILLINOIS FED. AID PROJECT 11R(0610)				

STATE OF ILLINOIS - PROFESSIONAL DESIGN FIRM  
 LICENSE NO. - 184-001121 - EXPIRES 4/30/2025  
 SHYDER CONSULTANTS  
 9/4/2024 12:19:32 PM  
 P:\SPR\2325873-Burlington Ave STP D\CAD\06\_Microstation\Sheets\2325873\_SHT-MiscDetails.dgn  
 P:\SPR\2325873-Burlington Ave STP D\CAD\06\_Microstation\Sheets\2325873\_SHT-MiscDetails.dgn

COMPARABLE IDOT TYPE	DESCRIPTION	OPTIONS
1	FLAT, ROUND, CLOSED LID	"SANITARY" LETTERING IMPRINTED ON UNBOLTED COVER. LID SHALL HAVE WATERTIGHT GASKET AND CONCEALED PICKHOLE.
		"STORM" LETTERING IMPRINTED ON COVER
		"WATER" LETTERING IMPRINTED ON COVER. LID SHALL HAVE CONCEALED PICKHOLE
1	FLAT, ROUND, OPEN TYPE D GRATE	N/A
3	COMBO INLET FRAME AND GRATE CURB BOX (NO CHURCH WINDOWS)	N/A

	BEEHIVE TYPE INLET, ROUND, OPEN GRATE FOR LAWN AREAS	N/A
--	--	-----



Village of Western Springs  
 STANDARD DETAIL  
 FRAME AND GRATE STANDARD  
 M-1

ISSUED: XX, 2024



USER NAME = shyder	DESIGNED - SH	REVISED -
	DRAWN - KAR	REVISED -
PLOT SCALE = 40.0000 ' / in.	CHECKED - JBT	REVISED -
PLOT DATE = 9/4/2024	DATE - 06-10-2024	FILE - 2325873_SHT-MiscDetails.dgn

STATE OF ILLINOIS  
 DEPARTMENT OF TRANSPORTATION

MISCELLANEOUS DETAILS			
SCALE: NONE	SHEET 2	OF 2 SHEETS	STA. TO STA.

F.A.U. RTE.	SECTION	COUNTY	TOTAL SHEETS	SHEET NO.
3783	23-00104-00-R5	COOK	20	13
CONTRACT NO. 61K56				
ILLINOIS FED. AID PROJECT 11R(610)				

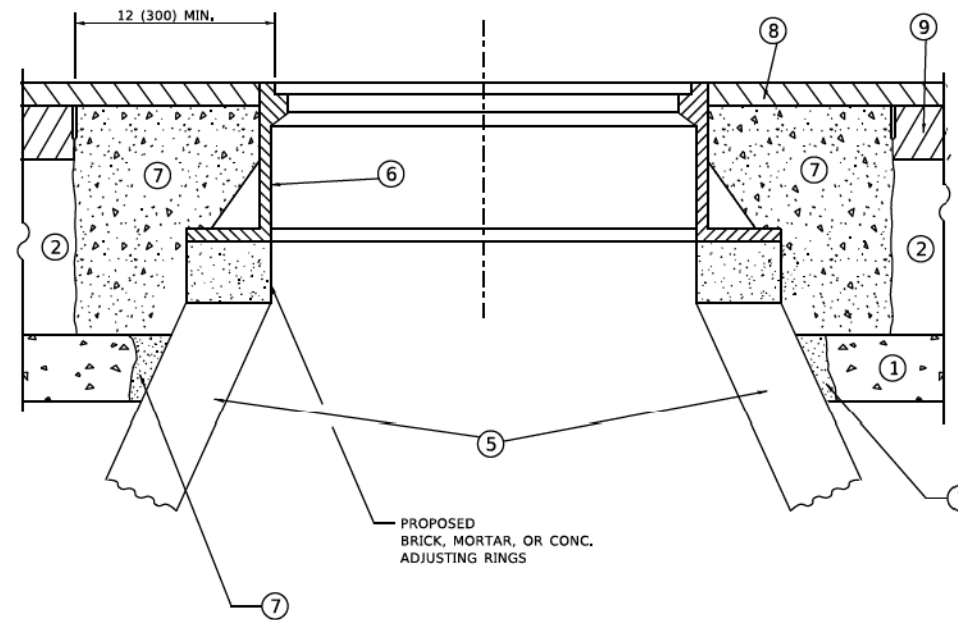
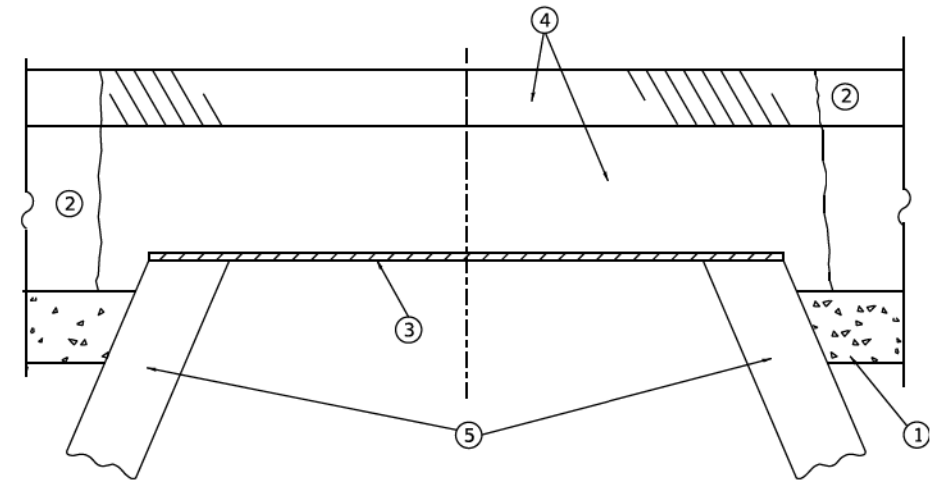

**DETAILS FOR FRAMES AND LIDS ADJUSTMENT  
WITH MILLING**

**CONSTRUCTION PROCEDURES**

**STAGE 1 (BEFORE PAVEMENT MILLING)**

- A) REMOVE A MINIMUM OF 12 (300) OF THE PAVEMENT FROM AROUND THE STRUCTURE.
- B) REMOVE THE EXISTING FRAME AND LID FROM THE STRUCTURE.
- C) COVER THE STRUCTURE OPENING WITH A 36 (900) DIAMETER METAL PLATE.
- D) BACKFILL WITH CRUSHED STONE AND HMA SURFACE MIX APPROVED BY THE ENGINEER. (MIN. 3 (80) HMA TO REMAIN AFTER MILLING).

**STAGE 2 (AFTER PAVEMENT MILLING)**

- A) REMOVE THE HMA SURFACE MIX AND CRUSHED STONE.
- B) INSTALL THE FRAME AND LID; ADJUST THE FRAME TO ITS FINAL SURFACE ELEVATION.
- C) THE SURROUNDING SPACE SHALL BE FILLED WITH CLASS PP-2\* CONCRETE TO THE ELEVATION OF THE SURFACE OF THE EXISTING BASE COURSE OR THE BINDER COURSE.

\* UNLESS OTHERWISE SPECIFIED IN THE PLANS.

THE PROCEDURE EXPLAINED ABOVE SHALL CONFORM TO THE APPLICABLE PORTIONS OF SECTIONS 353, 406, 602, AND 603 OF THE STANDARD SPECIFICATIONS EXCEPT THAT "THE CONTRACTOR SHALL ADJUST THE STRUCTURES TO THE FINISHED PAVEMENT ELEVATION NO MORE THAN 5 CALENDAR DAYS PRIOR TO PLACEMENT OF THE FINAL LIFT OF SURFACE UNLESS APPROVED BY THE ENGINEER."

**LEGEND**

- |  |                               |
|--|-------------------------------|
| ① SUB-BASE GRANULAR MATERIAL                 | ⑥ FRAME AND LID (SEE NOTES)   |
| ② EXISTING PAVEMENT                          | ⑦ CLASS PP-2* CONCRETE        |
| ③ 36 (900) DIAMETER METAL PLATE              | ⑧ PROPOSED HMA SURFACE COURSE |
| ④ PROPOSED CRUSHED STONE AND HMA SURFACE MIX | ⑨ PROPOSED HMA BINDER COURSE  |
| ⑤ EXISTING STRUCTURE                         |                               |

**LOCATION OF STRUCTURES**

THE CONTRACTOR WILL BE REQUIRED TO KEEP A RECORD OF THE LOCATIONS OF THE BURIED STRUCTURES ACCORDING TO THE STATION AND DISTANCE LEFT OR RIGHT OF THE CENTERLINE OF PAVEMENT. UPON COMPLETION OF THE WORK, THE CONTRACTOR WILL DELIVER THE RECORD TO THE ENGINEER.

**BASIS OF PAYMENT**

- 1. REMOVING FRAMES AND LIDS ON DRAINAGE AND UTILITY STRUCTURES IN THE PAVEMENT PRIOR TO MILLING, AND ADJUSTING TO FINAL GRADE PRIOR TO PLACING THE SURFACE COURSE, WILL BE PAID FOR AT THE CONTRACT UNIT PRICE EACH FOR "FRAMES AND LIDS TO BE ADJUSTED (SPECIAL)."
- 2. THIS WORK WILL NOT BE PAID FOR WHEN DRAINAGE AND UTILITY STRUCTURES ARE SPECIFIED FOR PAYMENT AS STRUCTURE RECONSTRUCTION.
- 3. NEW FRAMES AND LIDS, WHEN SPECIFIED, WILL BE PAID FOR SEPARATELY.
- 4. WHEN STRUCTURES ARE TO BE ADJUSTED OR RECONSTRUCTED, THE LOWERING AND RAISING OF THE FRAMES AND LIDS WILL NOT BE PAID FOR SEPARATELY BUT WILL BE INCLUDED IN THE COST OF THE CORRESPONDING PAY ITEM.

ALL DIMENSIONS ARE IN INCHES (MILLIMETERS) UNLESS OTHERWISE SHOWN

**NOTES**

- 1. EXISTING BROKEN FRAMES AND LIDS SHALL BE REMOVED AND DISPOSED OF BY THE CONTRACTOR AND SHALL BE REPLACED AS DIRECTED BY THE ENGINEER. REPLACEMENT FRAMES AND LIDS WILL BE PAID FOR IN ACCORDANCE WITH ARTICLE 109.04 OF THE STANDARD SPECIFICATIONS UNLESS A SEPARATE PAY ITEM HAS BEEN PROVIDED.
- 2. IF THE EXISTING LIDS ARE OPEN, THE FRAME WILL BE ADJUSTED TO THE ELEVATION OF THE MILLED PAVEMENT SURFACE PRIOR TO THE MILLING OPERATION. THE FRAME WILL NOT BE REMOVED AND COVERED BY THE METAL PLATE.
- 3. CITY OF CHICAGO CASTINGS ARE THE PROPERTY OF THE CITY AND THE CONTRACTOR SHALL NOTIFY THE CITY FOR REMOVAL AND DISPOSITION OF THE CASTINGS.
- 4. THE METAL PLATE USED TO COVER THE STRUCTURE SHALL REMAIN THE PROPERTY OF THE CONTRACTOR.
- 5. THE CONTRACTOR SHALL REMOVE ALL TRAFFIC CONTROL DEVICES BY THE END OF EACH WORK SHIFT.

MODEL: Default  
FILE: MANAGE\_V0101040323-010008.dgn

USER NAME = Lawrence,DeManche	DESIGNED - R. SHAH	REVISED - R. BORO 03-09-11
	DRAWN -	REVISED - R. BORO 12-06-11
PLOT SCALE = 100,0000' / 1" =	CHECKED -	REVISED - K. SMITH 11-18-22
PLOT DATE = 9/15/2023	DATE - 10-25-94	REVISED - K. SMITH 09-15-23

**STATE OF ILLINOIS  
DEPARTMENT OF TRANSPORTATION**

**DETAILS FOR  
FRAMES AND LIDS ADJUSTMENT WITH MILLING**

SCALE: NONE SHEET 1 OF 1 SHEETS STA. TO STA.

F.A. RTE.	SECTION	COUNTY	TOTAL SHEETS	SHEET NO.
3783	23-00104-00-RS	COOK	20	14
BD600-03 (BD-08)		CONTRACT NO. 61K56		
ILLINOIS FED. AID PROJECT				

**METHOD OF MEASUREMENT**

REFER TO SECTION 442 OF THE STANDARD SPECIFICATIONS FOR ROAD AND BRIDGE CONSTRUCTION AND THE RECURRING SPECIAL PROVISION "PATCHING WITH HOT-MIX ASPHALT OVERLAY REMOVAL."

**BASIS OF PAYMENT**

1. REFER TO SECTION 442 OF THE STANDARD SPECIFICATIONS FOR ROAD AND BRIDGE CONSTRUCTION AND THE RECURRING SPECIAL PROVISION "PATCHING WITH HOT-MIX ASPHALT OVERLAY REMOVAL."
2. SAW CUT/SCORING OF EXISTING HMA OVERLAY IS INCLUDED IN THE COST OF PAVEMENT PATCHING.
3. SAW CUT/SCORING OF EXISTING PAVEMENT IS INCLUDED IN THE COST OF PAVEMENT PATCHING.

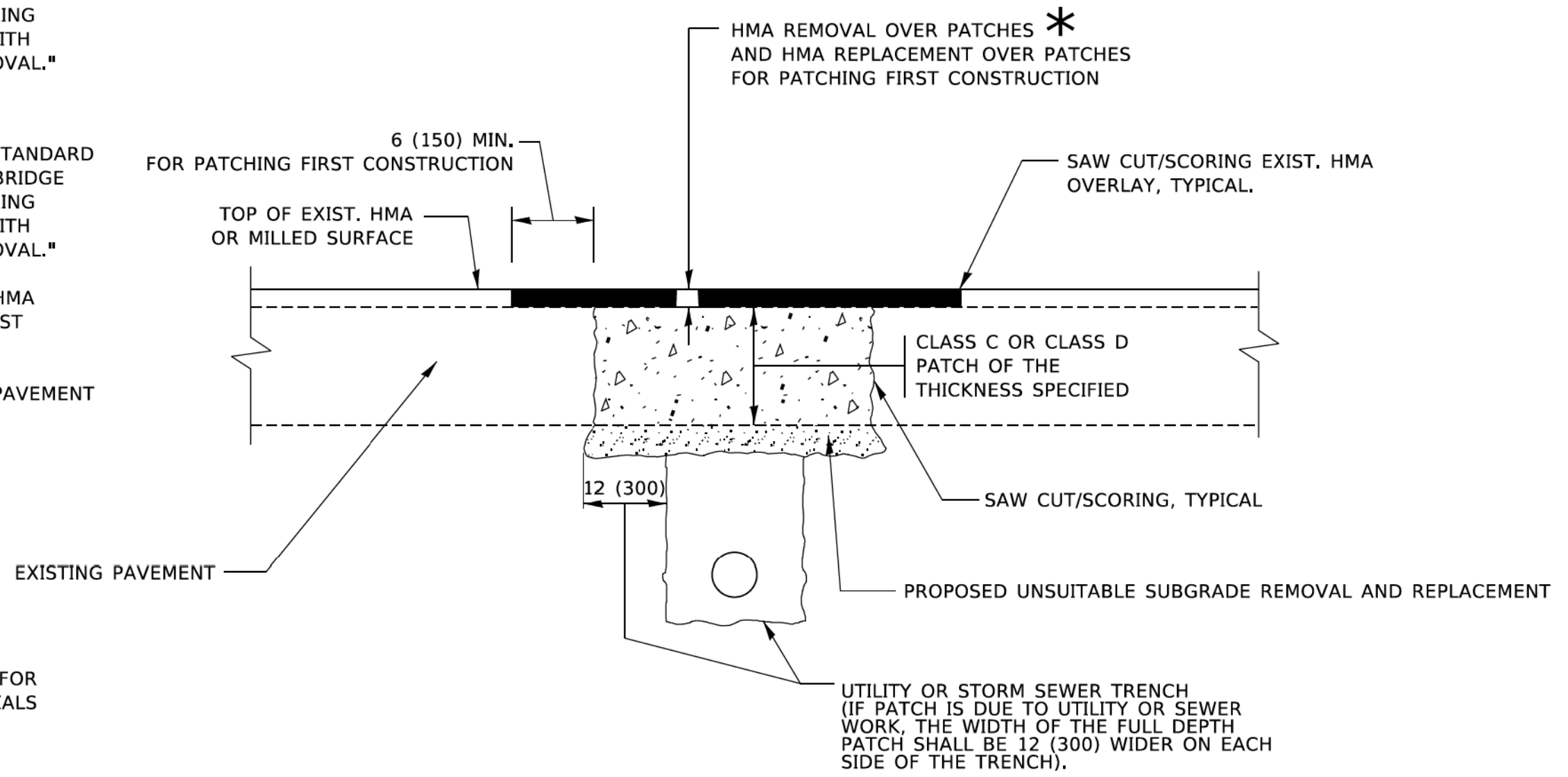

\* SEE TYPICAL SECTIONS FOR THICKNESS AND MATERIALS

**SEQUENCE OF CONSTRUCTION (PATCHING FIRST)**

1. REMOVE THE EXISTING HMA MATERIAL OVER THE AREA TO BE PATCHED.
2. REMOVE AND REPLACE WITH CLASS C OR D PATCH.
3. REPLACE HMA MATERIAL OVER THE AREA TO BE PATCHED.

**SEQUENCE OF CONSTRUCTION (MILLING FIRST)**

1. MILL HMA FIRST IF THERE IS AT LEAST 4½ INCHES OR MORE OF HMA MATERIAL ON TOP OF THE EXISTING PAVEMENT OR IF THE PAVEMENT IS FULL DEPTH HMA. A MINIMUM OF 2 INCHES OF HMA MATERIAL SHALL BE IN PLACE AFTER MILLING.
2. REMOVE AND REPLACE WITH FULL DEPTH CLASS D PATCHES TO TOP OF MILLED SURFACE.

ALL DIMENSIONS ARE IN INCHES (MILLIMETERS) UNLESS OTHERWISE SHOWN.

MODEL: Default; FILE: \\mms\proj\mms\clients\luc.com\p\1001\Documents\1001\_01\res\01\res\_1\proj\cadd\1001\1001\cadd\data\CAD\patches\bd22.dgn

USER NAME - Lawrence,DeManche	DESIGNED - R. SHAH	REVISED - R. BORO 01-01-07
PLOT SCALE = 100,0000' / 1in.	CHECKED -	REVISED - R. BORO 09-04-07
PLOT DATE = 11/18/2022	DATE - 10-25-94	REVISED - K. ENG 10-27-08
		REVISED - K. SMITH 11-18-22

STATE OF ILLINOIS  
DEPARTMENT OF TRANSPORTATION

PAVEMENT PATCHING FOR  
HMA SURFACED PAVEMENT

SCALE: NONE SHEET 1 OF 1 SHEETS STA. TO STA.

F.A. RTE. 3783	SECTION 23-00104-00-RS	COUNTY COOK	TOTAL SHEETS 20	SHEET NO. 15
BD400-04 (BD-22)		CONTRACT NO. 61K56		
ILLINOIS FED. AID PROJECT				

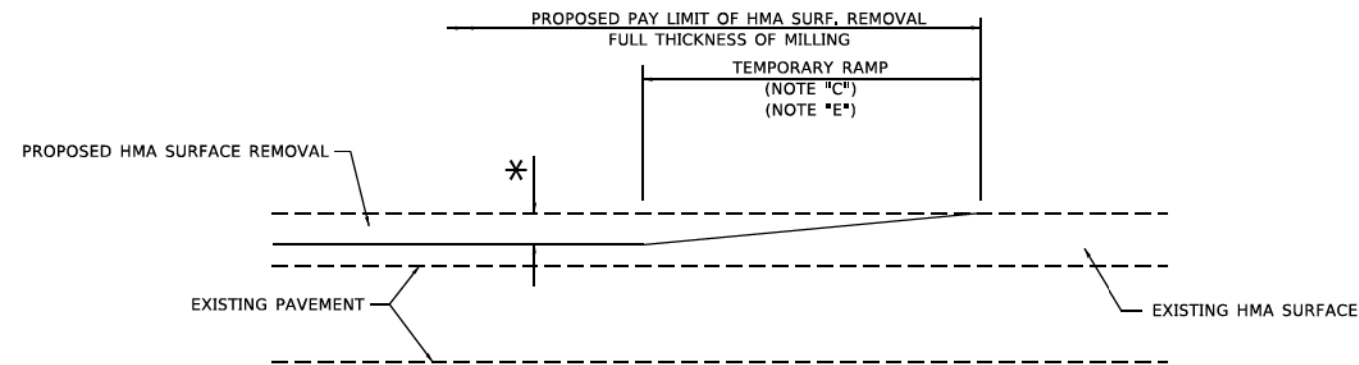

**MILLED TEMPORARY RAMP**

(FOR BUTT JOINT AND HMA TAPER SEE DETAIL BELOW)

**OPTION 1**

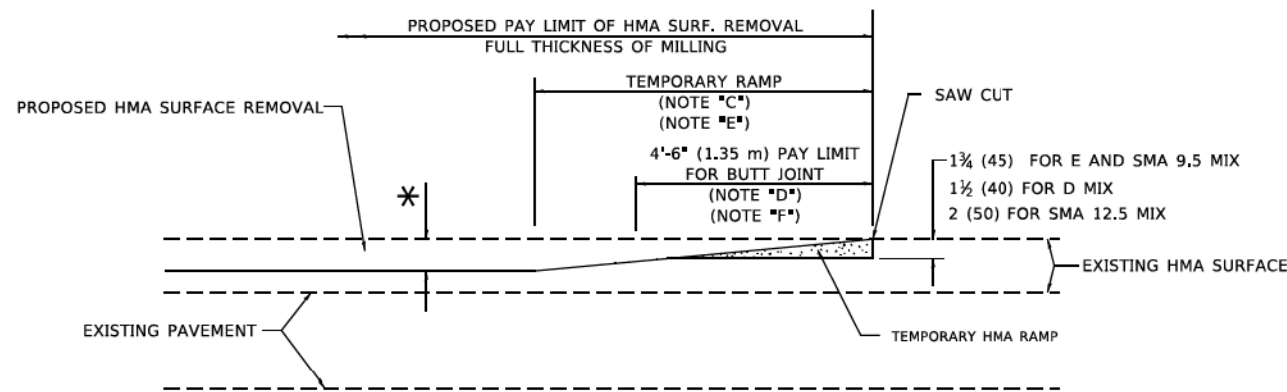

**HMA CONSTRUCTED TEMPORARY RAMP**

(FOR BUTT JOINT AND HMA TAPER SEE DETAIL BELOW)

**OPTION 2**

**TYPICAL TEMPORARY RAMP**

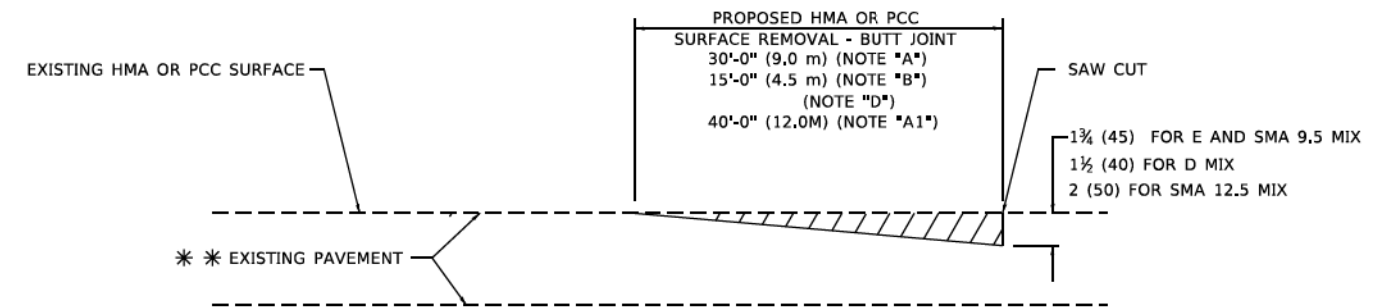

**BUTT JOINT DETAIL**

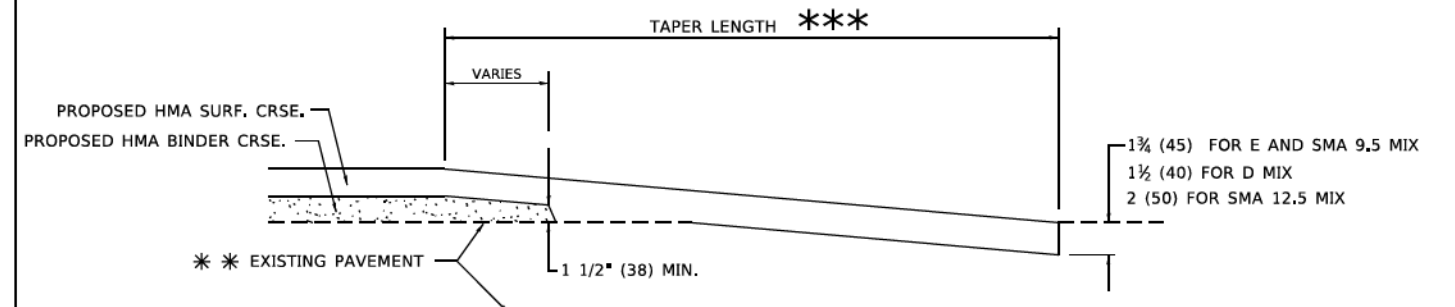

**HMA TAPER DETAIL**

**TYPICAL BUTT JOINT AND HMA TAPER FOR RESURFACING ONLY**

\*\*\* PC CONCRETE, HMA OR HMA RESURFACED PAVEMENT.

**GENERAL NOTES**

- A. MAINLINE ARTERIAL ROADWAYS AND MAJOR SIDE ROADS.
- A1. INTERSTATES
- B. MINOR SIDE ROADS.
- C. THE TEMP. RAMP SHALL BE CONSTRUCTED IMMEDIATELY UPON REMOVAL OF THE EXISTING HMA SURFACE.
- D. THE BUTT JOINT SHALL BE CONSTRUCTED IMMEDIATELY PRIOR TO PLACING THE PROPOSED HMA COURSES.
- E. TAPER THE TEMP. RAMP AT A RATE OF 3' - 4" (1.02m) PER 1 INCH (25 mm) OF MILLING THICKNESS.  
\* SEE TYPICAL SECTIONS FOR MILLING THICKNESS.
- F. SEE ARTICLE 406.08 AND 406.14 OF THE STANDARD SPECIFICATIONS FOR "HMA AND/OR PCC SURFACE REMOVAL, BUTT JOINT".  
\*\*\* 20'-0" (6.1 m) PER 1 (25) RESURFACING (NOTE "A")  
10'-0" (3.0 m) PER 1 (25) RESURFACING (NOTE "B")

**BASIS OF PAYMENT**

- 1. THE BUTT JOINT WILL BE PAID FOR AT THE CONTRACT UNIT PRICE PER SQUARE YARD (SQUARE METER) FOR "HOT-MIX ASPHALT SURFACE REMOVAL - BUTT JOINT" OR FOR "PORTLAND CEMENT CONCRETE SURFACE REMOVAL - BUTT JOINT".
- 2. THE TEMPORARY RAMP AND SAW CUT SHALL BE INCLUDED IN THE UNIT COST FOR HMA OR PCC SURFACE REMOVAL-BUTT JOINT.

ALL DIMENSIONS ARE IN INCHES (MILLIMETERS) UNLESS OTHERWISE SHOWN.

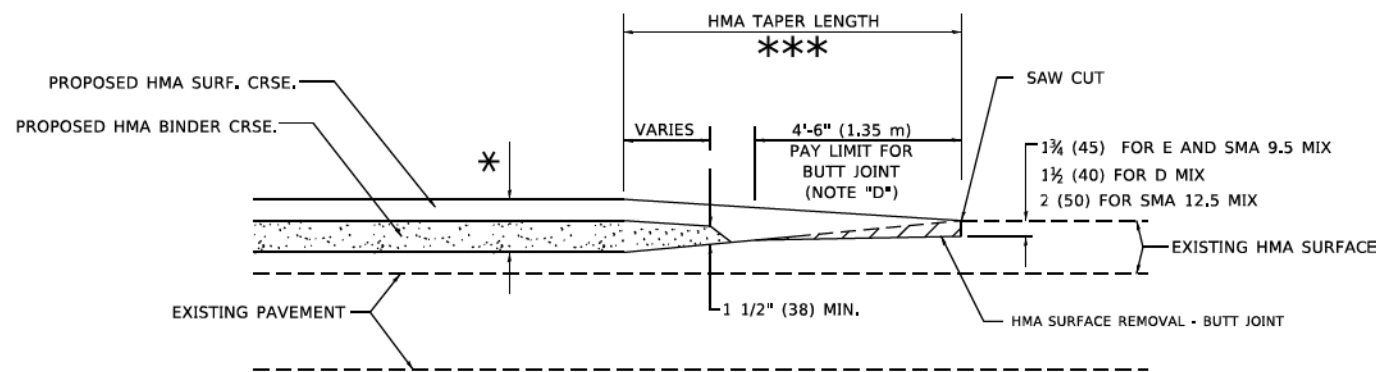

**BUTT JOINT AND HMA TAPER**

**TYPICAL BUTT JOINT AND HMA TAPER FOR MILLING AND RESURFACING**

MODEL: Default  
FILE: \\mills-portal-01\mills-portal\mills-portal\mills-portal\mills-portal\mills-portal\CAD\Drawings\B32.dgn

USER NAME - Lawrence,DeManche	DESIGNED - M. DE YONG	REVISED - A. ABBAS 03-21-97
PLOT SCALE = 100,0000' / 1" =	DRAWN -	REVISED - M. GOMEZ 04-06-01
PLOT DATE = 11/18/2022	CHECKED -	REVISED - R. BORO 01-01-07
	DATE - 06-13-90	REVISED - K. SMITH 11-18-22

STATE OF ILLINOIS  
DEPARTMENT OF TRANSPORTATION

BUTT JOINT AND  
HMA TAPER DETAILS

SCALE: NONE SHEET 1 OF 1 SHEETS STA. TO STA.

F.A. RTE. 3783	SECTION 23-00104-00-RS	COUNTY COOK	TOTAL SHEETS 20	SHEET NO. 16
BD400-05 BD-32		CONTRACT NO. 61K56		
ILLINOIS FED. AID PROJECT				



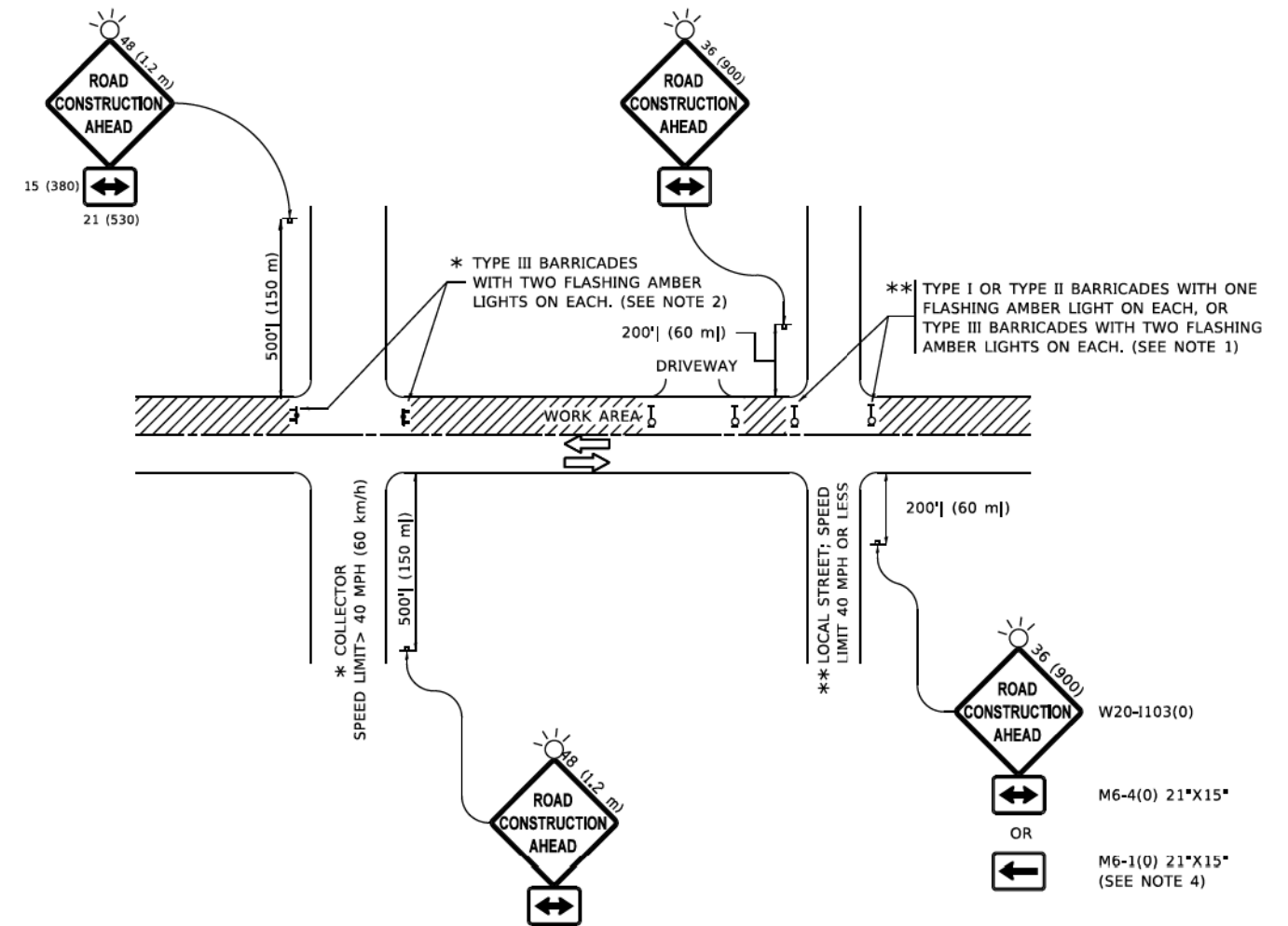

**NOTES:**

1. SIDE ROAD WITH A SPEED LIMIT OF 40 MPH (60 km/h) OR LESS AS SHOWN ON THE DRAWING AND AS DIRECTED BY THE ENGINEER:
  - a) ONE "ROAD CONSTRUCTION AHEAD" SIGN 36 x 36 (900x900) WITH A FLASHER MOUNTED ON IT APPROXIMATELY 200' (60 m) IN ADVANCE OF THE MAIN ROUTE.
  - b) THE CLOSED PORTION OF THE MAIN ROUTE SHALL BE PROTECTED BY BLOCKING WITH TYPE I, TYPE II OR TYPE III BARRICADES, 1/3 OF THE CROSS SECTION OF THE CLOSED PORTION.
2. SIDE ROAD WITH A SPEED LIMIT GREATER THAN 40 MPH (60 km/h) AS SHOWN ON THE DRAWING AND AS DIRECTED BY THE ENGINEER:
  - a) ONE "ROAD CONSTRUCTION AHEAD" SIGN 48 x 48 (1.2 m x 1.2 m) WITH A FLASHER MOUNTED ON IT APPROXIMATELY 500' (150 m) IN ADVANCE OF THE MAIN ROUTE.
  - b) THE CLOSED PORTION OF THE MAIN ROUTE SHALL BE PROTECTED BY BLOCKING WITH TYPE III BARRICADES, 1/2 OF THE CROSS SECTION OF THE CLOSED PORTION.
3. CONES MAY BE SUBSTITUTED FOR BARRICADES OR DRUMS AT HALF THE SPACING DURING DAY OPERATIONS, CONES SHALL BE A MINIMUM OF 28 (710) IN HEIGHT.
4. SIGNING AND THE WORK ZONE, A SINGLE HEADED ARROW (M6-1) SHALL BE USED IN LIEU OF THE DOUBLE HEADED ARROW (M6-4).
5. WHEN WORK IS BEING PERFORMED ON A SIDE ROAD OR DRIVEWAY, FOLLOW THE APPLICABLE STANDARD(S). THE DIRECTIONAL ARROW (M6-1 OR M6-4) SHALL BE COVERED OR REMOVED WHEN NO LONGER CONSISTENT WITH THE TRAFFIC CONTROL SET-UP.
6. ADVANCE WARNING SIGNS ARE TO BE OMITTED ON DRIVEWAYS UNLESS OTHERWISE SPECIFIED IN THE PLANS OR BY THE ENGINEER.
7. THE TRAFFIC CONTROL AND PROTECTION FOR SIDE ROADS, INTERSECTIONS, AND DRIVEWAYS SHALL BE INCLUDED IN THE COST OF SPECIFIED TRAFFIC CONTROL STANDARDS OR ITEMS.

All dimensions are in inches (millimeters) unless otherwise shown.

MODEL: Default  
 FILE: \\mms1-prod1-01\mms1-prod1-01\Projects\2024\24-0000\24-0000\CADD\24-0000\CAD\24-0000\24-0000.dgn

USER NAME	Lawrence,DeManche	DESIGNED	L.H.A.	REVISED	T. RAMMACHER 01-06-00
		DRAWN	-	REVISED	A. SCHUETZE 07-01-13
PLOT SCALE	= 100,0000 ' / in.	CHECKED	-	REVISED	A. SCHUETZE 09-15-16
PLOT DATE	= 5/3/2024	DATE	- 06-89	REVISED	D. SENDRAK 05-03-24

**STATE OF ILLINOIS  
DEPARTMENT OF TRANSPORTATION**

**TRAFFIC CONTROL AND PROTECTION FOR  
SIDE ROADS, INTERSECTIONS, AND DRIVEWAYS**

SCALE: NONE SHEET 1 OF 1 SHEETS STA. TO STA.

F.A. RTE.	SECTION	COUNTY	TOTAL SHEETS	SHEET NO.
3783	23-00104-00-RS	COOK	20	17
<b>TC-10</b>		CONTRACT NO. 61K56		
ILLINOIS FED. AID PROJECT				

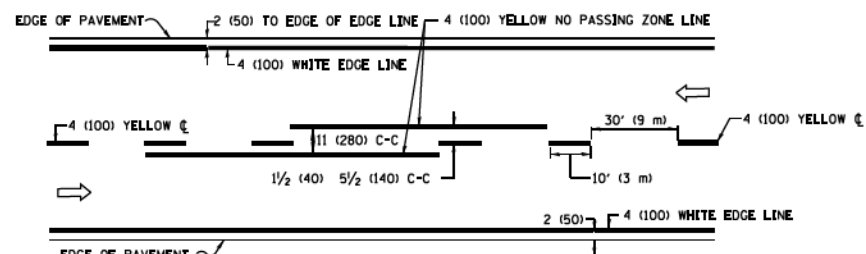

**2-LANE ROADWAY**

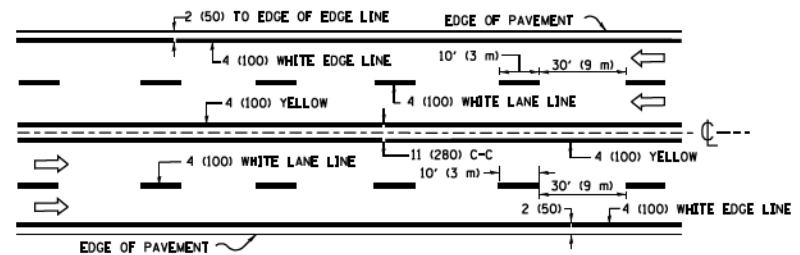

**MULTI-LANE UNDIVIDED**

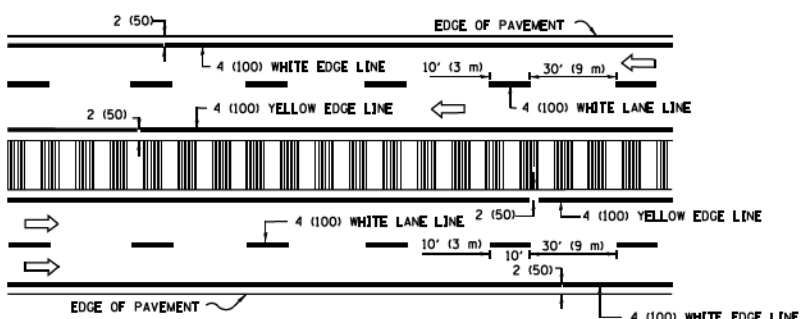

**MULTI-LANE DIVIDED WITH MEDIAN**

**TYPICAL LANE AND EDGE LINE MARKING**

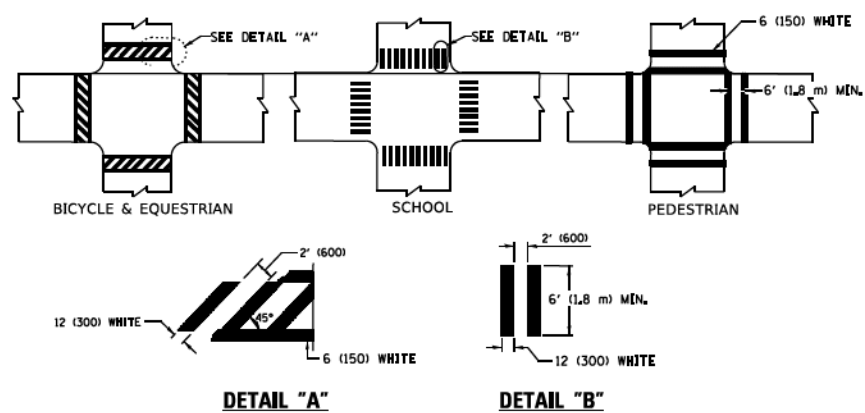

**TYPICAL CROSSWALK MARKING**

\* MARKINGS SHALL BE INSTALLED PARALLEL TO THE CENTERLINE OF THE ROAD WHICH IT CROSSES

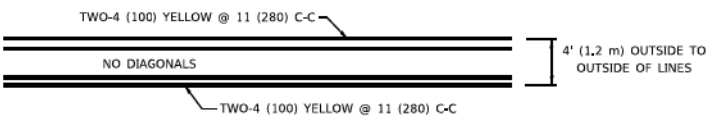

**4' (1.2 m) WIDE MEDIANS ONLY**

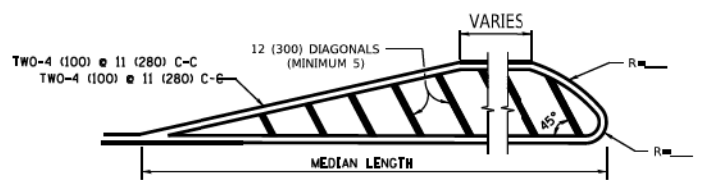

**MEDIANS OVER 4' (1.2 m) WIDE**

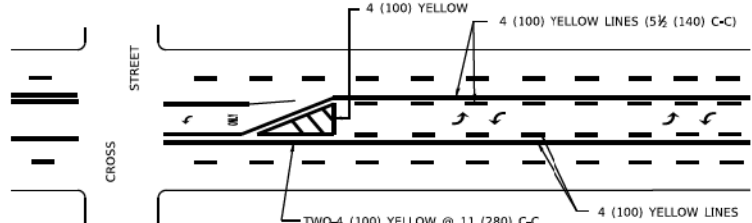

**MEDIAN WITH TWO-WAY LEFT TURN LANE  
TYPICAL PAINTED MEDIAN MARKING**

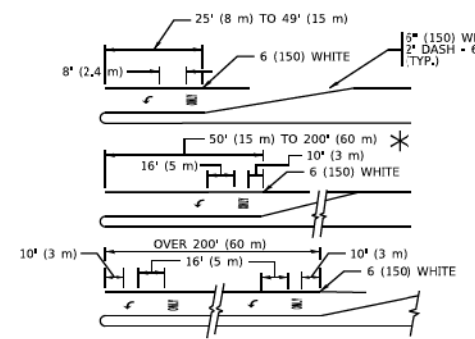

**TYPICAL LEFT (OR RIGHT) TURN LANE**

**TYPICAL TURN LANE MARKING**

FULL SIZE LETTERS 8" (2.4 m) AND ARROWS SHALL BE USED.  
 \* TURN LANES IN EXCESS OF 400' (120 m) IN LENGTH MAY HAVE AN ADDITIONAL SET OF ARROW - "ONLY" INSTALLED MIDWAY BETWEEN THE OTHER TWO SETS OF ARROW - "ONLY".

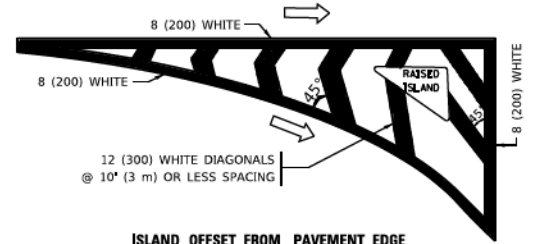

**ISLAND OFFSET FROM PAVEMENT EDGE**

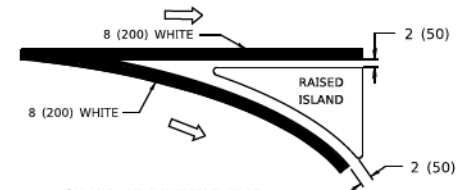

**ISLAND AT PAVEMENT EDGE**

**TYPICAL ISLAND MARKING**

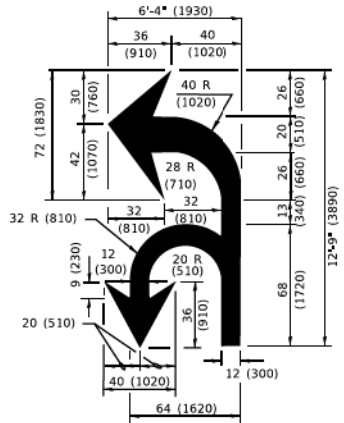

**COMBINATION LEFT AND U-TURN**

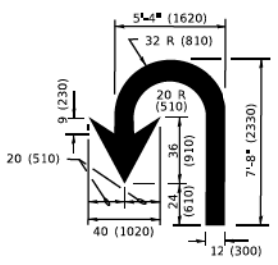

**U-TURN**

**LANE REDUCTION TRANSITION**  
 \* LANE REDUCTION ARROWS REQUIRED AT SPEEDS OF 45 MPH OR GREATER OR WHEN SPECIFIED IN PLANS.

D(FT)	SPEED LIMIT
345	30
425	35
500	40
580	45
665	50
750	55

TYPE OF MARKING	WIDTH OF LINE	PATTERN	COLOR	SPACING / REMARKS
CENTERLINE ON 2 LANE PAVEMENT	4 (100)	SKIP-DASH	YELLOW	10' (3 m) LINE WITH 30' (9 m) SPACE
CENTERLINE ON MULTI-LANE UNDIVIDED PAVEMENT	2 @ 4 (100)	SOLID	YELLOW	11 (280) C-C
NO PASSING ZONE LINES: FOR ONE DIRECTION FOR BOTH DIRECTIONS	4 (100) 2 @ 4 (100)	SOLID SOLID	YELLOW YELLOW	5 1/2 (140) C-C FROM SKIP-DASH CENTERLINE 11 (280) C-C OMIT SKIP-DASH CENTERLINE BETWEEN
LANE LINES	4 (100) 5 (125) ON FREEWAYS	SKIP-DASH SKIP-DASH	WHITE WHITE	10' (3 m) LINE WITH 30' (9 m) SPACE
DOTTED LINES (EXTENSIONS OF CENTER, LANE OR TURN LANE MARKINGS)	SAME AS LINE BEING EXTENDED	SKIP-DASH	SAME AS LINE BEING EXTENDED	2' (600) LINE WITH 6' (1.8 m) SPACE
EDGE LINES	4 (100)	SOLID	YELLOW-LEFT WHITE-RIGHT	OUTLINE MEDIANS IN YELLOW
TURN LANE MARKINGS	6 (150) LINE: FULL SIZE LETTERS & SYMBOLS (8" (2.4m))	SOLID	WHITE	SEE TYPICAL TURN LANE MARKING DETAIL
TWO WAY LEFT TURN MARKING	2 @ 4 (100) EACH DIRECTION 8" (2.4m) LEFT ARROW	SKIP-DASH AND SOLID IN PAIRS	YELLOW WHITE	10' (3 m) LINE WITH 30' (9 m) SPACE FOR SKIP-DASH; 5 1/2 (140) C-C BETWEEN SOLID LINE AND SKIP-DASH LINE SEE TYPICAL TWO-WAY LEFT TURN MARKING DETAIL
CROSSWALK LINES (PEDESTRIAN) A. DIAGONALS (BIKE & EQUESTRIAN) B. LONGITUDINAL BARS (SCHOOL)	2 @ 6 (150) 12 (300) @ 45° 12 (300) @ 90°	SOLID SOLID SOLID	WHITE WHITE WHITE	NOT LESS THAN 6' (1.8 m) APART 2' (600) APART 2' (600) APART SEE TYPICAL CROSSWALK MARKING DETAILS.
STOP LINES	24 (600)	SOLID	WHITE	PLACE 4' (1.2 m) IN ADVANCE OF AND PARALLEL TO CROSSWALK, IF PRESENT. OTHERWISE, PLACE AT DESIRED STOPPING POINT. PARALLEL TO CROSSROAD CENTERLINE, WHERE POSSIBLE.
PAINTED MEDIANS	2 @ 4 (100) WITH 12 (300) DIAGONALS @ 45° NO DIAGONALS USED FOR 4' (1.2 m) WIDE MEDIANS	SOLID	YELLOW: TWO WAY TRAFFIC WHITE: ONE WAY TRAFFIC	11 (280) C-C FOR THE DOUBLE LINE SEE TYPICAL PAINTED MEDIAN MARKING.
GORE MARKING AND CHANNELIZING LINES	8 (200) WITH 12 (300) DIAGONALS @ 45°	SOLID	WHITE	DIAGONALS: 15' (4.5 m) C-C (LESS THAN 30MPH (50 km/h)) 20' (6 m) C-C 30MPH (50 km/h) TO 45MPH (70 km/h) 30' (9 m) C-C (OVER 45MPH (70 km/h))
RAILROAD CROSSING	24 (600) TRANSVERSE LINES: "RR" 15 6" (1.8 m) LETTERS; 16 (400) LINE FOR "X"	SOLID	WHITE	SEE STATE STANDARD 780001 AREA OF: *R*=3.6 SQ. FT. (0.33 m²) EACH *X*=54.0 SQ. FT. (5.0 m²)
SHOULDER DIAGONALS (REQUIRED FOR SHOULDERS ≥ 8')	12 (300) @ 45°	SOLID	WHITE - RIGHT YELLOW - LEFT	50' (15 m) C-C (LESS THAN 30MPH (50 km/h)) 75' (25 m) C-C (30 MPH (50 km/h) TO 45MPH (70 km/h)) 150' (45 m) C-C (OVER 45MPH (70 km/h))
U TURN ARROW	SEE DETAIL	SOLID	WHITE	16.3 SF
2 ARROW COMBINATION LEFT AND U TURN	SEE DETAIL	SOLID	WHITE	30.4 SF

FOR FURTHER DETAILS ON PAVEMENT MARKING REFER TO STANDARD SPECIFICATIONS FOR ROAD AND BRIDGE CONSTRUCTION AND STATE STANDARD 780001.

All dimensions are in inches (millimeters) unless otherwise shown.

MODEL: D:\pav\110818\BNDTEC\110818\pav\110818\Documents\DOT\_Civil\cvt\110818\110818\110818\110818\CAD\Drawings\110818.dwg

USER NAME	DESIGNED	REVISED
footem	EVERS	C. JUCIUS 09-09-09
		C. JUCIUS 07-01-13
		C. JUCIUS 12-21-15
		C. JUCIUS 04-12-16

**STATE OF ILLINOIS  
DEPARTMENT OF TRANSPORTATION**

DISTRICT ONE TYPICAL PAVEMENT MARKINGS	
SCALE: NONE	SHEET 1 OF 2 SHEETS STA. TO STA.

F.A. RTE.	SECTION	COUNTY	TOTAL SHEETS	SHEET NO.
3783	23-00104-00-RS	COOK	20	18
TC-13		CONTRACT NO. 61K56		
ILLINOIS FED. AID PROJECT				



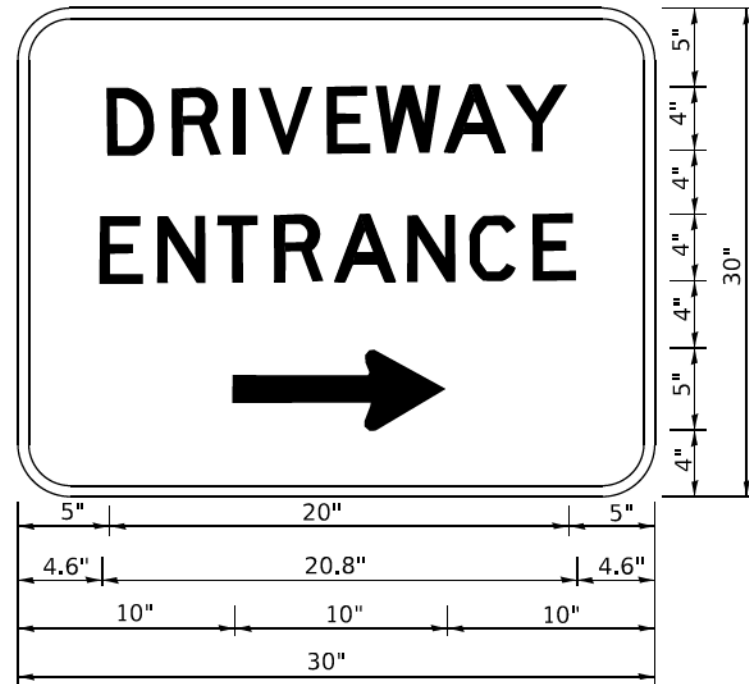

3.0" RADIUS, 0.5" BORDER, WHITE ON GREEN; REFLECTORIZED  
 "DRIVEWAY" D; "ENTRANCE" D; STANDARD ARROW CUSTOM 12.0" x 5.0"

NOTES:

1. HALF OF THE SIGNS WILL REQUIRE A LEFT HAND FACING ARROW.
2. TWO SIGNS SHALL BE USED AT EACH COMMERCIAL ENTRANCE PLACED BACK-TO-BACK: ONE WITH A RIGHT HAND ARROW (SHOWN) SHALL BE PLACED ON THE NEAR RIGHT SIDE THE DRIVEWAY AND ONE WITH A LEFT HAND ARROW SHALL BE PLACED ON THE FAR LEFT SIDE OF THE DRIVEWAY.
3. SIGNS TO BE PAID FOR AS ITEM "TEMPORARY INFORMATION SIGNING".

MODEL: Default  
 FILE NAME: p:\projects\DOT\Documents\DOT\_offices\butler\_1\projects\butler\_1\projects\butler\_1\CAD\Drawings\Drawings\126.dwg

USER NAME	leysa	DESIGNED	-	REVISED	- C. JUCIUS 02-15-07
PLOT SCALE	50,0000 1 / in.	DRAWN	-	REVISED	-
PLOT DATE	8/6/2021	CHECKED	-	REVISED	-
		DATE	-	REVISED	-

**STATE OF ILLINOIS  
 DEPARTMENT OF TRANSPORTATION**

**DRIVEWAY ENTRANCE SIGNING**

SCALE: NONE SHEET 1 OF 1 SHEETS STA. TO STA.

F.A. RTE.	SECTION	COUNTY	TOTAL SHEETS	SHEET NO.
3783	23-00104-00-RS	COOK	20	20
TC-26		CONTRACT NO. 61K56		
ILLINOIS FED. AID PROJECT				