

INDEX OF SHEETS

11-08-2024 LETTING ITEM 132

SHEET NO.	ITEM
1	COVER SHEET
2	GENERAL NOTES & COMMITMENTS
3-8	SUMMARY OF QUANTITIES
9-26	TYPICAL SECTIONS
27-30	SCHEDULES
31-48	PLAN & PROFILE SHEETS
49-54	TRAFFIC CONTROL PLAN
55-62	EROSION CONTROL PLANS
63-67	RIGHT OF WAY & TEMPORARY EASEMENT PLAN
68-73	INTERSECTION DETAILS
74-81	PAVEMENT MARKING & SIGNING PLAN
82-89	TRAFFIC SIGNAL PLANS & DETAILS
90-92	DETAILS
93	SOIL BORINGS
94-97	CULVERT PROFILES
98-132	FRANK SCOTT PARKWAY EAST CROSS SECTIONS
133-137	CROSS STREET CROSS SECTIONS
138-145	MAIN STREET CROSS SECTIONS
146-152	MAPLE STREET AND FRONTAGE ROAD CROSS SECTIONS
153-158	EXISTING MAPLE STREET CROSS SECTIONS
159	BOBBIE DRIVE CROSS SECTIONS
160-166	ILLINOIS ROUTE 158 CROSS SECTIONS

STANDARDS

000001-08	601101-02	606001-08	720001-01	886006-01
001001-02	602301-04	606101-05	720016-04	B.L.R. 22-7
280001-07	602306-03	606301-04	780001-05	
420001-10	602401-07	606401-02	781001-04	
420701-03	602406-11	667101-02	805001-01	
421001-03	602411-09	701006-05	814001-03	
421101-10	602601-06	701011-04	814006-03	
482001-02	602701-02	701306-04	857001-01	
482006-03	604001-05	701311-03	873001-02	
542001-06	604006-05	701326-04	877001-08	
542301-03	604036-03	701422-10	878001-11	
542306-03	604041-03	701701-10	880006-01	
601001-05	604091-05	701901-09	886001-01	

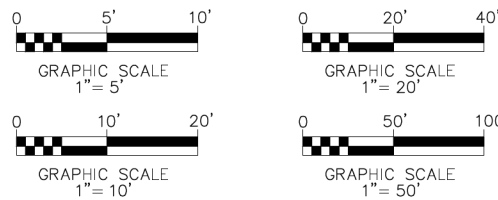

FULL SIZE PLANS HAVE BEEN PREPARED USING STANDARD ENGINEERING SCALES. REDUCED SIZED PLANS WILL NOT CONFORM TO STANDARD SCALES. IN MAKING MEASUREMENTS ON REDUCED PLANS, THE ABOVE SCALES MAY BE USED.

JOINT UTILITY LOCATING INFORMATION FOR EXCAVATIONS PHONE: 800-892-0123

FAU ROUTE 9330 (FRANK SCOTT PARKWAY EAST)
 DESIGN CLASSIFICATION = MINOR ARTERIAL - URBAN - TWS-2
 DESIGN SPEED = 50 MPH
 CURRENT TRAFFIC (2024) = 12,500 A.D.T.
 DESIGN YEAR TRAFFIC (2044) = 14,800 A.D.T.

FAU ROUTE 9173 (CROSS STREET)
 DESIGN CLASSIFICATION = MINOR ARTERIAL - URBAN - TWS-2
 DESIGN SPEED = 50 MPH
 CURRENT TRAFFIC (2024) = 10,100 A.D.T.
 DESIGN YEAR TRAFFIC (2044) = 11,200 A.D.T.

FAU ROUTE 9266 (MAIN STREET)
 DESIGN CLASSIFICATION = MINOR ARTERIAL - URBAN - TWS-2
 DESIGN SPEED = 50 MPH
 CURRENT TRAFFIC (2024) = 5,300 A.D.T.
 DESIGN YEAR TRAFFIC (2044) = 6,300 A.D.T.

FAU ROUTE 9176 (MAPLE STREET)
 DESIGN CLASSIFICATION = MINOR ARTERIAL - URBAN - TWS-2
 DESIGN SPEED = 45 MPH
 CURRENT TRAFFIC (2024) = 2,050 A.D.T.
 DESIGN YEAR TRAFFIC (2044) = 1,100 A.D.T.

FAP ROUTE 674 (IL RT 158)
 DESIGN CLASSIFICATION = PRINCIPAL ARTERIAL - URBAN - TWS-4
 DESIGN SPEED = 55 MPH
 CURRENT TRAFFIC (2024) = 17,000 A.D.T.
 DESIGN YEAR TRAFFIC (2044) = 18,800 A.D.T.

STATE OF ILLINOIS
 DEPARTMENT OF TRANSPORTATION
PLANS FOR PROPOSED
 FEDERAL AID PROJECT HPS FUNDS
FAU 9330 - FRANK SCOTT PARKWAY EAST
 SECTION: 95-00301-03-PV
 PROJECT NO: SMTQ(413)
 JOB NO: C-98-359-06
 ST. CLAIR COUNTY

SCALE IN FEET
 PLAN 1" = 50'
 PROFILE HORZ. 1" = 50'
 PROFILE VERT. 1" = 10'
 SECTIONS HORZ. 1" = 10'
 SECTIONS VERT. 1" = 5'

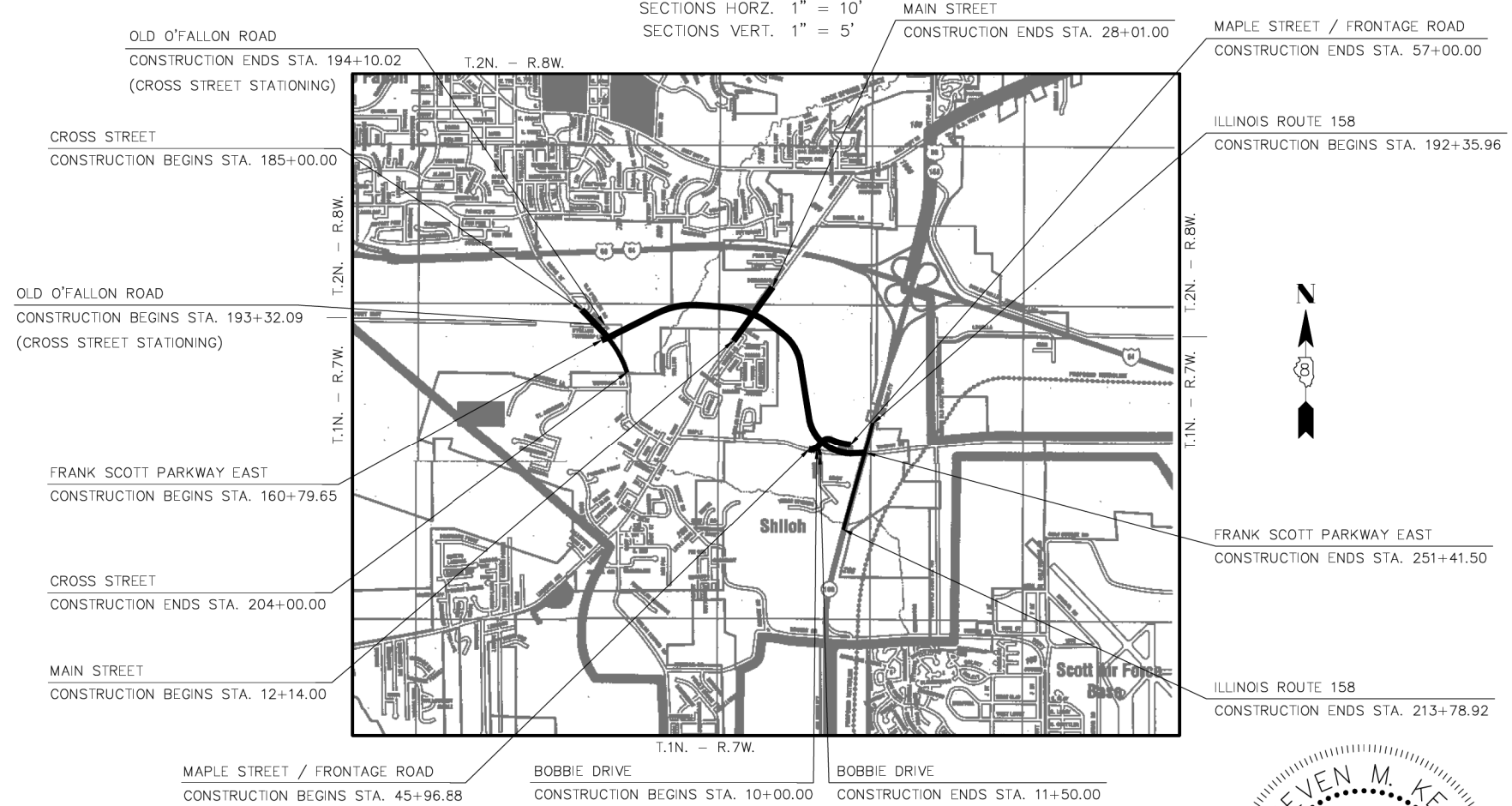

LOCATION MAP

SCALE 1" = 2,000'

GROSS LENGTH OF PROJECT = 9,061.85 FEET (1.716 MILES) FRANK SCOTT PARKWAY EAST
 GROSS LENGTH OF PROJECT = 1,900.00 FEET (0.369 MILES) CROSS STREET
 GROSS LENGTH OF PROJECT = 77.93 FEET (0.015 MILES) OLD O'FALLON ROAD
 GROSS LENGTH OF PROJECT = 1,587.00 FEET (0.301 MILES) MAIN STREET
 GROSS LENGTH OF PROJECT = 1,103.12 FEET (0.209 MILES) MAPLE STREET
 GROSS LENGTH OF PROJECT = 150.00 FEET (0.028 MILES) BOBBIE DRIVE
 GROSS LENGTH OF PROJECT = 2,142.96 FEET (0.406 MILES) IL RT 158
 TOTAL = 16,473.43 FEET (3.120 MILES)

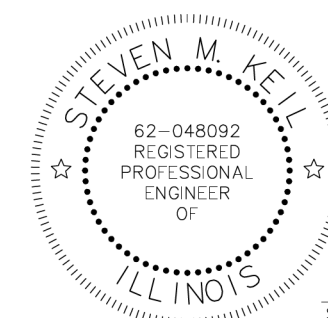

STEVEN M. KEIL
 P.E. NO. 062-048092
 EXPIRES 11/30/24

OATES ASSOCIATES
 Collinsville: 100 Lanter Court, Suite 1, Collinsville, IL 62234, 618.345.2200
 Belleville: 1 South Church Street, Suite 200, Belleville, IL 62200, 618.416.4688
 St. Louis: 720 Olive, Suite 700, St. Louis, MO 63101, 314.588.8381
 St. Charles: 820 South Main, Suite 309, St. Charles, MO 63301, 636.493.6277
 ILLINOIS DESIGN FIRM LICENSE NO.: 184.001115

F.A.U. RTE.	SECTION	COUNTY	TOTAL SHEETS	SHEET NO.
9330	95-00301-03-PV	ST. CLAIR	166	1
STA.		TO STA.		
FED. ROAD DIST. NO.		ILLINOIS	FED. AID PROJECT	
COVER SHEET				
CONTRACT NO.: 97372				

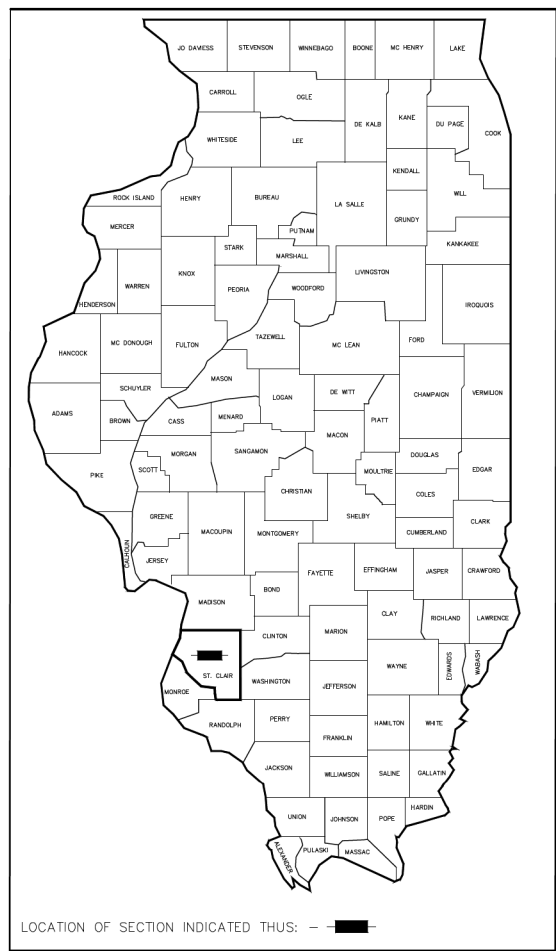

STATE OF ILLINOIS
 DEPARTMENT OF TRANSPORTATION

APPROVED: *Roman Steyer* DATE: 8/7/2024
 ST. CLAIR COUNTY ENGINEER

PASSED: *[Signature]* DATE: 8/28/2024
 DISTRICT 8 ENGINEER OF LOCAL ROADS & STREETS

RELEASING FOR BID BASED ON LIMITED REVIEW: *[Signature]* DATE: 8/28/2024
 REGION FIVE ENGINEER

F.A.U. RTE.	SECTION	COUNTY	TOTAL SHEETS	SHEET NO.
9330	95-00301-03-PV	ST. CLAIR	166	2
STA. X		TO STA. X		
FED. ROAD DIST. NO.		ILLINOIS	FED. AID PROJECT	
GENERAL NOTES & COMMITMENTS				

CONTRACT NO.: 97372

GENERAL NOTES

UTILITIES

- ABOVE-GROUND UTILITY FACILITIES OR APPURTENANCES SHALL BE RELOCATED OR ADJUSTED BY THEIR RESPECTIVE OWNERS TO PROVIDE A MINIMUM HORIZONTAL CLEARANCE OF 1.5 FEET, MEASURED FROM THE FACE OF CURB TO THE NEAR EDGE OF THE OBJECT.
- THE FOLLOWING UTILITY COMPANIES MAY HAVE FACILITIES LOCATED WITHIN THE LIMITS OF CONSTRUCTION WHICH MAY REQUIRE ADJUSTMENT, RELOCATION OR REMOVAL. REFER TO THE STATUS OF UTILITIES TO BE ADJUSTED SPECIAL PROVISION FOR ADDITIONAL INFORMATION.

AT&T (TELEPHONE)
203 GOETHE STREET
COLLINSVILLE, IL 62234
618-346-6400

CHARTER COMMUNICATIONS (COMMUNICATIONS)
317 WEST MAIN STREET
BELLEVILLE, IL 62220
618-277-2288

AMEREN IP (GAS & ELECTRIC)
1050 WEST BOULEVARD
BELLEVILLE, IL 62221
618-236-6200

VILLAGE OF SHILOH (SEWER)
1 PARK DRIVE
SHILOH, IL 62269
618-632-1022

ILLINOIS AMERICAN WATER CO. (WATER)
100 NORTH WATERWORKS DRIVE
BELLEVILLE, IL 62223
618-277-7450

ILLINOIS DEPARTMENT OF TRANSPORTATION (TRAFFIC SIGNALS)
1102 EASTPORT PLAZA DRIVE
COLLINSVILLE, IL 62234
618-346-3274

GENERAL

- PRIOR TO CONSTRUCTION, THE CONTRACTOR SHALL CONTACT THE LOCAL POSTMASTER FOR APPROVAL OF ALL TEMPORARY MAILBOX LOCATIONS. THE COST OF ALL MATERIALS REQUIRED AND ALL LABOR NECESSARY TO COMPLY WITH THIS PROVISION WILL NOT BE PAID FOR SEPARATELY, BUT SHALL BE CONSIDERED AS INCLUDED IN THE UNIT BID PRICES OF THE CONTRACT. O'FALLON POSTMASTER MICHAEL BEUTEL CAN BE CONTACTED AT 800-275-8777.
- IN CASE OF CONFLICT BETWEEN THE CONSTRUCTION PLANS AND THE RIGHT OF WAY PLANS, THE RIGHT OF WAY PLANS SHALL TAKE PRECEDENCE IN MATTERS CONCERNING RIGHT OF WAY AND EASEMENTS. THE CONSTRUCTION PLANS SHALL TAKE PRECEDENCE IN MATTERS CONCERNING CONSTRUCTION ITEMS.
- THE CONTRACTOR SHALL VERIFY ALL DIMENSIONS AND CONDITIONS IN THE FIELD PRIOR TO ORDERING MATERIALS AND COMMENCING CONSTRUCTION.
- THE CONTRACTOR SHALL STAGE ALL WORK IN SUCH A WAY AS TO MAINTAIN INGRESS AND EGRESS TO ALL ABUTTING PROPERTIES AT ALL TIMES DURING CONSTRUCTION. AGGREGATE FOR TEMPORARY ACCESS WILL BE MEASURED FOR PAYMENT AS SPECIFIED IN THE CONTRACT. THE COST OF ALL OTHER MATERIALS REQUIRED AND ALL OTHER LABOR NECESSARY TO COMPLY WITH THIS PROVISION WILL NOT BE PAID FOR SEPARATELY, BUT SHALL BE CONSIDERED AS INCLUDED IN THE UNIT BID PRICES OF THE CONTRACT.
- THE CONTRACTOR SHALL CONFINE ALL OPERATIONS TO THE CONSTRUCTION LIMITS LINE SHOWN ON THE PLANS. ANY AREA DISTURBED BEYOND THESE LIMITS SHALL BE RESTORED TO ITS ORIGINAL CONDITION AT THE CONTRACTOR'S EXPENSE.
- THE CONTRACTOR SHALL FERTILIZE, SEED AND MULCH ALL EARTH SURFACES DISTURBED BY CONSTRUCTION. FERTILIZER, SEEDING AND MULCH WITHIN THE CONSTRUCTION LIMITS WILL BE PAID FOR AS PROVIDED IN THE CONTRACT. FERTILIZER, SEEDING AND MULCH OUTSIDE THESE LIMITS WILL NOT BE MEASURED FOR PAYMENT. SEE THE SEEDING SCHEDULE FOR ESTIMATED PLAN QUANTITIES.

PAVING

- THE THICKNESS OF THE HOT-MIX ASPHALT MIXTURES SHOWN ON THE PLANS IS THE NOMINAL THICKNESS. DEVIATIONS FROM THE NOMINAL THICKNESS WILL BE PERMITTED WHEN SUCH DEVIATIONS OCCUR DUE TO IRREGULARITIES IN THE EXISTING SURFACE OR BASE ON WHICH THE HMA MIXTURES ARE PLACED.
- THE CONTRACTOR SHALL NOTE THE LOCATION OF ALL MANHOLE AND VALVE VAULT FRAMES AND LIDS LOCATED WITHIN THE RESURFACING LIMITS. APPROPRIATE CARE SHALL BE TAKEN TO PROTECT THESE ITEMS DURING MILLING OPERATIONS.
- AT VARIOUS LOCATIONS, IT MAY BE NECESSARY TO TRANSITION PROPOSED COMBINATION CONCRETE CURB AND GUTTER TO MEET EXISTING CURBS OR GUTTERS. THE MINIMUM LENGTH OF TRANSITIONAL COMBINATION CURB AND GUTTER SHALL BE 10 FEET, UNLESS DIRECTED OTHERWISE BY THE ENGINEER.

DRAINAGE

- ALL UPSTREAM AND DOWNSTREAM ENDS OF PROPOSED METAL CULVERTS SHALL BE FURNISHED BY THE CONTRACTOR WITH TAPERED ENDS UNLESS SPECIFIED OTHERWISE IN THE PLANS.
- STORM SEWER INVERTS SHOWN ON THE PLANS HAVE BEEN CALCULATED TO THE CENTER OF THE STRUCTURE. THE STORM SEWER SLOPES SHOWN ON THE PLANS ARE THE PERCENT GRADE FROM CENTER TO CENTER OF STRUCTURE. THE LENGTH OF STORM SEWERS SHOWN ON THE PLANS IS THE DISTANCE FROM CENTER TO CENTER OF STRUCTURE. STORM SEWER WILL BE MEASURED AND PAID FOR AS SPECIFIED IN ARTICLES 550.09 AND 550.10 OF THE STANDARD SPECIFICATIONS FOR ROAD AND BRIDGE CONSTRUCTION. FLARED END SECTIONS ARE LOCATED BY STATION, OFFSET AND FLOWLINE ELEVATION AT THE FLARED END OF THE FLARED END SECTION.
- STORM SEWERS AND CULVERTS MAY HAVE MINIMAL DEPTH BELOW THE MODIFIED SOIL LAYER. THE CONTRACTOR SHALL TAKE WHATEVER PRECAUTIONS ARE NECESSARY TO PROTECT THE PIPES FROM DAMAGE DURING THE SOIL MODIFICATION PROCESS. IN THE EVENT THAT PIPES ARE DAMAGED, THEY SHALL BE REPAIRED OR REPLACED TO THE SATISFACTION OF THE ENGINEER. ALL COSTS INCURRED TO REPAIR OR REPLACE DAMAGED PIPES SHALL BE AT THE CONTRACTOR'S EXPENSE.
- THE OFFSETS TO ALL INLETS AND MANHOLES ARE GIVEN TO THE CENTER OF THE OPENING AT THE BASE OF THE FRAME AND GRATE OR LID. CONCENTRIC DRAINAGE STRUCTURES WERE ASSUMED WHEN CALCULATING THESE DIMENSIONS.
- THE CONTRACTOR SHALL INCLUDE THE COST OF MAKING CONNECTIONS TO EXISTING DRAINAGE STRUCTURES IN THE CONTRACT UNIT PRICE FOR THE STORM SEWER ITEMS INVOLVED.

PAVEMENT MARKING

- THE CONTRACTOR SHALL APPLY SHORT-TERM OR TEMPORARY PAVEMENT MARKINGS TO THE MILLED, PRIMED AND EACH HOT-MIX ASPHALT LAYER. A QUANTITY FOR SHORT-TERM OR TEMPORARY PAVEMENT MARKING EQUAL TO THE AMOUNT OF PERMANENT PAVEMENT MARKING TIMES THE NUMBER OF REQUIRED APPLICATIONS HAS BEEN INCLUDED IN THE PLANS. ONLY THE FINAL APPLICATION OF SHORT-TERM OR TEMPORARY PAVEMENT MARKINGS SHALL BE REMOVED AND SEPARATE PAYMENT WILL BE MADE FOR WORK ZONE PAVEMENT MARKING REMOVAL.
- THE PAVEMENT MARKING LOCATIONS SHOWN IN THE PLANS ARE APPROXIMATE. PROPOSED CROSSWALKS AND STOP BARS SHALL BE ADJUSTED AS DIRECTED BY THE ENGINEER, IF NECESSARY, TO MATCH FIELD CONDITIONS.

APPROXIMATE QUANTITIES, SYMBOLS & ABBREVIATIONS

- THE FOLLOWING ITEMS AND APPROXIMATE QUANTITIES ARE INCLUDED IN THE SUMMARY OF QUANTITIES IN ORDER TO ESTABLISH A UNIT COST FOR WORK WHICH MAY BE REQUIRED TO CONSTRUCT THIS SECTION. THE ACTUAL QUANTITY OF EACH ITEM SHALL BE DETERMINED BY THE ENGINEER IN THE FIELD.

AGGREGATE FOR TEMPORARY ACCESS	400 TON
ENGINEER'S FIELD OFFICE, TYPE B	18 CAL MO

- THE FOLLOWING SYMBOLS AND ABBREVIATIONS SUPPLEMENT OR SUPERCEDE HIGHWAY STANDARD 000001:

AD	ALGEBRAIC DIFFERENCE IN GRADE
BVCE	BEGINNING OF VERTICAL CURVE ELEVATION
BVCS	BEGINNING OF VERTICAL CURVE STATION
BO	BY OTHERS (USED IN CONJUNCTION WITH TBA & TBR)
CONSTR	CONSTRUCTION
CP	CONTROL POINT
ESMT	EASEMENT
ELEV	ELEVATION
EVCE	END OF VERTICAL CURVE ELEVATION
EVCS	END OF VERTICAL CURVE STATION
K	LENGTH OF VERTICAL CURVE PER PERCENT GRADE DIFFERENCE
N/F	NOW OR FORMERLY
O/C	OIL AND CHIP
PERM	PERMANENT
PVI	POINT OF VERTICAL INTERSECTION
PVC	POLYVINYL CHLORIDE PIPE
TCE	TEMPORARY CONSTRUCTION EASEMENT
TUP	TEMPORARY USE PERMIT
TBA	TO BE ADJUSTED
TBRL	TO BE RELOCATED
TYP	TYPICAL
W	WIDTH

COMMITMENTS

NONE

FINAL SURVEY	SURVEYED	BY	DATE
NOTE	PLOTTED		
NO.	TEMPLATE		
	AREAS		
	CHECKED		

ORIGINAL SURVEY	SURVEYED	BY	DATE
NOTE	PLOTTED		
NO.	TEMPLATE		
	AREAS		
	CHECKED		

SUMMARY OF QUANTITIES

SPECIAL ITEM	PROJ SP	CODE NO.	ITEM	UNIT	TOTAL QUANTITIES
*		20100110	TREE REMOVAL (6 TO 15 UNITS DIAMETER)	UNIT	64
*		20100210	TREE REMOVAL (OVER 15 UNITS DIAMETER)	UNIT	60
*		20100500	TREE REMOVAL, ACRES	ACRE	9.25
		20400800	FURNISHED EXCAVATION	CU YD	113,444
*		20800150	TRENCH BACKFILL	CU YD	236
*	*	25000200	SEEDING, CLASS 2	ACRE	19.75
*		25000400	NITROGEN FERTILIZER NUTRIENT	POUND	1,783
*		25000500	PHOSPHORUS FERTILIZER NUTRIENT	POUND	1,783
*		25000600	POTASSIUM FERTILIZER NUTRIENT	POUND	1,783
*		25100115	MULCH, METHOD 2	ACRE	19.75
*		25100630	EROSION CONTROL BLANKET	SQ YD	11,488
		28000250	TEMPORARY EROSION CONTROL SEEDING	POUND	4,700
		28000305	TEMPORARY DITCH CHECKS	FOOT	2,917
		28000400	PERIMETER EROSION BARRIER	FOOT	9,379
		28000500	INLET AND PIPE PROTECTION	EACH	54
*		28100105	STONE RIPRAP, CLASS A3	SQ YD	3,301
		28200200	FILTER FABRIC	SQ YD	3,301
*	*	30200650	PROCESSING MODIFIED SOIL 12"	SQ YD	39,298
*		30201700	PORTLAND CEMENT	TON	1,016.5

SUMMARY OF QUANTITIES

SPECIAL ITEM	PROJ SP	CODE NO.	ITEM	UNIT	TOTAL QUANTITIES
		31100300	SUBBASE GRANULAR MATERIAL, TYPE A 4"	SQ YD	36,358
		31100900	SUBBASE GRANULAR MATERIAL, TYPE A 10"	SQ YD	323
		35100300	AGGREGATE BASE COURSE, TYPE A 4"	SQ YD	314
		35100500	AGGREGATE BASE COURSE, TYPE A 6"	SQ YD	458
		35100700	AGGREGATE BASE COURSE, TYPE A 8"	SQ YD	1,848
		35101100	AGGREGATE BASE COURSE, TYPE A, 12"	SQ YD	12,676
		35501325	HOT-MIX ASPHALT BASE COURSE, 10 1/4"	SQ YD	2,299
		40200500	AGGREGATE SURFACE COURSE, TYPE A 6"	SQ YD	242
		40201000	AGGREGATE FOR TEMPORARY ACCESS	TON	400
		40600275	BITUMINOUS MATERIALS (PRIME COAT)	POUND	4,833
		40600290	BITUMINOUS MATERIALS (TACK COAT)	POUND	8,608
		40600370	LONGITUDINAL JOINT SEALANT	FOOT	6,515
		40600990	TEMPORARY RAMP	SQ YD	40
		40602970	HOT-MIX ASPHALT BINDER COURSE, IL-9.5FG N70	TON	241
		40603085	HOT-MIX ASPHALT BINDER COURSE, IL-19.0, N70	TON	513
		40604012	HOT-MIX ASPHALT SURFACE COURSE, IL-9.5, MIX "D", N70	TON	1,004
		40701821	HOT-MIX ASPHALT PAVEMENT (FULL-DEPTH), 7"	SQ YD	126
		40701841	HOT-MIX ASPHALT PAVEMENT (FULL-DEPTH), 8"	SQ YD	1,454
		40701896	HOT-MIX ASPHALT PAVEMENT (FULL-DEPTH), 10 3/4"	SQ YD	1,193

F.A.U. RTE.	SECTION	COUNTY	TOTAL SHEETS	SHEET NO.
9330	95-00301-03-PV	ST. CLAIR	166	3
STA. X	TO STA. X			
FED. ROAD DIST. NO.	ILLINOIS	FED. AID PROJECT		
SUMMARY OF QUANTITIES				

CONTRACT NO.: 97372

FINAL SURVEY	SURVEYED	DATE
NOTE BOOTH	PLOTTED	
NO.	TEMPLATE	
	AREAS	CHECKED

ORIGINAL SURVEY	SURVEYED	DATE
NOTE BOOTH	PLOTTED	
NO.	TEMPLATE	
	AREAS	CHECKED

SUMMARY OF QUANTITIES

SPECIAL ITEM	PROJ SP	CODE NO.	ITEM	UNIT	TOTAL QUANTITIES
	*	40800050	INCIDENTAL HOT-MIX ASPHALT SURFACING	TON	85
		42000060	WELDED WIRE REINFORCEMENT	SQ YD	35,639
		42000300	PORTLAND CEMENT CONCRETE PAVEMENT 8"	SQ YD	3,420
		42000400	PORTLAND CEMENT CONCRETE PAVEMENT 9"	SQ YD	35,639
		42001300	PROTECTIVE COAT	SQ YD	40,375
		42300200	PORTLAND CEMENT CONCRETE DRIVEWAY PAVEMENT, 6 INCH	SQ YD	97
		44000100	PAVEMENT REMOVAL	SQ YD	9,281
	*	44000155	HOT-MIX ASPHALT SURFACE REMOVAL, 1 1/2"	SQ YD	4,446
		44000200	DRIVEWAY PAVEMENT REMOVAL	SQ YD	904
		44000500	COMBINATION CURB AND GUTTER REMOVAL	FOOT	3,193
	*	44003100	MEDIAN REMOVAL	SQ FT	2,996
		44004000	PAVED DITCH REMOVAL	FOOT	193
		44004250	PAVED SHOULDER REMOVAL	SQ YD	5,544
		48101200	AGGREGATE SHOULDERS, TYPE B	TON	1,883
		48203029	HOT-MIX ASPHALT SHOULDERS, 8"	SQ YD	21,351
		50104400	CONCRETE HEADWALL REMOVAL	EACH	3
	*	50105220	PIPE CULVERT REMOVAL	FOOT	465
		54001001	BOX CULVERT END SECTIONS, CULVERT NO. 1	EACH	2
		54001002	BOX CULVERT END SECTIONS, CULVERT NO. 2	EACH	2

SUMMARY OF QUANTITIES

SPECIAL ITEM	PROJ SP	CODE NO.	ITEM	UNIT	TOTAL QUANTITIES
	*	54010505	PRECAST CONCRETE BOX CULVERTS 5' X 5'	FOOT	16
	*	54010707	PRECAST CONCRETE BOX CULVERTS 7' X 7'	FOOT	140
		54213657	PRECAST REINFORCED CONCRETE FLARED END SECTIONS 12"	EACH	2
		54213669	PRECAST REINFORCED CONCRETE FLARED END SECTIONS 24"	EACH	10
		54213675	PRECAST REINFORCED CONCRETE FLARED END SECTIONS 30"	EACH	3
		54213687	PRECAST REINFORCED CONCRETE FLARED END SECTIONS 42"	EACH	3
		54213693	PRECAST REINFORCED CONCRETE FLARED END SECTIONS 48"	EACH	4
		54213711	PRECAST REINFORCED CONCRETE FLARED END SECTIONS 66"	EACH	2
		54214725	PRECAST REINFORCED CONCRETE FLARED END SECTIONS - ELLIPTICAL, EQUIVALENT ROUND-SIZE 30"	EACH	4
		54248510	CONCRETE COLLAR	CU YD	7.1
	*	542A0229	PIPE CULVERTS, CLASS A, TYPE 1 24"	FOOT	106
	*	542A1069	PIPE CULVERTS, CLASS A, TYPE 2 24"	FOOT	288
	*	542A1075	PIPE CULVERTS, CLASS A, TYPE 2 30"	FOOT	133
	*	542A1087	PIPE CULVERTS, CLASS A, TYPE 2 42"	FOOT	98
	*	542A1111	PIPE CULVERTS, CLASS A, TYPE 2 66"	FOOT	115
	*	542A2773	PIPE CULVERTS, CLASS A, TYPE 4 48"	FOOT	280
	*	542A3403	PIPE CULVERTS, CLASS A, TYPE 5 48"	FOOT	221
	*	542A5485	PIPE CULVERTS, CLASS A, TYPE 1 EQUIVALENT ROUND-SIZE 30"	FOOT	157
		542D0220	PIPE CULVERTS, CLASS D, TYPE 1 15"	FOOT	315

F.A.U. RTE.	SECTION	COUNTY	TOTAL SHEETS	SHEET NO.
9330	95-00301-03-PV	ST. CLAIR	166	4
STA. X	TO STA. X			
FED. ROAD DIST. NO.	ILLINOIS	FED. AID PROJECT		
SUMMARY OF QUANTITIES				
CONTRACT NO.: 97372				

FINAL SURVEY	SURVEYED	BY	DATE
NOTE	PLOTTED		
NO.	TEMPLATE		
	AREAS	CHECKED	
	AREAS	CHECKED	

ORIGINAL SURVEY	SURVEYED	BY	DATE
NOTE	PLOTTED		
NO.	TEMPLATE		
	AREAS	CHECKED	
	AREAS	CHECKED	

SUMMARY OF QUANTITIES

SPECIAL ITEM	PROJ SP	CODE NO.	ITEM	UNIT	TOTAL QUANTITIES
		542D0229	PIPE CULVERTS, CLASS D, TYPE 1 24"	FOOT	52
		542D1075	PIPE CULVERTS, CLASS D, TYPE 2 30"	FOOT	248
	*	550A0050	STORM SEWERS, CLASS A, TYPE 1 12"	FOOT	231
	*	550A0120	STORM SEWERS, CLASS A, TYPE 1 24"	FOOT	244
	*	550A0140	STORM SEWERS, CLASS A, TYPE 1 30"	FOOT	207
	*	550A0340	STORM SEWERS, CLASS A, TYPE 2 12"	FOOT	154
	*	550A0360	STORM SEWERS, CLASS A, TYPE 2 15"	FOOT	151
	*	550A0410	STORM SEWERS, CLASS A, TYPE 2 24"	FOOT	210
	*	550A0660	STORM SEWERS, CLASS A, TYPE 3 15"	FOOT	93
		55100500	STORM SEWER REMOVAL 12"	FOOT	136
		55100900	STORM SEWER REMOVAL 18"	FOOT	450
		55101200	STORM SEWER REMOVAL 24"	FOOT	51
		60100060	CONCRETE HEADWALLS FOR PIPE DRAINS	EACH	13
		60108100	PIPE UNDERDRAINS 4" (SPECIAL)	FOOT	196
		60108104	PIPE UNDERDRAINS, TYPE 1, 4"	FOOT	5,438
		60218400	MANHOLES, TYPE A, 4'-DIAMETER, TYPE 1 FRAME, CLOSED LID	EACH	2
	*	60220200	MANHOLES, TYPE A, 4'-DIAMETER	EACH	4
	*	60222900	MANHOLES, TYPE A, 5'-DIAMETER	EACH	3
		60224010	MANHOLES, TYPE A, 6'-DIAMETER, TYPE 9 FRAME AND GRATE	EACH	1

SUMMARY OF QUANTITIES

SPECIAL ITEM	PROJ SP	CODE NO.	ITEM	UNIT	TOTAL QUANTITIES
	*	60224075	MANHOLES, TYPE A, 6'-DIAMETER	EACH	2
		60236200	INLETS, TYPE A, TYPE 8 GRATE	EACH	1
		60238800	INLETS, TYPE A	EACH	11
		60240303	INLETS, TYPE B, TYPE 9 FRAME AND GRATE	EACH	1
		60240395	INLETS, TYPE B	EACH	2
	*	60406510	FRAMES AND LIDS (SALVAGED)	EACH	22
		60500040	REMOVING MANHOLES	EACH	3
		60500060	REMOVING INLETS	EACH	11
		60500105	FILLING MANHOLES	EACH	14
		60600095	CLASS SI CONCRETE (OUTLET)	CU YD	10.0
		60602500	CONCRETE GUTTER, TYPE A	FOOT	874
		60605000	COMBINATION CONCRETE CURB AND GUTTER, TYPE B-6.24	FOOT	3,410
		60610400	COMBINATION CONCRETE CURB AND GUTTER, TYPE M-6.24	FOOT	391
		60617310	PAVED DITCH, TYPE B-22	FOOT	69
	*	60618300	CONCRETE MEDIAN SURFACE, 4 INCH	SQ FT	2,895
		60622800	CONCRETE MEDIAN, TYPE SM-6.12	FOOT	947
		66700205	PERMANENT SURVEY MARKERS, TYPE I	EACH	24
	*	66900200	NON-SPECIAL WASTE DISPOSAL	CU YD	78
	*	66900530	SOIL DISPOSAL ANALYSIS	EACH	1

F.A.U. RT.	SECTION	COUNTY	TOTAL SHEETS	SHEET NO.
9330	95-00301-03-PV	ST. CLAIR	166	5
STA. X	TO STA. X			
FED. ROAD DIST. NO.	ILLINOIS	FED. AID PROJECT		
SUMMARY OF QUANTITIES				
CONTRACT NO.: 97372				

FINAL SURVEY PLOTTED	DATE
NOTE BOOK TEMPLATE	
AREAS CHECKED	
NO.	

ORIGINAL SURVEY PLOTTED	DATE
NOTE BOOK TEMPLATE	
AREAS CHECKED	
NO.	

SUMMARY OF QUANTITIES

SPECIAL ITEM	PROJ SP	CODE NO.	ITEM	UNIT	TOTAL QUANTITIES
*	*	66901001	REGULATED SUBSTANCES PRE-CONSTRUCTION PLAN	L SUM	1
*	*	66901003	REGULATED SUBSTANCES FINAL CONSTRUCTION REPORT	L SUM	1
*	*	66901006	REGULATED SUBSTANCES MONITORING	CAL DA	2
		67000500	ENGINEER'S FIELD OFFICE, TYPE B	CAL MO	18
		67100100	MOBILIZATION	L SUM	1
		70300100	SHORT TERM PAVEMENT MARKING	FOOT	1,622
		70300150	SHORT TERM PAVEMENT MARKING REMOVAL	SQ FT	540
		70300221	TEMPORARY PAVEMENT MARKING - LINE 4" - PAINT	FOOT	812
*		72000100	SIGN PANEL - TYPE 1	SQ FT	255.3
*		72000200	SIGN PANEL - TYPE 2	SQ FT	78.0
*		72800100	TELESCOPING STEEL SIGN SUPPORT	FOOT	235
*		73100100	BASE FOR TELESCOPING STEEL SIGN SUPPORT	EACH	19
*		78000100	THERMOPLASTIC PAVEMENT MARKING - LETTERS AND SYMBOLS	SQ FT	515
*		78000200	THERMOPLASTIC PAVEMENT MARKING - LINE 4"	FOOT	13,525
*		78000400	THERMOPLASTIC PAVEMENT MARKING - LINE 6"	FOOT	2,906
*		78000500	THERMOPLASTIC PAVEMENT MARKING - LINE 8"	FOOT	2,262
*		78000600	THERMOPLASTIC PAVEMENT MARKING - LINE 12"	FOOT	279
*		78000650	THERMOPLASTIC PAVEMENT MARKING - LINE 24"	FOOT	54
*		78008200	POLYUREA PAVEMENT MARKING TYPE I - LETTERS AND SYMBOLS	SQ FT	530

SUMMARY OF QUANTITIES

SPECIAL ITEM	PROJ SP	CODE NO.	ITEM	UNIT	TOTAL QUANTITIES
*		78008210	POLYUREA PAVEMENT MARKING TYPE I - LINE 4"	FOOT	48,527
*		78008240	POLYUREA PAVEMENT MARKING TYPE I - LINE 8"	FOOT	1,512
*		78008250	POLYUREA PAVEMENT MARKING TYPE I - LINE 12"	FOOT	2,253
*		78008270	POLYUREA PAVEMENT MARKING TYPE I - LINE 24"	FOOT	342
*		78100100	RAISED REFLECTIVE PAVEMENT MARKER	EACH	625
*		78200020	CURB REFLECTORS	EACH	41
		78300200	RAISED REFLECTIVE PAVEMENT MARKER REMOVAL	EACH	69
		78300202	PAVEMENT MARKING REMOVAL - WATER BLASTING	SQ FT	2,804
		81028170	UNDERGROUND CONDUIT, GALVANIZED STEEL, 1" DIA.	FOOT	20
*		81028190	UNDERGROUND CONDUIT, GALVANIZED STEEL, 1 1/2" DIA.	FOOT	20
*		81028220	UNDERGROUND CONDUIT, GALVANIZED STEEL, 3" DIA.	FOOT	74
*		81028230	UNDERGROUND CONDUIT, GALVANIZED STEEL, 3 1/2" DIA.	FOOT	98
*		81028320	UNDERGROUND CONDUIT, PVC, 1" DIA.	FOOT	3,272
*		81028330	UNDERGROUND CONDUIT, PVC, 1 1/4" DIA.	FOOT	101
*		81028340	UNDERGROUND CONDUIT, PVC, 1 1/2" DIA.	FOOT	133
*		81028350	UNDERGROUND CONDUIT, PVC, 2" DIA.	FOOT	64
*		81028360	UNDERGROUND CONDUIT, PVC, 2 1/2" DIA.	FOOT	383
*		81028370	UNDERGROUND CONDUIT, PVC, 3" DIA.	FOOT	71
*		81028380	UNDERGROUND CONDUIT, PVC, 3 1/2" DIA.	FOOT	130

F.A.U. RTE.	SECTION	COUNTY	TOTAL SHEETS	SHEET NO.
9330	95-00301-03-PV	ST. CLAIR	166	6
STA. X	TO STA. X			
FED. ROAD DIST. NO.	ILLINOIS	FED. AID PROJECT		
SUMMARY OF QUANTITIES				
CONTRACT NO.: 97372				

FINAL SURVEYED	DATE
SURVEY PLOTTED	
NOTE BOOK TEMPLATE	
AREAS CHECKED	
NO.	

ORIGINAL SURVEYED	DATE
SURVEY PLOTTED	
NOTE BOOK TEMPLATE	
AREAS CHECKED	
NO.	

SUMMARY OF QUANTITIES

SPECIAL ITEM	PROJ. SP.	CODE NO.	ITEM	UNIT	TOTAL QUANTITIES
*		81028390	UNDERGROUND CONDUIT, PVC, 4" DIA.	FOOT	10
*		81028400	UNDERGROUND CONDUIT, PVC, 5" DIA.	FOOT	16
*		81400700	HANDHOLE, PORTLAND CEMENT CONCRETE	EACH	22
*	*	81400720	DOUBLE HANDHOLE, PORTLAND CEMENT CONCRETE	EACH	2
*		85000200	MAINTENANCE OF EXISTING TRAFFIC SIGNAL INSTALLATION	EACH	3
*		85700200	FULL-ACTUATED CONTROLLER AND TYPE IV CABINET	EACH	2
*		87301245	ELECTRIC CABLE IN CONDUIT, SIGNAL NO. 14 5C	FOOT	6,885
*		87301255	ELECTRIC CABLE IN CONDUIT, SIGNAL NO. 14 7C	FOOT	3,136
*		87301305	ELECTRIC CABLE IN CONDUIT, LEAD-IN, NO. 14 1 PAIR	FOOT	10,575
*		87301805	ELECTRIC CABLE IN CONDUIT, SERVICE, NO. 6 2 C	FOOT	20
*		87700220	STEEL MAST ARM ASSEMBLY AND POLE, 36 FT.	EACH	1
*		87700280	STEEL MAST ARM ASSEMBLY AND POLE, 48 FT.	EACH	1
*		87700320	STEEL MAST ARM ASSEMBLY AND POLE, 55 FT.	EACH	2
*		87700340	STEEL MAST ARM ASSEMBLY AND POLE, 58 FT.	EACH	1
*		87700400	STEEL MAST ARM ASSEMBLY AND POLE, 60 FT.	EACH	2
*		87700404	STEEL MAST ARM ASSEMBLY AND POLE, 62 FT.	EACH	3
*	*	87800200	CONCRETE FOUNDATION, TYPE D	FOOT	6
*		87800415	CONCRETE FOUNDATION, TYPE E 36-INCH DIAMETER	FOOT	152
*		88040070	SIGNAL HEAD, POLYCARBONATE, LED, 1-FACE, 3-SECTION, BRACKET MOUNTED	EACH	11

SUMMARY OF QUANTITIES

SPECIAL ITEM	PROJ. SP.	CODE NO.	ITEM	UNIT	TOTAL QUANTITIES
*		88040090	SIGNAL HEAD, POLYCARBONATE, LED, 1-FACE, 3-SECTION, MAST ARM MOUNTED	EACH	14
*		88040110	SIGNAL HEAD, POLYCARBONATE, LED, 1-FACE, 4-SECTION, BRACKET MOUNTED	EACH	1
*		88040120	SIGNAL HEAD, POLYCARBONATE, LED, 1-FACE, 4-SECTION, MAST ARM MOUNTED	EACH	1
*		88040150	SIGNAL HEAD, POLYCARBONATE, LED, 1-FACE, 5-SECTION, BRACKET MOUNTED	EACH	8
*		88040160	SIGNAL HEAD, POLYCARBONATE, LED, 1-FACE, 5-SECTION, MAST ARM MOUNTED	EACH	8
*		88200100	TRAFFIC SIGNAL BACKPLATE	EACH	23
*		88500100	INDUCTIVE LOOP DETECTOR	EACH	37
*	*	88600100	DETECTOR LOOP, TYPE I	FOOT	5,452
*	*	89502375	REMOVE EXISTING TRAFFIC SIGNAL EQUIPMENT	EACH	2
*	*	89502380	REMOVE EXISTING HANDHOLE	EACH	10
*	*	89502385	REMOVE EXISTING CONCRETE FOUNDATION	EACH	9
*		A2002656	TREE, CARYA ILLINOENSIS (PECAN), 2" CALIPER, BALLED AND BURLAPPED	EACH	151
*		A2002716	TREE, CARYA OVATA (SHAGBARK HICKORY), 2" CALIPER, BALLED AND BURLAPPED	EACH	149
*		A2005816	TREE, PLATANUS OCCIDENTALIS (SYCAMORE), 2" CALIPER, BALLED AND BURLAPPED	EACH	149
*		A2006516	TREE, QUERCUS BICOLOR (SWAMP WHITE OAK), 2" CALIPER, BALLED AND BURLAPPED	EACH	151
*		A2006716	TREE, QUERCUS MACROCARPA (BUR OAK), 2" CALIPER, BALLED AND BURLAPPED	EACH	149
*		A2006916	TREE, QUERCUS PALUSTRIS (PIN OAK), 2" CALIPER, BALLED AND BURLAPPED	EACH	150
*		A2C021G3	TREE, CARYA LACINIOSA (SHELLBARK HICKORY), CONTAINER GROWN, 3-GALLON	EACH	149
*		X0301834	STORM SEWER TO BE FILLED	FOOT	823

F.A.U. RTE.	SECTION	COUNTY	TOTAL SHEETS	SHEET NO.
9330	95-00301-03-PV	ST. CLAIR	166	7
STA. X	TO STA. X			
FED. ROAD DIST. NO.	ILLINOIS	FED. AID PROJECT		
SUMMARY OF QUANTITIES				

CONTRACT NO.: 97372

FINAL SURVEY PLOTTED	DATE
NOTE BOOK TEMPLATE	
AREAS CHECKED	
NO.	

ORIGINAL SURVEY PLOTTED	DATE
NOTE BOOK TEMPLATE	
AREAS CHECKED	
NO.	

SUMMARY OF QUANTITIES

F.A.U. RTE.	SECTION	COUNTY	TOTAL SHEETS	SHEET NO.
9330	95-00301-03-PV	ST. CLAIR	166	8
STA. X		TO STA. X		
FED. ROAD DIST. NO.	ILLINOIS	FED. AID PROJECT		
SUMMARY OF QUANTITIES				

CONTRACT NO.: 97372

SPECIAL ITEM	PROJ SP	CODE NO.	ITEM	UNIT	TOTAL QUANTITIES
	*	X2020410	EARTH EXCAVATION (SPECIAL)	CU YD	52,825
	*	X6640104	FENCE REMOVAL	FOOT	953
	*	X7010216	TRAFFIC CONTROL AND PROTECTION, (SPECIAL)	L SUM	1
	*	X8030108	LOCATING UNDERGROUND UTILITIES	L SUM	1
	* *	X8050115	SERVICE INSTALLATION, TYPE A (MODIFIED)	EACH	2
	*	Z0015560	DEBRIS REMOVAL	UNIT	1
	*	Z0018911	DRILL AND GROUT #6 TIE BARS	EACH	1,151
	*	Z0036200	PAINT CURB	FOOT	271
	*	Z0056608	STORM SEWER (WATER MAIN REQUIREMENTS) 12INCH	FOOT	97
	*	Z0056612	STORM SEWER (WATER MAIN REQUIREMENTS) 18 INCH	FOOT	450
#	*	Z0076600	TRAINEES	HOUR	3,000
#	*	Z0076604	TRAINEES TRAINING PROGRAM GRADUATE	HOUR	3,000

#0042

FINAL SURVEY	SURVEYED	DATE
NOTE BOOK	PLOTTED	
NO.	TEMPLATE	
	AREAS	
	CHECKED	

ORIGINAL SURVEY	SURVEYED	DATE
NOTE BOOK	PLOTTED	
NO.	TEMPLATE	
	AREAS	
	CHECKED	

F.A.U. RTE.	SECTION	COUNTY	TOTAL SHEETS	SHEET NO.
9330	95-00301-03-PV	ST. CLAIR	166	9
STA.		TO STA.		
FED. ROAD DIST. NO.		ILLINOIS	FED. AID PROJECT	
FRANK SCOTT PARKWAY EAST TYPICAL SECTIONS				

CONTRACT NO.: 97372

LEGEND

- ① EXISTING P.C.C. PAVEMENT AND PAVEMENT FABRIC
 - ② EXISTING HOT-MIX ASPHALT SURFACE COURSE
 - ③ EXISTING LIME MODIFIED SOILS
 - ④ EXISTING BITUMINOUS BASE COURSE
 - ⑤ EXISTING STABILIZED SUB-BASE
 - ⑥ EXISTING HOT-MIX ASPHALT BINDER COURSE
 - ⑦ EXISTING AGGREGATE BASE WITH BITUMINOUS SURFACE TREATMENT
 - ⑧ EXISTING HOT-MIX ASPHALT SHOULDERS
 - ⑨ PROPOSED HOT-MIX ASPHALT SHOULDERS, 8"
 - ⑩ PROPOSED PROCESSING MODIFIED SOIL, 12"
 - ⑪ PROPOSED SAWED LONGITUDINAL JOINT (SEE HIGHWAY STANDARD 420001)
 - ⑫ PROPOSED LONGITUDINAL CONSTRUCTION JOINT (SEE HIGHWAY STANDARD 420001)
 - ⑬ PROPOSED SUB-BASE GRANULAR MATERIAL, TYPE A, 4"
 - ⑭ PROPOSED PORTLAND CEMENT CONCRETE PAVEMENT, 9", TYPE A FINAL FINISH
 - ⑮ PROPOSED PAVEMENT WELDED WIRE REINFORCEMENT (SEE HIGHWAY STANDARD 420701)
 - ⑯ PROPOSED AGGREGATE SHOULDER, TYPE B
 - ⑰ PROPOSED CONCRETE GUTTER, TYPE A (SEE HIGHWAY STANDARD 606101)
 - ⑱ PROPOSED CONCRETE MEDIAN SURFACE, 4" (SEE HIGHWAY STANDARD 606301)
 - ⑲ PROPOSED HOT-MIX ASPHALT SURFACE COURSE, MIX D, N70, 1 1/2"
 - ⑳ PROPOSED HOT-MIX ASPHALT BINDER COURSE, IL-19.0, N70, 2 1/4"
 - ㉑ PROPOSED HOT-MIX ASPHALT BASE COURSE, 10 1/4"
 - ㉒ PROPOSED EARTH SHOULDER
 - ㉓ PROPOSED HOT-MIX ASPHALT PAVEMENT (FULL DEPTH), 7"
(1 1/2" SURFACE COURSE, 5 1/2" BINDER COURSE) (INITIAL BINDER LIFT THICKNESS = 3")
 - ㉔ PROPOSED COMBINATION CONCRETE CURB & GUTTER, TYPE B-6.24
(SEE HIGHWAY STANDARD 606001)
 - ㉕ PROPOSED HOT-MIX ASPHALT PAVEMENT (FULL DEPTH), 8"
(2" SURFACE COURSE, 6" BINDER COURSE) (INITIAL BINDER LIFT THICKNESS = 3.75")
 - ㉖ PROPOSED HOT-MIX ASPHALT PAVEMENT (FULL DEPTH), 10 3/4"
(2" SURFACE COURSE, 8 3/4" BINDER COURSE) (INITIAL BINDER LIFT THICKNESS = 4")
 - ㉗ PROPOSED PORTLAND CEMENT CONCRETE PAVEMENT, 8"
 - ㉘ PROPOSED HOT-MIX ASPHALT SURFACE REMOVAL, 1 1/2" AND HOT-MIX ASPHALT SURFACE COURSE, MIX D, N70, 1 1/2"
 - ㉙ PROPOSED AGGREGATE BASE COURSE, TYPE A, 8"
 - ㉚ PROPOSED COMBINATION CONCRETE CURB AND GUTTER, TYPE M-6.06
(SEE HIGHWAY STANDARD 606001)
 - ㉛ PROPOSED COMBINATION CONCRETE CURB AND GUTTER, TYPE M-6.24
(SEE HIGHWAY STANDARD 606001)
 - ㉜ PROPOSED SUBBASE GRANULAR MATERIAL, TYPE A, 10"
 - ㉝ EXISTING AGGREGATE BASE COURSE
 - ㉞ EXISTING COMBINATION CONCRETE CURB AND GUTTER, TYPE M-6.06
 - ㉟ EXISTING CONCRETE MEDIAN SURFACE
 - ㊱ EXISTING AGGREGATE SHOULDERS
 - ㊲ PROPOSED DRILL AND GROUT #6 TIE BARS
 - ㊳ EXISTING COMBINATION CONCRETE CURB AND GUTTER, TYPE M-6.12
 - ㊴ EXISTING CONTINUOUSLY REINFORCED PORTLAND CEMENT CONCRETE PAVEMENT
 - ㊵ PROPOSED HOT-MIX ASPHALT SURFACE COURSE, IL 9.5, MIX D, N70, 1 1/2"
 - ㊶ EXISTING HOT-MIX ASPHALT SURFACE
 - ㊷ EXISTING COMBINATION CONCRETE CURB AND GUTTER, TYPE B-6.24
 - ㊸ PROPOSED PIPE UNDERDRAINS, 4" (SPECIAL)
 - ㊹ PROPOSED LONGITUDINAL JOINT SEALANT
 - ㊺ PROPOSED AGGREGATE BASE COURSE, TYPE A, 12"
 - ㊻ PROPOSED HOT-MIX ASPHALT BINDER COURSE, IL 9.5FG, N70, 1 1/4"
- SEE PLAN SHEETS FOR VARIABLE HORIZONTAL DIMENSIONS.

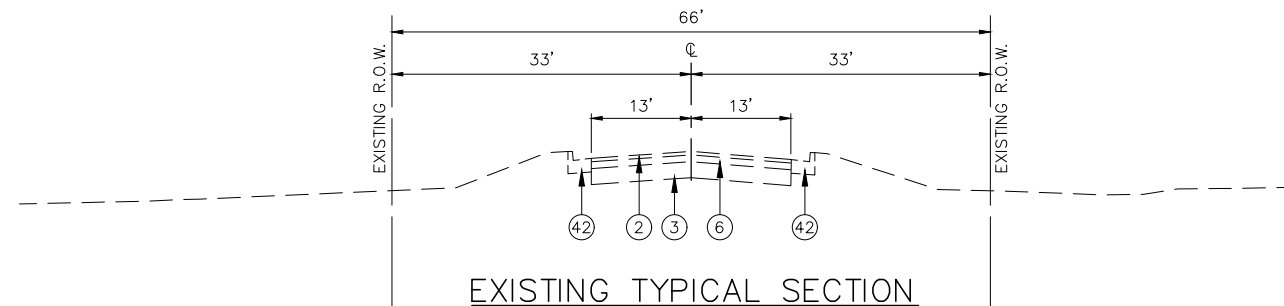

EXISTING TYPICAL SECTION

MAIN STREET

STA. 12+14.00 TO STA. 18+20.00
STA. 21+68.00 TO STA. 28+01.00
(NOT TO SCALE)

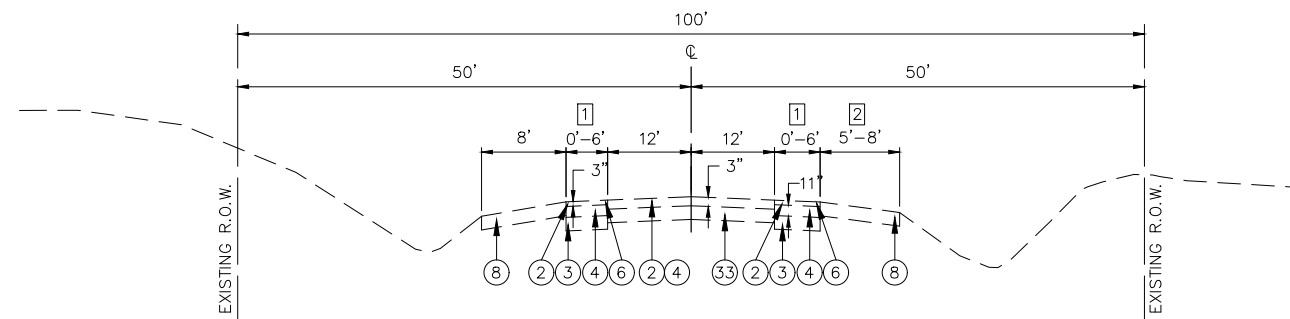

EXISTING TYPICAL SECTION

CROSS STREET

STA. 191+36.00 TO STA. 204+00.00
(NOT TO SCALE)

- ① TRANSITION FROM 6' TO 0' 193+21 TO 204+00
② TRANSITION FROM 5' TO 8' 191+36 TO 193+21

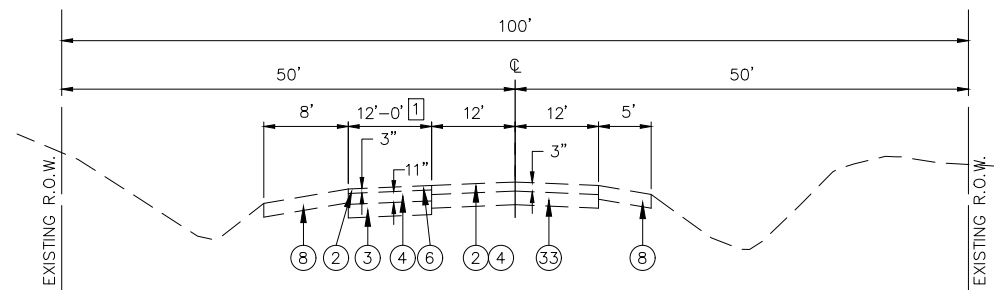

EXISTING TYPICAL SECTION

CROSS STREET

STA. 185+00.00 TO STA. 191+36.00
(NOT TO SCALE)

- ① 12' WIDE 183+00 TO 185+00
TRANSITION FROM 12' TO 0' 185+00 TO 191+36

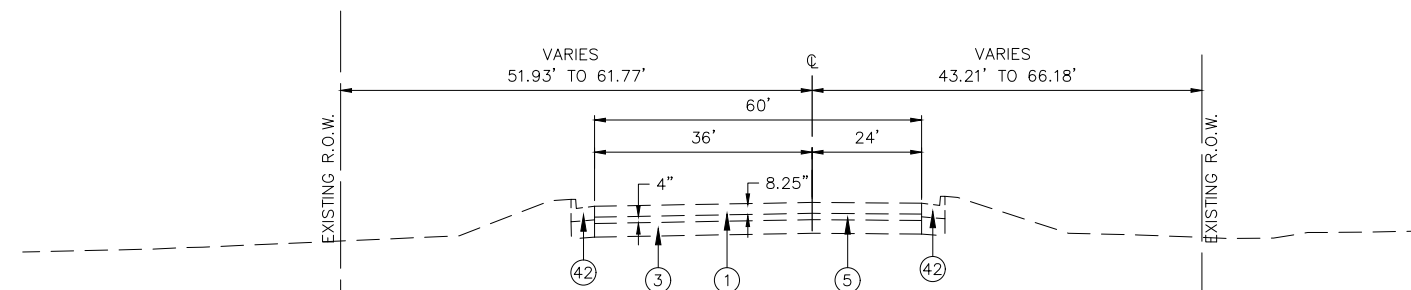

EXISTING TYPICAL SECTION

FRANK SCOTT PARKWAY EAST

STA. 159+98.16 TO STA. 161+75.87 (INTERSECTION TRANSITION)
STA. 156+29.08 TO STA. 159+98.16
(NOT TO SCALE)

F.A.U. RTE.	SECTION	COUNTY	TOTAL SHEETS	SHEET NO.
9330	95-00301-03-PV	ST. CLAIR	166	10
STA.		TO STA.		
FED. ROAD DIST. NO.		ILLINOIS FED. AID PROJECT		
FRANK SCOTT PARKWAY EAST TYPICAL SECTIONS				

CONTRACT NO.: 97372

LEGEND

- ① EXISTING P.C.C. PAVEMENT AND PAVEMENT FABRIC
 - ② EXISTING HOT-MIX ASPHALT SURFACE COURSE
 - ③ EXISTING LIME MODIFIED SOILS
 - ④ EXISTING BITUMINOUS BASE COURSE
 - ⑤ EXISTING STABILIZED SUB-BASE
 - ⑥ EXISTING HOT-MIX ASPHALT BINDER COURSE
 - ⑦ EXISTING AGGREGATE BASE WITH BITUMINOUS SURFACE TREATMENT
 - ⑧ EXISTING HOT-MIX ASPHALT SHOULDERS
 - ⑨ PROPOSED HOT-MIX ASPHALT SHOULDERS, 8"
 - ⑩ PROPOSED PROCESSING MODIFIED SOIL, 12"
 - ⑪ PROPOSED SAWED LONGITUDINAL JOINT (SEE HIGHWAY STANDARD 420001)
 - ⑫ PROPOSED LONGITUDINAL CONSTRUCTION JOINT (SEE HIGHWAY STANDARD 420001)
 - ⑬ PROPOSED SUB-BASE GRANULAR MATERIAL, TYPE A, 4"
 - ⑭ PROPOSED PORTLAND CEMENT CONCRETE PAVEMENT, 9", TYPE A FINAL FINISH
 - ⑮ PROPOSED PAVEMENT WELDED WIRE REINFORCEMENT (SEE HIGHWAY STANDARD 420701)
 - ⑯ PROPOSED AGGREGATE SHOULDER, TYPE B
 - ⑰ PROPOSED CONCRETE GUTTER, TYPE A (SEE HIGHWAY STANDARD 606101)
 - ⑱ PROPOSED CONCRETE MEDIAN SURFACE, 4" (SEE HIGHWAY STANDARD 606301)
 - ⑲ PROPOSED HOT-MIX ASPHALT SURFACE COURSE, MIX D, N70, 1 1/2"
 - ⑳ PROPOSED HOT-MIX ASPHALT BINDER COURSE, IL-19.0, N70, 2 1/4"
 - ㉑ PROPOSED HOT-MIX ASPHALT BASE COURSE, 10 1/4"
 - ㉒ PROPOSED EARTH SHOULDER
 - ㉓ PROPOSED HOT-MIX ASPHALT PAVEMENT (FULL DEPTH), 7"
(1 1/2" SURFACE COURSE, 5 1/2" BINDER COURSE) (INITIAL BINDER LIFT THICKNESS = 3")
 - ㉔ PROPOSED COMBINATION CONCRETE CURB & GUTTER, TYPE B-6.24
(SEE HIGHWAY STANDARD 606001)
 - ㉕ PROPOSED HOT-MIX ASPHALT PAVEMENT (FULL DEPTH), 8"
(2" SURFACE COURSE, 6" BINDER COURSE) (INITIAL BINDER LIFT THICKNESS = 3.75")
 - ㉖ PROPOSED HOT-MIX ASPHALT PAVEMENT (FULL DEPTH), 10 3/4"
(2" SURFACE COURSE, 8 3/4" BINDER COURSE) (INITIAL BINDER LIFT THICKNESS = 4")
 - ㉗ PROPOSED PORTLAND CEMENT CONCRETE PAVEMENT, 8"
 - ㉘ PROPOSED HOT-MIX ASPHALT SURFACE REMOVAL, 1 1/2" AND HOT-MIX ASPHALT SURFACE COURSE, MIX D, N70, 1 1/2"
 - ㉙ PROPOSED AGGREGATE BASE COURSE, TYPE A, 8"
 - ㉚ PROPOSED COMBINATION CONCRETE CURB AND GUTTER, TYPE M-6.06
(SEE HIGHWAY STANDARD 606001)
 - ㉛ PROPOSED COMBINATION CONCRETE CURB AND GUTTER, TYPE M-6.24
(SEE HIGHWAY STANDARD 606001)
 - ㉜ PROPOSED SUBBASE GRANULAR MATERIAL, TYPE A, 10"
 - ㉝ EXISTING AGGREGATE BASE COURSE
 - ㉞ EXISTING COMBINATION CONCRETE CURB AND GUTTER, TYPE M-6.06
 - ㉟ EXISTING CONCRETE MEDIAN SURFACE
 - ㊱ EXISTING AGGREGATE SHOULDERS
 - ㊲ PROPOSED DRILL AND GROUT #6 TIE BARS
 - ㊳ EXISTING COMBINATION CONCRETE CURB AND GUTTER, TYPE M-6.12
 - ㊴ EXISTING CONTINUOUSLY REINFORCED PORTLAND CEMENT CONCRETE PAVEMENT
 - ㊵ PROPOSED HOT-MIX ASPHALT SURFACE COURSE, IL 9.5, MIX D, N70, 1 1/2"
 - ㊶ EXISTING HOT-MIX ASPHALT SURFACE
 - ㊷ EXISTING COMBINATION CONCRETE CURB AND GUTTER, TYPE B-6.24
 - ㊸ PROPOSED PIPE UNDERDRAINS, 4" (SPECIAL)
 - ㊹ PROPOSED LONGITUDINAL JOINT SEALANT
 - ㊺ PROPOSED AGGREGATE BASE COURSE, TYPE A, 12"
 - ㊻ PROPOSED HOT-MIX ASPHALT BINDER COURSE, IL 9.5FG, N70, 1 1/4"
- SEE PLAN SHEETS FOR VARIABLE HORIZONTAL DIMENSIONS.

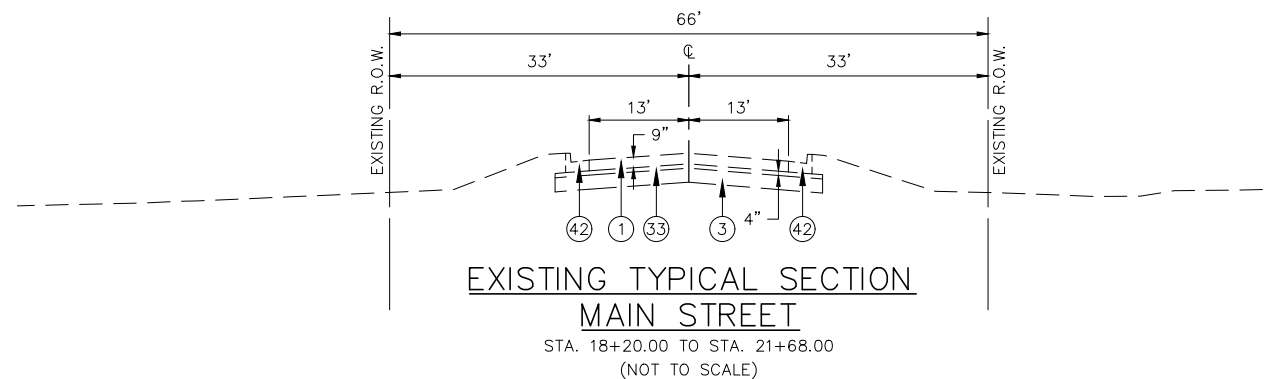
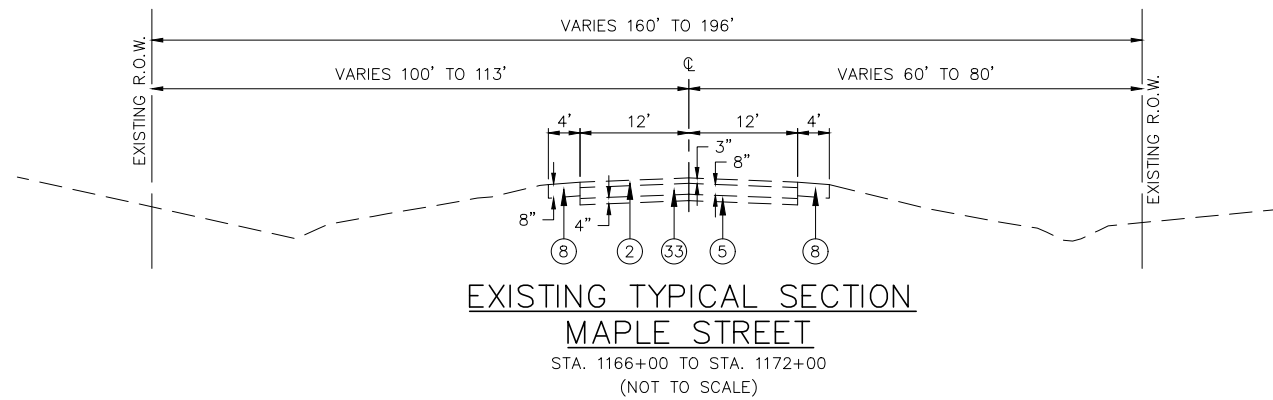
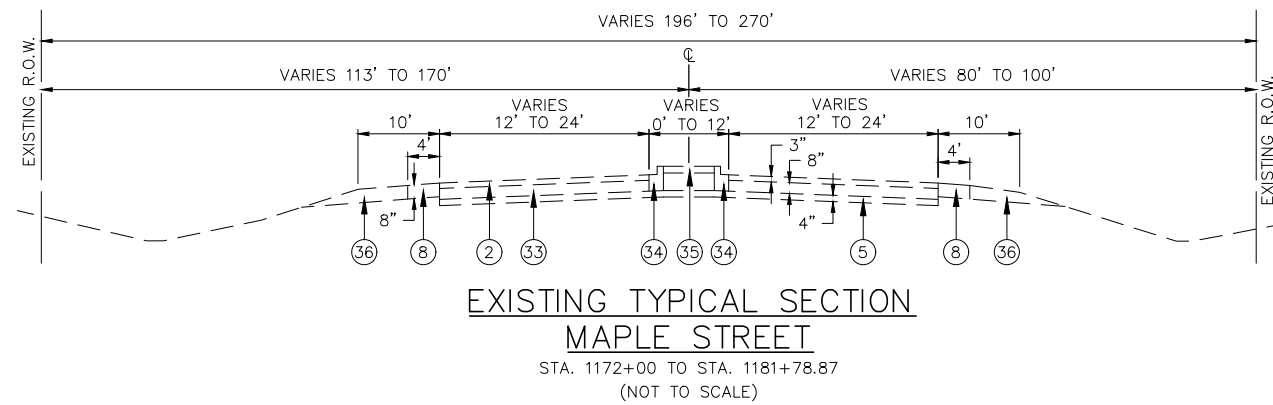
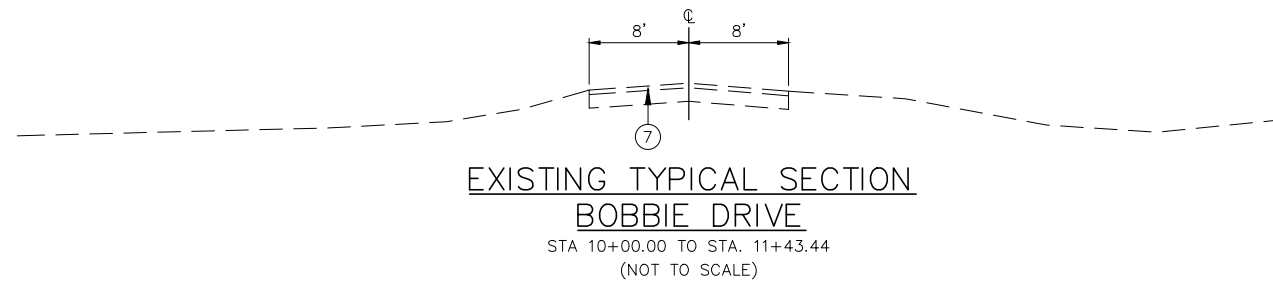
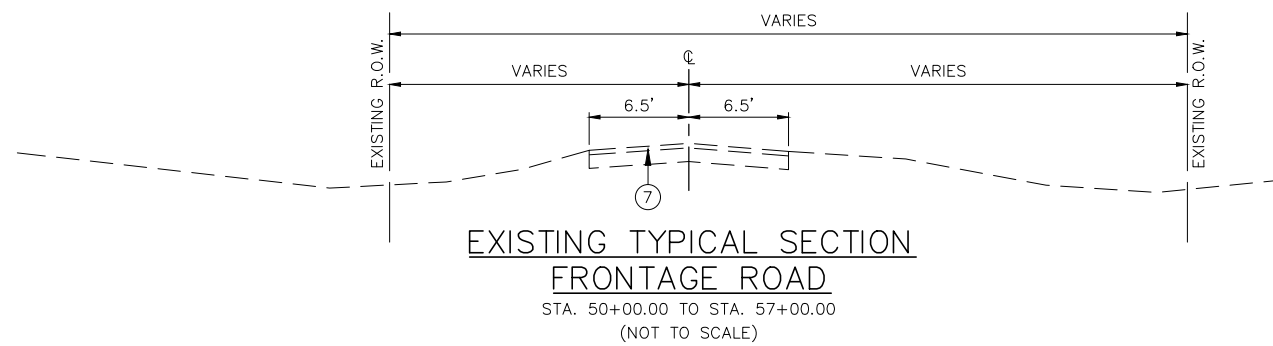

F.A.U. RTE.	SECTION	COUNTY	TOTAL SHEETS	SHEET NO.
9330	95-00301-03-PV	ST. CLAIR	166	11
STA.		TO STA.		
FED. ROAD DIST. NO.		ILLINOIS FED. AID PROJECT		
FRANK SCOTT PARKWAY EAST TYPICAL SECTIONS				
CONTRACT NO.: 97372				

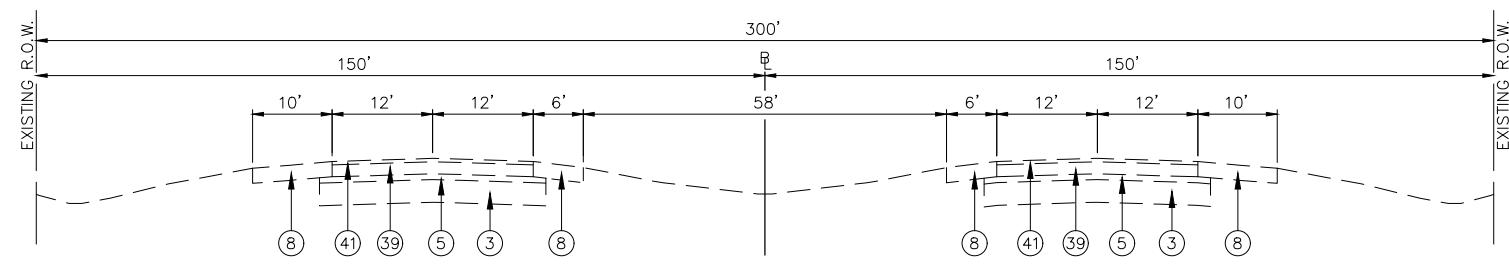

EXISTING TYPICAL SECTION
IL ROUTE 158
 STA. 201+30.09 TO STA. 213+78.92
 (NOT TO SCALE)

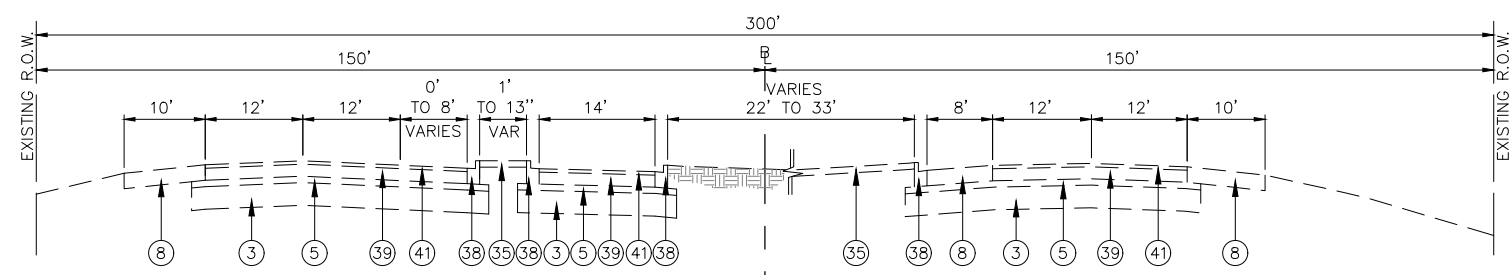

EXISTING TYPICAL SECTION
IL ROUTE 158
 STA. 197+80.53 TO STA. 201+30.09
 (NOT TO SCALE)

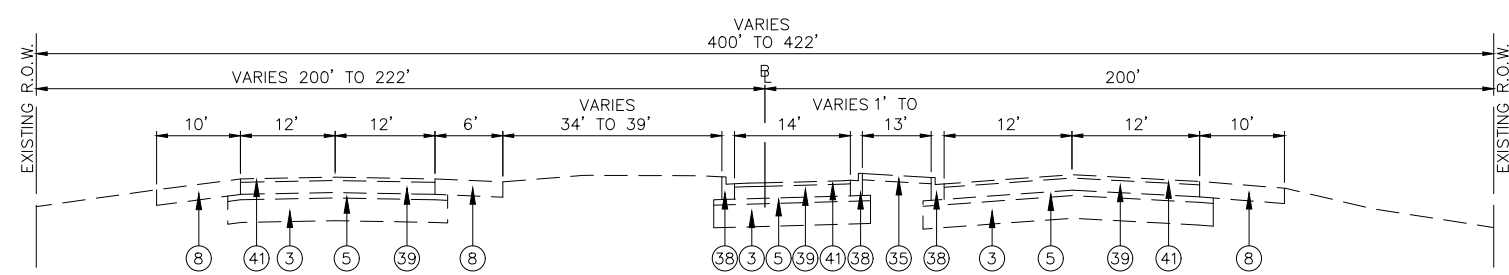

EXISTING TYPICAL SECTION
IL ROUTE 158
 STA. 192+35.96 TO STA. 197+80.53
 (NOT TO SCALE)

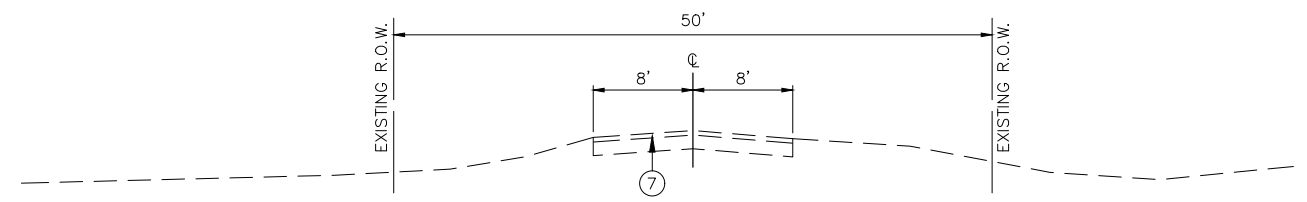

EXISTING TYPICAL SECTION
OLD O'FALLON ROAD
 (NOT TO SCALE)

LEGEND

- ① EXISTING P.C.C. PAVEMENT AND PAVEMENT FABRIC
- ② EXISTING HOT-MIX ASPHALT SURFACE COURSE
- ③ EXISTING LIME MODIFIED SOILS
- ④ EXISTING BITUMINOUS BASE COURSE
- ⑤ EXISTING STABILIZED SUB-BASE
- ⑥ EXISTING HOT-MIX ASPHALT BINDER COURSE
- ⑦ EXISTING AGGREGATE BASE WITH BITUMINOUS SURFACE TREATMENT
- ⑧ EXISTING HOT-MIX ASPHALT SHOULDERS
- ⑨ PROPOSED HOT-MIX ASPHALT SHOULDERS, 8"
- ⑩ PROPOSED PROCESSING MODIFIED SOIL, 12"
- ⑪ PROPOSED SAWED LONGITUDINAL JOINT (SEE HIGHWAY STANDARD 420001)
- ⑫ PROPOSED LONGITUDINAL CONSTRUCTION JOINT (SEE HIGHWAY STANDARD 420001)
- ⑬ PROPOSED SUB-BASE GRANULAR MATERIAL, TYPE A, 4"
- ⑭ PROPOSED PORTLAND CEMENT CONCRETE PAVEMENT, 9", TYPE A FINAL FINISH
- ⑮ PROPOSED PAVEMENT WELDED WIRE REINFORCEMENT (SEE HIGHWAY STANDARD 420701)
- ⑯ PROPOSED AGGREGATE SHOULDER, TYPE B
- ⑰ PROPOSED CONCRETE GUTTER, TYPE A (SEE HIGHWAY STANDARD 606101)
- ⑱ PROPOSED CONCRETE MEDIAN SURFACE, 4" (SEE HIGHWAY STANDARD 606301)
- ⑲ PROPOSED HOT-MIX ASPHALT SURFACE COURSE, MIX D, N70, 1 1/2"
- ⑳ PROPOSED HOT-MIX ASPHALT BINDER COURSE, IL-19.0, N70, 2 1/4"
- ㉑ PROPOSED HOT-MIX ASPHALT BASE COURSE, 10 1/4"
- ㉒ PROPOSED EARTH SHOULDER
- ㉓ PROPOSED HOT-MIX ASPHALT PAVEMENT (FULL DEPTH), 7"
(1 1/2" SURFACE COURSE, 5 1/2" BINDER COURSE) (INITIAL BINDER LIFT THICKNESS = 3")
- ㉔ PROPOSED COMBINATION CONCRETE CURB & GUTTER, TYPE B-6.24
(SEE HIGHWAY STANDARD 606001)
- ㉕ PROPOSED HOT-MIX ASPHALT PAVEMENT (FULL DEPTH), 8"
(2" SURFACE COURSE, 6" BINDER COURSE) (INITIAL BINDER LIFT THICKNESS = 3.75")
- ㉖ PROPOSED HOT-MIX ASPHALT PAVEMENT (FULL DEPTH), 10 3/4"
(2" SURFACE COURSE, 8 3/4" BINDER COURSE) (INITIAL BINDER LIFT THICKNESS = 4")
- ㉗ PROPOSED PORTLAND CEMENT CONCRETE PAVEMENT, 8"
- ㉘ PROPOSED HOT-MIX ASPHALT SURFACE REMOVAL, 1 1/2" AND HOT-MIX ASPHALT SURFACE COURSE, MIX D, N70, 1 1/2"
- ㉙ PROPOSED AGGREGATE BASE COURSE, TYPE A, 8"
- ㉚ PROPOSED COMBINATION CONCRETE CURB AND GUTTER, TYPE M-6.06
(SEE HIGHWAY STANDARD 606001)
- ㉛ PROPOSED COMBINATION CONCRETE CURB AND GUTTER, TYPE M-6.24
(SEE HIGHWAY STANDARD 606001)
- ㉜ PROPOSED SUBBASE GRANULAR MATERIAL, TYPE A, 10"
- ㉝ EXISTING AGGREGATE BASE COURSE
- ㉞ EXISTING COMBINATION CONCRETE CURB AND GUTTER, TYPE M-6.06
- ㉟ EXISTING CONCRETE MEDIAN SURFACE
- ㊱ EXISTING AGGREGATE SHOULDERS
- ㊲ PROPOSED DRILL AND GROUT #6 TIE BARS
- ㊳ EXISTING COMBINATION CONCRETE CURB AND GUTTER, TYPE M-6.12
- ㊴ EXISTING CONTINUOUSLY REINFORCED PORTLAND CEMENT CONCRETE PAVEMENT
- ㊵ PROPOSED HOT-MIX ASPHALT SURFACE COURSE, IL 9.5, MIX D, N70, 1 1/2"
- ㊶ EXISTING HOT-MIX ASPHALT SURFACE
- ㊷ EXISTING COMBINATION CONCRETE CURB AND GUTTER, TYPE B-6.24
- ㊸ PROPOSED PIPE UNDERDRAINS, 4" (SPECIAL)
- ㊹ PROPOSED LONGITUDINAL JOINT SEALANT
- ㊺ PROPOSED AGGREGATE BASE COURSE, TYPE A, 12"
- ㊻ PROPOSED HOT-MIX ASPHALT BINDER COURSE, IL 9.5FG, N70, 1 1/4"
SEE PLAN SHEETS FOR VARIABLE HORIZONTAL DIMENSIONS.

F.A.U. RTE.	SECTION	COUNTY	TOTAL SHEETS	SHEET NO.
9330	95-00301-03-PV	ST. CLAIR	166	12
STA.	TO STA.			
FED. ROAD DIST. NO.	ILLINOIS	FED. AID PROJECT		
FRANK SCOTT PARKWAY EAST TYPICAL SECTIONS				

CONTRACT NO.: 97372

LEGEND

- ① EXISTING P.C.C. PAVEMENT AND PAVEMENT FABRIC
 - ② EXISTING HOT-MIX ASPHALT SURFACE COURSE
 - ③ EXISTING LIME MODIFIED SOILS
 - ④ EXISTING BITUMINOUS BASE COURSE
 - ⑤ EXISTING STABILIZED SUB-BASE
 - ⑥ EXISTING HOT-MIX ASPHALT BINDER COURSE
 - ⑦ EXISTING AGGREGATE BASE WITH BITUMINOUS SURFACE TREATMENT
 - ⑧ EXISTING HOT-MIX ASPHALT SHOULDERS
 - ⑨ PROPOSED HOT-MIX ASPHALT SHOULDERS, 8"
 - ⑩ PROPOSED PROCESSING MODIFIED SOIL, 12"
 - ⑪ PROPOSED SAWED LONGITUDINAL JOINT (SEE HIGHWAY STANDARD 420001)
 - ⑫ PROPOSED LONGITUDINAL CONSTRUCTION JOINT (SEE HIGHWAY STANDARD 420001)
 - ⑬ PROPOSED SUB-BASE GRANULAR MATERIAL, TYPE A, 4"
 - ⑭ PROPOSED PORTLAND CEMENT CONCRETE PAVEMENT, 9", TYPE A FINAL FINISH
 - ⑮ PROPOSED PAVEMENT WELDED WIRE REINFORCEMENT (SEE HIGHWAY STANDARD 420701)
 - ⑯ PROPOSED AGGREGATE SHOULDER, TYPE B
 - ⑰ PROPOSED CONCRETE GUTTER, TYPE A (SEE HIGHWAY STANDARD 606101)
 - ⑱ PROPOSED CONCRETE MEDIAN SURFACE, 4" (SEE HIGHWAY STANDARD 606301)
 - ⑲ PROPOSED HOT-MIX ASPHALT SURFACE COURSE, MIX D, N70, 1 1/2"
 - ⑳ PROPOSED HOT-MIX ASPHALT BINDER COURSE, IL-19.0, N70, 2 1/4"
 - ㉑ PROPOSED HOT-MIX ASPHALT BASE COURSE, 10 1/4"
 - ㉒ PROPOSED EARTH SHOULDER
 - ㉓ PROPOSED HOT-MIX ASPHALT PAVEMENT (FULL DEPTH), 7" (1 1/2" SURFACE COURSE, 5 1/2" BINDER COURSE) (INITIAL BINDER LIFT THICKNESS = 3")
 - ㉔ PROPOSED COMBINATION CONCRETE CURB & GUTTER, TYPE B-6.24 (SEE HIGHWAY STANDARD 606001)
 - ㉕ PROPOSED HOT-MIX ASPHALT PAVEMENT (FULL DEPTH), 8" (2" SURFACE COURSE, 6" BINDER COURSE) (INITIAL BINDER LIFT THICKNESS = 3.75")
 - ㉖ PROPOSED HOT-MIX ASPHALT PAVEMENT (FULL DEPTH), 10 3/4" (2" SURFACE COURSE, 8 3/4" BINDER COURSE) (INITIAL BINDER LIFT THICKNESS = 4")
 - ㉗ PROPOSED PORTLAND CEMENT CONCRETE PAVEMENT, 8"
 - ㉘ PROPOSED HOT-MIX ASPHALT SURFACE REMOVAL, 1 1/2" AND HOT-MIX ASPHALT SURFACE COURSE, MIX D, N70, 1 1/2"
 - ㉙ PROPOSED AGGREGATE BASE COURSE, TYPE A, 8"
 - ㉚ PROPOSED COMBINATION CONCRETE CURB AND GUTTER, TYPE M-6.06 (SEE HIGHWAY STANDARD 606001)
 - ㉛ PROPOSED COMBINATION CONCRETE CURB AND GUTTER, TYPE M-6.24 (SEE HIGHWAY STANDARD 606001)
 - ㉜ PROPOSED SUBBASE GRANULAR MATERIAL, TYPE A, 10"
 - ㉝ EXISTING AGGREGATE BASE COURSE
 - ㉞ EXISTING COMBINATION CONCRETE CURB AND GUTTER, TYPE M-6.06
 - ㉟ EXISTING CONCRETE MEDIAN SURFACE
 - ㊱ EXISTING AGGREGATE SHOULDERS
 - ㊲ EXISTING COMBINATION CONCRETE CURB AND GUTTER, TYPE M-6.12
 - ㊳ EXISTING CONTINUOUSLY REINFORCED PORTLAND CEMENT CONCRETE PAVEMENT
 - ㊴ PROPOSED HOT-MIX ASPHALT SURFACE COURSE, IL 9.5, MIX D, N70, 1 1/2"
 - ㊵ EXISTING HOT-MIX ASPHALT SURFACE
 - ㊶ EXISTING COMBINATION CONCRETE CURB AND GUTTER, TYPE B-6.24
 - ㊷ PROPOSED PIPE UNDERDRAINS, 4" (SPECIAL)
 - ㊸ PROPOSED LONGITUDINAL JOINT SEALANT
 - ㊹ PROPOSED AGGREGATE BASE COURSE, TYPE A, 12"
 - ㊺ PROPOSED HOT-MIX ASPHALT BINDER COURSE, IL 9.5FG, N70, 1 1/4"
- SEE PLAN SHEETS FOR VARIABLE HORIZONTAL DIMENSIONS.

FRANK SCOTT PARKWAY EAST

STRUCTURAL DESIGN TRAFFIC:
 PV = 7616 SU = 779 MU = 260

ROAD/STREET CLASSIFICATION: MINOR ARTERIAL - URBAN

PERCENTAGE OF STRUCTURAL DESIGN TRAFFIC IN DESIGN LANE:
 P = 50% S = 50% M = 50%

TRAFFIC FACTOR: Actual TF = 2.70
 Year 2016
 Minimum TF = 2.54
 Class II

SUBGRADE SUPPORT RATING
 SSR = Poor (ASSUMED)

NOTE:
 MAXIMUM TRANSVERSE JOINT SPACING = 40'

SUPERELEVATION DATA	
SLOPE	STATION
TRANS. (NORMAL CROWN TO 5.80%)	140+66.20 TO 142+40.10
FULL SUPER (5.80%)	142+40.10 TO 156+70.20
TRANS. (5.80% TO NORMAL CROWN)	156+70.20 TO 158+44.10

NOTES

1. SEE CROSS SECTIONS FOR VARIABLE EARTH SLOPES.
2. SEE PLAN AND PROFILE SHEETS FOR R.O.W. WIDTHS.
3. LONGITUDINAL JOINT TIE BARS SHALL BE HELD IN THE PROPER POSITION BY SUPPORT PINS, PLACED BY APPROVED MECHANICAL MEANS, OR GROUTED-IN-PLACE. MANUAL PLACEMENT OF THE BARS WILL NOT BE ALLOWED.
4. FOR ITEM ⑭, PROPOSED P.C.C. PAVEMENT, 9", SHALL BE CONSTRUCTED WITH SAWED TRANSVERSE CONTRACTION JOINTS SPACED AT 40' IN ACCORDANCE WITH HIGHWAY STANDARD 420001.
5. SAWED CONTRACTION JOINTS SHALL BE SEALED IN ACCORDANCE WITH ARTICLE 420.12 OF THE "STANDARD SPECIFICATIONS". ANY EXCESS MATERIAL ON THE PAVEMENT SURFACE SHALL BE REMOVED IMMEDIATELY AND THE SURFACE CLEANED TO THE SATISFACTION OF THE ENGINEER.

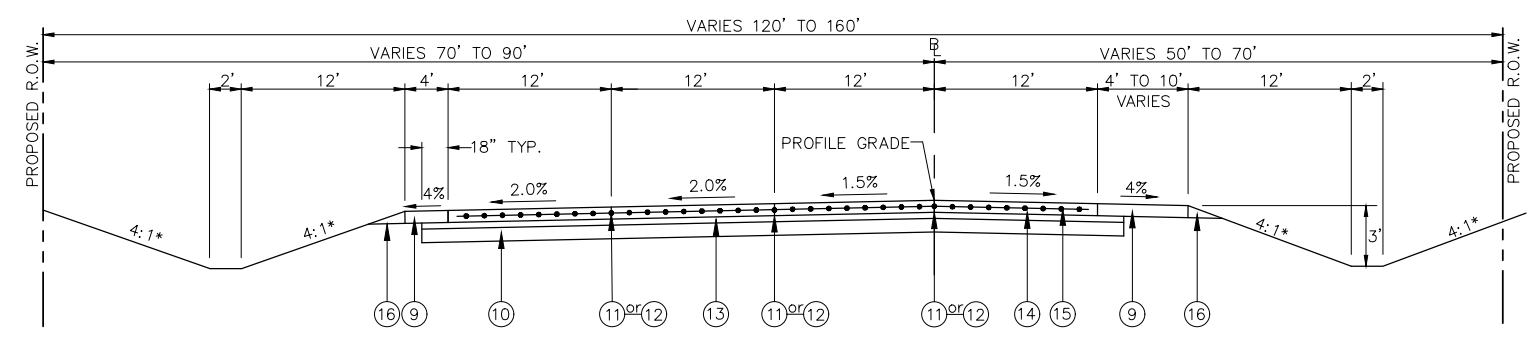

* FRONT SLOPE 0' - 25' 4:1
 OVER 25' 3:1

* BACK SLOPE UNDER 15' 4:1
 OVER 15' 3:1

PROPOSED TYPICAL SECTION FRANK SCOTT PARKWAY EAST

OMIT CROSS ST. INTERSECTION STA. 161+75.87 TO 162+13.13
 STA. 162+13.13 TO STA. 165+01.09
 (NOT TO SCALE)

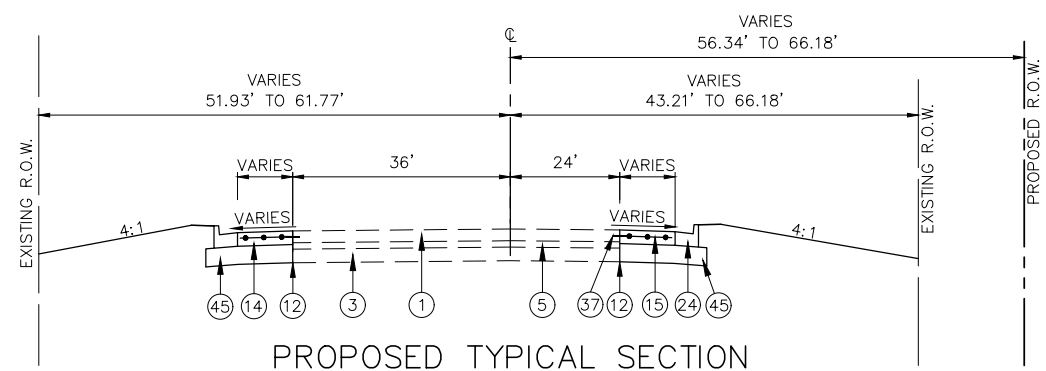

PROPOSED TYPICAL SECTION FRANK SCOTT PARKWAY EAST

STA. 160+79.62 TO STA. 161+75.87 (INTERSECTION TRANSITION)
 (NOT TO SCALE)

MIXTURE REQUIREMENTS HOT-MIX ASPHALT PROJECT

MIXTURE USE	SHOULDERS		SURFACE	BINDER	BINDER (IL RTE 158)	INCIDENTAL BIT SURF	BASE COURSE
	LOWER LIFTS	SURFACE LIFTS					
AC/PG	PG 64-22	PG 64-22	PG 64-22	PG 64-22	PG 64-22	PG 64-22	PG 64-22
DESIGN AIR VOIDS	4.0% @ Ndes=30	4.0% @ Ndes=30	4.0% @ Ndes=70	4.0% @ Ndes=70	4.0% @ Ndes=70	4.0% @ Ndes=50	4.0% @ Ndes=70
MIX COMPOSITION (GRADATION MIXTURE)	IL 19.0L	IL 9.5L		IL 19.0	IL 9.5FG		IL 19.0
FRICTION AGG			MIXTURE D	MIXTURE B	MIXTURE C	MIXTURE C	MIXTURE B

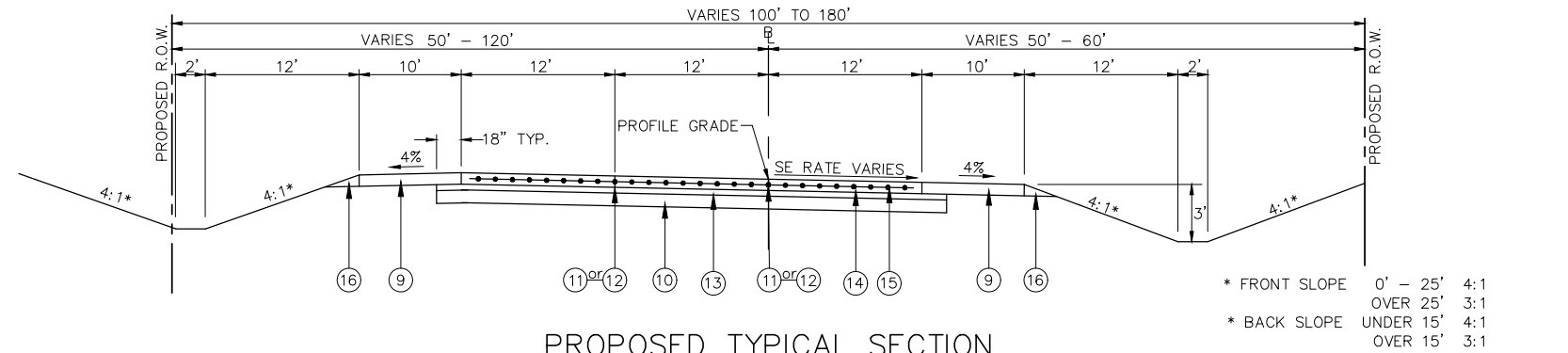

**PROPOSED TYPICAL SECTION
FRANK SCOTT PARKWAY EAST**
STA. 175+20.26 TO STA. 177+91.00
(NOT TO SCALE)

SUPERELEVATION DATA	
SLOPE	STATION
TRANS. (NORMAL CROWN TO 2.90%)	175+20.26 TO 176+80.26
FULL SUPER (2.90%)	176+80.26 TO 196+68.61
TRANS. (2.90% TO NORMAL CROWN)	196+68.61 TO 198+28.61

* FRONT SLOPE 0' - 25' 4:1
OVER 25' 3:1
* BACK SLOPE UNDER 15' 4:1
OVER 15' 3:1

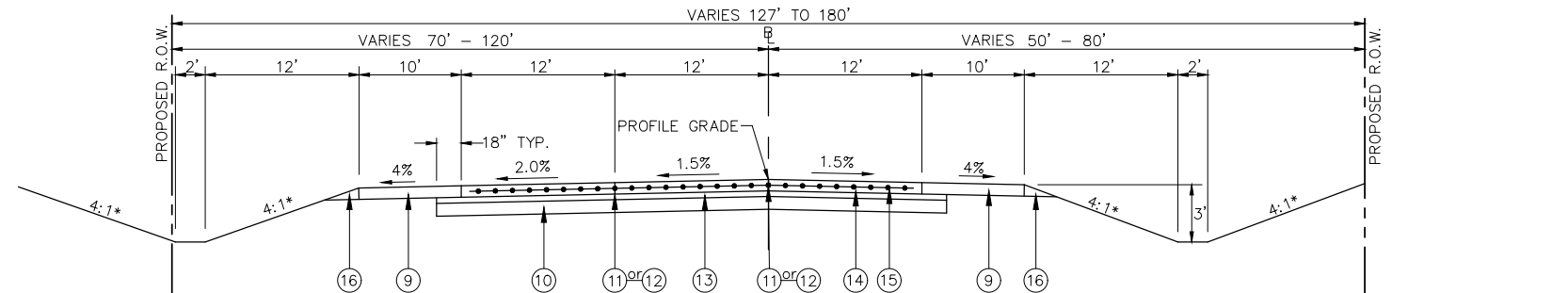

**PROPOSED TYPICAL SECTION
FRANK SCOTT PARKWAY EAST**
STA. 167+21.09 TO STA. 175+20.26
(NOT TO SCALE)

* FRONT SLOPE 0' - 25' 4:1
OVER 25' 3:1
* BACK SLOPE UNDER 15' 4:1
OVER 15' 3:1

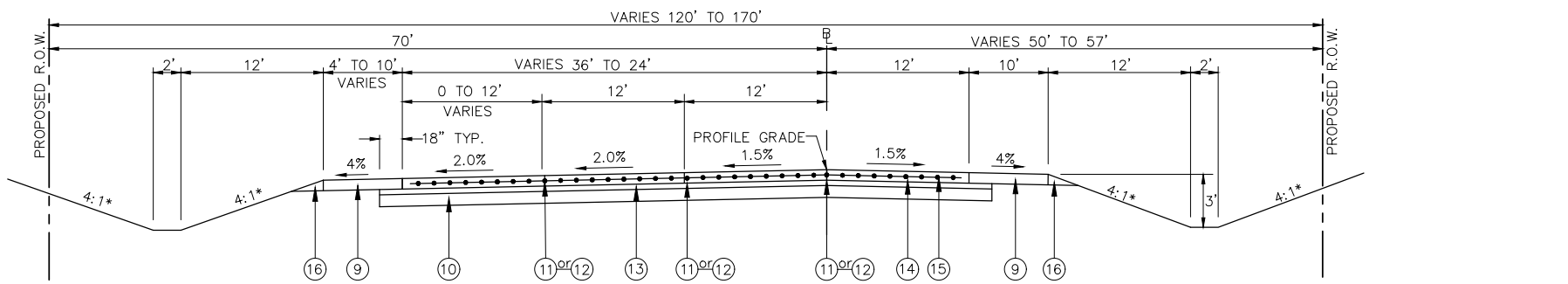

**PROPOSED TYPICAL SECTION
FRANK SCOTT PARKWAY EAST**
STA. 165+01.09 TO STA. 167+21.09
(NOT TO SCALE)

* FRONT SLOPE 0' - 25' 4:1
OVER 25' 3:1
* BACK SLOPE UNDER 15' 4:1
OVER 15' 3:1

LEGEND

- ① EXISTING P.C.C. PAVEMENT AND PAVEMENT FABRIC
 - ② EXISTING HOT-MIX ASPHALT SURFACE COURSE
 - ③ EXISTING LIME MODIFIED SOILS
 - ④ EXISTING BITUMINOUS BASE COURSE
 - ⑤ EXISTING STABILIZED SUB-BASE
 - ⑥ EXISTING HOT-MIX ASPHALT BINDER COURSE
 - ⑦ EXISTING AGGREGATE BASE WITH BITUMINOUS SURFACE TREATMENT
 - ⑧ EXISTING HOT-MIX ASPHALT SHOULDERS
 - ⑨ PROPOSED HOT-MIX ASPHALT SHOULDERS, 8"
 - ⑩ PROPOSED PROCESSING MODIFIED SOIL, 12"
 - ⑪ PROPOSED SAWED LONGITUDINAL JOINT (SEE HIGHWAY STANDARD 420001)
 - ⑫ PROPOSED LONGITUDINAL CONSTRUCTION JOINT (SEE HIGHWAY STANDARD 420001)
 - ⑬ PROPOSED SUB-BASE GRANULAR MATERIAL, TYPE A, 4"
 - ⑭ PROPOSED PORTLAND CEMENT CONCRETE PAVEMENT, 9", TYPE A FINAL FINISH
 - ⑮ PROPOSED PAVEMENT WELDED WIRE REINFORCEMENT (SEE HIGHWAY STANDARD 420701)
 - ⑯ PROPOSED AGGREGATE SHOULDER, TYPE B
 - ⑰ PROPOSED CONCRETE GUTTER, TYPE A (SEE HIGHWAY STANDARD 606101)
 - ⑱ PROPOSED CONCRETE MEDIAN SURFACE, 4" (SEE HIGHWAY STANDARD 606301)
 - ⑲ PROPOSED HOT-MIX ASPHALT SURFACE COURSE, MIX D, N70, 1 1/2"
 - ⑳ PROPOSED HOT-MIX ASPHALT BINDER COURSE, IL-19.0, N70, 2 1/4"
 - ㉑ PROPOSED HOT-MIX ASPHALT BASE COURSE, 10 1/4"
 - ㉒ PROPOSED EARTH SHOULDER
 - ㉓ PROPOSED HOT-MIX ASPHALT PAVEMENT (FULL DEPTH), 7" (1 1/2" SURFACE COURSE, 5 1/2" BINDER COURSE) (INITIAL BINDER LIFT THICKNESS = 3")
 - ㉔ PROPOSED COMBINATION CONCRETE CURB & GUTTER, TYPE B-6.24 (SEE HIGHWAY STANDARD 606001)
 - ㉕ PROPOSED HOT-MIX ASPHALT PAVEMENT (FULL DEPTH), 8" (2" SURFACE COURSE, 6" BINDER COURSE) (INITIAL BINDER LIFT THICKNESS = 3.75")
 - ㉖ PROPOSED HOT-MIX ASPHALT PAVEMENT (FULL DEPTH), 10 3/4" (2" SURFACE COURSE, 8 3/4" BINDER COURSE) (INITIAL BINDER LIFT THICKNESS = 4")
 - ㉗ PROPOSED PORTLAND CEMENT CONCRETE PAVEMENT, 8"
 - ㉘ PROPOSED HOT-MIX ASPHALT SURFACE REMOVAL, 1 1/2" AND HOT-MIX ASPHALT SURFACE COURSE, MIX D, N70, 1 1/2"
 - ㉙ PROPOSED AGGREGATE BASE COURSE, TYPE A, 8"
 - ㉚ PROPOSED COMBINATION CONCRETE CURB AND GUTTER, TYPE M-6.06 (SEE HIGHWAY STANDARD 606001)
 - ㉛ PROPOSED COMBINATION CONCRETE CURB AND GUTTER, TYPE M-6.24 (SEE HIGHWAY STANDARD 606001)
 - ㉜ PROPOSED SUBBASE GRANULAR MATERIAL, TYPE A, 10"
 - ㉝ EXISTING AGGREGATE BASE COURSE
 - ㉞ EXISTING COMBINATION CONCRETE CURB AND GUTTER, TYPE M-6.06
 - ㉟ EXISTING CONCRETE MEDIAN SURFACE
 - ㊱ EXISTING AGGREGATE SHOULDERS
 - ㊲ PROPOSED DRILL AND GROUT #6 TIE BARS
 - ㊳ EXISTING COMBINATION CONCRETE CURB AND GUTTER, TYPE M-6.12
 - ㊴ EXISTING CONTINUOUSLY REINFORCED PORTLAND CEMENT CONCRETE PAVEMENT
 - ㊵ PROPOSED HOT-MIX ASPHALT SURFACE COURSE, IL 9.5, MIX D, N70, 1 1/2"
 - ㊶ EXISTING HOT-MIX ASPHALT SURFACE
 - ㊷ EXISTING COMBINATION CONCRETE CURB AND GUTTER, TYPE B-6.24
 - ㊸ PROPOSED PIPE UNDERDRAINS, 4" (SPECIAL)
 - ㊹ PROPOSED LONGITUDINAL JOINT SEALANT
 - ㊺ PROPOSED AGGREGATE BASE COURSE, TYPE A, 12"
 - ㊻ PROPOSED HOT-MIX ASPHALT BINDER COURSE, IL 9.5FG, N70, 1 1/4"
- SEE PLAN SHEETS FOR VARIABLE HORIZONTAL DIMENSIONS.

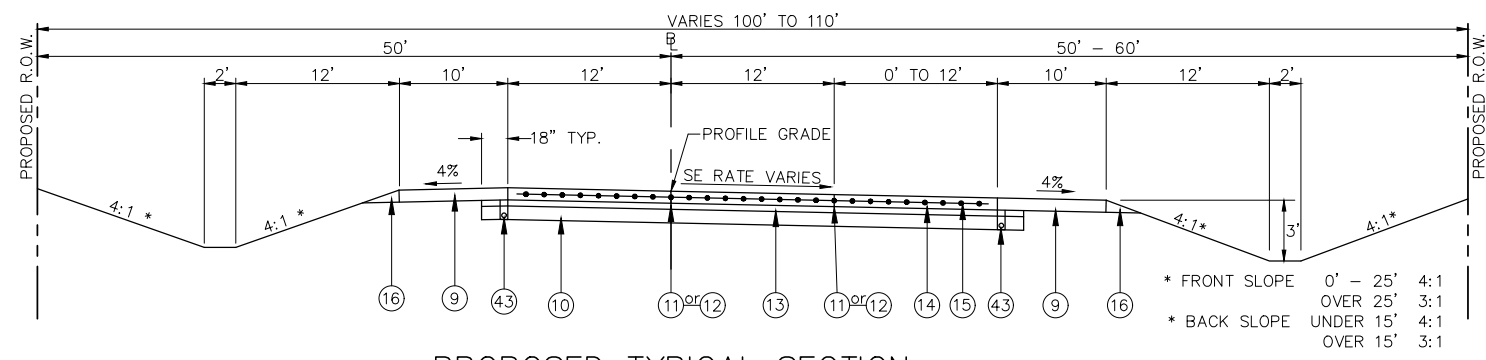

**PROPOSED TYPICAL SECTION
FRANK SCOTT PARKWAY EAST**

STA. 189+73.93 TO STA. 194+53.97
(NOT TO SCALE)

* FRONT SLOPE 0' - 25' 4:1
OVER 25' 3:1
* BACK SLOPE UNDER 15' 4:1
OVER 15' 3:1

SUPERELEVATION DATA	
SLOPE	STATION
TRANS. (NORMAL CROWN TO 2.90%)	175+20.26 TO 176+80.26
FULL SUPER (2.90%)	176+80.26 TO 196+68.61
TRANS. (2.90% TO NORMAL CROWN)	196+68.61 TO 198+28.61

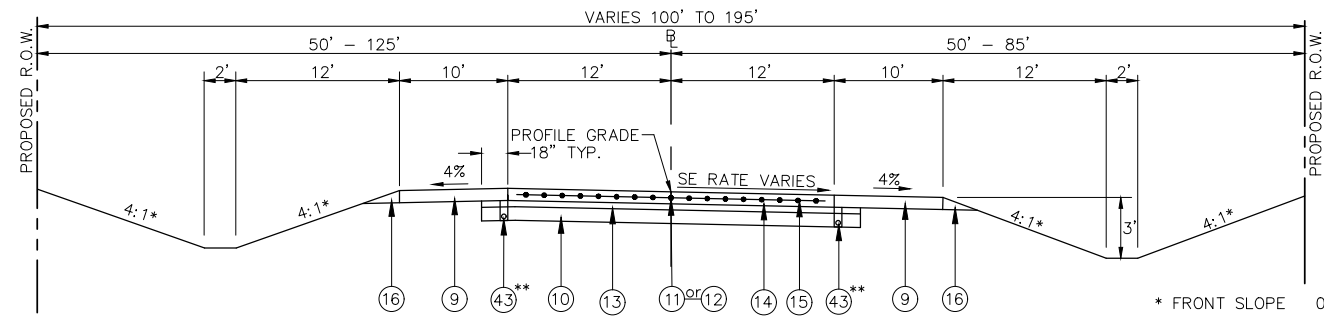

**PROPOSED TYPICAL SECTION
FRANK SCOTT PARKWAY EAST**

STA. 182+71.00 TO STA. 189+73.93
(NOT TO SCALE)

* FRONT SLOPE 0' - 25' 4:1
OVER 25' 3:1
* BACK SLOPE UNDER 15' 4:1
OVER 15' 3:1
** START PIPE UNDERDRAIN AT 185+00

SUPERELEVATION DATA	
SLOPE	STATION
TRANS. (NORMAL CROWN TO 2.90%)	175+20.26 TO 176+80.26
FULL SUPER (2.90%)	176+80.26 TO 196+68.61
TRANS. (2.90% TO NORMAL CROWN)	196+68.61 TO 198+28.61

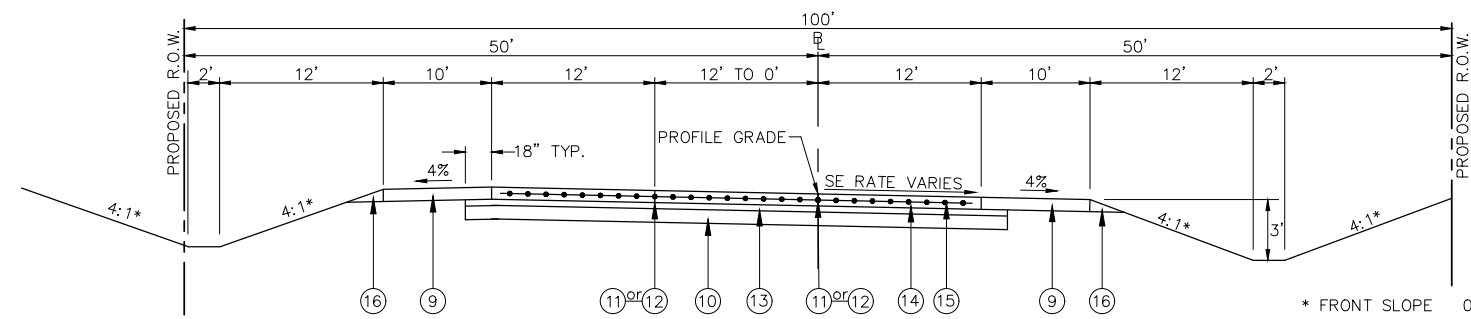

**PROPOSED TYPICAL SECTION FRANK SCOTT
PARKWAY EAST**

STA. 177+91.00 TO STA. 182+71.00
(NOT TO SCALE)

* FRONT SLOPE 0' - 25' 4:1
OVER 25' 3:1
* BACK SLOPE UNDER 15' 4:1
OVER 15' 3:1

SUPERELEVATION DATA	
SLOPE	STATION
TRANS. (NORMAL CROWN TO 2.90%)	175+20.26 TO 176+80.26
FULL SUPER (2.90%)	176+80.26 TO 196+68.61
TRANS. (2.90% TO NORMAL CROWN)	196+68.61 TO 198+28.61

LEGEND

- ① EXISTING P.C.C. PAVEMENT AND PAVEMENT FABRIC
- ② EXISTING HOT-MIX ASPHALT SURFACE COURSE
- ③ EXISTING LIME MODIFIED SOILS
- ④ EXISTING BITUMINOUS BASE COURSE
- ⑤ EXISTING STABILIZED SUB-BASE
- ⑥ EXISTING HOT-MIX ASPHALT BINDER COURSE
- ⑦ EXISTING AGGREGATE BASE WITH BITUMINOUS SURFACE TREATMENT
- ⑧ EXISTING HOT-MIX ASPHALT SHOULDERS
- ⑨ PROPOSED HOT-MIX ASPHALT SHOULDERS, 8"
- ⑩ PROPOSED PROCESSING MODIFIED SOIL, 12"
- ⑪ PROPOSED SAWED LONGITUDINAL JOINT (SEE HIGHWAY STANDARD 420001)
- ⑫ PROPOSED LONGITUDINAL CONSTRUCTION JOINT (SEE HIGHWAY STANDARD 420001)
- ⑬ PROPOSED SUB-BASE GRANULAR MATERIAL, TYPE A, 4"
- ⑭ PROPOSED PORTLAND CEMENT CONCRETE PAVEMENT, 9", TYPE A FINAL FINISH
- ⑮ PROPOSED PAVEMENT WELDED WIRE REINFORCEMENT (SEE HIGHWAY STANDARD 420701)
- ⑯ PROPOSED AGGREGATE SHOULDER, TYPE B
- ⑰ PROPOSED CONCRETE GUTTER, TYPE A (SEE HIGHWAY STANDARD 606101)
- ⑱ PROPOSED CONCRETE MEDIAN SURFACE, 4" (SEE HIGHWAY STANDARD 606301)
- ⑲ PROPOSED HOT-MIX ASPHALT SURFACE COURSE, MIX D, N70, 1 1/2"
- ⑳ PROPOSED HOT-MIX ASPHALT BINDER COURSE, IL-19.0, N70, 2 1/4"
- ㉑ PROPOSED HOT-MIX ASPHALT BASE COURSE, 10 1/4"
- ㉒ PROPOSED EARTH SHOULDER
- ㉓ PROPOSED HOT-MIX ASPHALT PAVEMENT (FULL DEPTH), 7"
(1 1/2" SURFACE COURSE, 5 1/2" BINDER COURSE) (INITIAL BINDER LIFT THICKNESS = 3")
- ㉔ PROPOSED COMBINATION CONCRETE CURB & GUTTER, TYPE B-6.24
(SEE HIGHWAY STANDARD 606001)
- ㉕ PROPOSED HOT-MIX ASPHALT PAVEMENT (FULL DEPTH), 8"
(2" SURFACE COURSE, 6" BINDER COURSE) (INITIAL BINDER LIFT THICKNESS = 3.75")
- ㉖ PROPOSED HOT-MIX ASPHALT PAVEMENT (FULL DEPTH), 10 3/4"
(2" SURFACE COURSE, 8 3/4" BINDER COURSE) (INITIAL BINDER LIFT THICKNESS = 4")
- ㉗ PROPOSED PORTLAND CEMENT CONCRETE PAVEMENT, 8"
- ㉘ PROPOSED HOT-MIX ASPHALT SURFACE REMOVAL, 1 1/2" AND HOT-MIX ASPHALT SURFACE COURSE, MIX D, N70, 1 1/2"
- ㉙ PROPOSED AGGREGATE BASE COURSE, TYPE A, 8"
- ㉚ PROPOSED COMBINATION CONCRETE CURB AND GUTTER, TYPE M-6.06
(SEE HIGHWAY STANDARD 606001)
- ㉛ PROPOSED COMBINATION CONCRETE CURB AND GUTTER, TYPE M-6.24
(SEE HIGHWAY STANDARD 606001)
- ㉜ PROPOSED SUBBASE GRANULAR MATERIAL, TYPE A, 10"
- ㉝ EXISTING AGGREGATE BASE COURSE
- ㉞ EXISTING COMBINATION CONCRETE CURB AND GUTTER, TYPE M-6.06
- ㉟ EXISTING CONCRETE MEDIAN SURFACE
- ㊱ EXISTING AGGREGATE SHOULDERS
- ㊲ PROPOSED DRILL AND GROUT #6 TIE BARS
- ㊳ EXISTING COMBINATION CONCRETE CURB AND GUTTER, TYPE M-6.12
- ㊴ EXISTING CONTINUOUSLY REINFORCED PORTLAND CEMENT CONCRETE PAVEMENT
- ㊵ PROPOSED HOT-MIX ASPHALT SURFACE COURSE, IL 9.5, MIX D, N70, 1 1/2"
- ㊶ EXISTING HOT-MIX ASPHALT SURFACE
- ㊷ EXISTING COMBINATION CONCRETE CURB AND GUTTER, TYPE B-6.24
- ㊸ PROPOSED PIPE UNDERDRAINS, 4" (SPECIAL)
- ㊹ PROPOSED LONGITUDINAL JOINT SEALANT
- ㊺ PROPOSED AGGREGATE BASE COURSE, TYPE A, 12"
- ㊻ PROPOSED HOT-MIX ASPHALT BINDER COURSE, IL 9.5FG, N70, 1 1/4"
SEE PLAN SHEETS FOR VARIABLE HORIZONTAL DIMENSIONS.

F.A.U. RTE.	SECTION	COUNTY	TOTAL SHEETS	SHEET NO.
9330	95-00301-03-PV	ST. CLAIR	166	15
STA.	TO STA.			
FED. ROAD DIST. NO.	ILLINOIS	FED. AID PROJECT		
FRANK SCOTT PARKWAY EAST TYPICAL SECTIONS				

CONTRACT NO.: 97372

LEGEND

- ① EXISTING P.C.C. PAVEMENT AND PAVEMENT FABRIC
 - ② EXISTING HOT-MIX ASPHALT SURFACE COURSE
 - ③ EXISTING LIME MODIFIED SOILS
 - ④ EXISTING BITUMINOUS BASE COURSE
 - ⑤ EXISTING STABILIZED SUB-BASE
 - ⑥ EXISTING HOT-MIX ASPHALT BINDER COURSE
 - ⑦ EXISTING AGGREGATE BASE WITH BITUMINOUS SURFACE TREATMENT
 - ⑧ EXISTING HOT-MIX ASPHALT SHOULDERS
 - ⑨ PROPOSED HOT-MIX ASPHALT SHOULDERS, 8"
 - ⑩ PROPOSED PROCESSING MODIFIED SOIL, 12"
 - ⑪ PROPOSED SAWED LONGITUDINAL JOINT (SEE HIGHWAY STANDARD 420001)
 - ⑫ PROPOSED LONGITUDINAL CONSTRUCTION JOINT (SEE HIGHWAY STANDARD 420001)
 - ⑬ PROPOSED SUB-BASE GRANULAR MATERIAL, TYPE A, 4"
 - ⑭ PROPOSED PORTLAND CEMENT CONCRETE PAVEMENT, 9", TYPE A FINAL FINISH
 - ⑮ PROPOSED PAVEMENT WELDED WIRE REINFORCEMENT (SEE HIGHWAY STANDARD 420701)
 - ⑯ PROPOSED AGGREGATE SHOULDER, TYPE B
 - ⑰ PROPOSED CONCRETE GUTTER, TYPE A (SEE HIGHWAY STANDARD 606101)
 - ⑱ PROPOSED CONCRETE MEDIAN SURFACE, 4" (SEE HIGHWAY STANDARD 606301)
 - ⑲ PROPOSED HOT-MIX ASPHALT SURFACE COURSE, MIX D, N70, 1 1/2"
 - ⑳ PROPOSED HOT-MIX ASPHALT BINDER COURSE, IL-19.0, N70, 2 1/4"
 - ㉑ PROPOSED HOT-MIX ASPHALT BASE COURSE, 10 1/4"
 - ㉒ PROPOSED EARTH SHOULDER
 - ㉓ PROPOSED HOT-MIX ASPHALT PAVEMENT (FULL DEPTH), 7" (1 1/2" SURFACE COURSE, 5 1/2" BINDER COURSE) (INITIAL BINDER LIFT THICKNESS = 3")
 - ㉔ PROPOSED COMBINATION CONCRETE CURB & GUTTER, TYPE B-6.24 (SEE HIGHWAY STANDARD 606001)
 - ㉕ PROPOSED HOT-MIX ASPHALT PAVEMENT (FULL DEPTH), 8" (2" SURFACE COURSE, 6" BINDER COURSE) (INITIAL BINDER LIFT THICKNESS = 3.75")
 - ㉖ PROPOSED HOT-MIX ASPHALT PAVEMENT (FULL DEPTH), 10 3/4" (2" SURFACE COURSE, 8 3/4" BINDER COURSE) (INITIAL BINDER LIFT THICKNESS = 4")
 - ㉗ PROPOSED PORTLAND CEMENT CONCRETE PAVEMENT, 8"
 - ㉘ PROPOSED HOT-MIX ASPHALT SURFACE REMOVAL, 1 1/2" AND HOT-MIX ASPHALT SURFACE COURSE, MIX D, N70, 1 1/2"
 - ㉙ PROPOSED AGGREGATE BASE COURSE, TYPE A, 8"
 - ㉚ PROPOSED COMBINATION CONCRETE CURB AND GUTTER, TYPE M-6.06 (SEE HIGHWAY STANDARD 606001)
 - ㉛ PROPOSED COMBINATION CONCRETE CURB AND GUTTER, TYPE M-6.24 (SEE HIGHWAY STANDARD 606001)
 - ㉜ PROPOSED SUBBASE GRANULAR MATERIAL, TYPE A, 10"
 - ㉝ EXISTING AGGREGATE BASE COURSE
 - ㉞ EXISTING COMBINATION CONCRETE CURB AND GUTTER, TYPE M-6.06
 - ㉟ EXISTING CONCRETE MEDIAN SURFACE
 - ㊱ EXISTING AGGREGATE SHOULDERS
 - ㊲ PROPOSED DRILL AND GROUT #6 TIE BARS
 - ㊳ EXISTING COMBINATION CONCRETE CURB AND GUTTER, TYPE M-6.12
 - ㊴ EXISTING CONTINUOUSLY REINFORCED PORTLAND CEMENT CONCRETE PAVEMENT
 - ㊵ PROPOSED HOT-MIX ASPHALT SURFACE COURSE, IL 9.5, MIX D, N70, 1 1/2"
 - ㊶ EXISTING HOT-MIX ASPHALT SURFACE
 - ㊷ EXISTING COMBINATION CONCRETE CURB AND GUTTER, TYPE B-6.24
 - ㊸ PROPOSED PIPE UNDERDRAINS, 4" (SPECIAL)
 - ㊹ PROPOSED LONGITUDINAL JOINT SEALANT
 - ㊺ PROPOSED AGGREGATE BASE COURSE, TYPE A, 12"
 - ㊻ PROPOSED HOT-MIX ASPHALT BINDER COURSE, IL 9.5FG, N70, 1 1/4"
- SEE PLAN SHEETS FOR VARIABLE HORIZONTAL DIMENSIONS.

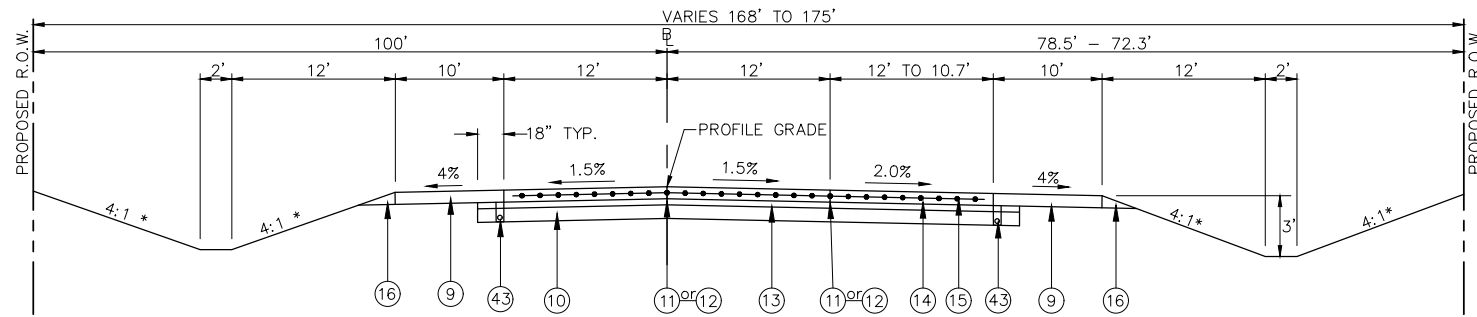

**PROPOSED TYPICAL SECTION
FRANK SCOTT PARKWAY EAST**

STA. 205+39.89 TO STA. 205+92.36
(NOT TO SCALE)

* FRONT SLOPE 0' - 25' 4:1
OVER 25' 3:1
* BACK SLOPE UNDER 15' 4:1
OVER 15' 3:1

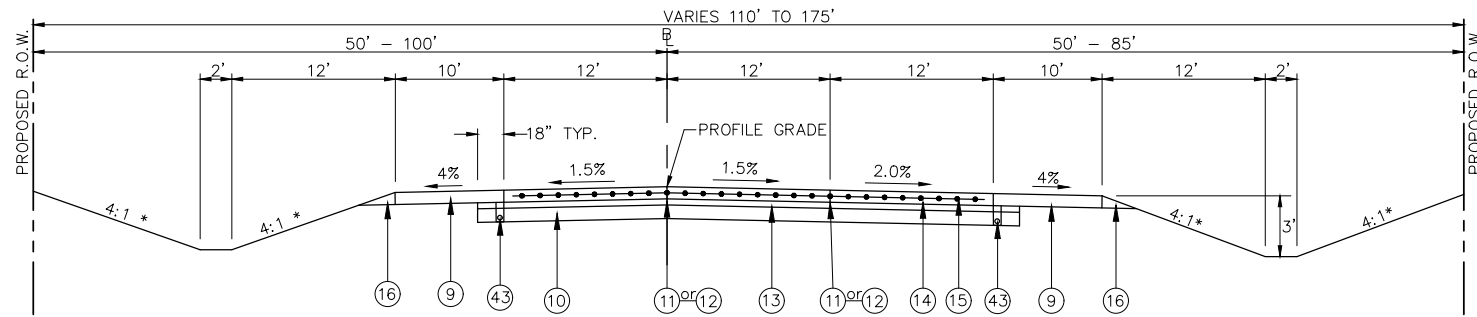

**PROPOSED TYPICAL SECTION
FRANK SCOTT PARKWAY EAST**

STA. 198+28.61 TO STA. 205+39.89
OMIT MAIN ST. INTERSECTION STA. 200+71.15 TO STA. 200+97.99
(NOT TO SCALE)

* FRONT SLOPE 0' - 25' 4:1
OVER 25' 3:1
* BACK SLOPE UNDER 15' 4:1
OVER 15' 3:1

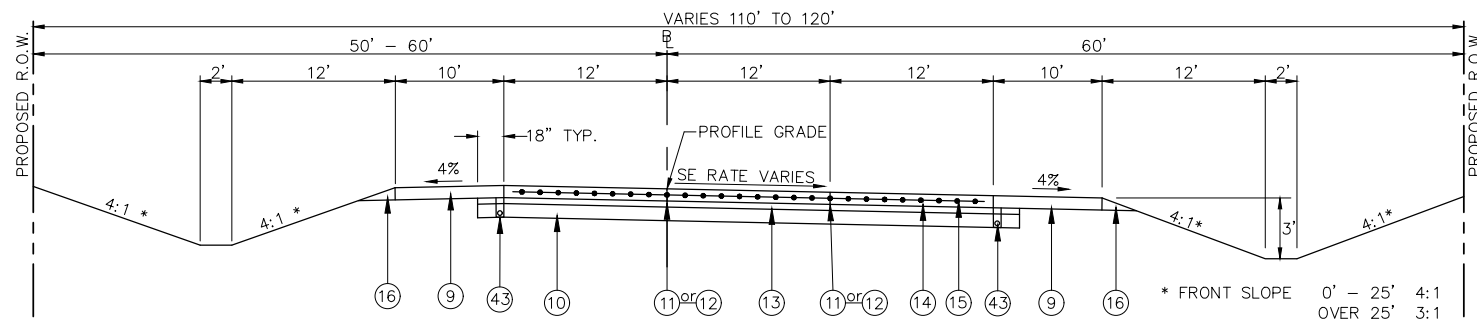

**PROPOSED TYPICAL SECTION
FRANK SCOTT PARKWAY EAST**

STA. 194+53.97 TO STA. 198+28.61
(NOT TO SCALE)

* FRONT SLOPE 0' - 25' 4:1
OVER 25' 3:1
* BACK SLOPE UNDER 15' 4:1
OVER 15' 3:1

SUPERELEVATION DATA	
SLOPE	STATION
TRANS. (NORMAL CROWN TO 2.90%)	175+20.26 TO 176+80.26
FULL SUPER (2.90%)	176+80.26 TO 196+68.61
TRANS. (2.90% TO NORMAL CROWN)	196+68.61 TO 198+28.61

F.A.U. RTE.	SECTION	COUNTY	TOTAL SHEETS	SHEET NO.
9330	95-00301-03-PV	ST. CLAIR	166	16
STA.		TO STA.		
FED. ROAD DIST. NO.	ILLINOIS	FED. AID PROJECT		
FRANK SCOTT PARKWAY EAST TYPICAL SECTIONS				
CONTRACT NO.: 97372				

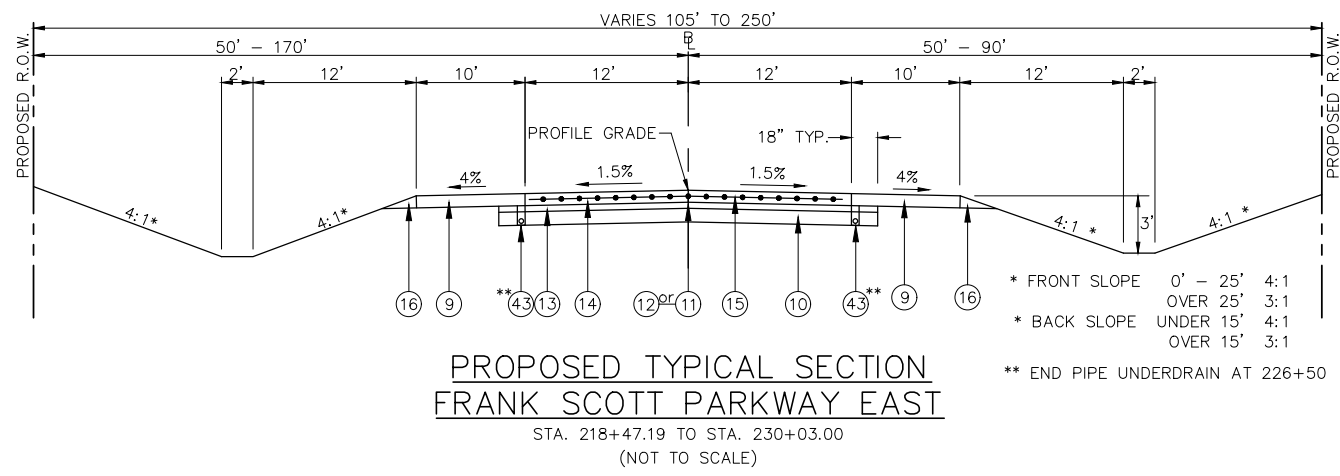

* FRONT SLOPE 0' - 25' 4:1
OVER 25' 3:1
* BACK SLOPE UNDER 15' 4:1
OVER 15' 3:1
** END PIPE UNDERDRAIN AT 226+50

**PROPOSED TYPICAL SECTION
FRANK SCOTT PARKWAY EAST**
STA. 218+47.19 TO STA. 230+03.00
(NOT TO SCALE)

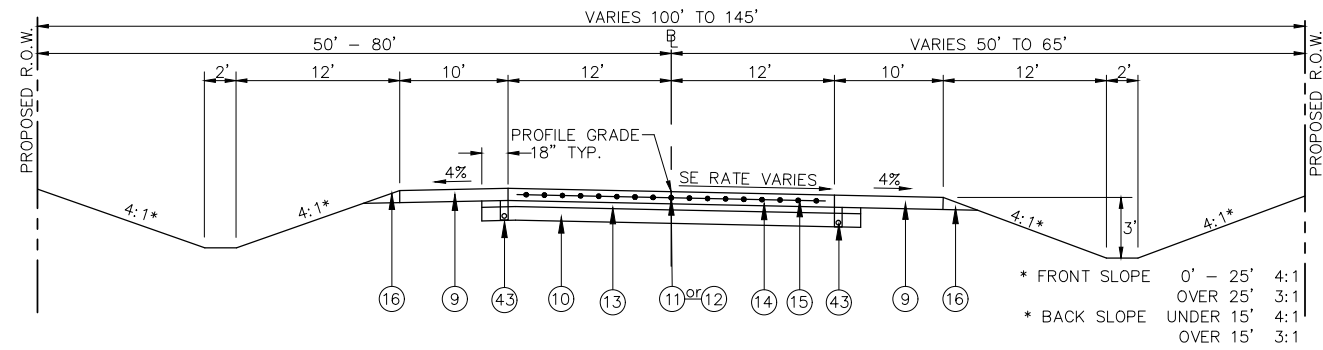

* FRONT SLOPE 0' - 25' 4:1
OVER 25' 3:1
* BACK SLOPE UNDER 15' 4:1
OVER 15' 3:1

**PROPOSED TYPICAL SECTION
FRANK SCOTT PARKWAY EAST**
STA. 210+19.91 TO STA. 218+47.19
(NOT TO SCALE)

SUPERELEVATION DATA	
SLOPE	STATION
TRANS. (NORMAL CROWN TO 4.00%)	205+92.36 TO 207+24.36
FULL SUPER (4.00%)	207+24.36 TO 217+15.19
TRANS. (4.00% TO NORMAL CROWN)	217+15.19 TO 218+47.19

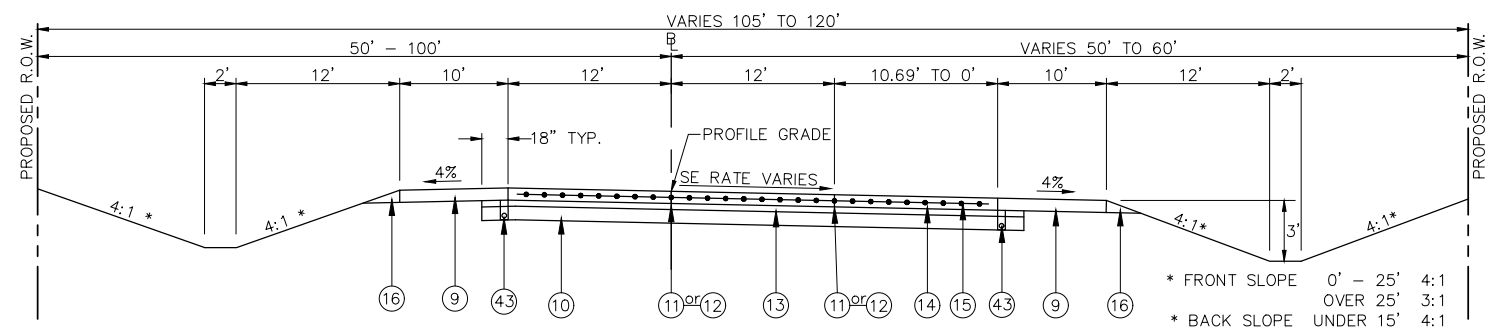

* FRONT SLOPE 0' - 25' 4:1
OVER 25' 3:1
* BACK SLOPE UNDER 15' 4:1
OVER 15' 3:1

**PROPOSED TYPICAL SECTION
FRANK SCOTT PARKWAY EAST**
STA. 205+92.36 TO STA. 210+19.91
(NOT TO SCALE)

SUPERELEVATION DATA	
SLOPE	STATION
TRANS. (NORMAL CROWN TO 4.00%)	205+92.36 TO 207+24.36
FULL SUPER (4.00%)	207+24.36 TO 217+15.19
TRANS. (4.00% TO NORMAL CROWN)	217+15.19 TO 218+47.19

LEGEND

- ① EXISTING P.C.C. PAVEMENT AND PAVEMENT FABRIC
 - ② EXISTING HOT-MIX ASPHALT SURFACE COURSE
 - ③ EXISTING LIME MODIFIED SOILS
 - ④ EXISTING BITUMINOUS BASE COURSE
 - ⑤ EXISTING STABILIZED SUB-BASE
 - ⑥ EXISTING HOT-MIX ASPHALT BINDER COURSE
 - ⑦ EXISTING AGGREGATE BASE WITH BITUMINOUS SURFACE TREATMENT
 - ⑧ EXISTING HOT-MIX ASPHALT SHOULDERS
 - ⑨ PROPOSED HOT-MIX ASPHALT SHOULDERS, 8"
 - ⑩ PROPOSED PROCESSING MODIFIED SOIL, 12"
 - ⑪ PROPOSED SAWED LONGITUDINAL JOINT (SEE HIGHWAY STANDARD 420001)
 - ⑫ PROPOSED LONGITUDINAL CONSTRUCTION JOINT (SEE HIGHWAY STANDARD 420001)
 - ⑬ PROPOSED SUB-BASE GRANULAR MATERIAL, TYPE A, 4"
 - ⑭ PROPOSED PORTLAND CEMENT CONCRETE PAVEMENT, 9", TYPE A FINAL FINISH
 - ⑮ PROPOSED PAVEMENT WELDED WIRE REINFORCEMENT (SEE HIGHWAY STANDARD 420701)
 - ⑯ PROPOSED AGGREGATE SHOULDER, TYPE B
 - ⑰ PROPOSED CONCRETE GUTTER, TYPE A (SEE HIGHWAY STANDARD 606101)
 - ⑱ PROPOSED CONCRETE MEDIAN SURFACE, 4" (SEE HIGHWAY STANDARD 606301)
 - ⑲ PROPOSED HOT-MIX ASPHALT SURFACE COURSE, MIX D, N70, 1 1/2"
 - ⑳ PROPOSED HOT-MIX ASPHALT BINDER COURSE, IL-19.0, N70, 2 1/4"
 - ㉑ PROPOSED HOT-MIX ASPHALT BASE COURSE, 10 1/4"
 - ㉒ PROPOSED EARTH SHOULDER
 - ㉓ PROPOSED HOT-MIX ASPHALT PAVEMENT (FULL DEPTH), 7"
(1 1/2" SURFACE COURSE, 5 1/2" BINDER COURSE) (INITIAL BINDER LIFT THICKNESS = 3")
 - ㉔ PROPOSED COMBINATION CONCRETE CURB & GUTTER, TYPE B-6.24
(SEE HIGHWAY STANDARD 606001)
 - ㉕ PROPOSED HOT-MIX ASPHALT PAVEMENT (FULL DEPTH), 8"
(2" SURFACE COURSE, 6" BINDER COURSE) (INITIAL BINDER LIFT THICKNESS = 3.75")
 - ㉖ PROPOSED HOT-MIX ASPHALT PAVEMENT (FULL DEPTH), 10 3/4"
(2" SURFACE COURSE, 8 3/4" BINDER COURSE) (INITIAL BINDER LIFT THICKNESS = 4")
 - ㉗ PROPOSED PORTLAND CEMENT CONCRETE PAVEMENT, 8"
 - ㉘ PROPOSED HOT-MIX ASPHALT SURFACE REMOVAL, 1 1/2" AND HOT-MIX ASPHALT SURFACE COURSE, MIX D, N70, 1 1/2"
 - ㉙ PROPOSED AGGREGATE BASE COURSE, TYPE A, 8"
 - ㉚ PROPOSED COMBINATION CONCRETE CURB AND GUTTER, TYPE M-6.06
(SEE HIGHWAY STANDARD 606001)
 - ㉛ PROPOSED COMBINATION CONCRETE CURB AND GUTTER, TYPE M-6.24
(SEE HIGHWAY STANDARD 606001)
 - ㉜ PROPOSED SUBBASE GRANULAR MATERIAL, TYPE A, 10"
 - ㉝ EXISTING AGGREGATE BASE COURSE
 - ㉞ EXISTING COMBINATION CONCRETE CURB AND GUTTER, TYPE M-6.06
 - ㉟ EXISTING CONCRETE MEDIAN SURFACE
 - ㊱ EXISTING AGGREGATE SHOULDERS
 - ㊲ PROPOSED DRILL AND GROUT #6 TIE BARS
 - ㊳ EXISTING COMBINATION CONCRETE CURB AND GUTTER, TYPE M-6.12
 - ㊴ EXISTING CONTINUOUSLY REINFORCED PORTLAND CEMENT CONCRETE PAVEMENT
 - ㊵ PROPOSED HOT-MIX ASPHALT SURFACE COURSE, IL 9.5, MIX D, N70, 1 1/2"
 - ㊶ EXISTING HOT-MIX ASPHALT SURFACE
 - ㊷ EXISTING COMBINATION CONCRETE CURB AND GUTTER, TYPE B-6.24
 - ㊸ PROPOSED PIPE UNDERDRAINS, 4" (SPECIAL)
 - ㊹ PROPOSED LONGITUDINAL JOINT SEALANT
 - ㊺ PROPOSED AGGREGATE BASE COURSE, TYPE A, 12"
 - ㊻ PROPOSED HOT-MIX ASPHALT BINDER COURSE, IL 9.5FG, N70, 1 1/4"
- SEE PLAN SHEETS FOR VARIABLE HORIZONTAL DIMENSIONS.

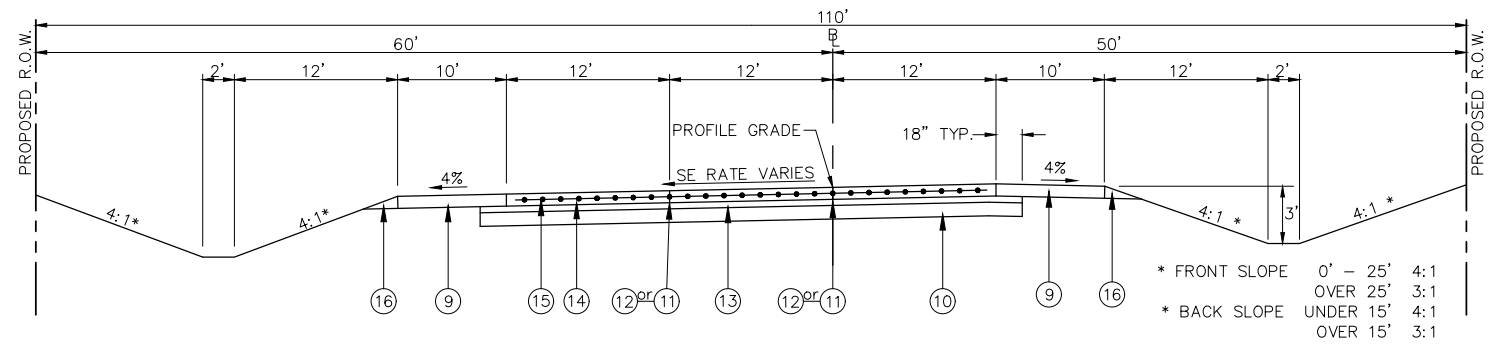

**PROPOSED TYPICAL SECTION
FRANK SCOTT PARKWAY EAST**

STA. 236+03.00 TO STA. 242+12.62
(NOT TO SCALE)

SUPERELEVATION DATA	
SLOPE	STATION
TRANS. (NORMAL CROWN TO 4.00%)	232+61.79 TO 233+93.79
FULL SUPER (4.00%)	233+93.79 TO 247+95.12
TRANS. (4.00% TO NORMAL CROWN)	247+95.12 TO 249+27.12

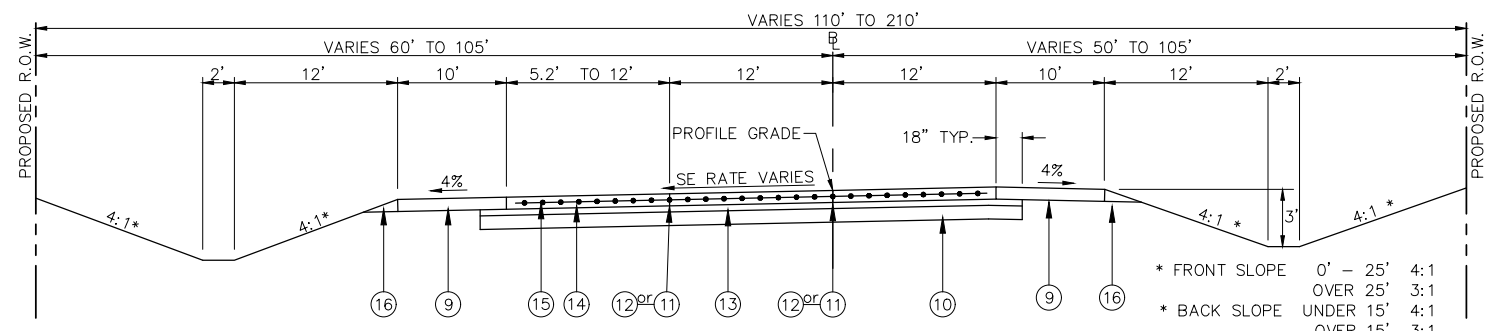

**PROPOSED TYPICAL SECTION
FRANK SCOTT PARKWAY EAST**

STA. 232+61.79 TO STA. 236+03.00
(NOT TO SCALE)

SUPERELEVATION DATA	
SLOPE	STATION
TRANS. (NORMAL CROWN TO 4.00%)	232+61.79 TO 233+93.79
FULL SUPER (4.00%)	233+93.79 TO 247+95.12
TRANS. (4.00% TO NORMAL CROWN)	247+95.12 TO 249+27.12

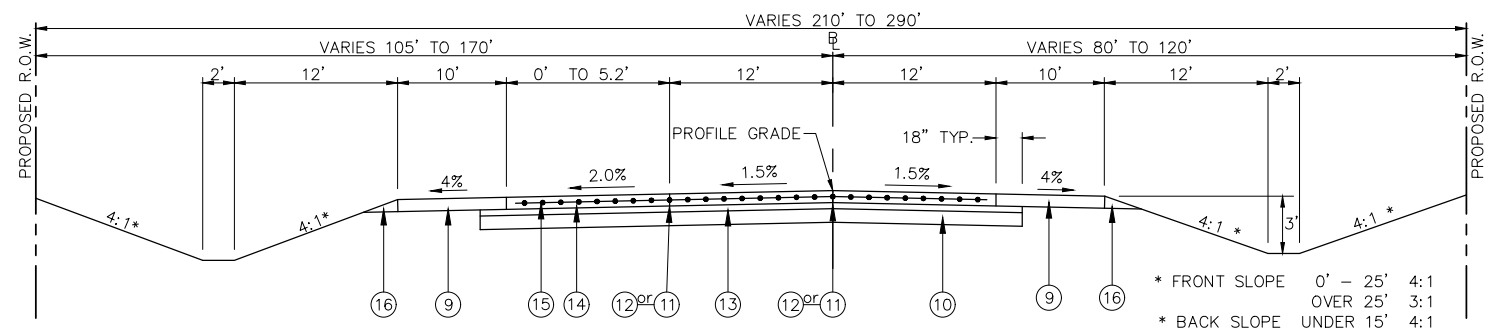

**PROPOSED TYPICAL SECTION
FRANK SCOTT PARKWAY EAST**

STA. 230+03.00 TO STA. 232+61.79
(NOT TO SCALE)

LEGEND

- ① EXISTING P.C.C. PAVEMENT AND PAVEMENT FABRIC
 - ② EXISTING HOT-MIX ASPHALT SURFACE COURSE
 - ③ EXISTING LIME MODIFIED SOILS
 - ④ EXISTING BITUMINOUS BASE COURSE
 - ⑤ EXISTING STABILIZED SUB-BASE
 - ⑥ EXISTING HOT-MIX ASPHALT BINDER COURSE
 - ⑦ EXISTING AGGREGATE BASE WITH BITUMINOUS SURFACE TREATMENT
 - ⑧ EXISTING HOT-MIX ASPHALT SHOULDERS
 - ⑨ PROPOSED HOT-MIX ASPHALT SHOULDERS, 8"
 - ⑩ PROPOSED PROCESSING MODIFIED SOIL, 12"
 - ⑪ PROPOSED SAWED LONGITUDINAL JOINT (SEE HIGHWAY STANDARD 420001)
 - ⑫ PROPOSED LONGITUDINAL CONSTRUCTION JOINT (SEE HIGHWAY STANDARD 420001)
 - ⑬ PROPOSED SUB-BASE GRANULAR MATERIAL, TYPE A, 4"
 - ⑭ PROPOSED PORTLAND CEMENT CONCRETE PAVEMENT, 9", TYPE A FINAL FINISH
 - ⑮ PROPOSED PAVEMENT WELDED WIRE REINFORCEMENT (SEE HIGHWAY STANDARD 420701)
 - ⑯ PROPOSED AGGREGATE SHOULDER, TYPE B
 - ⑰ PROPOSED CONCRETE GUTTER, TYPE A (SEE HIGHWAY STANDARD 606101)
 - ⑱ PROPOSED CONCRETE MEDIAN SURFACE, 4" (SEE HIGHWAY STANDARD 606301)
 - ⑲ PROPOSED HOT-MIX ASPHALT SURFACE COURSE, MIX D, N70, 1 1/2"
 - ⑲ PROPOSED HOT-MIX ASPHALT BINDER COURSE, IL-19.0, N70, 2 1/4"
 - ⑲ PROPOSED HOT-MIX ASPHALT BASE COURSE, 10 1/4"
 - ⑲ PROPOSED EARTH SHOULDER
 - ⑲ PROPOSED HOT-MIX ASPHALT PAVEMENT (FULL DEPTH), 7"
(1 1/2" SURFACE COURSE, 5 1/2" BINDER COURSE) (INITIAL BINDER LIFT THICKNESS = 3")
 - ⑲ PROPOSED COMBINATION CONCRETE CURB & GUTTER, TYPE B-6.24
(SEE HIGHWAY STANDARD 606001)
 - ⑲ PROPOSED HOT-MIX ASPHALT PAVEMENT (FULL DEPTH), 8"
(2" SURFACE COURSE, 6" BINDER COURSE) (INITIAL BINDER LIFT THICKNESS = 3.75")
 - ⑲ PROPOSED HOT-MIX ASPHALT PAVEMENT (FULL DEPTH), 10 3/4"
(2" SURFACE COURSE, 8 3/4" BINDER COURSE) (INITIAL BINDER LIFT THICKNESS = 4")
 - ⑲ PROPOSED PORTLAND CEMENT CONCRETE PAVEMENT, 8"
 - ⑲ PROPOSED HOT-MIX ASPHALT SURFACE REMOVAL, 1 1/2" AND HOT-MIX ASPHALT SURFACE COURSE, MIX D, N70, 1 1/2"
 - ⑲ PROPOSED AGGREGATE BASE COURSE, TYPE A, 8"
 - ⑲ PROPOSED COMBINATION CONCRETE CURB AND GUTTER, TYPE M-6.06
(SEE HIGHWAY STANDARD 606001)
 - ⑲ PROPOSED COMBINATION CONCRETE CURB AND GUTTER, TYPE M-6.24
(SEE HIGHWAY STANDARD 606001)
 - ⑲ PROPOSED SUBBASE GRANULAR MATERIAL, TYPE A, 10"
 - ⑳ EXISTING AGGREGATE BASE COURSE
 - ㉑ EXISTING COMBINATION CONCRETE CURB AND GUTTER, TYPE M-6.06
 - ㉒ EXISTING CONCRETE MEDIAN SURFACE
 - ㉓ EXISTING AGGREGATE SHOULDERS
 - ㉔ PROPOSED DRILL AND GROUT #6 TIE BARS
 - ㉕ EXISTING COMBINATION CONCRETE CURB AND GUTTER, TYPE M-6.12
 - ㉖ EXISTING CONTINUOUSLY REINFORCED PORTLAND CEMENT CONCRETE PAVEMENT
 - ㉗ PROPOSED HOT-MIX ASPHALT SURFACE COURSE, IL 9.5, MIX D, N70, 1 1/2"
 - ㉘ EXISTING HOT-MIX ASPHALT SURFACE
 - ㉙ EXISTING COMBINATION CONCRETE CURB AND GUTTER, TYPE B-6.24
 - ㉚ PROPOSED PIPE UNDERDRAINS, 4" (SPECIAL)
 - ㉛ PROPOSED LONGITUDINAL JOINT SEALANT
 - ㉜ PROPOSED AGGREGATE BASE COURSE, TYPE A, 12"
 - ㉝ PROPOSED HOT-MIX ASPHALT BINDER COURSE, IL 9.5FG, N70, 1 1/4"
- SEE PLAN SHEETS FOR VARIABLE HORIZONTAL DIMENSIONS.

F.A.U. RTE.	SECTION	COUNTY	TOTAL SHEETS	SHEET NO.
9330	95-00301-03-PV	ST. CLAIR	166	18
STA.	TO STA.			
FED. ROAD DIST. NO.	ILLINOIS	FED. AID PROJECT		
FRANK SCOTT PARKWAY EAST TYPICAL SECTIONS				
CONTRACT NO.: 97372				

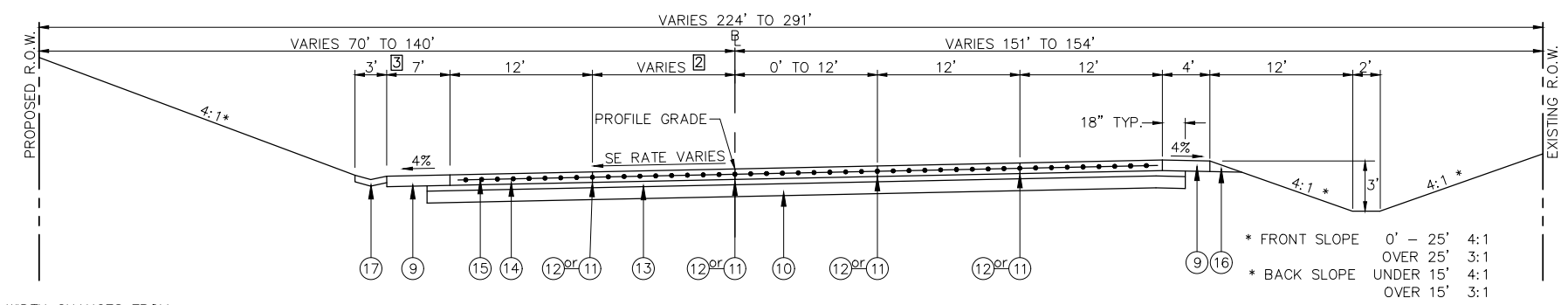

NOTES:

- ② PAVEMENT WIDTH CHANGES FROM:
16.2' TO 20.4' FROM STA 245+00.00 TO STA 246+00.00
20.4' TO 16.6' FROM STA 246+00.00 TO STA 247+34.76
16.6' TO 18.0' FROM STA 247+34.76 TO STA 248+23.12
SEE PLANS
- ③ STA 248+00.00 GUTTER TYPE A STOPS
SHOULDER INCREASES FROM 7' TO 10'

**PROPOSED TYPICAL SECTION
FRANK SCOTT PARKWAY EAST**

STA. 245+00.00 TO STA. 248+23.12
(NOT TO SCALE)

SUPERELEVATION DATA	
SLOPE	STATION
TRANS. (NORMAL CROWN TO 4.00%)	232+61.79 TO 233+93.79
FULL SUPER (4.00%)	233+93.79 TO 247+95.12
TRANS. (4.00% TO NORMAL CROWN)	247+95.12 TO 249+27.12

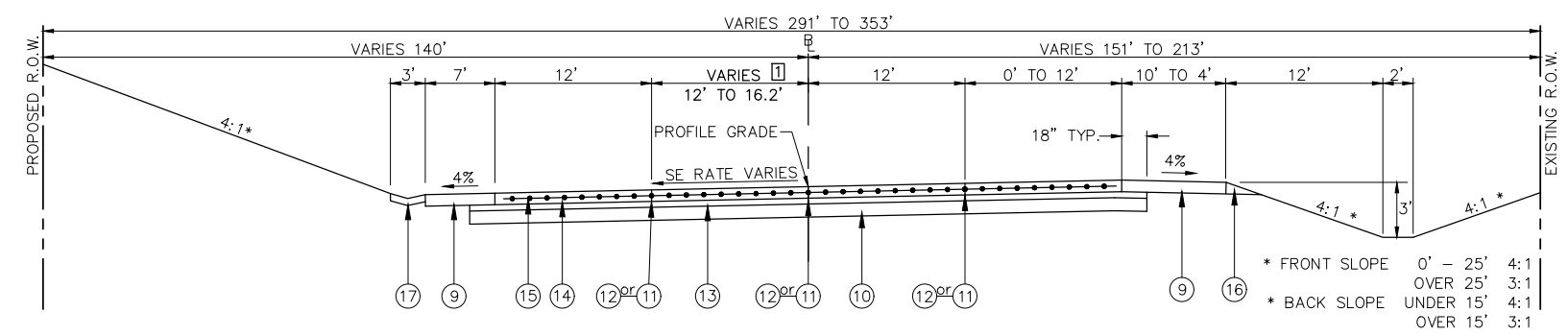

NOTES:

- ① PAVEMENT WIDTH INCREASE STARTING AT STA 244+00.00

**PROPOSED TYPICAL SECTION
FRANK SCOTT PARKWAY EAST**

STA. 242+80.00 TO STA. 245+00.00
(NOT TO SCALE)

SUPERELEVATION DATA	
SLOPE	STATION
TRANS. (NORMAL CROWN TO 4.00%)	232+61.79 TO 233+93.79
FULL SUPER (4.00%)	233+93.79 TO 247+95.12
TRANS. (4.00% TO NORMAL CROWN)	247+95.12 TO 249+27.12

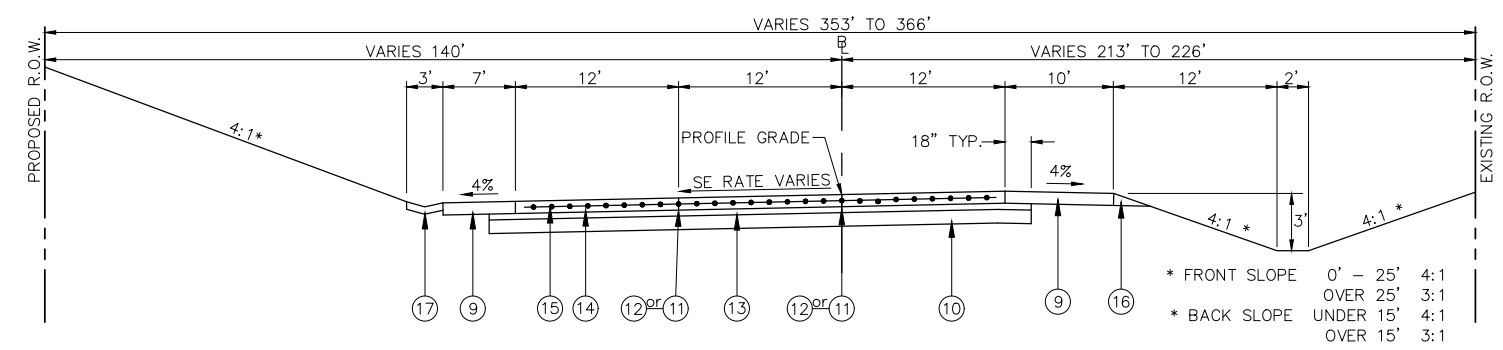

**PROPOSED TYPICAL SECTION
FRANK SCOTT PARKWAY EAST**

STA. 242+12.62 TO STA. 242+80.00
(NOT TO SCALE)

SUPERELEVATION DATA	
SLOPE	STATION
TRANS. (NORMAL CROWN TO 4.00%)	232+61.79 TO 233+93.79
FULL SUPER (4.00%)	233+93.79 TO 247+95.12
TRANS. (4.00% TO NORMAL CROWN)	247+95.12 TO 249+27.12

LEGEND

- ① EXISTING P.C.C. PAVEMENT AND PAVEMENT FABRIC
- ② EXISTING HOT-MIX ASPHALT SURFACE COURSE
- ③ EXISTING LIME MODIFIED SOILS
- ④ EXISTING BITUMINOUS BASE COURSE
- ⑤ EXISTING STABILIZED SUB-BASE
- ⑥ EXISTING HOT-MIX ASPHALT BINDER COURSE
- ⑦ EXISTING AGGREGATE BASE WITH BITUMINOUS SURFACE TREATMENT
- ⑧ EXISTING HOT-MIX ASPHALT SHOULDERS
- ⑨ PROPOSED HOT-MIX ASPHALT SHOULDERS, 8"
- ⑩ PROPOSED PROCESSING MODIFIED SOIL, 12"
- ⑪ PROPOSED SAWED LONGITUDINAL JOINT (SEE HIGHWAY STANDARD 420001)
- ⑫ PROPOSED LONGITUDINAL CONSTRUCTION JOINT (SEE HIGHWAY STANDARD 420001)
- ⑬ PROPOSED SUB-BASE GRANULAR MATERIAL, TYPE A, 4"
- ⑭ PROPOSED PORTLAND CEMENT CONCRETE PAVEMENT, 9", TYPE A FINAL FINISH
- ⑮ PROPOSED PAVEMENT WELDED WIRE REINFORCEMENT (SEE HIGHWAY STANDARD 420701)
- ⑯ PROPOSED AGGREGATE SHOULDER, TYPE B
- ⑰ PROPOSED CONCRETE GUTTER, TYPE A (SEE HIGHWAY STANDARD 606101)
- ⑱ PROPOSED CONCRETE MEDIAN SURFACE, 4" (SEE HIGHWAY STANDARD 606301)
- ⑲ PROPOSED HOT-MIX ASPHALT SURFACE COURSE, MIX D, N70, 1 1/2"
- ⑳ PROPOSED HOT-MIX ASPHALT BINDER COURSE, IL-19.0, N70, 2 1/4"
- ㉑ PROPOSED HOT-MIX ASPHALT BASE COURSE, 10 1/4"
- ㉒ PROPOSED EARTH SHOULDER
- ㉓ PROPOSED HOT-MIX ASPHALT PAVEMENT (FULL DEPTH), 7"
(1 1/2" SURFACE COURSE, 5 1/2" BINDER COURSE) (INITIAL BINDER LIFT THICKNESS = 3")
- ㉔ PROPOSED COMBINATION CONCRETE CURB & GUTTER, TYPE B-6.24
(SEE HIGHWAY STANDARD 606001)
- ㉕ PROPOSED HOT-MIX ASPHALT PAVEMENT (FULL DEPTH), 8"
(2" SURFACE COURSE, 6" BINDER COURSE) (INITIAL BINDER LIFT THICKNESS = 3.75")
- ㉖ PROPOSED HOT-MIX ASPHALT PAVEMENT (FULL DEPTH), 10 3/4"
(2" SURFACE COURSE, 8 3/4" BINDER COURSE) (INITIAL BINDER LIFT THICKNESS = 4")
- ㉗ PROPOSED PORTLAND CEMENT CONCRETE PAVEMENT, 8"
- ㉘ PROPOSED HOT-MIX ASPHALT SURFACE REMOVAL, 1 1/2" AND HOT-MIX ASPHALT SURFACE COURSE, MIX D, N70, 1 1/2"
- ㉙ PROPOSED AGGREGATE BASE COURSE, TYPE A, 8"
- ㉚ PROPOSED COMBINATION CONCRETE CURB AND GUTTER, TYPE M-6.06
(SEE HIGHWAY STANDARD 606001)
- ㉛ PROPOSED COMBINATION CONCRETE CURB AND GUTTER, TYPE M-6.24
(SEE HIGHWAY STANDARD 606001)
- ㉜ PROPOSED SUBBASE GRANULAR MATERIAL, TYPE A, 10"
- ㉝ EXISTING AGGREGATE BASE COURSE
- ㉞ EXISTING COMBINATION CONCRETE CURB AND GUTTER, TYPE M-6.06
- ㉟ EXISTING CONCRETE MEDIAN SURFACE
- ㊱ EXISTING AGGREGATE SHOULDERS
- ㊲ PROPOSED DRILL AND GROUT #6 TIE BARS
- ㊳ EXISTING COMBINATION CONCRETE CURB AND GUTTER, TYPE M-6.12
- ㊴ EXISTING CONTINUOUSLY REINFORCED PORTLAND CEMENT CONCRETE PAVEMENT
- ㊵ PROPOSED HOT-MIX ASPHALT SURFACE COURSE, IL 9.5, MIX D, N70, 1 1/2"
- ㊶ EXISTING HOT-MIX ASPHALT SURFACE
- ㊷ EXISTING COMBINATION CONCRETE CURB AND GUTTER, TYPE B-6.24
- ㊸ PROPOSED PIPE UNDERDRAINS, 4" (SPECIAL)
- ㊹ PROPOSED LONGITUDINAL JOINT SEALANT
- ㊺ PROPOSED AGGREGATE BASE COURSE, TYPE A, 12"
- ㊻ PROPOSED HOT-MIX ASPHALT BINDER COURSE, IL 9.5FG, N70, 1 1/4"
SEE PLAN SHEETS FOR VARIABLE HORIZONTAL DIMENSIONS.

F.A.U. RTE.	SECTION	COUNTY	TOTAL SHEETS	SHEET NO.
9330	95-00301-03-PV	ST. CLAIR	166	19
STA.	TO STA.			
FED. ROAD DIST. NO.	ILLINOIS	FED. AID PROJECT		
FRANK SCOTT PARKWAY EAST TYPICAL SECTIONS				
CONTRACT NO.: 97372				

LEGEND

- ① EXISTING P.C.C. PAVEMENT AND PAVEMENT FABRIC
 - ② EXISTING HOT-MIX ASPHALT SURFACE COURSE
 - ③ EXISTING LIME MODIFIED SOILS
 - ④ EXISTING BITUMINOUS BASE COURSE
 - ⑤ EXISTING STABILIZED SUB-BASE
 - ⑥ EXISTING HOT-MIX ASPHALT BINDER COURSE
 - ⑦ EXISTING AGGREGATE BASE WITH BITUMINOUS SURFACE TREATMENT
 - ⑧ EXISTING HOT-MIX ASPHALT SHOULDERS
 - ⑨ PROPOSED HOT-MIX ASPHALT SHOULDERS, 8"
 - ⑩ PROPOSED PROCESSING MODIFIED SOIL, 12"
 - ⑪ PROPOSED SAWED LONGITUDINAL JOINT (SEE HIGHWAY STANDARD 420001)
 - ⑫ PROPOSED LONGITUDINAL CONSTRUCTION JOINT (SEE HIGHWAY STANDARD 420001)
 - ⑬ PROPOSED SUB-BASE GRANULAR MATERIAL, TYPE A, 4"
 - ⑭ PROPOSED PORTLAND CEMENT CONCRETE PAVEMENT, 9", TYPE A FINAL FINISH
 - ⑮ PROPOSED PAVEMENT WELDED WIRE REINFORCEMENT (SEE HIGHWAY STANDARD 420701)
 - ⑯ PROPOSED AGGREGATE SHOULDER, TYPE B
 - ⑰ PROPOSED CONCRETE GUTTER, TYPE A (SEE HIGHWAY STANDARD 606101)
 - ⑱ PROPOSED CONCRETE MEDIAN SURFACE, 4" (SEE HIGHWAY STANDARD 606301)
 - ⑲ PROPOSED HOT-MIX ASPHALT SURFACE COURSE, MIX D, N70, 1 1/2"
 - ⑲ PROPOSED HOT-MIX ASPHALT BINDER COURSE, IL-19.0, N70, 2 1/4"
 - ⑲ PROPOSED HOT-MIX ASPHALT BASE COURSE, 10 1/4"
 - ⑲ PROPOSED EARTH SHOULDER
 - ⑲ PROPOSED HOT-MIX ASPHALT PAVEMENT (FULL DEPTH), 7" (1 1/2" SURFACE COURSE, 5 1/2" BINDER COURSE) (INITIAL BINDER LIFT THICKNESS = 3")
 - ⑲ PROPOSED COMBINATION CONCRETE CURB & GUTTER, TYPE B-6.24 (SEE HIGHWAY STANDARD 606001)
 - ⑲ PROPOSED HOT-MIX ASPHALT PAVEMENT (FULL DEPTH), 8" (2" SURFACE COURSE, 6" BINDER COURSE) (INITIAL BINDER LIFT THICKNESS = 3.75")
 - ⑲ PROPOSED HOT-MIX ASPHALT PAVEMENT (FULL DEPTH), 10 3/4" (2" SURFACE COURSE, 8 3/4" BINDER COURSE) (INITIAL BINDER LIFT THICKNESS = 4")
 - ⑲ PROPOSED PORTLAND CEMENT CONCRETE PAVEMENT, 8"
 - ⑲ PROPOSED HOT-MIX ASPHALT SURFACE REMOVAL, 1 1/2" AND HOT-MIX ASPHALT SURFACE COURSE, MIX D, N70, 1 1/2"
 - ⑲ PROPOSED AGGREGATE BASE COURSE, TYPE A, 8"
 - ⑳ PROPOSED COMBINATION CONCRETE CURB AND GUTTER, TYPE M-6.06 (SEE HIGHWAY STANDARD 606001)
 - ⑳ PROPOSED COMBINATION CONCRETE CURB AND GUTTER, TYPE M-6.24 (SEE HIGHWAY STANDARD 606001)
 - ㉑ PROPOSED SUBBASE GRANULAR MATERIAL, TYPE A, 10"
 - ㉒ EXISTING AGGREGATE BASE COURSE
 - ㉒ EXISTING COMBINATION CONCRETE CURB AND GUTTER, TYPE M-6.06
 - ㉒ EXISTING CONCRETE MEDIAN SURFACE
 - ㉒ EXISTING AGGREGATE SHOULDERS
 - ㉒ PROPOSED DRILL AND GROUT #6 TIE BARS
 - ㉒ EXISTING COMBINATION CONCRETE CURB AND GUTTER, TYPE M-6.12
 - ㉒ EXISTING CONTINUOUSLY REINFORCED PORTLAND CEMENT CONCRETE PAVEMENT
 - ㉒ PROPOSED HOT-MIX ASPHALT SURFACE COURSE, IL 9.5, MIX D, N70, 1 1/2"
 - ㉒ EXISTING HOT-MIX ASPHALT SURFACE
 - ㉒ EXISTING COMBINATION CONCRETE CURB AND GUTTER, TYPE B-6.24
 - ㉒ PROPOSED PIPE UNDERDRAINS, 4" (SPECIAL)
 - ㉒ PROPOSED LONGITUDINAL JOINT SEALANT
 - ㉒ PROPOSED AGGREGATE BASE COURSE, TYPE A, 12"
 - ㉒ PROPOSED HOT-MIX ASPHALT BINDER COURSE, IL 9.5FG, N70, 1 1/4"
- SEE PLAN SHEETS FOR VARIABLE HORIZONTAL DIMENSIONS.

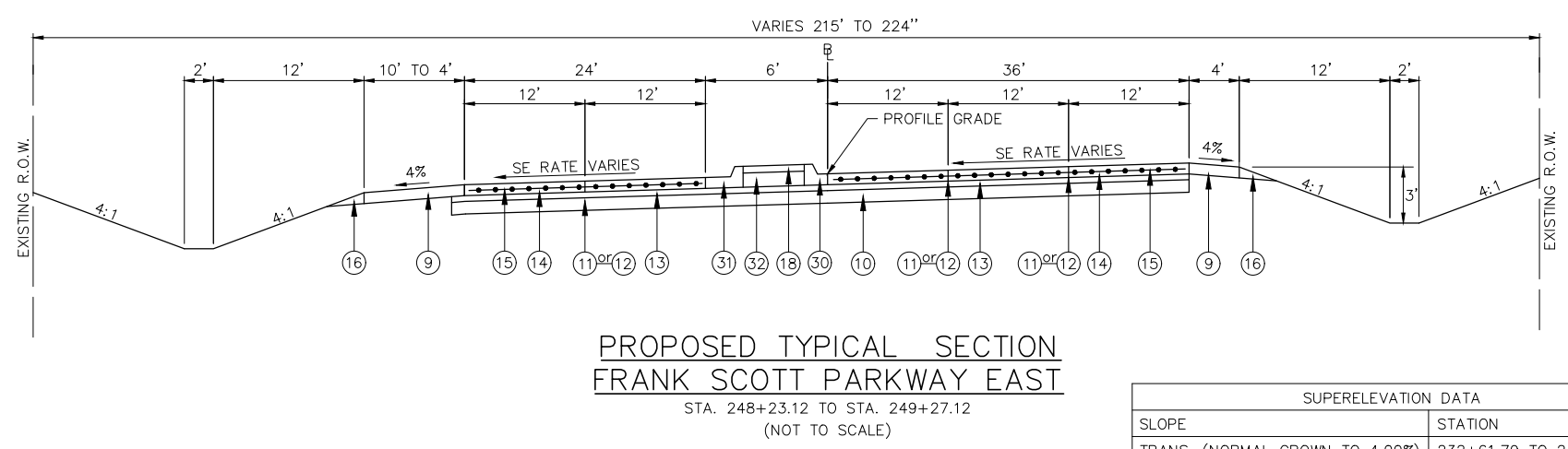
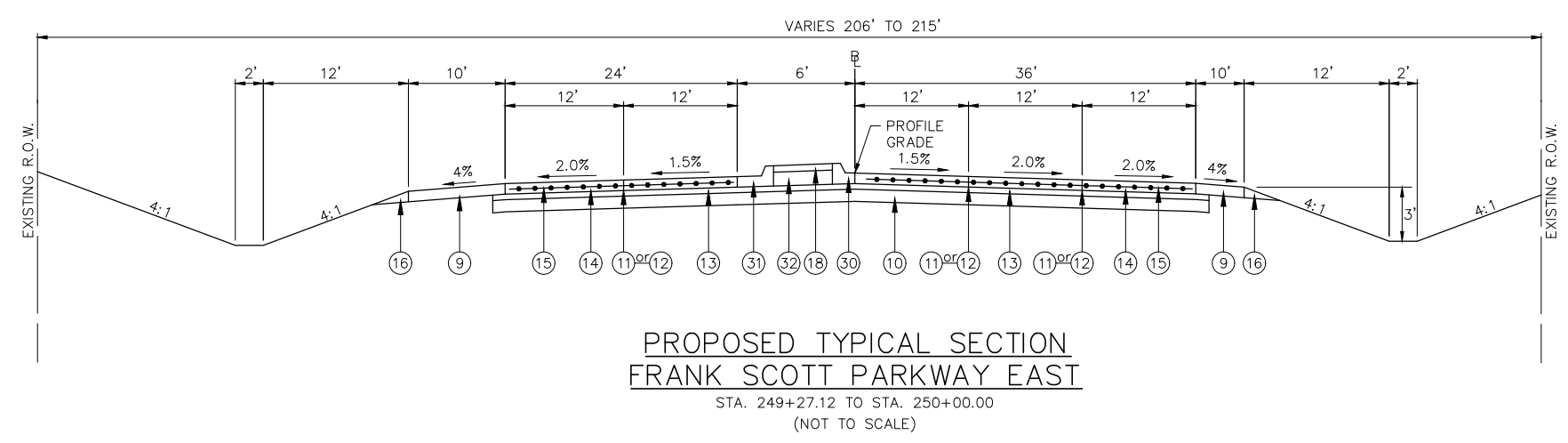
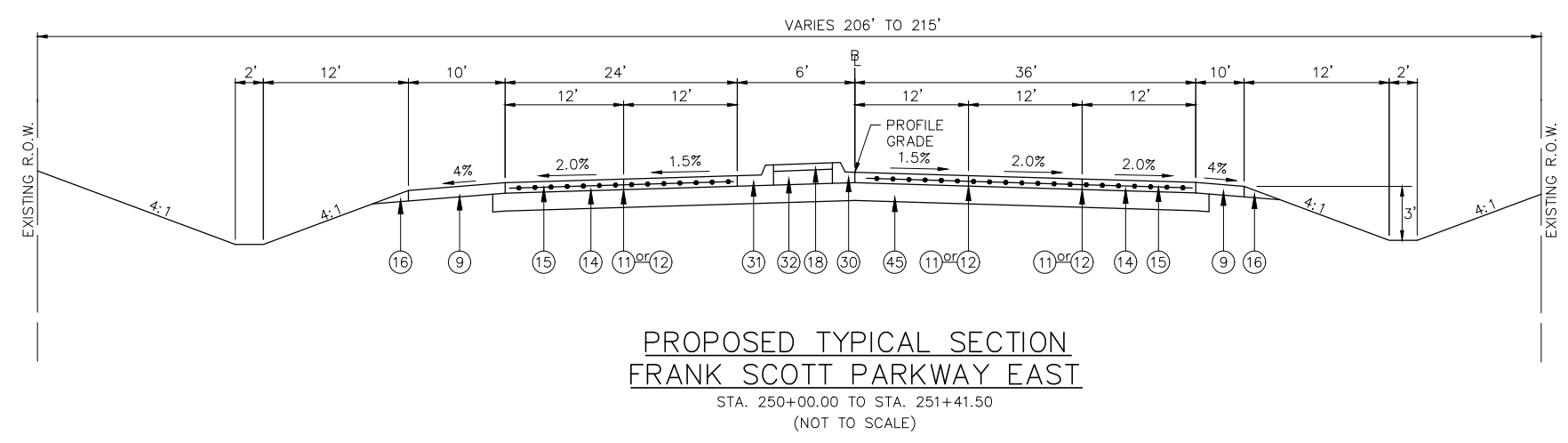

SUPERELEVATION DATA	
SLOPE	STATION
TRANS. (NORMAL CROWN TO 4.00%)	232+61.79 TO 233+93.79
FULL SUPER (4.00%)	233+93.79 TO 247+95.12
TRANS. (4.00% TO NORMAL CROWN)	247+95.12 TO 249+27.12

F.A.U. RTE.	SECTION	COUNTY	TOTAL SHEETS	SHEET NO.
9330	95-00301-03-PV	ST. CLAIR	166	20
STA.		TO STA.		
FED. ROAD DIST. NO.	ILLINOIS	FED. AID PROJECT		
FRANK SCOTT PARKWAY EAST TYPICAL SECTIONS				

CONTRACT NO.: 97372

LEGEND

- ① EXISTING P.C.C. PAVEMENT AND PAVEMENT FABRIC
 - ② EXISTING HOT-MIX ASPHALT SURFACE COURSE
 - ③ EXISTING LIME MODIFIED SOILS
 - ④ EXISTING BITUMINOUS BASE COURSE
 - ⑤ EXISTING STABILIZED SUB-BASE
 - ⑥ EXISTING HOT-MIX ASPHALT BINDER COURSE
 - ⑦ EXISTING AGGREGATE BASE WITH BITUMINOUS SURFACE TREATMENT
 - ⑧ EXISTING HOT-MIX ASPHALT SHOULDERS
 - ⑨ PROPOSED HOT-MIX ASPHALT SHOULDERS, 8"
 - ⑩ PROPOSED PROCESSING MODIFIED SOIL, 12"
 - ⑪ PROPOSED SAWED LONGITUDINAL JOINT (SEE HIGHWAY STANDARD 420001)
 - ⑫ PROPOSED LONGITUDINAL CONSTRUCTION JOINT (SEE HIGHWAY STANDARD 420001)
 - ⑬ PROPOSED SUB-BASE GRANULAR MATERIAL, TYPE A, 4"
 - ⑭ PROPOSED PORTLAND CEMENT CONCRETE PAVEMENT, 9", TYPE A FINAL FINISH
 - ⑮ PROPOSED PAVEMENT WELDED WIRE REINFORCEMENT (SEE HIGHWAY STANDARD 420701)
 - ⑯ PROPOSED AGGREGATE SHOULDER, TYPE B
 - ⑰ PROPOSED CONCRETE GUTTER, TYPE A (SEE HIGHWAY STANDARD 606101)
 - ⑱ PROPOSED CONCRETE MEDIAN SURFACE, 4" (SEE HIGHWAY STANDARD 606301)
 - ⑲ PROPOSED HOT-MIX ASPHALT SURFACE COURSE, MIX D, N70, 1 1/2"
 - ⑳ PROPOSED HOT-MIX ASPHALT BINDER COURSE, IL-19.0, N70, 2 1/4"
 - ㉑ PROPOSED HOT-MIX ASPHALT BASE COURSE, 10 1/4"
 - ㉒ PROPOSED EARTH SHOULDER
 - ㉓ PROPOSED HOT-MIX ASPHALT PAVEMENT (FULL DEPTH), 7" (1 1/2" SURFACE COURSE, 5 1/2" BINDER COURSE) (INITIAL BINDER LIFT THICKNESS = 3")
 - ㉔ PROPOSED COMBINATION CONCRETE CURB & GUTTER, TYPE B-6.24 (SEE HIGHWAY STANDARD 606001)
 - ㉕ PROPOSED HOT-MIX ASPHALT PAVEMENT (FULL DEPTH), 8" (2" SURFACE COURSE, 6" BINDER COURSE) (INITIAL BINDER LIFT THICKNESS = 3.75")
 - ㉖ PROPOSED HOT-MIX ASPHALT PAVEMENT (FULL DEPTH), 10 3/4" (2" SURFACE COURSE, 8 3/4" BINDER COURSE) (INITIAL BINDER LIFT THICKNESS = 4")
 - ㉗ PROPOSED PORTLAND CEMENT CONCRETE PAVEMENT, 8"
 - ㉘ PROPOSED HOT-MIX ASPHALT SURFACE REMOVAL, 1 1/2" AND HOT-MIX ASPHALT SURFACE COURSE, MIX D, N70, 1 1/2"
 - ㉙ PROPOSED AGGREGATE BASE COURSE, TYPE A, 8"
 - ㉚ PROPOSED COMBINATION CONCRETE CURB AND GUTTER, TYPE M-6.06 (SEE HIGHWAY STANDARD 606001)
 - ㉛ PROPOSED COMBINATION CONCRETE CURB AND GUTTER, TYPE M-6.24 (SEE HIGHWAY STANDARD 606001)
 - ㉜ PROPOSED SUBBASE GRANULAR MATERIAL, TYPE A, 10"
 - ㉝ EXISTING AGGREGATE BASE COURSE
 - ㉞ EXISTING COMBINATION CONCRETE CURB AND GUTTER, TYPE M-6.06
 - ㉟ EXISTING CONCRETE MEDIAN SURFACE
 - ㊱ EXISTING AGGREGATE SHOULDERS
 - ㊲ PROPOSED DRILL AND GROUT #6 TIE BARS
 - ㊳ EXISTING COMBINATION CONCRETE CURB AND GUTTER, TYPE M-6.12
 - ㊴ EXISTING CONTINUOUSLY REINFORCED PORTLAND CEMENT CONCRETE PAVEMENT
 - ㊵ PROPOSED HOT-MIX ASPHALT SURFACE COURSE, IL 9.5, MIX D, N70, 1 1/2"
 - ㊶ EXISTING HOT-MIX ASPHALT SURFACE
 - ㊷ EXISTING COMBINATION CONCRETE CURB AND GUTTER, TYPE B-6.24
 - ㊸ PROPOSED PIPE UNDERDRAINS, 4" (SPECIAL)
 - ㊹ PROPOSED LONGITUDINAL JOINT SEALANT
 - ㊺ PROPOSED AGGREGATE BASE COURSE, TYPE A, 12"
 - ㊻ PROPOSED HOT-MIX ASPHALT BINDER COURSE, IL 9.5FG, N70, 1 1/4"
- SEE PLAN SHEETS FOR VARIABLE HORIZONTAL DIMENSIONS.

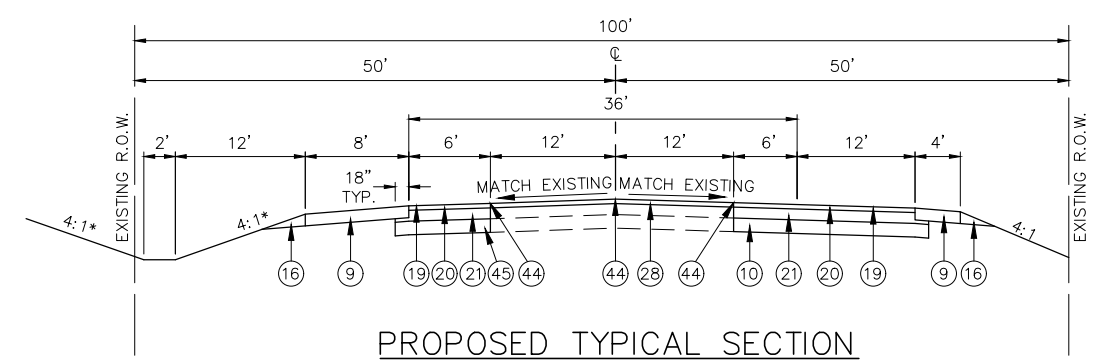

PROPOSED TYPICAL SECTION CROSS STREET

STA. 191+85.00 TO STA. 193+02.00
(NOT TO SCALE) NOTE: RESURFACING TO MATCH EXISTING SLOPES

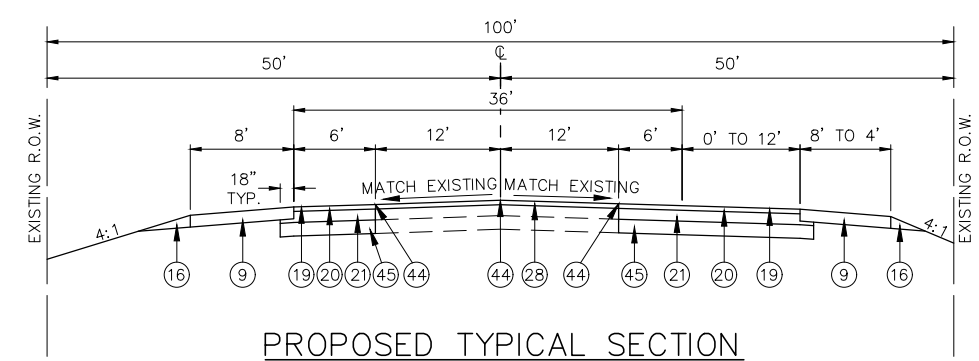

PROPOSED TYPICAL SECTION CROSS STREET

STA. 190+05.00 TO STA. 191+85.00
(NOT TO SCALE) NOTE: RESURFACING TO MATCH EXISTING SLOPES

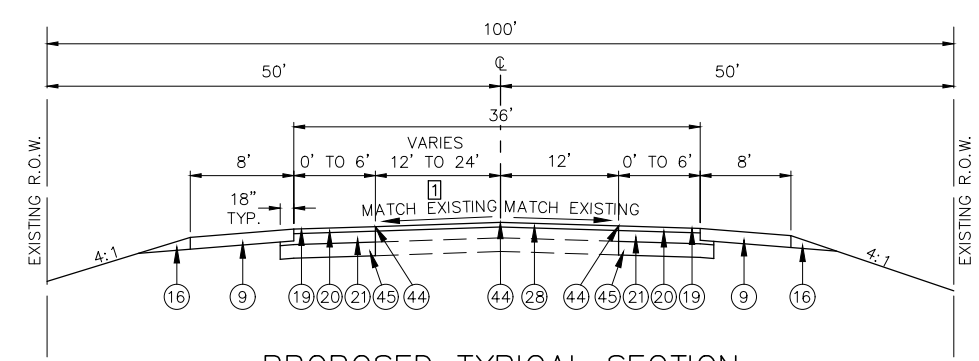

PROPOSED TYPICAL SECTION CROSS STREET

STA. 185+00.00 TO STA. 190+05.00
(NOT TO SCALE) NOTE: RESURFACING TO MATCH EXISTING SLOPES

NOTES:
① LONGITUDINAL JOINT SEALANT 12' SOUTH OF EXISTING NORTH EDGE OF PAVEMENT

F.A.U. RTE.	SECTION	COUNTY	TOTAL SHEETS	SHEET NO.
9330	95-00301-03-PV	ST. CLAIR	166	21
STA.	TO STA.			
FED. ROAD DIST. NO.	ILLINOIS	FED. AID PROJECT		
FRANK SCOTT PARKWAY EAST TYPICAL SECTIONS				

CONTRACT NO.: 97372

LEGEND

- ① EXISTING P.C.C. PAVEMENT AND PAVEMENT FABRIC
- ② EXISTING HOT-MIX ASPHALT SURFACE COURSE
- ③ EXISTING LIME MODIFIED SOILS
- ④ EXISTING BITUMINOUS BASE COURSE
- ⑤ EXISTING STABILIZED SUB-BASE
- ⑥ EXISTING HOT-MIX ASPHALT BINDER COURSE
- ⑦ EXISTING AGGREGATE BASE WITH BITUMINOUS SURFACE TREATMENT
- ⑧ EXISTING HOT-MIX ASPHALT SHOULDERS
- ⑨ PROPOSED HOT-MIX ASPHALT SHOULDERS, 8"
- ⑩ PROPOSED PROCESSING MODIFIED SOIL, 12"
- ⑪ PROPOSED SAWED LONGITUDINAL JOINT (SEE HIGHWAY STANDARD 420001)
- ⑫ PROPOSED LONGITUDINAL CONSTRUCTION JOINT (SEE HIGHWAY STANDARD 420001)
- ⑬ PROPOSED SUB-BASE GRANULAR MATERIAL, TYPE A, 4"
- ⑭ PROPOSED PORTLAND CEMENT CONCRETE PAVEMENT, 9", TYPE A FINAL FINISH
- ⑮ PROPOSED PAVEMENT WELDED WIRE REINFORCEMENT (SEE HIGHWAY STANDARD 420701)
- ⑯ PROPOSED AGGREGATE SHOULDER, TYPE B
- ⑰ PROPOSED CONCRETE GUTTER, TYPE A (SEE HIGHWAY STANDARD 606101)
- ⑱ PROPOSED CONCRETE MEDIAN SURFACE, 4" (SEE HIGHWAY STANDARD 606301)
- ⑲ PROPOSED HOT-MIX ASPHALT SURFACE COURSE, MIX D, N70, 1 1/2"
- ⑳ PROPOSED HOT-MIX ASPHALT BINDER COURSE, IL-19.0, N70, 2 1/4"
- ㉑ PROPOSED HOT-MIX ASPHALT BASE COURSE, 10 1/4"
- ㉒ PROPOSED EARTH SHOULDER
- ㉓ PROPOSED HOT-MIX ASPHALT PAVEMENT (FULL DEPTH), 7"
(1 1/2" SURFACE COURSE, 5 1/2" BINDER COURSE) (INITIAL BINDER LIFT THICKNESS = 3")
- ㉔ PROPOSED COMBINATION CONCRETE CURB & GUTTER, TYPE B-6.24
(SEE HIGHWAY STANDARD 606001)
- ㉕ PROPOSED HOT-MIX ASPHALT PAVEMENT (FULL DEPTH), 8"
(2" SURFACE COURSE, 6" BINDER COURSE) (INITIAL BINDER LIFT THICKNESS = 3.75")
- ㉖ PROPOSED HOT-MIX ASPHALT PAVEMENT (FULL DEPTH), 10 3/4"
(2" SURFACE COURSE, 8 3/4" BINDER COURSE) (INITIAL BINDER LIFT THICKNESS = 4")
- ㉗ PROPOSED PORTLAND CEMENT CONCRETE PAVEMENT, 8"
- ㉘ PROPOSED HOT-MIX ASPHALT SURFACE REMOVAL, 1 1/2" AND HOT-MIX ASPHALT SURFACE COURSE, MIX D, N70, 1 1/2"
- ㉙ PROPOSED AGGREGATE BASE COURSE, TYPE A, 8"
- ㉚ PROPOSED COMBINATION CONCRETE CURB AND GUTTER, TYPE M-6.06
(SEE HIGHWAY STANDARD 606001)
- ㉛ PROPOSED COMBINATION CONCRETE CURB AND GUTTER, TYPE M-6.24
(SEE HIGHWAY STANDARD 606001)
- ㉜ PROPOSED SUBBASE GRANULAR MATERIAL, TYPE A, 10"
- ㉝ EXISTING AGGREGATE BASE COURSE
- ㉞ EXISTING COMBINATION CONCRETE CURB AND GUTTER, TYPE M-6.06
- ㉟ EXISTING CONCRETE MEDIAN SURFACE
- ㊱ EXISTING AGGREGATE SHOULDERS
- ㊲ PROPOSED DRILL AND GROUT #6 TIE BARS
- ㊳ EXISTING COMBINATION CONCRETE CURB AND GUTTER, TYPE M-6.12
- ㊴ EXISTING CONTINUOUSLY REINFORCED PORTLAND CEMENT CONCRETE PAVEMENT
- ㊵ PROPOSED HOT-MIX ASPHALT SURFACE COURSE, IL 9.5, MIX D, N70, 1 1/2"
- ㊶ EXISTING HOT-MIX ASPHALT SURFACE
- ㊷ EXISTING COMBINATION CONCRETE CURB AND GUTTER, TYPE B-6.24
- ㊸ PROPOSED PIPE UNDERDRAINS, 4" (SPECIAL)
- ㊹ PROPOSED LONGITUDINAL JOINT SEALANT
- ㊺ PROPOSED AGGREGATE BASE COURSE, TYPE A, 12"
- ㊻ PROPOSED HOT-MIX ASPHALT BINDER COURSE, IL 9.5FG, N70, 1 1/4"
SEE PLAN SHEETS FOR VARIABLE HORIZONTAL DIMENSIONS.

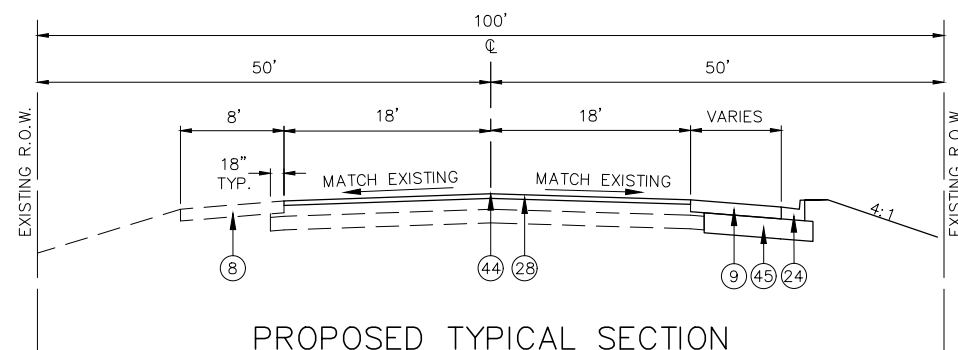

PROPOSED TYPICAL SECTION CROSS STREET

STA. 195+74.85 TO STA. 198+51.35
(NOT TO SCALE) NOTE: RESURFACING TO MATCH EXISTING SLOPES

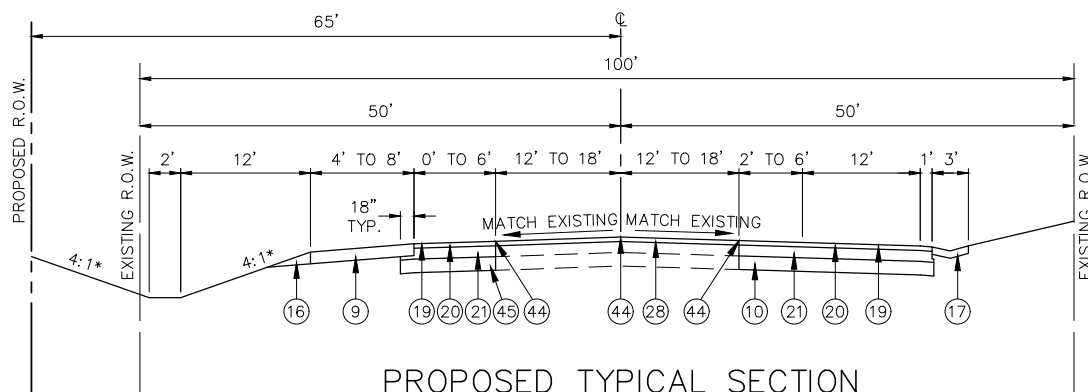

PROPOSED TYPICAL SECTION CROSS STREET

STA. 193+02.00 TO STA. 195+74.85
(NOT TO SCALE) NOTE: RESURFACING TO MATCH EXISTING SLOPES

F.A.U. RTE.	SECTION	COUNTY	TOTAL SHEETS	SHEET NO.
9330	95-00301-03-PV	ST. CLAIR	166	22
STA.		TO STA.		
FED. ROAD DIST. NO.	ILLINOIS	FED. AID PROJECT		
FRANK SCOTT PARKWAY EAST TYPICAL SECTIONS				

CONTRACT NO.: 97372

LEGEND

- ① EXISTING P.C.C. PAVEMENT AND PAVEMENT FABRIC
 - ② EXISTING HOT-MIX ASPHALT SURFACE COURSE
 - ③ EXISTING LIME MODIFIED SOILS
 - ④ EXISTING BITUMINOUS BASE COURSE
 - ⑤ EXISTING STABILIZED SUB-BASE
 - ⑥ EXISTING HOT-MIX ASPHALT BINDER COURSE
 - ⑦ EXISTING AGGREGATE BASE WITH BITUMINOUS SURFACE TREATMENT
 - ⑧ EXISTING HOT-MIX ASPHALT SHOULDERS
 - ⑨ PROPOSED HOT-MIX ASPHALT SHOULDERS, 8"
 - ⑩ PROPOSED PROCESSING MODIFIED SOIL, 12"
 - ⑪ PROPOSED SAWED LONGITUDINAL JOINT (SEE HIGHWAY STANDARD 420001)
 - ⑫ PROPOSED LONGITUDINAL CONSTRUCTION JOINT (SEE HIGHWAY STANDARD 420001)
 - ⑬ PROPOSED SUB-BASE GRANULAR MATERIAL, TYPE A, 4"
 - ⑭ PROPOSED PORTLAND CEMENT CONCRETE PAVEMENT, 9", TYPE A FINAL FINISH
 - ⑮ PROPOSED PAVEMENT WELDED WIRE REINFORCEMENT (SEE HIGHWAY STANDARD 420701)
 - ⑯ PROPOSED AGGREGATE SHOULDER, TYPE B
 - ⑰ PROPOSED CONCRETE GUTTER, TYPE A (SEE HIGHWAY STANDARD 606101)
 - ⑱ PROPOSED CONCRETE MEDIAN SURFACE, 4" (SEE HIGHWAY STANDARD 606301)
 - ⑲ PROPOSED HOT-MIX ASPHALT SURFACE COURSE, MIX D, N70, 1 1/2"
 - ⑳ PROPOSED HOT-MIX ASPHALT BINDER COURSE, IL-19.0, N70, 2 1/4"
 - ㉑ PROPOSED HOT-MIX ASPHALT BASE COURSE, 10 1/4"
 - ㉒ PROPOSED EARTH SHOULDER
 - ㉓ PROPOSED HOT-MIX ASPHALT PAVEMENT (FULL DEPTH), 7" (1 1/2" SURFACE COURSE, 5 1/2" BINDER COURSE) (INITIAL BINDER LIFT THICKNESS = 3")
 - ㉔ PROPOSED COMBINATION CONCRETE CURB & GUTTER, TYPE B-6.24 (SEE HIGHWAY STANDARD 606001)
 - ㉕ PROPOSED HOT-MIX ASPHALT PAVEMENT (FULL DEPTH), 8" (2" SURFACE COURSE, 6" BINDER COURSE) (INITIAL BINDER LIFT THICKNESS = 3.75")
 - ㉖ PROPOSED HOT-MIX ASPHALT PAVEMENT (FULL DEPTH), 10 3/4" (2" SURFACE COURSE, 8 3/4" BINDER COURSE) (INITIAL BINDER LIFT THICKNESS = 4")
 - ㉗ PROPOSED PORTLAND CEMENT CONCRETE PAVEMENT, 8"
 - ㉘ PROPOSED HOT-MIX ASPHALT SURFACE REMOVAL, 1 1/2" AND HOT-MIX ASPHALT SURFACE COURSE, MIX D, N70, 1 1/2"
 - ㉙ PROPOSED AGGREGATE BASE COURSE, TYPE A, 8"
 - ㉚ PROPOSED COMBINATION CONCRETE CURB AND GUTTER, TYPE M-6.06 (SEE HIGHWAY STANDARD 606001)
 - ㉛ PROPOSED COMBINATION CONCRETE CURB AND GUTTER, TYPE M-6.24 (SEE HIGHWAY STANDARD 606001)
 - ㉜ PROPOSED SUBBASE GRANULAR MATERIAL, TYPE A, 10"
 - ㉝ EXISTING AGGREGATE BASE COURSE
 - ㉞ EXISTING COMBINATION CONCRETE CURB AND GUTTER, TYPE M-6.06
 - ㉟ EXISTING CONCRETE MEDIAN SURFACE
 - ㊱ EXISTING AGGREGATE SHOULDERS
 - ㊲ PROPOSED DRILL AND GROUT #6 TIE BARS
 - ㊳ EXISTING COMBINATION CONCRETE CURB AND GUTTER, TYPE M-6.12
 - ㊴ EXISTING CONTINUOUSLY REINFORCED PORTLAND CEMENT CONCRETE PAVEMENT
 - ㊵ PROPOSED HOT-MIX ASPHALT SURFACE COURSE, IL 9.5, MIX D, N70, 1 1/2"
 - ㊶ EXISTING HOT-MIX ASPHALT SURFACE
 - ㊷ EXISTING COMBINATION CONCRETE CURB AND GUTTER, TYPE B-6.24
 - ㊸ PROPOSED PIPE UNDERDRAINS, 4" (SPECIAL)
 - ㊹ PROPOSED LONGITUDINAL JOINT SEALANT
 - ㊺ PROPOSED AGGREGATE BASE COURSE, TYPE A, 12"
 - ㊻ PROPOSED HOT-MIX ASPHALT BINDER COURSE, IL 9.5FG, N70, 1 1/4"
- SEE PLAN SHEETS FOR VARIABLE HORIZONTAL DIMENSIONS.

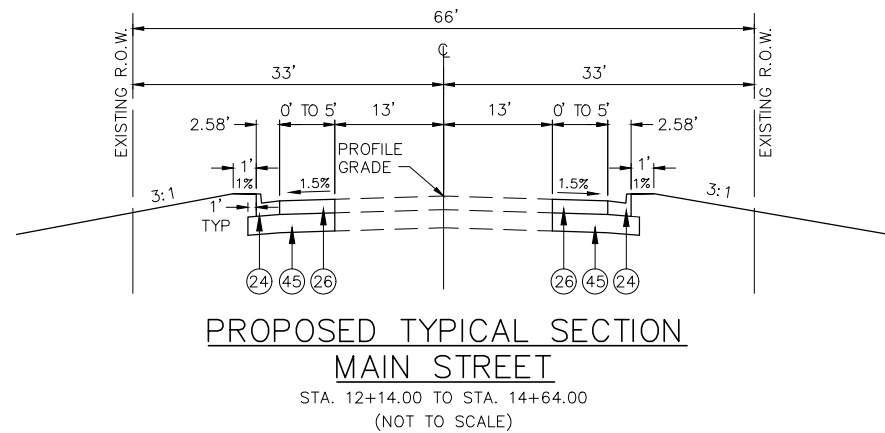
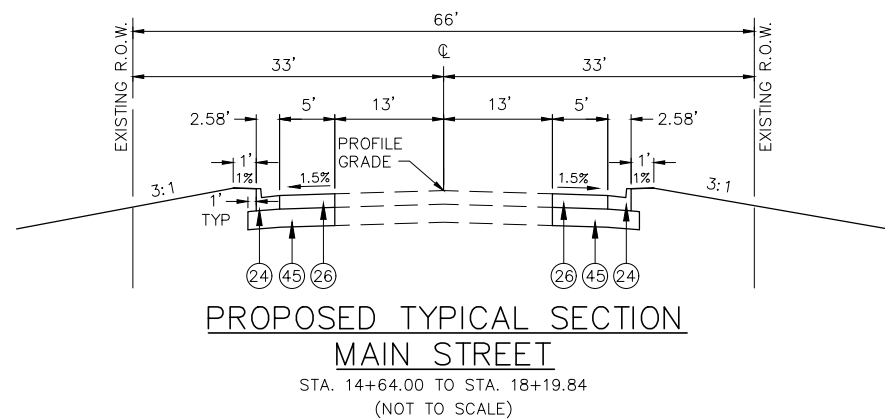
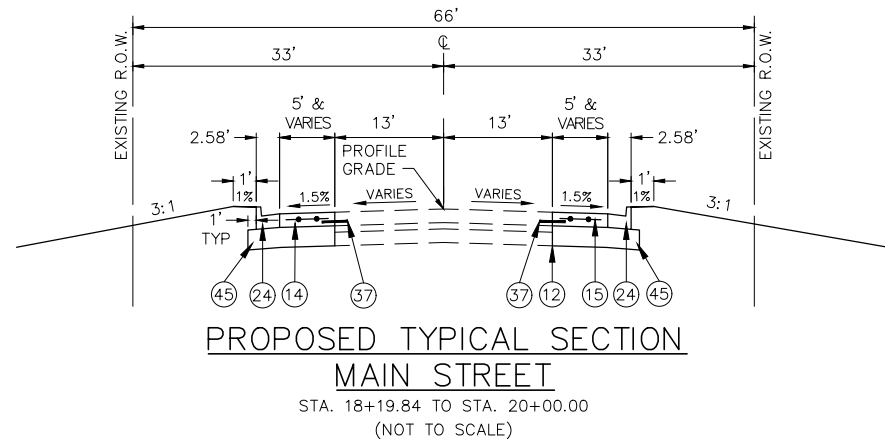

MAIN STREET	
STRUCTURAL DESIGN TRAFFIC:	Year 2016
PV = 4268	SU = 437 MU = 145
ROAD/STREET CLASSIFICATION:	Class II
PERCENTAGE OF STRUCTURAL DESIGN TRAFFIC IN DESIGN LANE:	
P = 50%	S = 50% M = 50%
TRAFFIC FACTOR:	Actual TF = 1.10
	Minimum TF = 0.85
SUBGRADE SUPPORT RATING	
SSR = Poor (ASSUMED)	

F.A.U. RTE.	SECTION	COUNTY	TOTAL SHEETS	SHEET NO.
9330	95-00301-03-PV	ST. CLAIR	166	23
STA.		TO STA.		
FED. ROAD DIST. NO.		ILLINOIS FED. AID PROJECT		
FRANK SCOTT PARKWAY EAST TYPICAL SECTIONS				

CONTRACT NO.: 97372

LEGEND

- ① EXISTING P.C.C. PAVEMENT AND PAVEMENT FABRIC
 - ② EXISTING HOT-MIX ASPHALT SURFACE COURSE
 - ③ EXISTING LIME MODIFIED SOILS
 - ④ EXISTING BITUMINOUS BASE COURSE
 - ⑤ EXISTING STABILIZED SUB-BASE
 - ⑥ EXISTING HOT-MIX ASPHALT BINDER COURSE
 - ⑦ EXISTING AGGREGATE BASE WITH BITUMINOUS SURFACE TREATMENT
 - ⑧ EXISTING HOT-MIX ASPHALT SHOULDERS
 - ⑨ PROPOSED HOT-MIX ASPHALT SHOULDERS, 8"
 - ⑩ PROPOSED PROCESSING MODIFIED SOIL, 12"
 - ⑪ PROPOSED SAWED LONGITUDINAL JOINT (SEE HIGHWAY STANDARD 420001)
 - ⑫ PROPOSED LONGITUDINAL CONSTRUCTION JOINT (SEE HIGHWAY STANDARD 420001)
 - ⑬ PROPOSED SUB-BASE GRANULAR MATERIAL, TYPE A, 4"
 - ⑭ PROPOSED PORTLAND CEMENT CONCRETE PAVEMENT, 9", TYPE A FINAL FINISH
 - ⑮ PROPOSED PAVEMENT WELDED WIRE REINFORCEMENT (SEE HIGHWAY STANDARD 420701)
 - ⑯ PROPOSED AGGREGATE SHOULDER, TYPE B
 - ⑰ PROPOSED CONCRETE GUTTER, TYPE A (SEE HIGHWAY STANDARD 606101)
 - ⑱ PROPOSED CONCRETE MEDIAN SURFACE, 4" (SEE HIGHWAY STANDARD 606301)
 - ⑲ PROPOSED HOT-MIX ASPHALT SURFACE COURSE, MIX D, N70, 1 1/2"
 - ⑳ PROPOSED HOT-MIX ASPHALT BINDER COURSE, IL-19.0, N70, 2 1/4"
 - ㉑ PROPOSED HOT-MIX ASPHALT BASE COURSE, 10 1/4"
 - ㉒ PROPOSED EARTH SHOULDER
 - ㉓ PROPOSED HOT-MIX ASPHALT PAVEMENT (FULL DEPTH), 7" (1 1/2" SURFACE COURSE, 5 1/2" BINDER COURSE) (INITIAL BINDER LIFT THICKNESS = 3")
 - ㉔ PROPOSED COMBINATION CONCRETE CURB & GUTTER, TYPE B-6.24 (SEE HIGHWAY STANDARD 606001)
 - ㉕ PROPOSED HOT-MIX ASPHALT PAVEMENT (FULL DEPTH), 8" (2" SURFACE COURSE, 6" BINDER COURSE) (INITIAL BINDER LIFT THICKNESS = 3.75")
 - ㉖ PROPOSED HOT-MIX ASPHALT PAVEMENT (FULL DEPTH), 10 3/4" (2" SURFACE COURSE, 8 3/4" BINDER COURSE) (INITIAL BINDER LIFT THICKNESS = 4")
 - ㉗ PROPOSED PORTLAND CEMENT CONCRETE PAVEMENT, 8"
 - ㉘ PROPOSED HOT-MIX ASPHALT SURFACE REMOVAL, 1 1/2" AND HOT-MIX ASPHALT SURFACE COURSE, MIX D, N70, 1 1/2"
 - ㉙ PROPOSED AGGREGATE BASE COURSE, TYPE A, 8"
 - ㉚ PROPOSED COMBINATION CONCRETE CURB AND GUTTER, TYPE M-6.06 (SEE HIGHWAY STANDARD 606001)
 - ㉛ PROPOSED COMBINATION CONCRETE CURB AND GUTTER, TYPE M-6.24 (SEE HIGHWAY STANDARD 606001)
 - ㉜ PROPOSED SUBBASE GRANULAR MATERIAL, TYPE A, 10"
 - ㉝ EXISTING AGGREGATE BASE COURSE
 - ㉞ EXISTING COMBINATION CONCRETE CURB AND GUTTER, TYPE M-6.06
 - ㉟ EXISTING CONCRETE MEDIAN SURFACE
 - ㊱ EXISTING AGGREGATE SHOULDERS
 - ㊲ PROPOSED DRILL AND GROUT #6 TIE BARS
 - ㊳ EXISTING COMBINATION CONCRETE CURB AND GUTTER, TYPE M-6.12
 - ㊴ EXISTING CONTINUOUSLY REINFORCED PORTLAND CEMENT CONCRETE PAVEMENT
 - ㊵ PROPOSED HOT-MIX ASPHALT SURFACE COURSE, IL 9.5, MIX D, N70, 1 1/2"
 - ㊶ EXISTING HOT-MIX ASPHALT SURFACE
 - ㊷ EXISTING COMBINATION CONCRETE CURB AND GUTTER, TYPE B-6.24
 - ㊸ PROPOSED PIPE UNDERDRAINS, 4" (SPECIAL)
 - ㊹ PROPOSED LONGITUDINAL JOINT SEALANT
 - ㊺ PROPOSED AGGREGATE BASE COURSE, TYPE A, 12"
 - ㊻ PROPOSED HOT-MIX ASPHALT BINDER COURSE, IL 9.5FG, N70, 1 1/4"
- SEE PLAN SHEETS FOR VARIABLE HORIZONTAL DIMENSIONS.

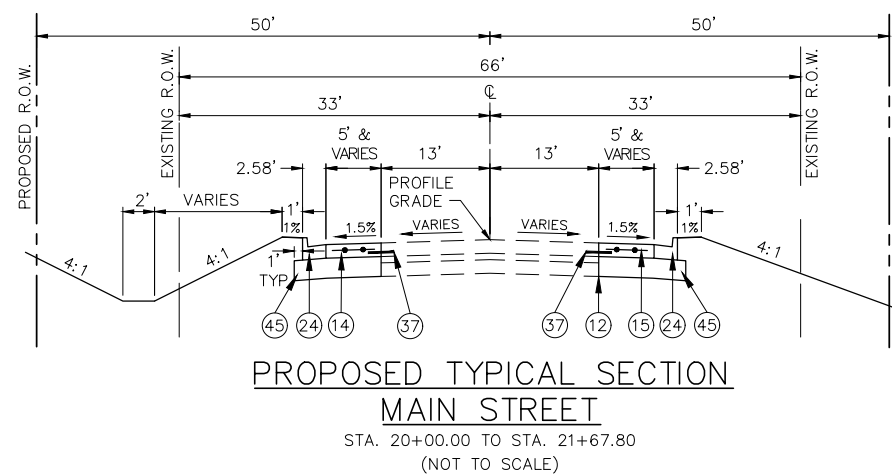
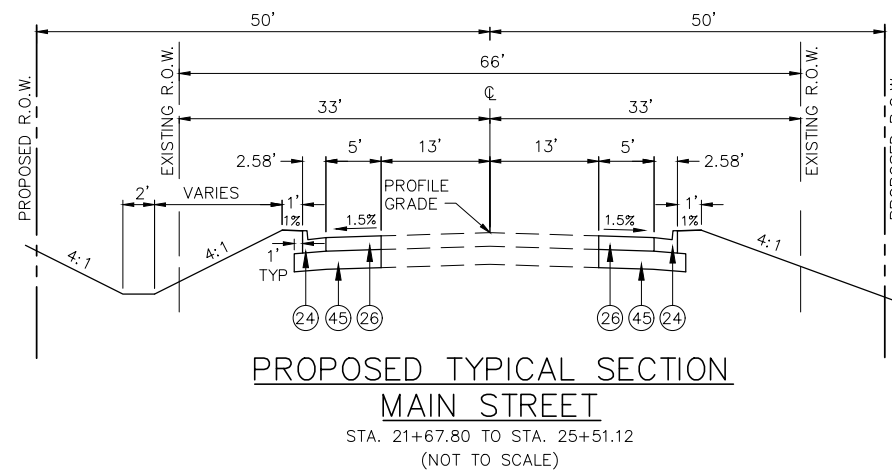
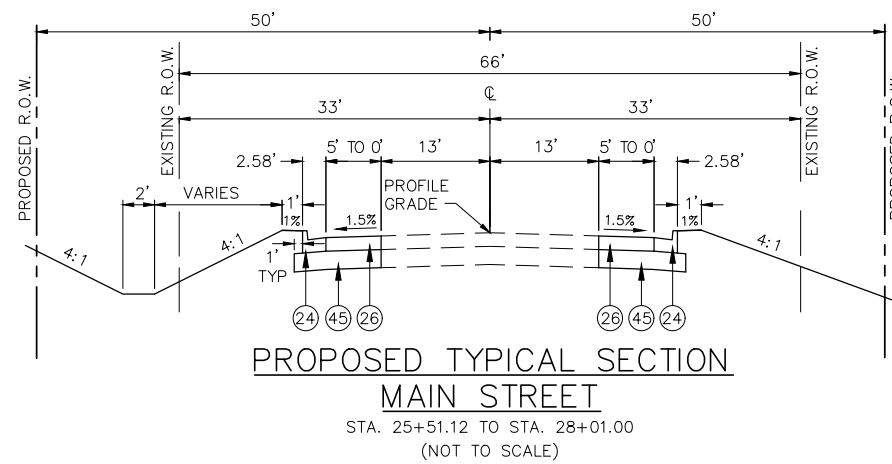

F.A.U. RTE.	SECTION	COUNTY	TOTAL SHEETS	SHEET NO.
9330	95-00301-03-PV	ST. CLAIR	166	24
STA.		TO STA.		
FED. ROAD DIST. NO.		ILLINOIS FED. AID PROJECT		
FRANK SCOTT PARKWAY EAST TYPICAL SECTIONS				

CONTRACT NO.: 97372

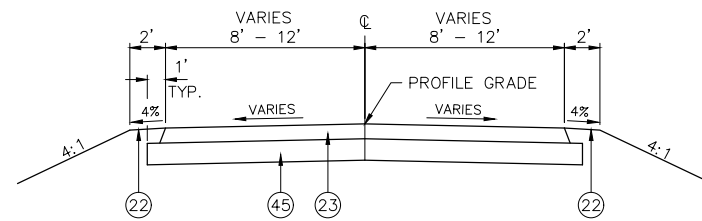

**PROPOSED TYPICAL SECTION
BOBBIE DRIVE**
STA. 11+00.00 TO STA. 11+50.00
(NOT TO SCALE)

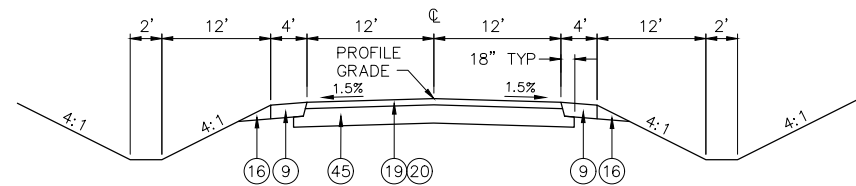

**PROPOSED TYPICAL SECTION
BOBBIE DRIVE**
STA. 10+00.00 TO STA. 11+00.00
(NOT TO SCALE)

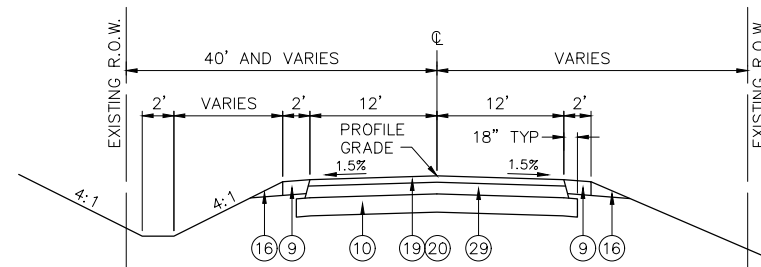

**PROPOSED TYPICAL SECTION
FRONTAGE ROAD**
STA. 50+00.00 TO STA. 57+00.00
(NOT TO SCALE)

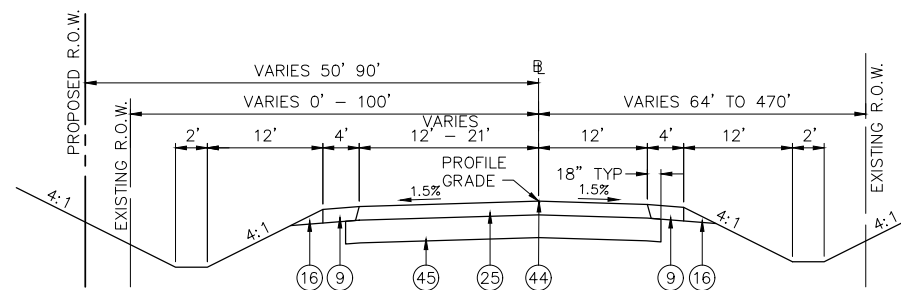

**PROPOSED TYPICAL SECTION
MAPLE STREET**
STA. 45+96.88 TO STA. 50+00.00
(NOT TO SCALE)

MAPLE STREET	
STRUCTURAL DESIGN TRAFFIC:	Year 2024
PV = 1074	SU = 110 MU = 36
ROAD/STREET CLASSIFICATION:	Class II
PERCENTAGE OF STRUCTURAL DESIGN TRAFFIC IN DESIGN LANE:	
P = 50%	S = 50% M = 50%
TRAFFIC FACTOR:	Actual TF = 0.27
	Minimum TF = 0.50
SUBGRADE SUPPORT RATING	
SSR = Poor (ASSUMED)	

LEGEND

- ① EXISTING P.C.C. PAVEMENT AND PAVEMENT FABRIC
 - ② EXISTING HOT-MIX ASPHALT SURFACE COURSE
 - ③ EXISTING LIME MODIFIED SOILS
 - ④ EXISTING BITUMINOUS BASE COURSE
 - ⑤ EXISTING STABILIZED SUB-BASE
 - ⑥ EXISTING HOT-MIX ASPHALT BINDER COURSE
 - ⑦ EXISTING AGGREGATE BASE WITH BITUMINOUS SURFACE TREATMENT
 - ⑧ EXISTING HOT-MIX ASPHALT SHOULDERS
 - ⑨ PROPOSED HOT-MIX ASPHALT SHOULDERS, 8"
 - ⑩ PROPOSED PROCESSING MODIFIED SOIL, 12"
 - ⑪ PROPOSED SAWED LONGITUDINAL JOINT (SEE HIGHWAY STANDARD 420001)
 - ⑫ PROPOSED LONGITUDINAL CONSTRUCTION JOINT (SEE HIGHWAY STANDARD 420001)
 - ⑬ PROPOSED SUB-BASE GRANULAR MATERIAL, TYPE A, 4"
 - ⑭ PROPOSED PORTLAND CEMENT CONCRETE PAVEMENT, 9", TYPE A FINAL FINISH
 - ⑮ PROPOSED PAVEMENT WELDED WIRE REINFORCEMENT (SEE HIGHWAY STANDARD 420701)
 - ⑯ PROPOSED AGGREGATE SHOULDER, TYPE B
 - ⑰ PROPOSED CONCRETE GUTTER, TYPE A (SEE HIGHWAY STANDARD 606101)
 - ⑱ PROPOSED CONCRETE MEDIAN SURFACE, 4" (SEE HIGHWAY STANDARD 606301)
 - ⑲ PROPOSED HOT-MIX ASPHALT SURFACE COURSE, MIX D, N70, 1 1/2"
 - ⑳ PROPOSED HOT-MIX ASPHALT BINDER COURSE, IL-19.0, N70, 2 1/4"
 - ㉑ PROPOSED HOT-MIX ASPHALT BASE COURSE, 10 1/4"
 - ㉒ PROPOSED EARTH SHOULDER
 - ㉓ PROPOSED HOT-MIX ASPHALT PAVEMENT (FULL DEPTH), 7" (1 1/2" SURFACE COURSE, 5 1/2" BINDER COURSE) (INITIAL BINDER LIFT THICKNESS = 3")
 - ㉔ PROPOSED COMBINATION CONCRETE CURB & GUTTER, TYPE B-6.24 (SEE HIGHWAY STANDARD 606001)
 - ㉕ PROPOSED HOT-MIX ASPHALT PAVEMENT (FULL DEPTH), 8" (2" SURFACE COURSE, 6" BINDER COURSE) (INITIAL BINDER LIFT THICKNESS = 3.75")
 - ㉖ PROPOSED HOT-MIX ASPHALT PAVEMENT (FULL DEPTH), 10 3/4" (2" SURFACE COURSE, 8 3/4" BINDER COURSE) (INITIAL BINDER LIFT THICKNESS = 4")
 - ㉗ PROPOSED PORTLAND CEMENT CONCRETE PAVEMENT, 8"
 - ㉘ PROPOSED HOT-MIX ASPHALT SURFACE REMOVAL, 1 1/2" AND HOT-MIX ASPHALT SURFACE COURSE, MIX D, N70, 1 1/2"
 - ㉙ PROPOSED AGGREGATE BASE COURSE, TYPE A, 8"
 - ㉚ PROPOSED COMBINATION CONCRETE CURB AND GUTTER, TYPE M-6.06 (SEE HIGHWAY STANDARD 606001)
 - ㉛ PROPOSED COMBINATION CONCRETE CURB AND GUTTER, TYPE M-6.24 (SEE HIGHWAY STANDARD 606001)
 - ㉜ PROPOSED SUBBASE GRANULAR MATERIAL, TYPE A, 10"
 - ㉝ EXISTING AGGREGATE BASE COURSE
 - ㉞ EXISTING COMBINATION CONCRETE CURB AND GUTTER, TYPE M-6.06
 - ㉟ EXISTING CONCRETE MEDIAN SURFACE
 - ㊱ EXISTING AGGREGATE SHOULDERS
 - ㊲ PROPOSED DRILL AND GROUT #6 TIE BARS
 - ㊳ EXISTING COMBINATION CONCRETE CURB AND GUTTER, TYPE M-6.12
 - ㊴ EXISTING CONTINUOUSLY REINFORCED PORTLAND CEMENT CONCRETE PAVEMENT
 - ㊵ PROPOSED HOT-MIX ASPHALT SURFACE COURSE, IL 9.5, MIX D, N70, 1 1/2"
 - ㊶ EXISTING HOT-MIX ASPHALT SURFACE
 - ㊷ EXISTING COMBINATION CONCRETE CURB AND GUTTER, TYPE B-6.24
 - ㊸ PROPOSED PIPE UNDERDRAINS, 4" (SPECIAL)
 - ㊹ PROPOSED LONGITUDINAL JOINT SEALANT
 - ㊺ PROPOSED AGGREGATE BASE COURSE, TYPE A, 12"
 - ㊻ PROPOSED HOT-MIX ASPHALT BINDER COURSE, IL 9.5FG, N70, 1 1/4"
- SEE PLAN SHEETS FOR VARIABLE HORIZONTAL DIMENSIONS.

F.A.U. RTE.	SECTION	COUNTY	TOTAL SHEETS	SHEET NO.
9330	95-00301-03-PV	ST. CLAIR	166	25
STA.		TO STA.		
FED. ROAD DIST. NO.	ILLINOIS	FED. AID PROJECT		
FRANK SCOTT PARKWAY EAST TYPICAL SECTIONS				

CONTRACT NO.: 97372

LEGEND

- ① EXISTING P.C.C. PAVEMENT AND PAVEMENT FABRIC
 - ② EXISTING HOT-MIX ASPHALT SURFACE COURSE
 - ③ EXISTING LIME MODIFIED SOILS
 - ④ EXISTING BITUMINOUS BASE COURSE
 - ⑤ EXISTING STABILIZED SUB-BASE
 - ⑥ EXISTING HOT-MIX ASPHALT BINDER COURSE
 - ⑦ EXISTING AGGREGATE BASE WITH BITUMINOUS SURFACE TREATMENT
 - ⑧ EXISTING HOT-MIX ASPHALT SHOULDERS
 - ⑨ PROPOSED HOT-MIX ASPHALT SHOULDERS, 8"
 - ⑩ PROPOSED PROCESSING MODIFIED SOIL, 12"
 - ⑪ PROPOSED SAWED LONGITUDINAL JOINT (SEE HIGHWAY STANDARD 420001)
 - ⑫ PROPOSED LONGITUDINAL CONSTRUCTION JOINT (SEE HIGHWAY STANDARD 420001)
 - ⑬ PROPOSED SUB-BASE GRANULAR MATERIAL, TYPE A, 4"
 - ⑭ PROPOSED PORTLAND CEMENT CONCRETE PAVEMENT, 9", TYPE A FINAL FINISH
 - ⑮ PROPOSED PAVEMENT WELDED WIRE REINFORCEMENT (SEE HIGHWAY STANDARD 420701)
 - ⑯ PROPOSED AGGREGATE SHOULDER, TYPE B
 - ⑰ PROPOSED CONCRETE GUTTER, TYPE A (SEE HIGHWAY STANDARD 606101)
 - ⑱ PROPOSED CONCRETE MEDIAN SURFACE, 4" (SEE HIGHWAY STANDARD 606301)
 - ⑲ PROPOSED HOT-MIX ASPHALT SURFACE COURSE, MIX D, N70, 1 1/2"
 - ⑳ PROPOSED HOT-MIX ASPHALT BINDER COURSE, IL-19.0, N70, 2 1/4"
 - ㉑ PROPOSED HOT-MIX ASPHALT BASE COURSE, 10 1/4"
 - ㉒ PROPOSED EARTH SHOULDER
 - ㉓ PROPOSED HOT-MIX ASPHALT PAVEMENT (FULL DEPTH), 7"
(1 1/2" SURFACE COURSE, 5 1/2" BINDER COURSE) (INITIAL BINDER LIFT THICKNESS = 3")
 - ㉔ PROPOSED COMBINATION CONCRETE CURB & GUTTER, TYPE B-6.24
(SEE HIGHWAY STANDARD 606001)
 - ㉕ PROPOSED HOT-MIX ASPHALT PAVEMENT (FULL DEPTH), 8"
(2" SURFACE COURSE, 6" BINDER COURSE) (INITIAL BINDER LIFT THICKNESS = 3.75")
 - ㉖ PROPOSED HOT-MIX ASPHALT PAVEMENT (FULL DEPTH), 10 3/4"
(2" SURFACE COURSE, 8 3/4" BINDER COURSE) (INITIAL BINDER LIFT THICKNESS = 4")
 - ㉗ PROPOSED PORTLAND CEMENT CONCRETE PAVEMENT, 8"
 - ㉘ PROPOSED HOT-MIX ASPHALT SURFACE REMOVAL, 1 1/2" AND HOT-MIX ASPHALT SURFACE COURSE, MIX D, N70, 1 1/2"
 - ㉙ PROPOSED AGGREGATE BASE COURSE, TYPE A, 8"
 - ㉚ PROPOSED COMBINATION CONCRETE CURB AND GUTTER, TYPE M-6.06
(SEE HIGHWAY STANDARD 606001)
 - ㉛ PROPOSED COMBINATION CONCRETE CURB AND GUTTER, TYPE M-6.24
(SEE HIGHWAY STANDARD 606001)
 - ㉜ PROPOSED SUBBASE GRANULAR MATERIAL, TYPE A, 10"
 - ㉝ EXISTING AGGREGATE BASE COURSE
 - ㉞ EXISTING COMBINATION CONCRETE CURB AND GUTTER, TYPE M-6.06
 - ㉟ EXISTING CONCRETE MEDIAN SURFACE
 - ㊱ EXISTING AGGREGATE SHOULDERS
 - ㊲ PROPOSED DRILL AND GROUT #6 TIE BARS
 - ㊳ EXISTING COMBINATION CONCRETE CURB AND GUTTER, TYPE M-6.12
 - ㊴ EXISTING CONTINUOUSLY REINFORCED PORTLAND CEMENT CONCRETE PAVEMENT
 - ㊵ PROPOSED HOT-MIX ASPHALT SURFACE COURSE, IL 9.5, MIX D, N70, 1 1/2"
 - ㊶ EXISTING HOT-MIX ASPHALT SURFACE
 - ㊷ EXISTING COMBINATION CONCRETE CURB AND GUTTER, TYPE B-6.24
 - ㊸ PROPOSED PIPE UNDERDRAINS, 4" (SPECIAL)
 - ㊹ PROPOSED LONGITUDINAL JOINT SEALANT
 - ㊺ PROPOSED AGGREGATE BASE COURSE, TYPE A, 12"
 - ㊻ PROPOSED HOT-MIX ASPHALT BINDER COURSE, IL 9.5FG, N70, 1 1/4"
- SEE PLAN SHEETS FOR VARIABLE HORIZONTAL DIMENSIONS.

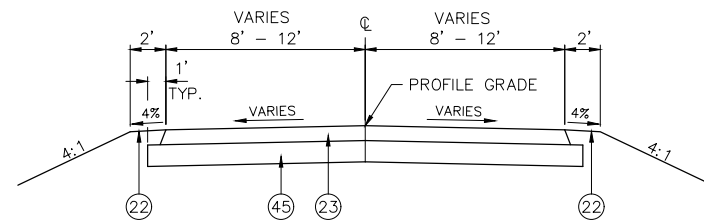

PROPOSED TYPICAL SECTION OLD O'FALLON ROAD

STA. 193+67.35 LT TO STA. 194+10.02 LT (CROSS ST. STATIONING)
(NOT TO SCALE)

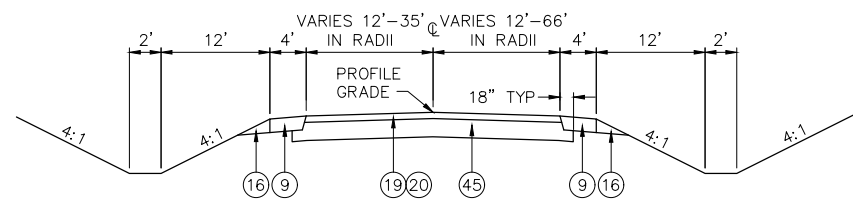

PROPOSED TYPICAL SECTION OLD O'FALLON ROAD

STA. 193+32.09 LT TO STA. 193+67.35 LT (CROSS ST. STATIONING)
(NOT TO SCALE)

F.A.U. RTE.	SECTION	COUNTY	TOTAL SHEETS	SHEET NO.
9330	95-00301-03-PV	ST. CLAIR	166	26
STA.	TO STA.			
FED. ROAD DIST. NO.	ILLINOIS	FED. AID PROJECT		
FRANK SCOTT PARKWAY EAST TYPICAL SECTIONS				

CONTRACT NO.: 97372

LEGEND

- ① EXISTING P.C.C. PAVEMENT AND PAVEMENT FABRIC
- ② EXISTING HOT-MIX ASPHALT SURFACE COURSE
- ③ EXISTING LIME MODIFIED SOILS
- ④ EXISTING BITUMINOUS BASE COURSE
- ⑤ EXISTING STABILIZED SUB-BASE
- ⑥ EXISTING HOT-MIX ASPHALT BINDER COURSE
- ⑦ EXISTING AGGREGATE BASE WITH BITUMINOUS SURFACE TREATMENT
- ⑧ EXISTING HOT-MIX ASPHALT SHOULDERS
- ⑨ PROPOSED HOT-MIX ASPHALT SHOULDERS, 8"
- ⑩ PROPOSED PROCESSING MODIFIED SOIL, 12"
- ⑪ PROPOSED SAWED LONGITUDINAL JOINT (SEE HIGHWAY STANDARD 420001)
- ⑫ PROPOSED LONGITUDINAL CONSTRUCTION JOINT (SEE HIGHWAY STANDARD 420001)
- ⑬ PROPOSED SUB-BASE GRANULAR MATERIAL, TYPE A, 4"
- ⑭ PROPOSED PORTLAND CEMENT CONCRETE PAVEMENT, 9", TYPE A FINAL FINISH
- ⑮ PROPOSED PAVEMENT WELDED WIRE REINFORCEMENT (SEE HIGHWAY STANDARD 420701)
- ⑯ PROPOSED AGGREGATE SHOULDER, TYPE B
- ⑰ PROPOSED CONCRETE GUTTER, TYPE A (SEE HIGHWAY STANDARD 606101)
- ⑱ PROPOSED CONCRETE MEDIAN SURFACE, 4" (SEE HIGHWAY STANDARD 606301)
- ⑲ PROPOSED HOT-MIX ASPHALT SURFACE COURSE, MIX D, N70, 1 1/2"
- ⑳ PROPOSED HOT-MIX ASPHALT BINDER COURSE, IL-19.0, N70, 2 1/4"
- ㉑ PROPOSED HOT-MIX ASPHALT BASE COURSE, 10 1/4"
- ㉒ PROPOSED EARTH SHOULDER
- ㉓ PROPOSED HOT-MIX ASPHALT PAVEMENT (FULL DEPTH), 7"
(1 1/2" SURFACE COURSE, 5 1/2" BINDER COURSE) (INITIAL BINDER LIFT THICKNESS = 3")
- ㉔ PROPOSED COMBINATION CONCRETE CURB & GUTTER, TYPE B-6.24
(SEE HIGHWAY STANDARD 606001)
- ㉕ PROPOSED HOT-MIX ASPHALT PAVEMENT (FULL DEPTH), 8"
(2" SURFACE COURSE, 6" BINDER COURSE) (INITIAL BINDER LIFT THICKNESS = 3.75")
- ㉖ PROPOSED HOT-MIX ASPHALT PAVEMENT (FULL DEPTH), 10 3/4"
(2" SURFACE COURSE, 8 3/4" BINDER COURSE) (INITIAL BINDER LIFT THICKNESS = 4")
- ㉗ PROPOSED PORTLAND CEMENT CONCRETE PAVEMENT, 8"
- ㉘ PROPOSED HOT-MIX ASPHALT SURFACE REMOVAL, 1 1/2" AND HOT-MIX ASPHALT SURFACE COURSE, MIX D, N70, 1 1/2"
- ㉙ PROPOSED AGGREGATE BASE COURSE, TYPE A, 8"
- ㉚ PROPOSED COMBINATION CONCRETE CURB AND GUTTER, TYPE M-6.06
(SEE HIGHWAY STANDARD 606001)
- ㉛ PROPOSED COMBINATION CONCRETE CURB AND GUTTER, TYPE M-6.24
(SEE HIGHWAY STANDARD 606001)
- ㉜ PROPOSED SUBBASE GRANULAR MATERIAL, TYPE A, 10"
- ㉝ EXISTING AGGREGATE BASE COURSE
- ㉞ EXISTING COMBINATION CONCRETE CURB AND GUTTER, TYPE M-6.06
- ㉟ EXISTING CONCRETE MEDIAN SURFACE
- ㊱ EXISTING AGGREGATE SHOULDERS
- ㊲ PROPOSED DRILL AND GROUT #6 TIE BARS
- ㊳ EXISTING COMBINATION CONCRETE CURB AND GUTTER, TYPE M-6.12
- ㊴ EXISTING CONTINUOUSLY REINFORCED PORTLAND CEMENT CONCRETE PAVEMENT
- ㊵ PROPOSED HOT-MIX ASPHALT SURFACE COURSE, IL 9.5, MIX D, N70, 1 1/2"
- ㊶ EXISTING HOT-MIX ASPHALT SURFACE
- ㊷ EXISTING COMBINATION CONCRETE CURB AND GUTTER, TYPE B-6.24
- ㊸ PROPOSED PIPE UNDERDRAINS, 4" (SPECIAL)
- ㊹ PROPOSED LONGITUDINAL JOINT SEALANT
- ㊺ PROPOSED AGGREGATE BASE COURSE, TYPE A, 12"
- ㊻ PROPOSED HOT-MIX ASPHALT BINDER COURSE, IL 9.5FG, N70, 1 1/4"
SEE PLAN SHEETS FOR VARIABLE HORIZONTAL DIMENSIONS.

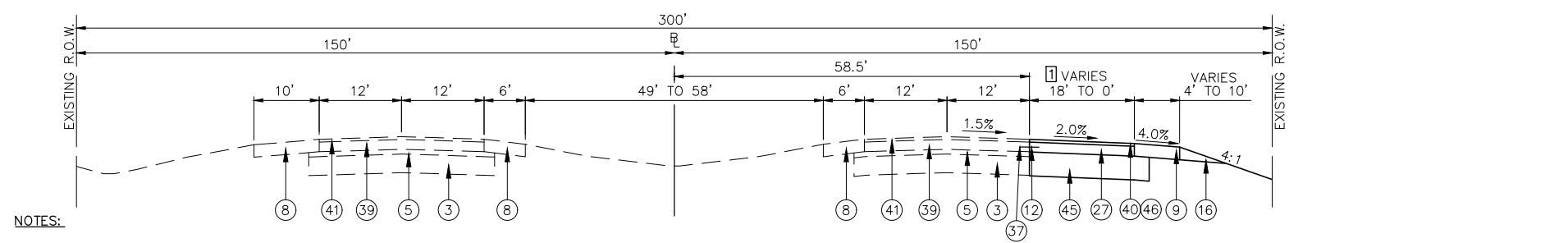

**PROPOSED TYPICAL SECTION
IL ROUTE 158**

STA. 207+65.00 TO STA. 213+78.92
(NOT TO SCALE)

NOTES:
 1 PAVEMENT WIDTH CHANGES FROM:
 18' TO 12' FROM STA 207+65.00 TO STA 211+13.92
 12' TO 0' FROM STA 211+13.92 TO STA 213+56.83
 SEE PLANS

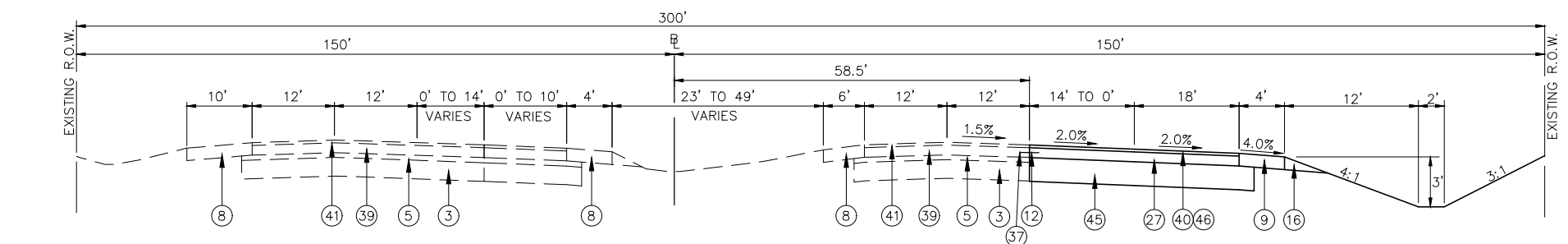

**PROPOSED TYPICAL SECTION
IL ROUTE 158**

STA. 199+54.00 TO STA. 207+65.00
OMIT FRANK SCOTT PARKWAY EAST INTERSECTION STA. 196+45.96 TO STA. 199+73.92
(NOT TO SCALE)

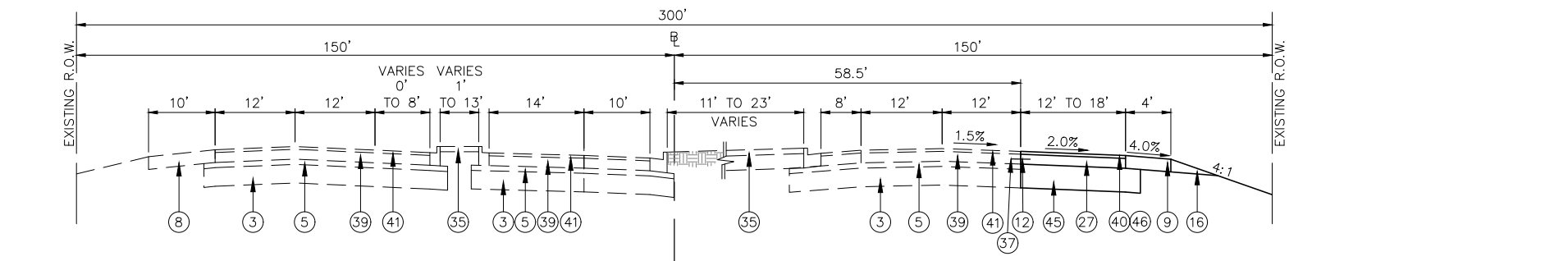

**PROPOSED TYPICAL SECTION
IL ROUTE 158**

STA. 195+00.96 TO STA. 196+52.13
(NOT TO SCALE)

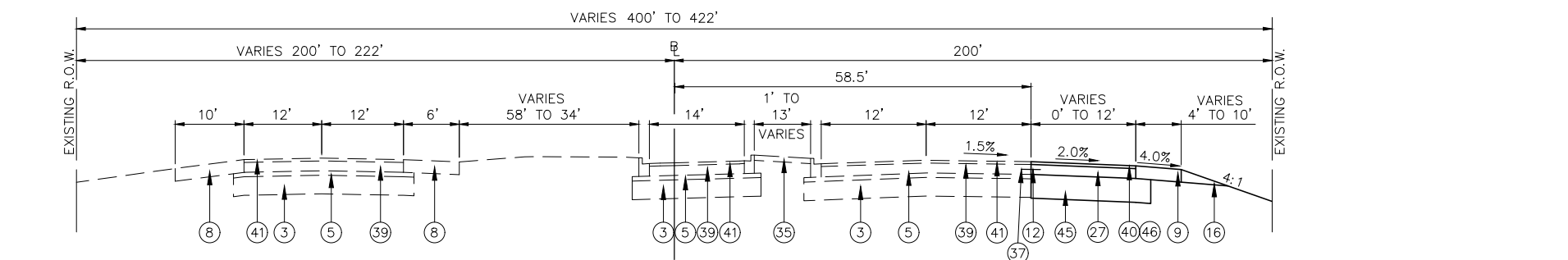

**PROPOSED TYPICAL SECTION
IL ROUTE 158**

STA. 192+35.96 TO STA. 195+00.96
(NOT TO SCALE)

EARTHWORK

STATION	STATION	EARTH EXCAVATION (SPECIAL) (CU YD)	EARTH EXCAVATION ADJUSTED FOR SHRINKAGE (CU YD)	EMBANKMENT (CU YD)	EARTHWORK BALANCE WASTE (+) OR SHORTAGE (-) (CU YD)	FURNISHED EXCAVATION (CU YD)
FRANK SCOTT PARKWAY EAST						
160+79	251+50	43,475	32,605	124,815	-92,210	
CROSS STREET						
187+00	199+00	2,160	1,620	1,510	115	
MAIN STREET						
12+14	28+01	2,085	1,565	655	910	
MAPLE STREET						
45+97	50+00	1,280	960	860	100	
FRONTAGE ROAD						
50+00	57+50	2,145	1,610	815	795	
BOBBIE DRIVE						
10+00	11+50	35	25	675	-650	
ILLINOIS STATE ROUTE 158						
192+00	214+00	1,645	1,235	1,050	185	
TOTAL		52,825	39,620	130,380	-90,755	113,444

EARTHWORK NOTES:

- ESTIMATED SHRINKAGE FACTOR = 25%
- APPROXIMATE EMBANKMENT QUANTITY IS SHOWN FOR INFORMATION ONLY.
- BORROW EXCAVATION FACTOR = 25%

TREE REMOVAL

STATION	STATION	OFFSET	TREE REMOV 6-16 (UNIT)	TREE REMOV OVER 15 (UNIT)	TREE REMOV ACRES (ACRE)
FRANK SCOTT PARKWAY EAST					
164+89	165+46				0.25
165+25	178+70				4.75
179+42	180+03				0.25
183+12	186+56				0.75
204+75	205+99				0.25
226+55	234+43				3.00
CROSS STREET					
190+74		RT		18	
191+28		RT		16	
193+91		LT	14		
194+02		LT	14		
MAIN STREET					
13+02		RT	12		
13+20		RT	12		
FRONTAGE ROAD					
52+93		RT	6		
55+23		LT	6		
56+69		LT		26	
TOTAL			64	60	9.25

ENTRANCE

STATION (NOTE 1)	OFFSET	ENTRANCE TYPE	ENTRANCE WIDTH "W" (NOTE 1) (FOOT)	ENTRANCE DEPTH "D" (FOOT)	EXISTING SURFACE TYPE	AGG BASE CSE A 4 (SQ YD)	AGG BASE CSE A 6 (SQ YD)	AGG SURF CSE A 6 (SQ YD)	INCIDENTAL HMA SURF (TON)	PCC DRIVEWAY PAVT 6 (NOTE 2) (SQ YD)	DRIVEWAY PAVEMENT REM (SQ YD)
FRANK SCOTT PARKWAY EAST											
181+00	LT	F.E.	20	24	EARTH						
194+00	LT	F.E.	20	28	EARTH						
226+00	LT	F.E.	20	28	EARTH						
226+00	RT	F.E.	20	28	EARTH						
244+00	RT	F.E.	20	70	EARTH						
245+90	RT	C.E.	35	58	ASPHALT		237		26.0		178
247+44	RT	C.E.	35	50	ASPHALT		145		16.0		163
CROSS STREET											
188+35	RT	P.E.	20	75	ASPHALT	165			18.0		195
192+20	RT	P.E.	20	65	ASPHALT	149			17.0		194
MAIN STREET											
12+32	LT	P.E.	12	11.5	AGG			19		14	14
12+74	LT	P.E.	12	0	AGG			16		16	18
15+69	LT	P.E.	24	6.5	AGG			17		19	18
16+26	LT	P.E.	16	6.5	AGG			9		14	14
16+64	RT	F.E.	20	6.5	EARTH					17	16
24+72	RT	F.E.	20	6.5	EARTH					17	16
FRONTAGE ROAD											
50+75	LT	F.E.	20	46	EARTH						
52+39	LT	C.E.	24	38	AGG			181			
53+06	LT	C.E.	24	27	ASPHALT				76		78
TOTAL						314	458	242	85	97	904

ENTRANCE NOTES:

- PRIOR TO CONSTRUCTION, THE ENGINEER WILL CONTACT EACH PROPERTY OWNER AND VERIFY THE LOCATION AND WIDTH OF ALL ENTRANCES. THE CONTRACTOR SHALL CONFIRM THE FINAL LOCATIONS AND WIDTHS WITH THE ENGINEER PRIOR TO CONSTRUCTION. SEE CONSTRUCTION DETAILS SHEET FOR ENTRANCE DETAILS.
- INCIDENTAL HOT-MIX ASPHALT SURFACING QUANTITY IS CALCULATED AT A RATE OF 0.056 TON/SQ YD/INCH. BITUMINOUS MATERIALS (PRIME COAT) AND AGGREGATE (PRIME COAT) ARE REQUIRED BUT WILL NOT BE MEASURED SEPARATELY FOR PAYMENT. THE COST FOR BITUMINOUS MATERIALS AND AGGREGATE SHALL BE INCLUDED IN THE CONTRACT UNIT PRICE FOR INCIDENTAL HOT-MIX ASPHALT SURFACING.
- DEPRESSED CURB AND GUTTER THROUGH ENTRANCES SHALL BE MEASURED FOR PAYMENT AS COMBINATION CONCRETE CURB AND GUTTER, TYPE B-6.24.

CURB & GUTTER

STATION	STATION	OFFSET	SUB GRAN MAT A 10 (SQ YD)	COMB CURB GUTTER REM (FOOT)	MEDIAN REMDVAL (SQ FT)	PAVED DITCH REMDVAL (FOOT)	CLASS I CONC CONC OUTLET (CU YD)	CONC GUTTER TA (FOOT)	COMB CC&G TB6.24 (FOOT)	COMB CC&G TM6.24 (FOOT)	CONC MEDIAN TSM6.12 (FOOT)	CONC MEDIAN SURF 4 (SQ FT)
FRANK SCOTT PARKWAY EAST												
160+79	161+94	LT/RT		16					186			
242+12	251+42	LT/RT	323		2,996		5.3	565		391	947	2,895
CROSS STREET												
185+00	198+21	RT					4.7	309	81			
MAIN STREET												
12+14	28+01	LT/RT			1,587					1,544		
12+14	28+01	LT/RT			1,590					1,599		
MAPLE STREET												
45+96	50+00	LT				193						
TOTAL			323	3,193	2,996	193	10.0	874	3,410	391	947	2,895

STORM SEWER TO BE FILLED

STATION	STATION	OFFSET	REMOV MANHOLES (EACH)	REMOV INLETS (EACH)	FILL MANHOLES (EACH)	STORM SEWER FILLED (FOOT)
MAIN STREET						
12+80	13+68	RT				25
13+68		RT			1	
13+68	14+20	RT				52
14+20		RT		1		
14+20		LT		1		
16+46		RT		1		
16+46		LT		1		
16+56		LT	1			
18+16		LT			1	
18+16		RT			1	
18+16		LT/RT				28
18+16	19+20	LT				98
19+15		LT			1	
19+15		RT			1	
19+20	19+27	LT				7
19+27		LT			1	
19+27		RT			1	
19+27		LT/RT				28
19+27	19+34	LT				8
19+27	19+34	RT				8
19+32		LT			1	
19+32		RT			1	
19+32	20+40	LT				110
19+32	19+55	RT				23
19+55		RT			1	
20+40		LT			1	
20+40		RT			1	
20+40		LT/RT				28
20+40	22+45	LT				203
22+45		LT			1	
22+45		RT			1	
22+45	23+95	LT				159
23+95		LT			1	
23+95		RT			1	
23+95	24+40	LT				46
25+45		LT			1	
25+45		RT			1	
25+45		LT	1			
26+95		LT			1	
26+95		RT			1	
26+95		LT	1			
FRANK SCOTT PARKWAY EAST						
248+18		RT			1	
TOTAL			3	11	14	823

NOTES:

- SAWCUTTING AROUND INLET REMOVAL TO BE INCLUDED IN THE COST OF PAVEMENT REMOVAL.

CULVERT / STORM SEWER REMOVAL

STATION	STATION	OFFSET	SIZE (INCHES)	EXISTING CULVERT TYPE	CONC HDWL REM (EACH)	PIPE CUL REMOV (NOTE 1) (FOOT)	STORM SEWER REMOV 12 (NOTE 1) (FOOT)	STORM SEWER REMOV 18 (NOTE 1) (FOOT)	STORM SEW REMOV 24 (NOTE 1) (FOOT)
FRANK SCOTT PARKWAY EAST									
185+23		RT	24	RCP		30			
243+21		RT	36	RCP		105			
244+24		RT	30	CMP		55			
245+90		RT	15	CMP		68			
247+44		RT	21	CMP		57			
248+18		RT	12	RCP			50		
CROSS STREET									
187+99		RT	18	CMP		44			
191+40		RT	15	CMP		25			
192+59		RT	12	CMP		45			
193+33		LT	12	CMP		36			
MAIN STREET									
12+80	20+00	LT/RT	VARIOUS	RCP			86	450	51
16+09		CL	4'X3'	BOX	2				
20+00	24+40	LT/RT	VARIOUS	RCP					
IL 158									
202+49		RT	42	RCP	1				
TOTAL					3	465	136	450	51

CULVERT REMOVAL NOTES:

1. THE COST FOR TRENCH BACKFILL REQUIRED FOR PIPE CULVERT & STORM SEWER REMOVAL SHALL BE INCLUDED IN THE CONTRACT UNIT PRICE FOR PIPE CULVERT REMOVAL & STORM SEWER REMOVAL, PIPE SIZE SPECIFIED.

PIPE UNDERDRAINS

STATION	STATION	OFFSET	CONC HDWL FOR P DRAIN (EACH)	PIPE UNDERDRAIN 4 SP (FOOT)	PIPE UNDERDR T 14 (FOOT)	OUTLET AT STATION
FRANK SCOTT PARKWAY EAST						
185+00	189+00	RT	1	14	400	189+00
189+10	193+00	RT	1	14	390	193+00
193+10	197+00	RT	1	14	390	197+00
197+00	200+00	LT/RT	2	28	580	200+00
202+00	206+39	LT/RT	2	28	878	206+39 (SAG)
206+50	209+90	RT		14	340	
210+00	213+90	RT	1	14	390	210+00
214+00	217+90	RT	1	14	390	214+00
218+00	221+90	LT/RT	2	28	780	218+00
222+00	226+50	LT/RT	2	28	900	222+00
TOTAL			13	196	5438	

F.A.U. RTE.	SECTION	COUNTY	TOTAL SHEETS	SHEET NO.
9330	95-00301-03-PV	ST. CLAIR	166	28
STA. X		TO STA. X		
FED. ROAD DIST. NO.	ILLINOIS	FED. AID PROJECT		
SCHEDULES				

CONTRACT NO.: 97372

PAVEMENT

STATION	STATION	PROCESS MOD SOIL 12 (SQ YD)	PORTLAND CEMENT (TON)	SUB GRAN MAT A 4 (SQ YD)	AGG BASE CSE A 8 (SQ YD)	AGG BASE CSE A 12 (SQ YD)	HMA BASE CSE 10 1/4 (SQ YD)	HMA BC IL-19.0 N70 (TON)	BIT MATLS PR CT (POUND)	BIT MATLS TACK CT (POUND)	LONG JOINT SEALANT (FOOT)	HMA BC IL-9.5FG N70 (TON)	HMA SC IL-9.5 D N70 (TON)	HMA PAVT FD 7 (SQ YD)	HMA PAVT FD 8 (SQ YD)	HMA PAVT FD 10 3/4 (SQ YD)	PCC PVT 9 (SQ YD)	WELDED WIRE REINF (SQ YD)	PROTECTIVE COAT (SQ YD)	PCC PVT 8 (SQ YD)	PAVEMENT REM (SQ YD)	HMA SURF REM 1 1/2 (SQ YD)	PAVED SHLD REMOVAL (SQ YD)	AGGREGATE SHLDS B (TON)	HMA SHOULDERS 8 (SQ YD)	DRILL-GROUT #6 T-BAR (EACH)	
FRANK SCOTT PARKWAY EAST																											
160+79	161+94					281											169	223	223				144				205
161+94	200+85	16,486	426.4	16,486						1,833							15,191	15,191	15,191		249		226	638	8,145		
200+85	242+12	14,851	384.1	14,851						1,931							13,459	13,459	13,459					634	8,580		
242+12	251+54	5,021	129.9	5,021		2,408				335							6,502	6,502	6,707		2,375			130	1,491		
CROSS STREET																											
185+00	195+75	776	20.1			1,695	2,299	246.0		3,442	3,984								144			302	4,446	1,775	155	1,522	
MAIN STREET																											
12+14	19+17					1,349				120						630	159	159	602			12					120
20+72	28+01					1,298				149						563	159	159	618			18					112
MAPLE STREET																											
45+96	49+86					1,560				401	388				1,454							6,167		1,389	54	329	
BOBBIE DRIVE																											
10+13	11+50					442		34.0	674	109			23	126								158			10	90	
FRONTAGE ROAD																											
50+25	57+57	2,164	56.0		1,848			233.0	4,159	88			155												110	305	
ILLINOIS ROUTE 158																											
192+58	196+45					461				49		29	34						409	409			455	34	217	187	
199+79	213+57					3,182				151	2,143	212	254						3,022	3,011			1,555	118	672	527	
TOTAL		39,298	1,016.5	36,358	1,848	12,676	2,299	513	4,833	8,608	6,515	241	1,004	126	1,454	1,193	35,639	35,693	40,375	3,420	9,281	4,446	5,544	1,883	21,351	1,151	

PAVEMENT NOTES:

1. CEMENT QUANTITY IS CALCULATED USING AN ASSUMED RATE OF 0.0776 TON/CU YD. THE ACTUAL CEMENT APPLICATION RATE WILL BE DETERMINED BY THE ENGINEER AND WILL BE BASED ON TESTS OF CEMENT AND SOIL SAMPLES PROVIDED BY THE ENGINEER.
2. HMA BINDER AND SURFACE QUANTITIES ARE CALCULATED AT A RATE OF 112 LB/SQ YD/IN. THICKNESS.
3. PAVEMENT QUANTITIES FOR JULIUS DRIVE ARE INCLUDED IN THE MAIN STREET QUANTITIES.
4. PAVEMENT QUANTITIES FOR OLD O'FALLON ROAD (NORTH EAST LEG) ARE INCLUDED IN THE CROSS STREET QUANTITIES.

FINAL SURVEY PLOTTED
NOTE BOOK TEMPLATE
AREAS CHECKED

ORIGINAL SURVEY PLOTTED
NOTE BOOK TEMPLATE
AREAS CHECKED

F.A.U. RTE.	SECTION	COUNTY	TOTAL SHEETS	SHEET NO.
9330	95-00301-03-PV	ST. CLAIR	166	29
STA. X	TO STA. X			
FED. ROAD DIST. NO.	ILLINOIS	FED. AID PROJECT		
SCHEDULES				

CONTRACT NO.: 97372

BY	DATE
FINAL SURVEYED	
SURVEY PLOTTED	
NOTE BOOK TEMPLATE	
AREAS CHECKED	
NO.	

BY	DATE
ORIGINAL SURVEYED	
SURVEY PLOTTED	
NOTE BOOK TEMPLATE	
AREAS CHECKED	
NO.	

SIGN

STATION	OFFSET	TYPE	DESCRIPTION	SIZE (FT X FT)	SIGN PANEL T1 (SQ FT)	SIGN PANEL T2 (SQ FT)	TELES STL SIN SUPPORT (FOOT)	BASE TEL STL SIN SUPP (EACH)	NOTES
FRANK SCOTT PARKWAY EAST									
156+88	RT	R3-7R	RIGHT LANE MUST TURN RIGHT	3 X 3	9		13	1	
161+14	LT	R10-12	LEFT TURN YIELD ON GREEN	2.5 X 3	7.5				MOUNT ON MAST ARM
161+14	LT	D3-1	CROSS STREET	1.5 X 5.5	8.3				MOUNT ON MAST ARM
161+78	RT	D3-1	FRANK SCOTT PARKWAY EAST	2.5 X 6	15				MOUNT ON MAST ARM
161+89	RT	R10-12	LEFT TURN YIELD ON GREEN	2.5 X 3	7.5				MOUNT ON MAST ARM
161+95	LT	R10-12	LEFT TURN YIELD ON GREEN	2.5 X 3	7.5				MOUNT ON MAST ARM
162+01	LT	D3-1	FRANK SCOTT PARKWAY EAST	2.5 X 6	15				MOUNT ON MAST ARM
162+57	RT	D3-1	CROSS STREET	1.5 X 5.5	8.3				MOUNT ON MAST ARM
162+57	RT	R10-12	LEFT TURN YIELD ON GREEN	2.5 X 3	7.5				MOUNT ON MAST ARM
164+74	RT	R2-1	SPEED LIMIT	3 X 2.5	7.5		12	1	
165+05	LT	R3-1100a	RIGHT TURN LANE	2 X 2	4		12	1	
198+35	LT	R2-1	SPEED LIMIT	3 X 2.5	7.5		12	1	
200+41	RT	D3-1	FRANK SCOTT PARKWAY EAST	2.5 X 6		15			MOUNT ON MAST ARM
200+58	LT	D3-1	MAIN STREET	1.5 X 5	7.5				MOUNT ON MAST ARM
200+58	LT	R10-12	LEFT TURN YIELD ON GREEN	2.5 X 3	7.5				MOUNT ON MAST ARM
200+60	RT	R10-12	LEFT TURN YIELD ON GREEN	2.5 X 3	7.5				MOUNT ON MAST ARM
201+07	RT	R10-12	LEFT TURN YIELD ON GREEN	2.5 X 3	7.5				MOUNT ON MAST ARM
201+07	RT	D3-1	MAIN STREET	1.5 X 5	7.5				MOUNT ON MAST ARM
201+07	LT	R10-12	LEFT TURN YIELD ON GREEN	2.5 X 3	7.5				MOUNT ON MAST ARM
201+22	LT	D3-1	FRANK SCOTT PARKWAY EAST	2.5 X 6		15			MOUNT ON MAST ARM
203+30	RT	R2-1	SPEED LIMIT	3 X 2.5	7.5		12	1	
245+39	RT	R3-1100a	RIGHT TURN LANE	2 X 2	4		12	1	
247+36	LT	W4-2	LANE ENDS	3 X 3	9		13	1	
249+13	LT	W9-1	RIGHT LANE ENDS	3 X 3	9		13	1	
250+70	CL	R4-7a	KEEP RIGHT	2 X 2.5	5		12	1	LOCATED ON MEDIAN
251+00	RT		RIGHT TURN WITHOUT STOPPING	2.5 X 3	7.5				BRACKET MOUNT ON MAST ARM
251+10	RT	D3-2	FSPE / WHERRY ROAD	4 X 6		24			MOUNT ON MAST ARM
253+00	LT	D3-2	FSPE / WHERRY ROAD	4 X 6		24			MOUNT ON MAST ARM
CROSS STREET									
191+91	RT	R3-1100a	RIGHT TURN LANE	2 X 2	4		12	1	
MAPLE STREET									
44+96	RT	W1-2L	LEFT CURVE	2.5 X 2.5	6.25		13	1	
44+96	RT	W13-1P	30 MPH	1.5 X 1.5	2.25				
47+77	RT	W3-1	STOP SIGN AHEAD	2.5 X 2.5	6.25		13	1	
49+66	RT	R1-1	STOP	2.5 X 2.5	6.25		13	1	
FRONTAGE ROAD									
50+38	RT	R1-1	STOP	2.5 X 2.5	6.25		13	1	
IL 158									
194+89	RT	R3-1100a	RIGHT TURN LANE	2 X 2	4		12	1	
194+89	RT	I1-103	SHILOH CITY LIMIT	4 X 2	8				
195+05	RT	R3-1100a	RIGHT TURN LANE	2 X 2	4		12	1	
197+00	LT	R4-7a	KEEP RIGHT	2 X 2.5	5		12	1	
204+00	CL	R3-1100a	LEFT TURN LANE	2 X 2	4		12	1	
208+18	LT	W16-8aP	FSPE/WHERRY ROAD	1.25 X 6	7.5		12	1	
TOTAL:					255.3	78.0	235	19	

SIGN NOTES:

1. SEE TRAFFIC SIGNAL PLANS FOR DETAILS REGARDING SIGNS MOUNTED ON MAST ARMS.

SURVEY MARKER

STATION	OFFSET	SURVEY POINT DESCRIPTION	PERM SERV MKRS T1 (EACH)
FRANK SCOTT PARKWAY EAST			
176+49	0.00'	PC	1
187+36	0.00'	PI	1
196+99	0.00'	PT	1
206+96	0.00'	PC	1
212+73	0.00'	PI	1
217+43	0.00'	PT	1
233+65	0.00'	PC	1
242+58	0.00'	PI	1
248+23	0.00'	PT	1
MAPLE STREET			
45+96	0.00'	PC	1
47+94	0.00'	PI	1
49+54	0.00'	PT	1
BOBBIE LANE			
10+12	0.00'	PC	1
10+98	0.00'	PI	1
11+81	0.00'	PT	1
FRONTAGE ROAD			
50+54	0.00'	PC	1
51+17	0.00'	PI	1
52+45	0.00'	PT	1
53+70	0.00'	PC	1
54+75	0.00'	PI	1
55+78	0.00'	PT	1
56+32	0.00'	PC	1
56+95	0.00'	PI	1
57+57	0.00'	PT	1
TOTAL			24

EROSION CONTROL

STATION	STATION	EROSION CONTR BLANKET (SY YD)	TEMP EROS CONTR SEED (NOTE 1) (POUND)	TEMP DITCH CHECKS (FOOT)	PERIMETER EROS BAR (FOOT)	INLET & PIPE PROTECTION (EACH)
FRANK SCOTT PARKWAY EAST						
160+79	161+94				175	
161+94	200+85	2,887	1,400	1,221	1,069	5
200+85	242+12	6,207	1,850	1,100	1,786	5
242+12	251+54	2,248			1,520	6
CROSS STREET						
185+00	198+51		250	160	1,273	3
MAIN STREET						
12+14	30+78		200	187	1,393	30
MAPLE STREET						
45+96	49+17		850	33	263	1
BOBBIE DRIVE						
10+43	11+22		50			
FRONTAGE ROAD						
50+63	57+57		50	66		3
ILLINOIS STATE ROUTE 158						
192+35	213+80	146	50	150	1,900	1
TOTAL		11,488	4,700	2,917	9,379	54

EROSION CONTROL NOTES:

1. THE QUANTITY FOR TEMPORARY EROSION CONTROL SEEDING ASSUMES TWO SEPARATE APPLICATIONS AT A RATE OF 100 POUNDS/ACRE PER APPLICATION. THE CONTRACTOR SHALL APPLY AS NECESSARY AND AS DIRECTED BY THE ENGINEER IN THE FIELD.

PAVEMENT MARKING

STATION	STATION	SHORT TERM PAVT MKING (FOOT)	SHRT TRM PAVT MK REM (SQ FT)	TEMP PVT MK L 4 PNT (SQ FT)	THPL PVT MK LTR & SYM (SQ FT)	THPL PVT MK LINE 4 (FOOT)	THPL PVT MK LINE 6 (FOOT)	THPL PVT MK LINE 8 (FOOT)	THPL PVT MK LINE 12 (FOOT)	THPL PVT MK LINE 24 (FOOT)	POLYRUEA PM T1 LTR-SY (SQ FT)	POLYRUEA PM T1 LN 4 (FOOT)	POLYRUEA PM T1 LN 8 (FOOT)	POLYRUEA PM T1 LN 12 (FOOT)	POLYRUEA PM T1 LN 24 (FOOT)	RAISED REFL PAVT MKR (EACH)	CURB REFLECTOR (EACH)	PAVT MRKG REM WTR BL (SQ FT)	RAISED REF MK REM (EACH)	PAINT CURB (FOOT)
FRANK SCOTT PARKWAY EAST																				
156+88	161+94										47	1,269	281	178	30	15		248		
161+94	200+85										172	21,545	335	1,128	126	179				
200+85	242+12										109	19,528	224	356	162	146				
242+12	251+54										156	5,392	672	591	24	70	41			271
CROSS STREET																				
185+00	202+40	794	264	397	281	6,335			82							106		771	29	
MAIN STREET																				
12+14	20+00	332	111	166	31	2,646			97		16	397				37		558	20	
20+00	28+01	255	85	128	31	2,315			100		31	396				39		573	20	
MAPLE STREET																				
45+97	50+00					1,581										14				
ILLINOIS STATE ROUTE 158																				
192+35	213+78	241	80	121	172	648	2,906	2,262		54						19		654		
TOTAL		1,622	540	812	515	13,525	2,906	2,262	279	54	530	48,527	1,512	2,253	342	625	41	2,804	69	271

PAVEMENT MARKING NOTES:

- SEE HIGHWAY STANDARD 780001 FOR PAVEMENT MARKING DETAILS.
- SEE HIGHWAY STANDARD 781001 FOR RAISED REFLECTIVE PAVEMENT MARKER DETAILS.
- RAISED REFLECTIVE PAVEMENT MARKER QUANTITY INCLUDES THE FOLLOWING TYPES:

286	ONE-WAY AMBER MARKERS
170	ONE-WAY CRYSTAL MARKERS
169	TWO-WAY AMBER MARKERS
625	TOTAL
- SEE PAVEMENT MARKING SHEETS FOR RRRPM DETAIL AND LAYOUT.
- QUANTITIES FOR PAINTED PAVEMENT MARKINGS ON CONCRETE SURFACES INCLUDE TWO APPLICATIONS.

F.A.U. RTE.	SECTION	COUNTY	TOTAL SHEETS	SHEET NO.
9330	95-00301-03-PV	ST. CLAIR	166	30
STA. X		TO STA. X		
FED. ROAD DIST. NO.		ILLINOIS	FED. AID PROJECT	
SCHEDULES				
CONTRACT NO.: 97372				

BY	DATE
FINAL SURVEY PLOTTED	
NOTE BOOK TEMPLATE	
AREAS CHECKED	
NO.	

BY	DATE
ORIGINAL SURVEY PLOTTED	
NOTE BOOK TEMPLATE	
AREAS CHECKED	
NO.	

SEEDING

STATION	STATION	OFFSET	SEEING CL 2 (ACRE)	NITROGEN FERT NUTR (POUND)	PHOSPHORUS FERT NUTR (POUND)	POTASSIUM FERT NUTR (POUND)	MULCH METHOD 2 (ACRE)
FRANK SCOTT PARKWAY EAST							
160+79	250+78	LT	8.00	721	721	721	8.00
160+79	250+75	RT	8.25	743	743	743	8.25
CROSS STREET							
185+00	195+75	LT	0.50	45	45	45	0.50
185+00	195+75	RT	0.75	68	68	68	0.75
MAIN STREET							
12+14	2801	LT	0.75	68	68	68	0.75
12+14	28+01	RT	0.25	23	23	23	0.25
MAPLE STREET							
45+96	49+17	LT	0.25	23	23	23	0.25
45+96	49+17	RT	0.25	23	23	23	0.25
BOBBIE ORIVE							
10+43	11+22	LT/RT	0.25	23	23	23	0.25
FRONTAGE ROAD							
50+63	57+57	LT	0.25	23	23	23	0.25
ILLINOIS STATE ROUTE 158							
192+35	213+80	RT	0.25	23	23	23	0.25
TOTAL			19.75	1,783	1,783	1,783	19.75

F.A.U. RTE.	SECTION	COUNTY	TOTAL SHEETS	SHEET NO.
9330	95-00301-03-PV	ST. CLAIR	166	31
	STA. 153+00	TO STA.	166+00	
FED. ROAD DIST. NO.	ILLINOIS	FED. AID PROJECT		
PLAN AND PROFILE				

CONTRACT NO.: 97372

EXISTING CURVE C-1
 PI STA. 150+17.94
 $\Delta = 54^{\circ}00'00''$
 $T = 835.83$
 $R = 1640.42$
 $L = 1546.06$
 $e = 5.8\%$
 ATTAINED STA. 140+66.20
 TO STA. 142+40.10
 AND STA. 158+44.10
 TO STA. 156+70.20

N/F PROGRESS EAST
 HEALTHCARE CENTER
 09-05.0-105-003
 PART OF THE N.W. 1/4
 SEC. 5, T1N, R7W
 PIN 09-05.0-102-002

SEE INTERSECTION
 DETAILS SHEET FOR
 ADDITIONAL INFORMATION
 SEE PAGE 68

SEE CROSS STREET
 PLAN VIEW FOR
 ADDITIONAL INFO
 SEE PAGE 42

2 CENTERED CURVE
 65'-350'
 13' OFFSET

N/F METRO EAST
 SERVICES INC.
 09-05.0-208-009
 DOC. A02480490
 STA. 161+94.28 FRANK SCOTT PARKWAY EAST
 STA. 196+91.35 CROSS STREET

N/F HAVENHILLS INVESTMENT
 COMP. LLC.
 09-5.0-103-001
 DOC. A0227014
 PART OF THE N.W. FRAC. 1/4
 SEC. 5, T1N, R7W
 DOC. A02014554
 PIN 09-05.0-103-001

2 CENTERED CURVE
 65'-350'
 13' OFFSET

2 CENTERED CURVE
 50'-350'
 12' OFFSET

N/F TRDS L.L.C.
 09-05.0-104-003
 DOC. A01612673

N/F TRDS, L.L.C.
 09-05.0-208-005
 DOC. A02298325

TREE MITIGATION (TYP)
 SEE SHEET 92

PAVEMENT
 REMOVAL

BY	DATE

BY	DATE

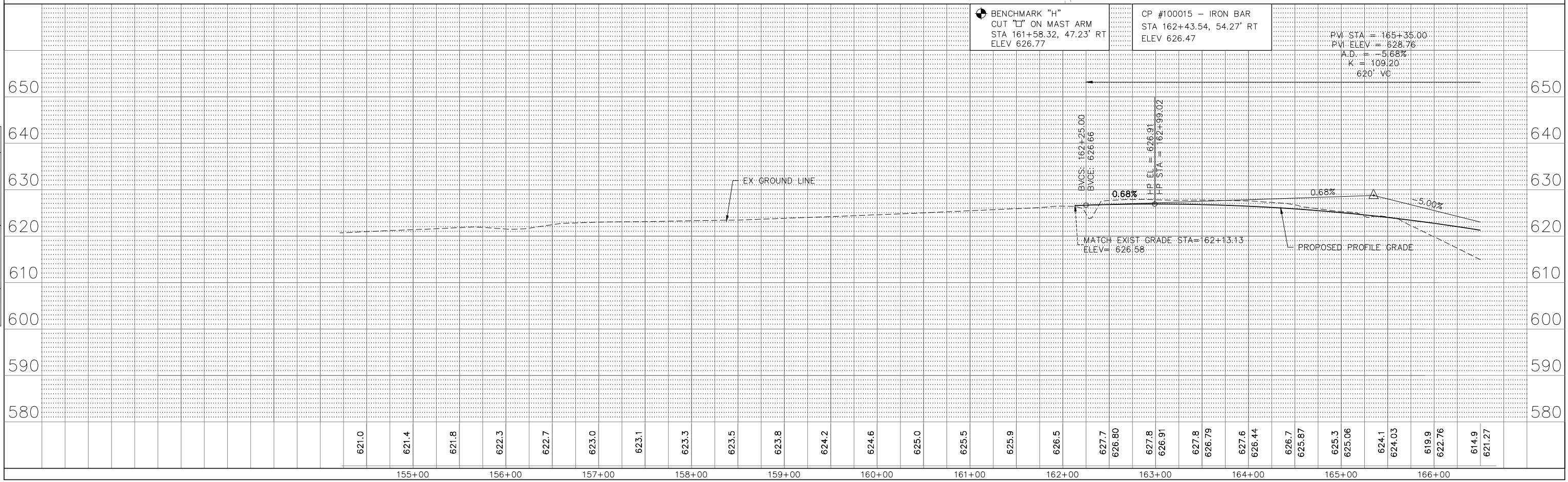
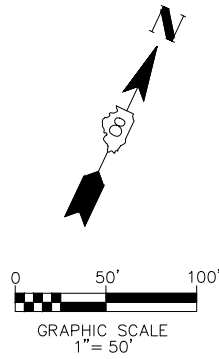

FRANK SCOTT PARKWAY EAST

F.A.U. RTE.	SECTION	COUNTY	TOTAL SHEETS	SHEET NO.
9330	95-00301-03-PV	ST. CLAIR	166	32
STA.	166+00	TO STA.	179+00	
FED. ROAD DIST. NO.	ILLINOIS	FED. AID PROJECT		
PLAN AND PROFILE				

CONTRACT NO.: 97372

BY	DATE

NO.	AREAS CHECKED

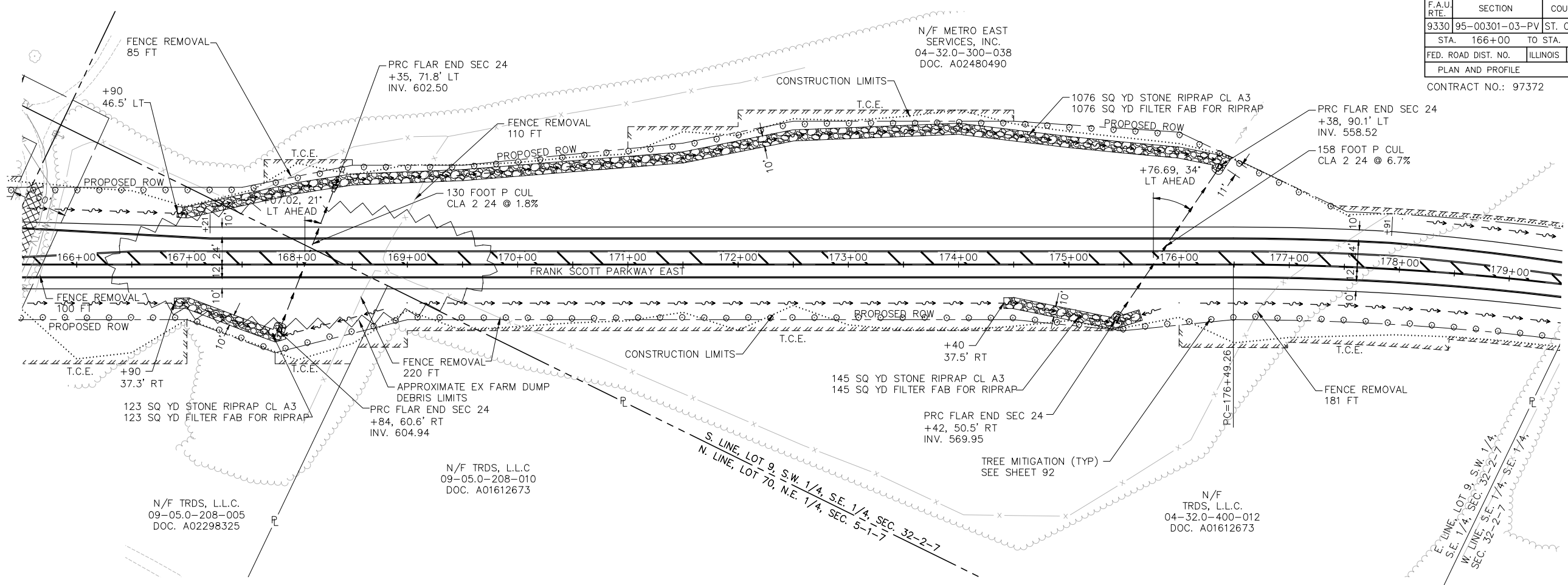
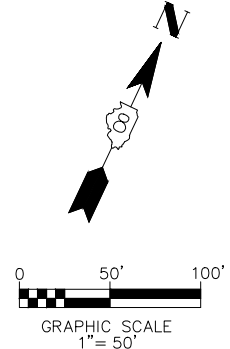

BY	DATE

NO.	AREAS CHECKED

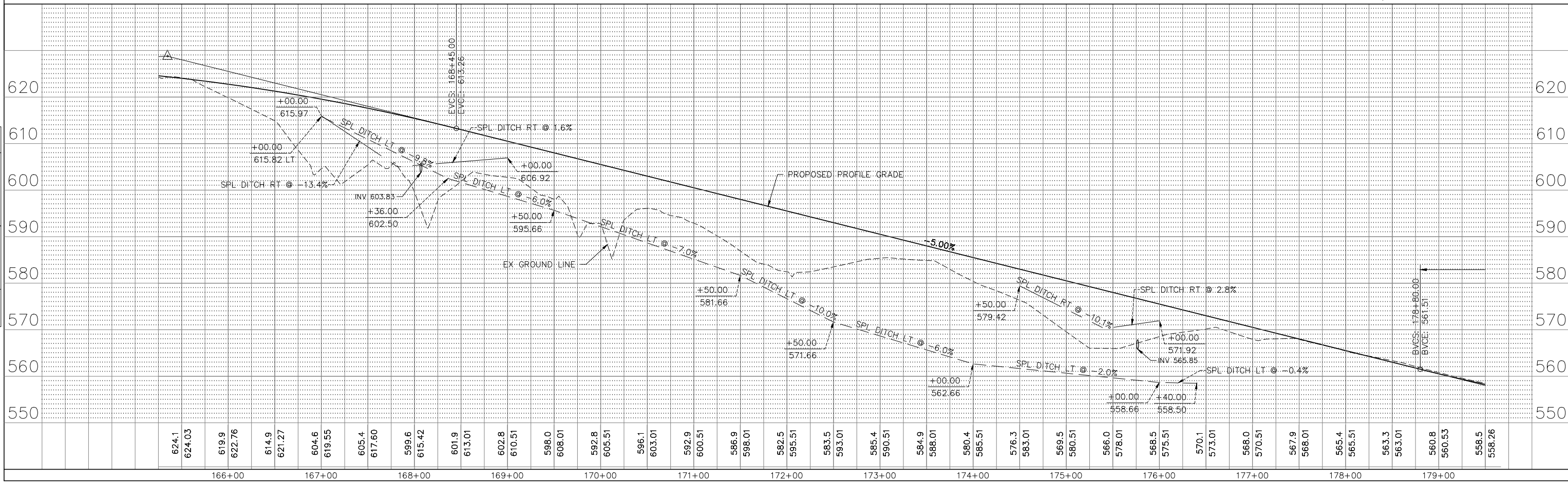

FRANK SCOTT PARKWAY EAST

F.A.U. RTE.	SECTION	COUNTY	TOTAL SHEETS	SHEET NO.
9330	95-00301-03-PV	ST. CLAIR	166	33
STA. 179+00 TO STA. 192+00				
FED. ROAD DIST. NO.		ILLINOIS	FED. AID PROJECT	
PLAN AND PROFILE				

CONTRACT NO.: 97372

N/F DUNN, JAMES E. &
WUEBBELS, ELIZABETH
A. TRUSTEES
04-32.0-400-015
DOC. A02700227

N/F DUNN, JAMES E. &
WUEBBELS, ELIZABETH
A. TRUSTEES
04-32.0-400-016
DOC. A02700227

PROPOSED CURVE C-2
PI STA. 187+36.04
 $\Delta = 46^{\circ}59'26''$
T = 1086.78'
R = 2500.00'
L = 2050.35'
e = 2.9%
PC = 176+49.26
PT = 196+99.61
ATTAINED STA. 175+64.26
TO STA. 176+70.26
AND STA. 196+78.61
TO STA. 197+84.61

BY	DATE

BY	DATE

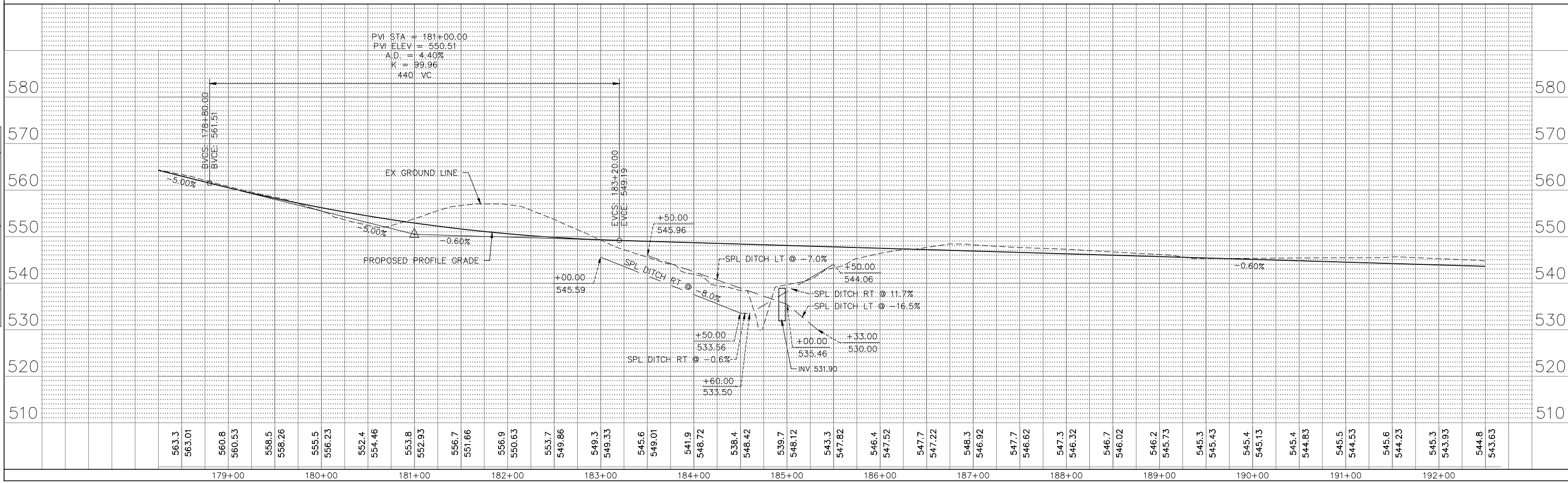
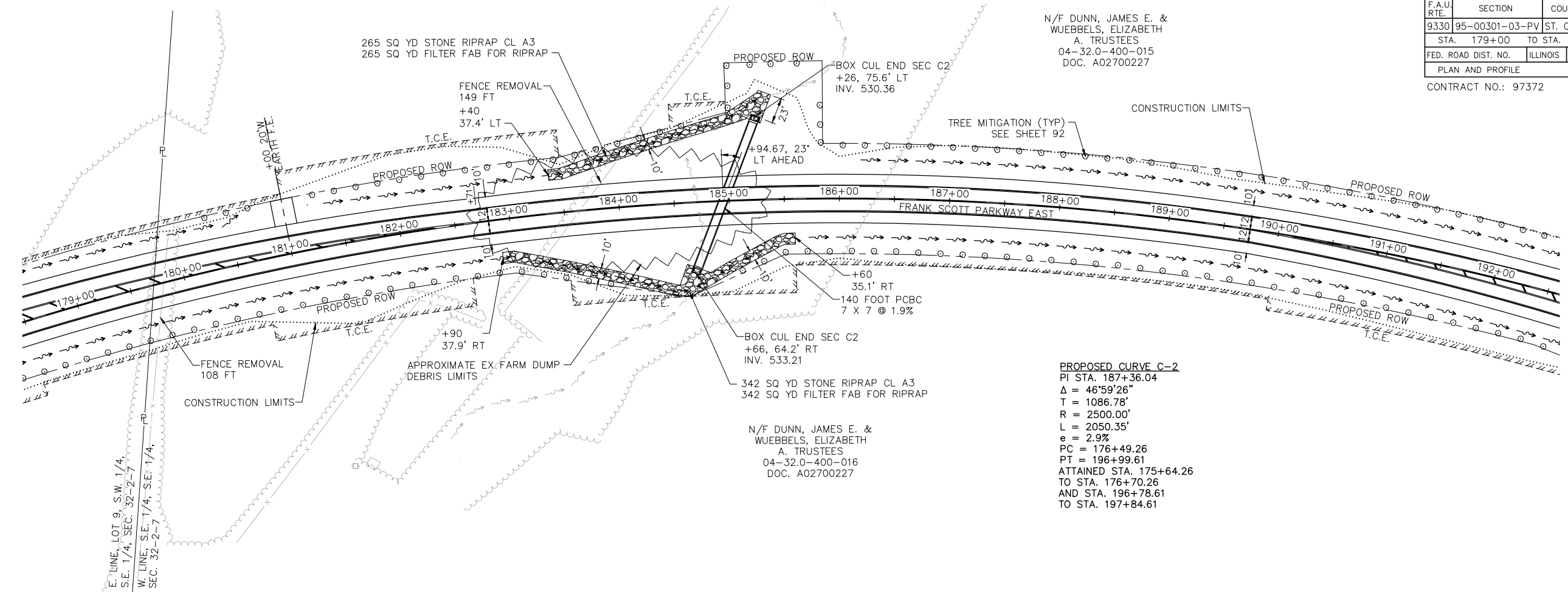
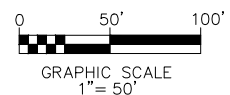

F.A.U. RTE.	SECTION	COUNTY	TOTAL SHEETS	SHEET NO.
9330	95-00301-03-PV	ST. CLAIR	166	34
	STA. 192+00	TO STA. 205+00		
FED. ROAD DIST. NO.	ILLINOIS	FED. AID PROJECT		
PLAN AND PROFILE				

CONTRACT NO.: 97372

BY	DATE

BY	DATE

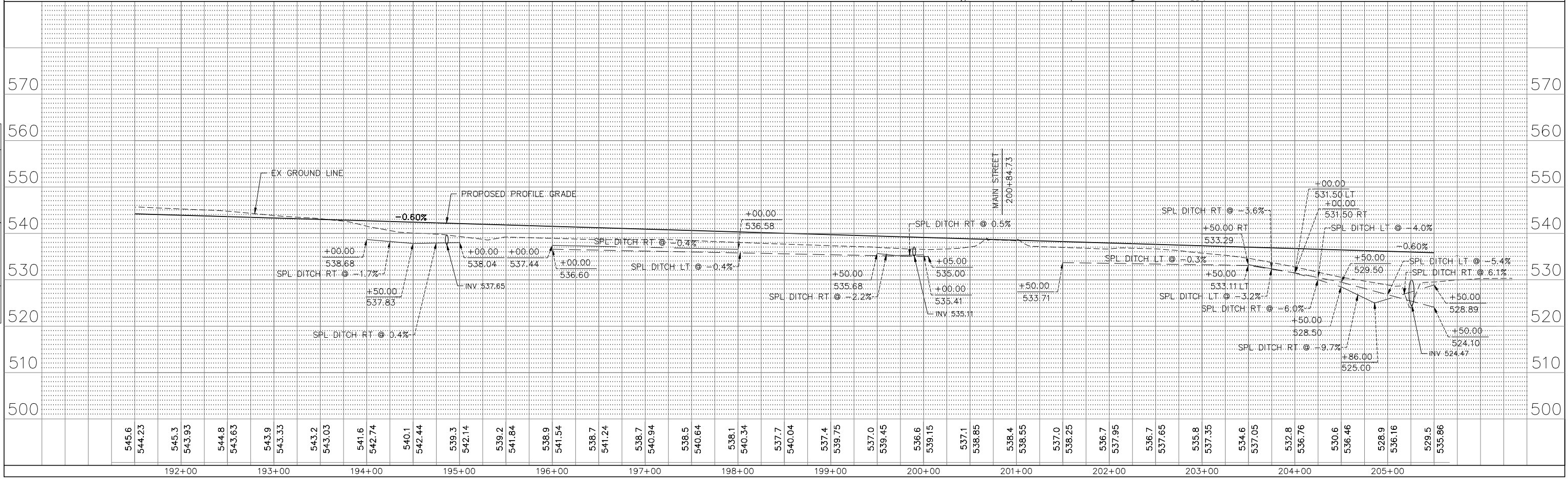
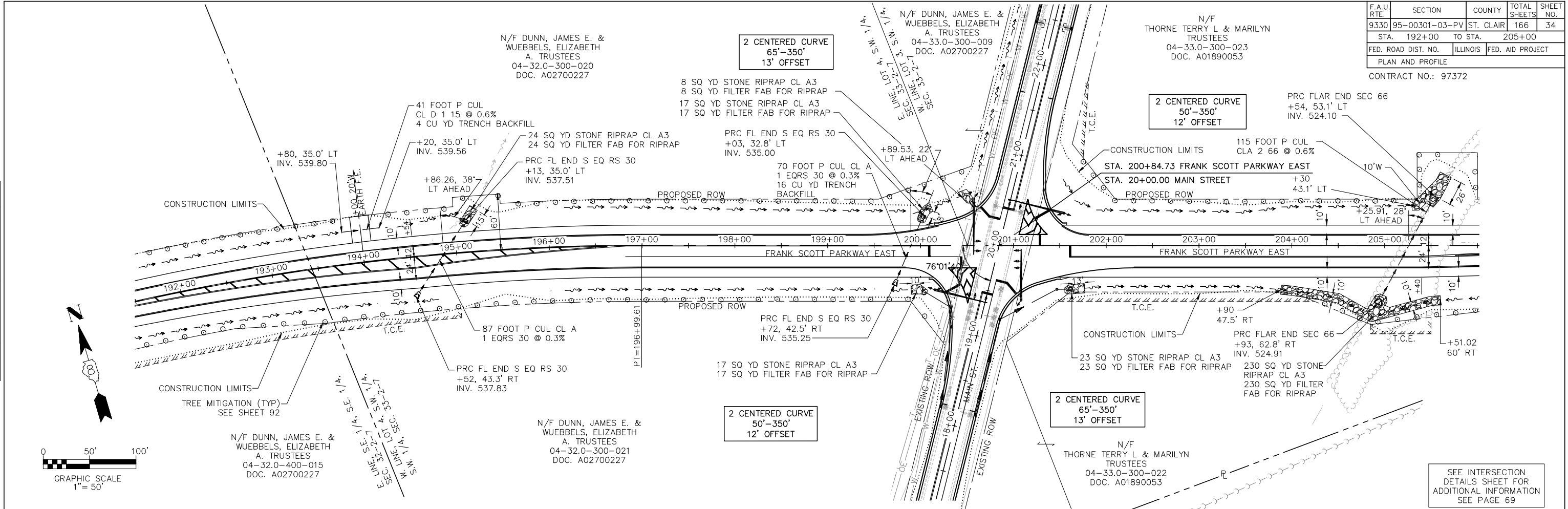

F.A.U. RTE.	SECTION	COUNTY	TOTAL SHEETS	SHEET NO.
9330	95-00301-03-PV	ST. CLAIR	166	35
	STA. 205+00	TO STA. 218+00		
FED. ROAD DIST. NO.	ILLINOIS	FED. AID PROJECT		
PLAN AND PROFILE				
CONTRACT NO.: 97372				

BY	DATE

BY	DATE

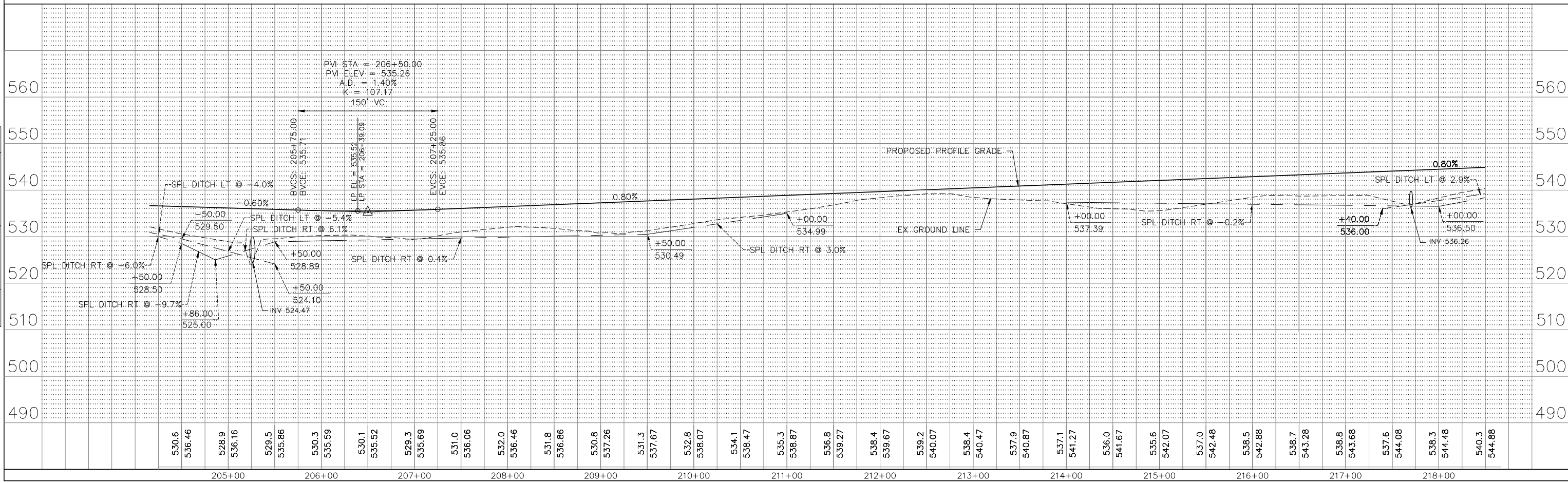
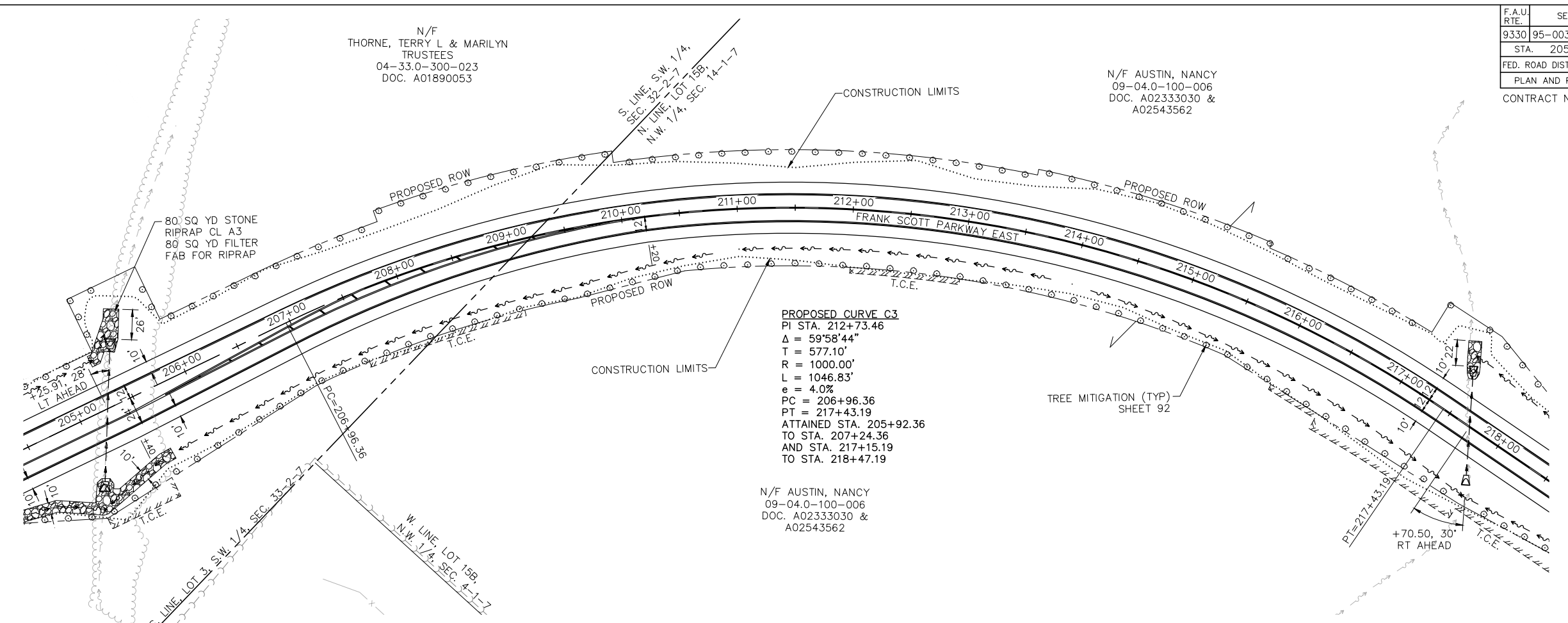
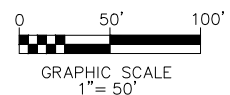

F.A.U. RTE.	SECTION	COUNTY	TOTAL SHEETS	SHEET NO.
9330	95-00301-03-PV	ST. CLAIR	166	36
STA. 218+00	TO STA. 231+00			
FED. ROAD DIST. NO.	ILLINOIS	FED. AID PROJECT		
PLAN AND PROFILE				

CONTRACT NO.: 97372

N/F AUSTIN, NANCY
09-04.0-100-006
DOC. A02333030 &
A02543562

N/F AUSTIN, NANCY
09-04.0-100-006
DOC. A02333030 &
A02543562

42 SQ YD STONE RIPRAP CL A3
42 SQ YD FILTER FAB FOR RIPRAP
PRC FLAR END SEC 48
+44, 118.2' LT
INV. 523.50

39 SQ YD STONE RIPRAP CL A3
39 SQ YD FILTER FAB FOR RIPRAP

PRC FLAR END SEC 42
+44, 44.9' LT
INV. 536.04

86 FOOT P CUL
CLA 2 42 @ 0.4%

PRC FLAR END SEC 42
+96, 43.2' RT
INV. 536.46

+05.98, 49°29'9"
LT AHEAD

280 FOOT P CUL
CLA 4 48 @ 2.5%

PRC FLAR END SEC 48
+18.96, 74.4' RT
INV. 531.00

PT=217+43.19
+70.50, 30'
RT AHEAD

+35.32, 19'
LT AHEAD

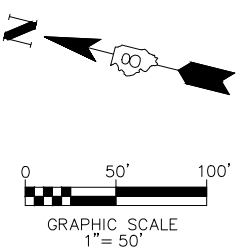

BY	DATE

BY	DATE

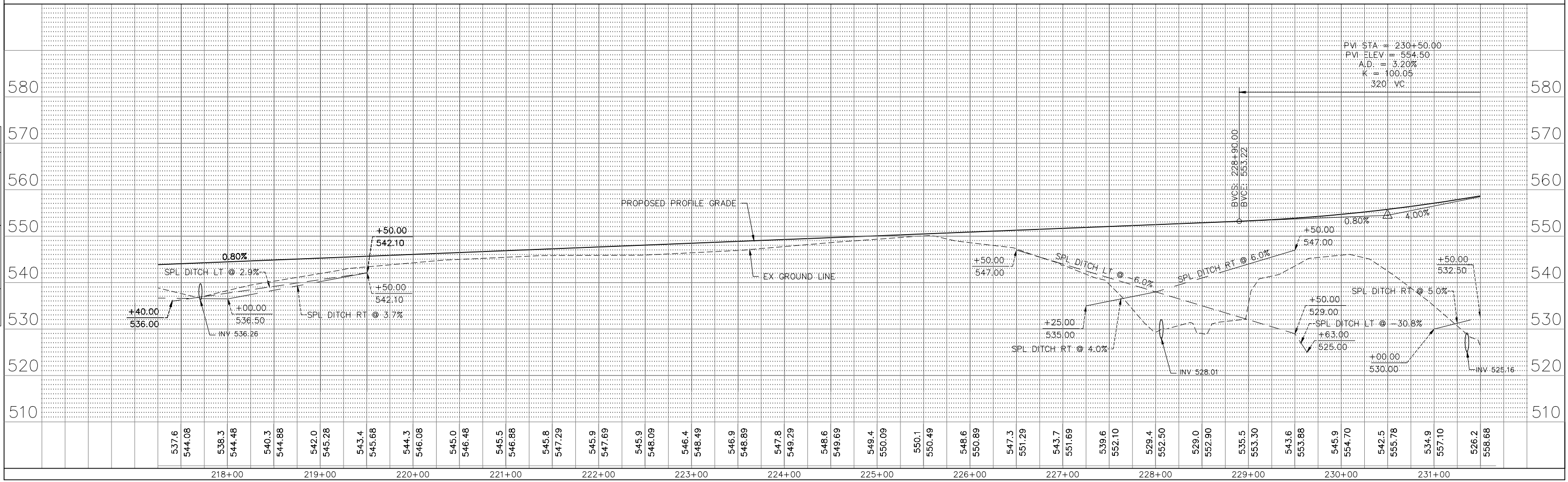

F.A.U. RTE.	SECTION	COUNTY	TOTAL SHEETS	SHEET NO.
9330	95-00301-03-PV	ST. CLAIR	166	37
STA. 231+00 TO STA. 243+00				
FED. ROAD DIST. NO.		ILLINOIS	FED. AID PROJECT	
PLAN AND PROFILE				

CONTRACT NO.: 97372

N/F AUSTIN, NANCY
09-04.0-100-006
DOC. A02333030 &
A02543562

PT LOT 15B
P.B. "C", PG. 367
PIN 09-04.0-100-006

SEE INTERSECTION
DETAILS SHEET FOR
ADDITIONAL INFO
SEE PAGE 70

N/F BOSSLER, ARNOLD
TRUSTEE
TRUST: BOSSLER FAMILY
TRUST
09-04.0-100-019
DOC. A02412412

PROPOSED CURVE C7
PI STA. 50+94.04
 $\Delta = 86^{\circ}10'36"$
R = 42.00'
T = 39.29'
L = 63.17'
E = 15.51'
e = NONE
PC = 50+54.75
PC = 51+17.92

PROPOSED CURVE C4
PI STA. 242+58.31
 $\Delta = 83^{\circ}29'57"$
R = 1,000.00'
T = 892.52'
L = 1,457.33'
E = 340.37'
e = 4.0%
PC = 233+65.79
PT = 248+23.12
ATTAINED STA. 232+61.79
TO STA. 233+93.79
AND STA. 247+95.12
TO STA. 249+27.12

PROPOSED CURVE C6
PI STA. 10+98.61
 $\Delta = 28^{\circ}35'02"$
R = 340.00'
T = 86.61'
L = 169.62'
E = 10.86'
e = NONE
PC = 10+12.00
PT = 11+81.62

BY	DATE

BY	DATE

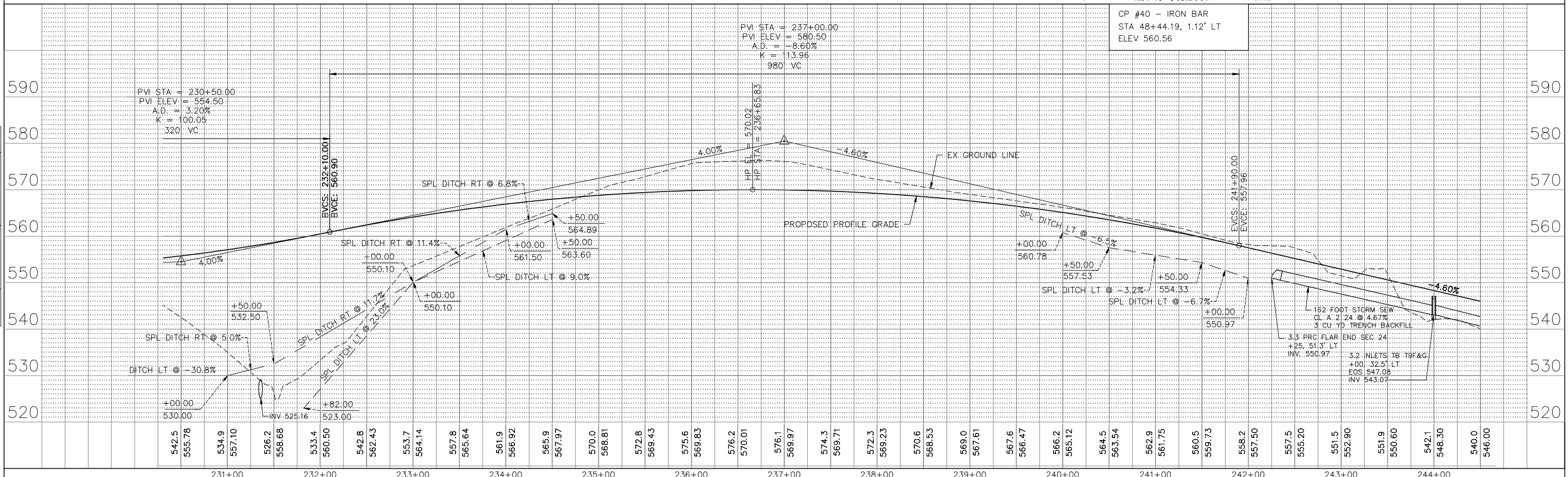
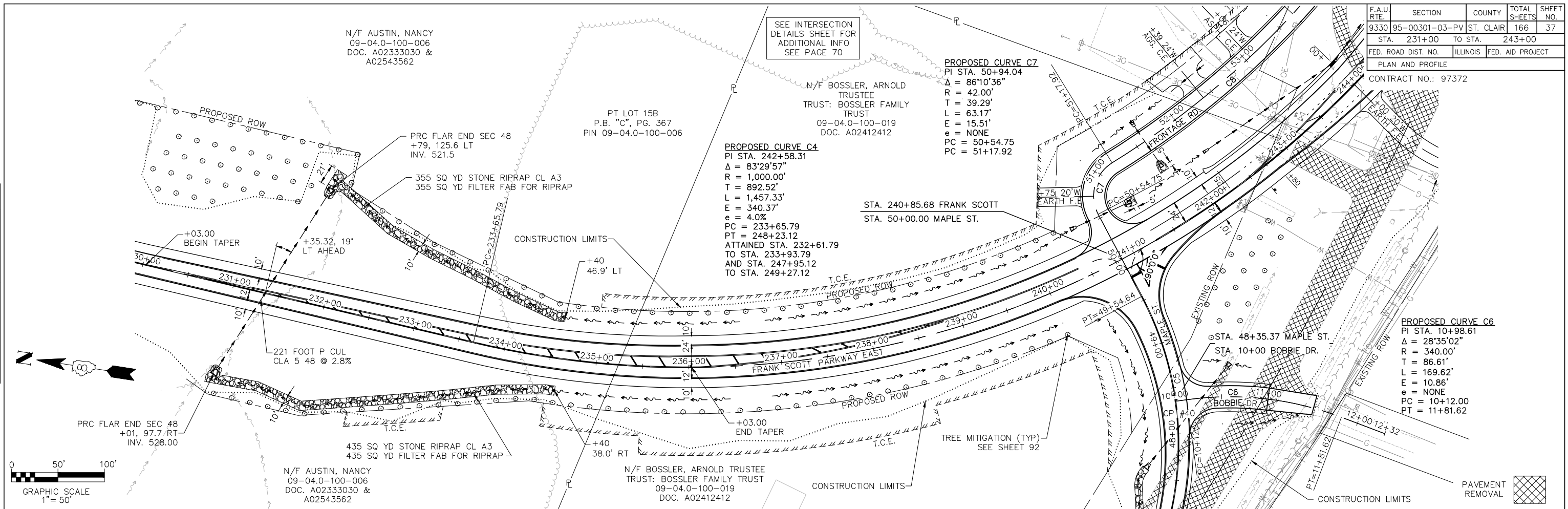

F.A.U. RTE.	SECTION	COUNTY	TOTAL SHEETS	SHEET NO.
9330	95-00301-03-PV	ST. CLAIR	166	38
	STA. 243+00	TO STA.	252+00	
FED. ROAD DIST. NO.		ILLINOIS	FED. AID PROJECT	
PLAN AND PROFILE				

CONTRACT NO.: 97372

FRONTAGE ROAD CURVE DATA

PROPOSED CURVE C8
 PI STA. 52+45.15
 $\Delta = 15^{\circ}26'57''$
 $R = 938.00'$
 $T = 127.23'$
 $L = 252.92'$
 $E = 8.59'$
 $e = \text{NONE}$
 $PC = 51+17.92$
 $PT = 53+70.84$

PROPOSED CURVE C9
 PI STA. 54+75.86
 $\Delta = 19^{\circ}51'26''$
 $R = 600.00'$
 $T = 105.02'$
 $L = 207.94'$
 $E = 9.12'$
 $e = \text{NONE}$
 $PC = 53+70.84$
 $PT = 55+78.78$

PROPOSED CURVE C10
 PI STA. 56+95.29
 $\Delta = 17^{\circ}53'46''$
 $R = 400.00'$
 $T = 62.98'$
 $L = 124.94'$
 $E = 4.93'$
 $e = \text{NONE}$
 $PC = 56+32.31$
 $PT = 57+57.25$

SEE INTERSECTION
 DETAILS SHEET FOR
 ADDITIONAL INFORMATION
 SEE PAGES 71 AND 72

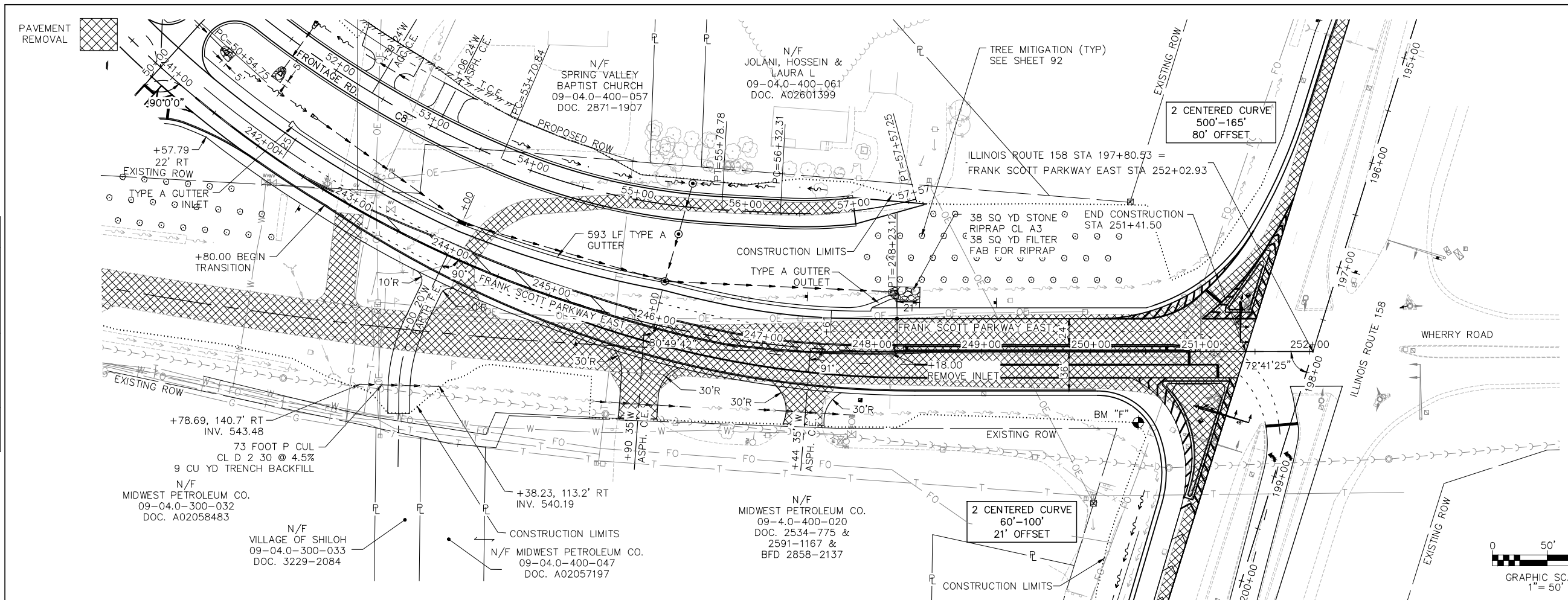

BY	DATE

BY	DATE

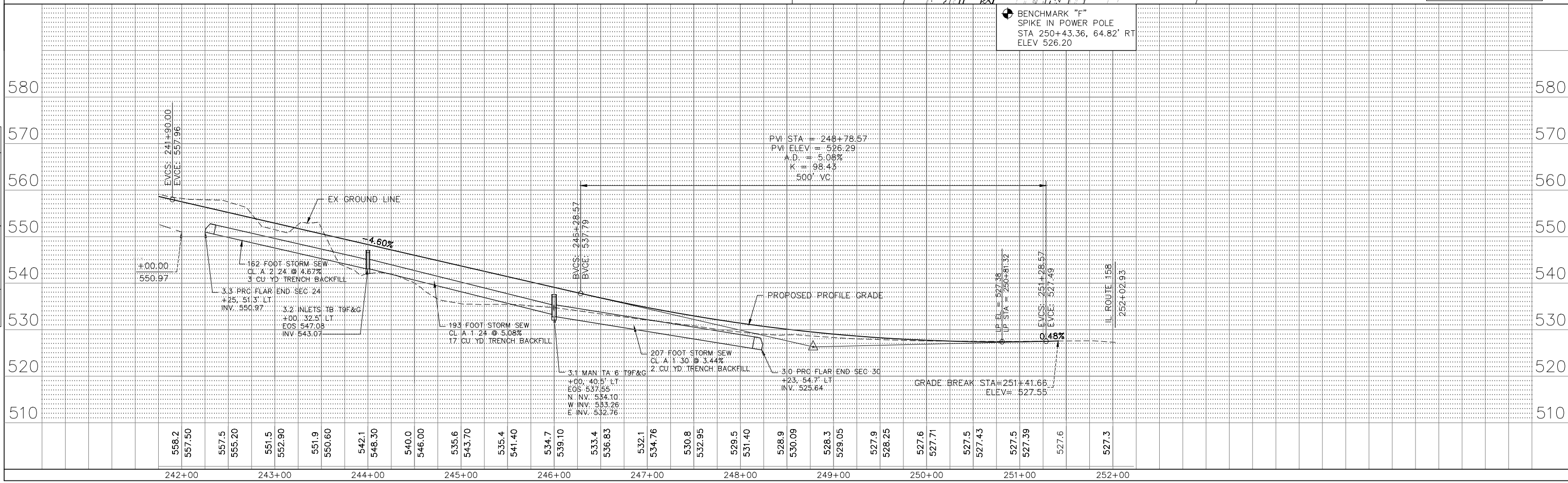

F.A.U. RTE.	SECTION	COUNTY	TOTAL SHEETS	SHEET NO.
9330	95-00301-03-PV	ST. CLAIR	166	39
STA. 187+00	TO STA. 200+00			
FED. ROAD DIST. NO.	ILLINOIS	FED. AID PROJECT		
PLAN AND PROFILE CROSS STREET				

CONTRACT NO.: 97372

N/F TRDS, L.L.C.
09-05.0-104-003
DOC. A01612673

+09.15
22' RT

+89.54
18' LT

+51.35
18' RT

+21.29
24' RT

EXISTING CURVE C5
PI STA. 205+22.5

$\Delta = 44^\circ 17' 45''$
T = 777.47
R = 1910.08
L = 1476.70
e = 3.3%

PC = 197+44.90
PT = 212+21.60
ATTAINED STA. 196+55.40
TO STA. 198+34.40
AND STA. 211+32.10
TO STA. 213+11.10

N/F HAVENHILLS INVESTMENT COMP, LLC.
09-05.0-103-001
DOC. A02270149

N/F METRO EAST SERVICES, INC.
09-05.0-208-009
DOC. A02480490

STA. 161+94.28 FRANK SCOTT PARKWAY EAST
STA. 196+91.35 CROSS STREET

T.C.E.
PARCEL-A

+83.39.0' LT
INV. 616.53

95' R

309 LF TYPE A GUTTER

TB-6.24 CURB & GUTTER

CONSTRUCTION LIMITS

+96.16
38' LT

EXISTING ROW

PROPOSED ROW

FRANK SCOTT PARKWAY EAST

PROPOSED ROW

EXISTING ROW

EXISTING ROW

EXISTING ROW

EXISTING ROW

EXISTING ROW

EXISTING ROW

EXISTING ROW

EXISTING ROW

EXISTING ROW

SEE INTERSECTION DETAILS SHEET FOR ADDITIONAL INFORMATION SEE PAGE 73

N/F METRO EAST SERVICES, INC.
04-32.0-300-038
DOC. A02480490

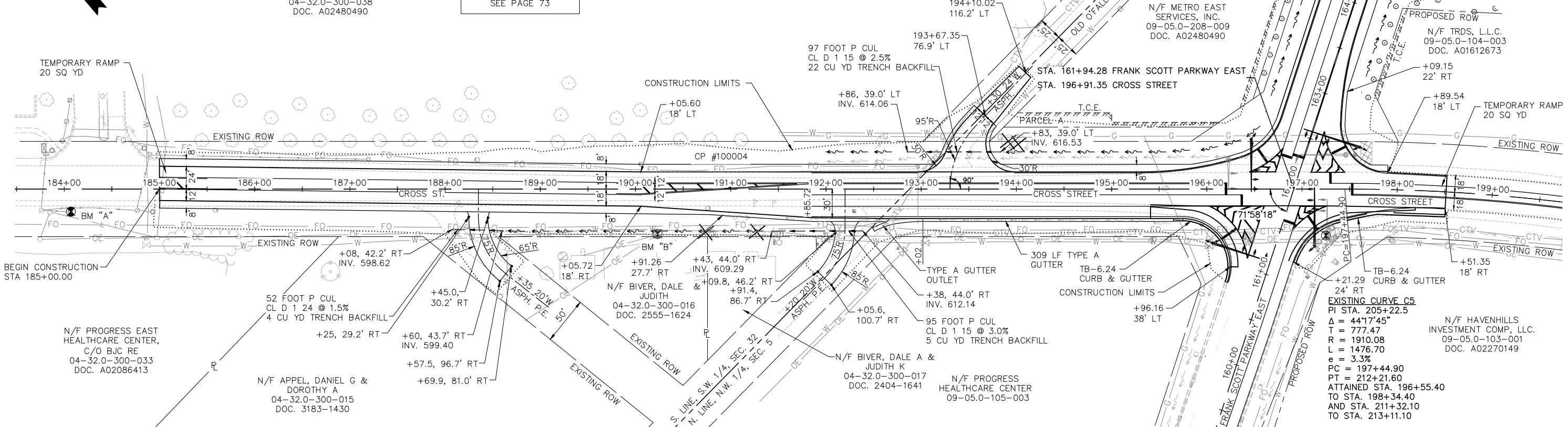
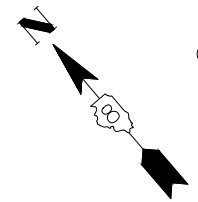
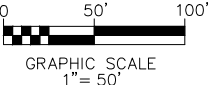

BY	DATE

BY	DATE

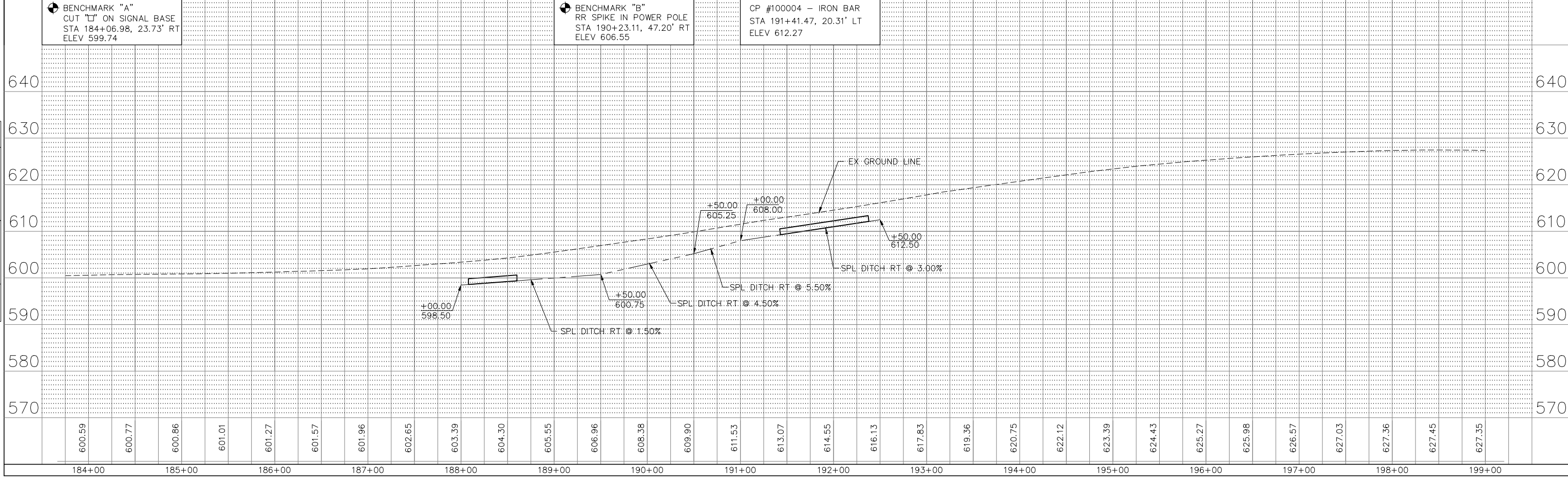

⊙ BENCHMARK "A"
CUT "I" ON SIGNAL BASE
STA 184+06.98, 23.73' RT
ELEV 599.74

⊙ BENCHMARK "B"
RR SPIKE IN POWER POLE
STA 190+23.11, 47.20' RT
ELEV 606.55

CP #100004 - IRON BAR
STA 191+41.47, 20.31' LT
ELEV 612.27

184+00 185+00 186+00 187+00 188+00 189+00 190+00 191+00 192+00 193+00 194+00 195+00 196+00 197+00 198+00 199+00

CROSS STREET

F.A.U. RTE.	SECTION	COUNTY	TOTAL SHEETS	SHEET NO.
9330	95-00301-03-PV	ST. CLAIR	166	40
STA.	200+00	TO STA.	207+00	
FED. ROAD DIST. NO.	ILLINOIS	FED. AID PROJECT		
PLAN AND PROFILE CROSS STREET				
CONTRACT NO.: 97372				

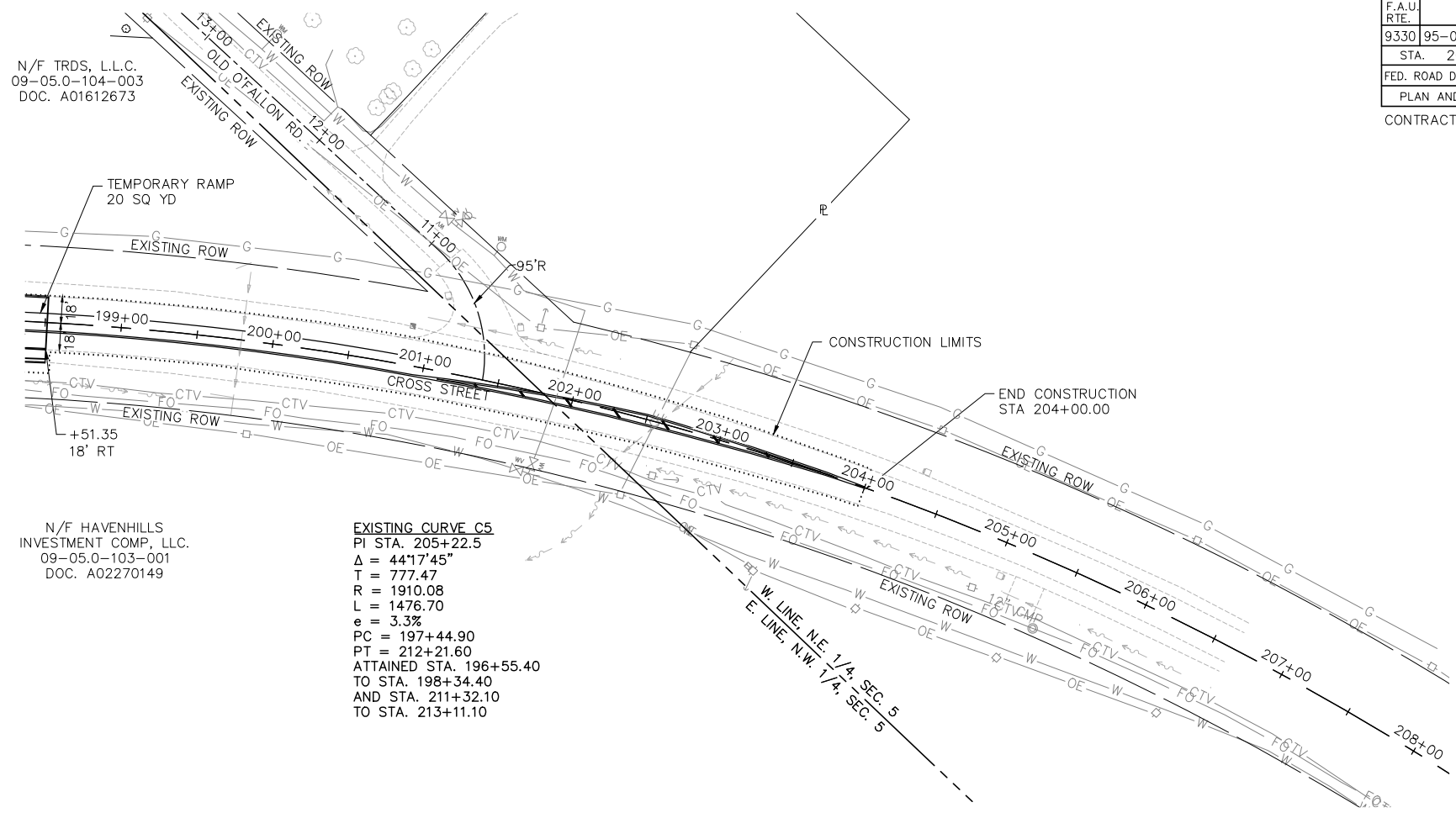

N/F TRDS, L.L.C.
09-05.0-104-003
DOC. A01612673

N/F HAVENHILLS INVESTMENT COMP, LLC.
09-05.0-103-001
DOC. A02270149

EXISTING CURVE C5
 PI STA. 205+22.5
 $\Delta = 44^{\circ}17'45''$
 T = 777.47
 R = 1910.08
 L = 1476.70
 e = 3.3%
 PC = 197+44.90
 PT = 212+21.60
 ATTAINED STA. 196+55.40
 TO STA. 198+34.40
 AND STA. 211+32.10
 TO STA. 213+11.10

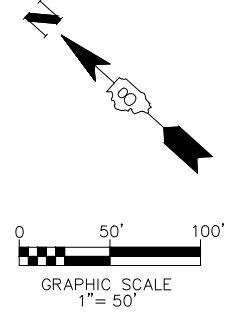

BY	DATE

BY	DATE

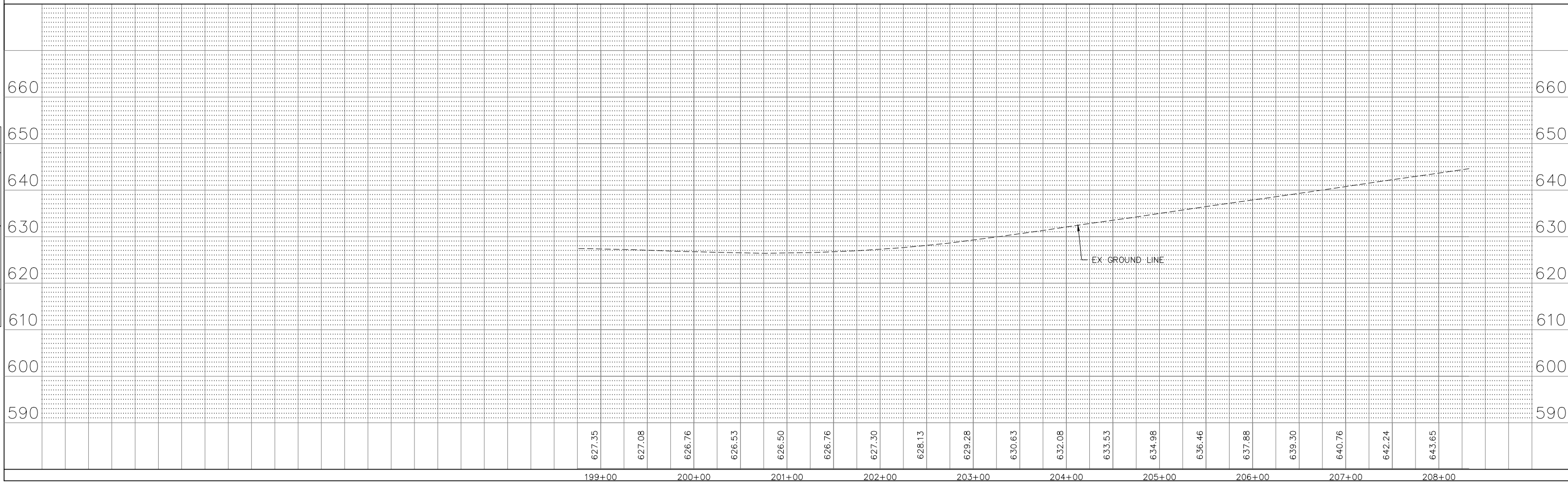

CROSS STREET

F.A.U. RTE.	SECTION	COUNTY	TOTAL SHEETS	SHEET NO.
9330	95-00301-03-PV	ST. CLAIR	166	41
STA. 9+00	TO STA. 22+00			
FED. ROAD DIST. NO.	ILLINOIS	FED. AID PROJECT		
PLAN AND PROFILE MAIN STREET				
CONTRACT NO.: 97372				

N/F LAKE SUZANNE MHP LLC,
C/O SMITH MANAGEMENT LLC.
09-04.0-100-010
DOC. A02732502

NOTE: ALL EXISTING STORM SEWER ALONG MAIN STREET TO BE FILLED OR AMERICAN WATER CO.
09-04.0-100-011
DOC. A02651772

N/F DUNN, JAMES, E & WUEBBELS, ELIZABETH A TRUSTEES
04-33.0-300-021
DOC. A02700227

N/F VALLEY VIEW ESTATES INVESTORS, LLC.
09-04.0-100-021
DOC. A02743065

N/F VALLEY VIEW ESTATES INVESTORS, LLC.
09-04.0-100-020
DOC. A02743066

BY	DATE

BY	DATE

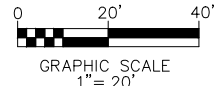
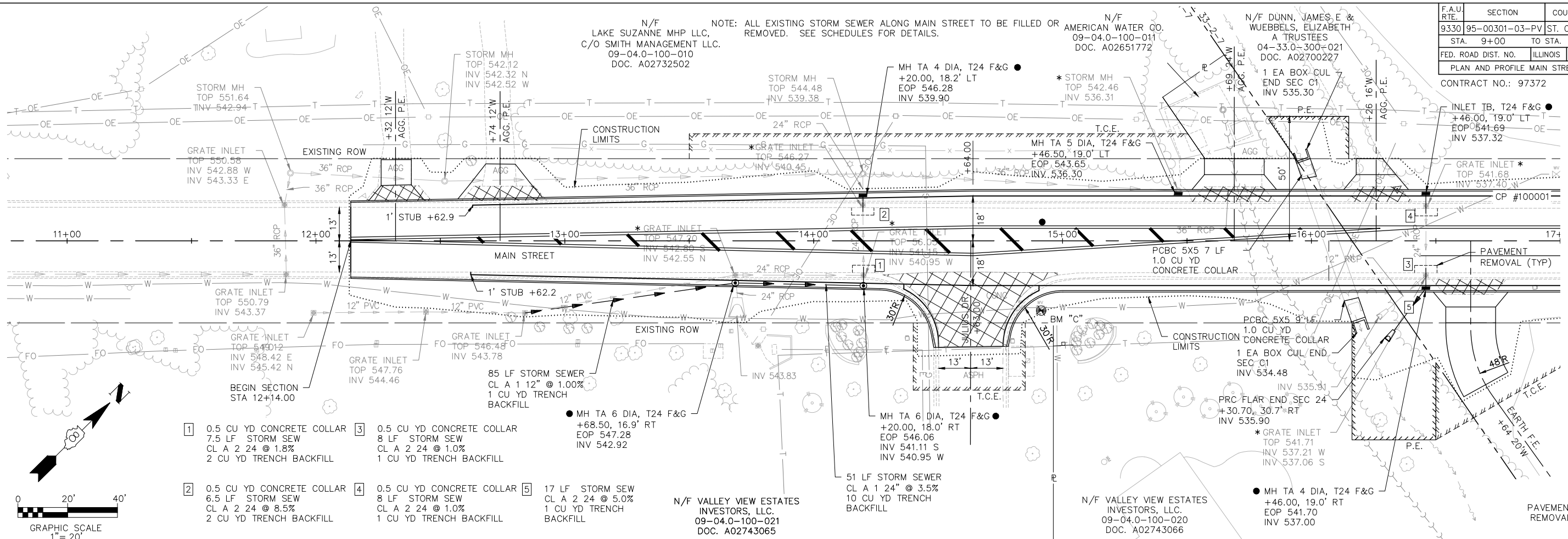

- 1 0.5 CU YD CONCRETE COLLAR
7.5 LF STORM SEW
CL A 2 24 @ 1.8%
2 CU YD TRENCH BACKFILL
- 2 0.5 CU YD CONCRETE COLLAR
6.5 LF STORM SEW
CL A 2 24 @ 8.5%
2 CU YD TRENCH BACKFILL
- 3 0.5 CU YD CONCRETE COLLAR
8 LF STORM SEW
CL A 2 24 @ 1.0%
1 CU YD TRENCH BACKFILL
- 4 0.5 CU YD CONCRETE COLLAR
8 LF STORM SEW
CL A 2 24 @ 1.0%
1 CU YD TRENCH BACKFILL
- 5 17 LF STORM SEWER
CL A 2 24 @ 5.0%
1 CU YD TRENCH BACKFILL

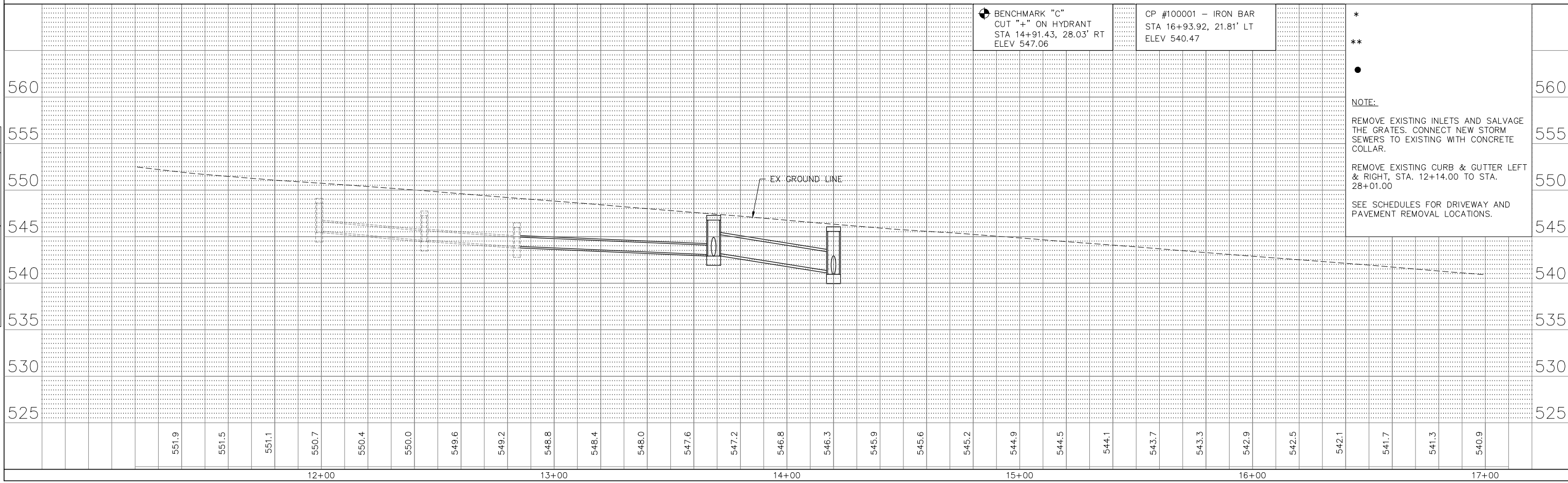

ELEVATION	STATION	DESCRIPTION
560	14+91.43	BENCHMARK "C" CUT "+" ON HYDRANT STA 14+91.43, 28.03' RT ELEV 547.06
540.47	16+93.92	CP #100001 - IRON BAR STA 16+93.92, 21.81' LT ELEV 540.47

NOTE:
 * REMOVE EXISTING INLETS AND SALVAGE THE GRATES. CONNECT NEW STORM SEWERS TO EXISTING WITH CONCRETE COLLAR.
 ** REMOVE EXISTING CURB & GUTTER LEFT & RIGHT, STA. 12+14.00 TO STA. 28+01.00
 SEE SCHEDULES FOR DRIVEWAY AND PAVEMENT REMOVAL LOCATIONS.

MAIN STREET

F.A.U. RTE.	SECTION	COUNTY	TOTAL SHEETS	SHEET NO.
9330	95-00301-03-PV	ST. CLAIR	166	42
STA. 9+00	TO STA. 22+00			
FED. ROAD DIST. NO.	ILLINOIS	FED. AID PROJECT		
PLAN AND PROFILE MAIN STREET				
CONTRACT NO.: 97372				

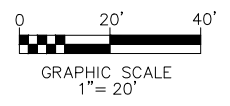
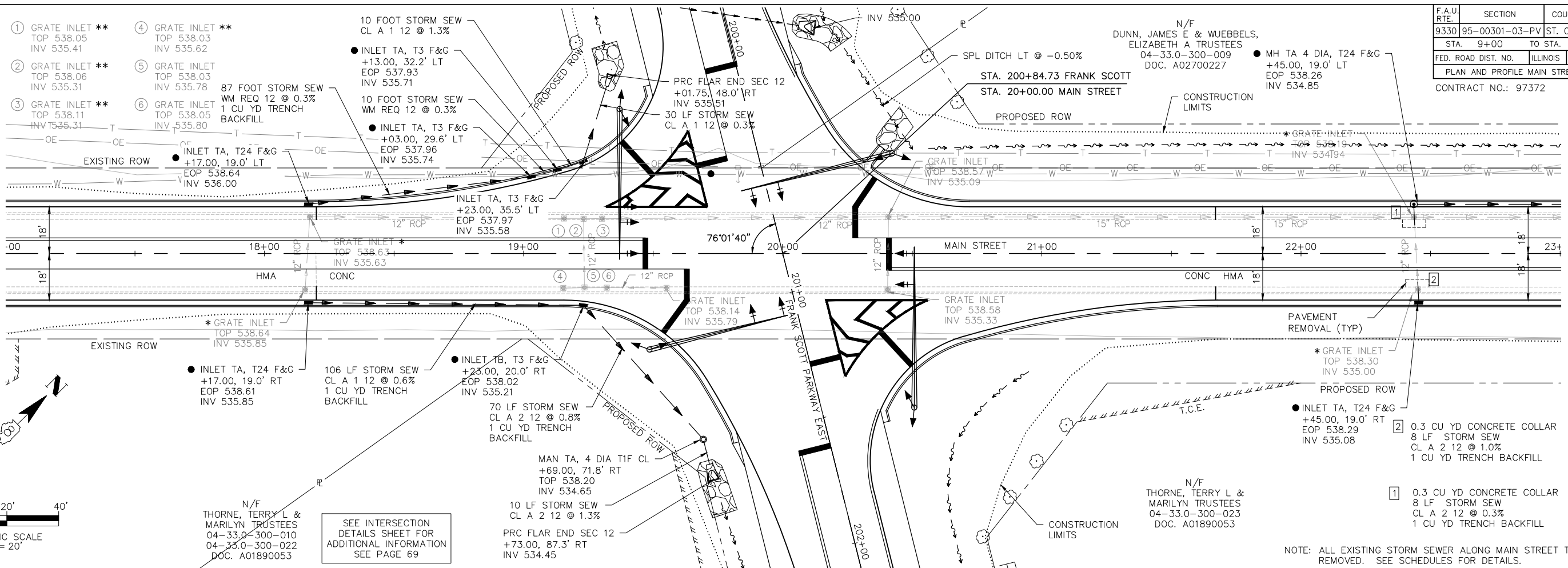

BY	DATE

BY	DATE

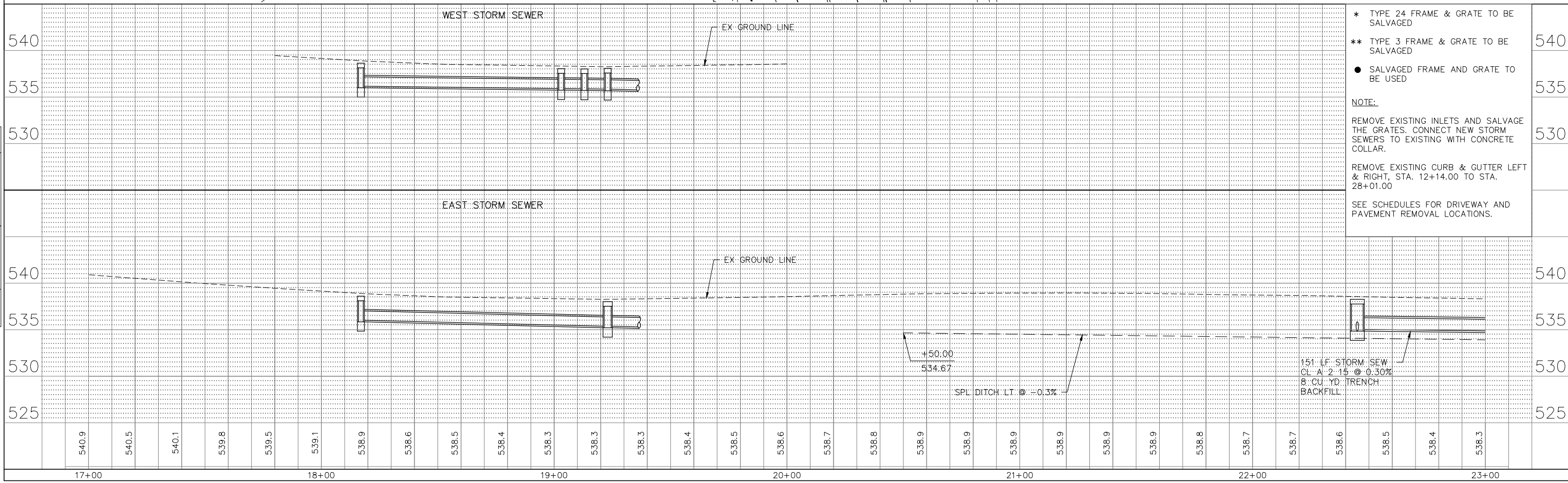

- * TYPE 24 FRAME & GRATE TO BE SALVAGED
 - ** TYPE 3 FRAME & GRATE TO BE SALVAGED
 - SALVAGED FRAME AND GRATE TO BE USED
- NOTE:
REMOVE EXISTING INLETS AND SALVAGE THE GRATES. CONNECT NEW STORM SEWERS TO EXISTING WITH CONCRETE COLLAR.
REMOVE EXISTING CURB & GUTTER LEFT & RIGHT, STA. 12+14.00 TO STA. 28+01.00
SEE SCHEDULES FOR DRIVEWAY AND PAVEMENT REMOVAL LOCATIONS.

MAIN STREET

F.A.U. RTE.	SECTION	COUNTY	TOTAL SHEETS	SHEET NO.
9330	95-00301-03-PV	ST. CLAIR	166	43
STA. 9+00	TO STA. 22+00			
FED. ROAD DIST. NO.	ILLINOIS	FED. AID PROJECT		
PLAN AND PROFILE MAIN STREET				
CONTRACT NO.: 97372				

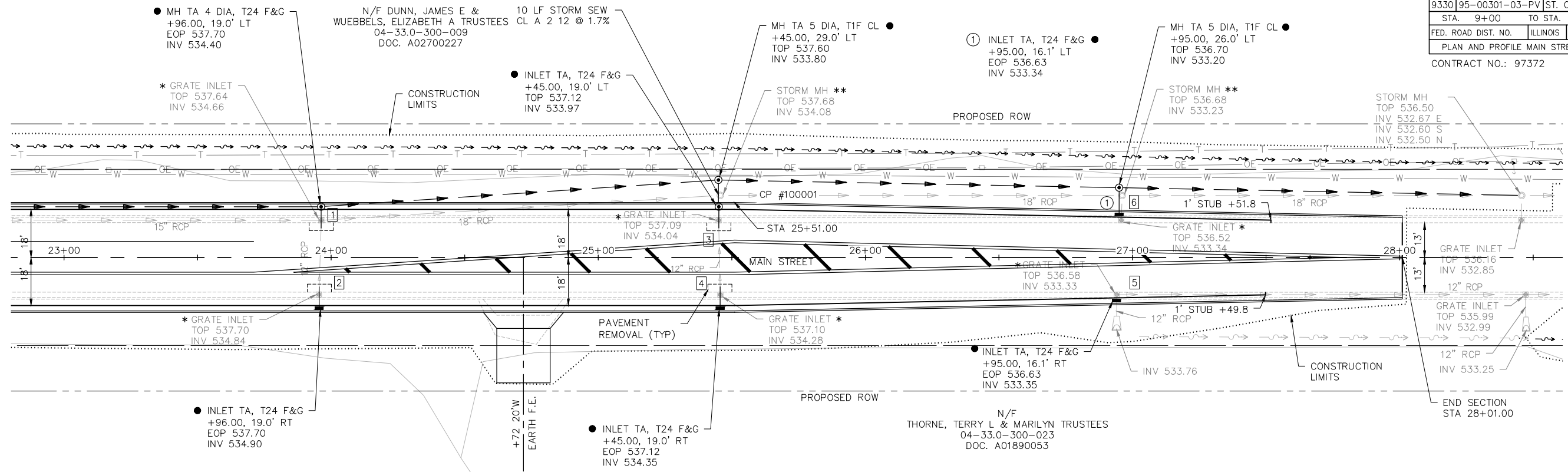

- 1 0.3 CU YD CONCRETE COLLAR
8 LF STORM SEW
CL A 2 12 @ 0.6%
1 CU YD TRENCH BACKFILL
- 2 0.3 CU YD CONCRETE COLLAR
8 LF STORM SEW
CL A 2 12 @ 0.6%
1 CU YD TRENCH BACKFILL
- 3 0.3 CU YD CONCRETE COLLAR
8 LF STORM SEW
CL A 2 12 @ 0.9%
1 CU YD TRENCH BACKFILL
- 4 0.3 CU YD CONCRETE COLLAR
8 LF STORM SEW
CL A 2 12 @ 0.9%
1 CU YD TRENCH BACKFILL
- 5 0.3 CU YD CONCRETE COLLAR
3 LF STORM SEW
CL A 2 12 @ 0.2%
1 CU YD TRENCH BACKFILL
- 6 10 LF STORM SEW
CL A 2 12 @ 1.4%
2 CU YD TRENCH BACKFILL

NOTE: ALL EXISTING STORM SEWER ALONG MAIN STREET TO BE FILLED OR REMOVED. SEE SCHEDULES FOR DETAILS.

- * TYPE 24 FRAME & GRATE TO BE SALVAGED
- ** TYPE 3 FRAME & GRATE TO BE SALVAGED
- SALVAGED FRAME AND GRATE TO BE USED

NOTE:
REMOVE EXISTING INLETS AND SALVAGE THE GRATES. CONNECT NEW STORM SEWERS TO EXISTING WITH CONCRETE COLLAR.
REMOVE EXISTING CURB & GUTTER LEFT & RIGHT, STA. 12+14.00 TO STA. 28+01.00
SEE SCHEDULES FOR DRIVEWAY AND PAVEMENT REMOVAL LOCATIONS.

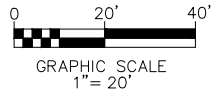

BY	DATE

BY	DATE

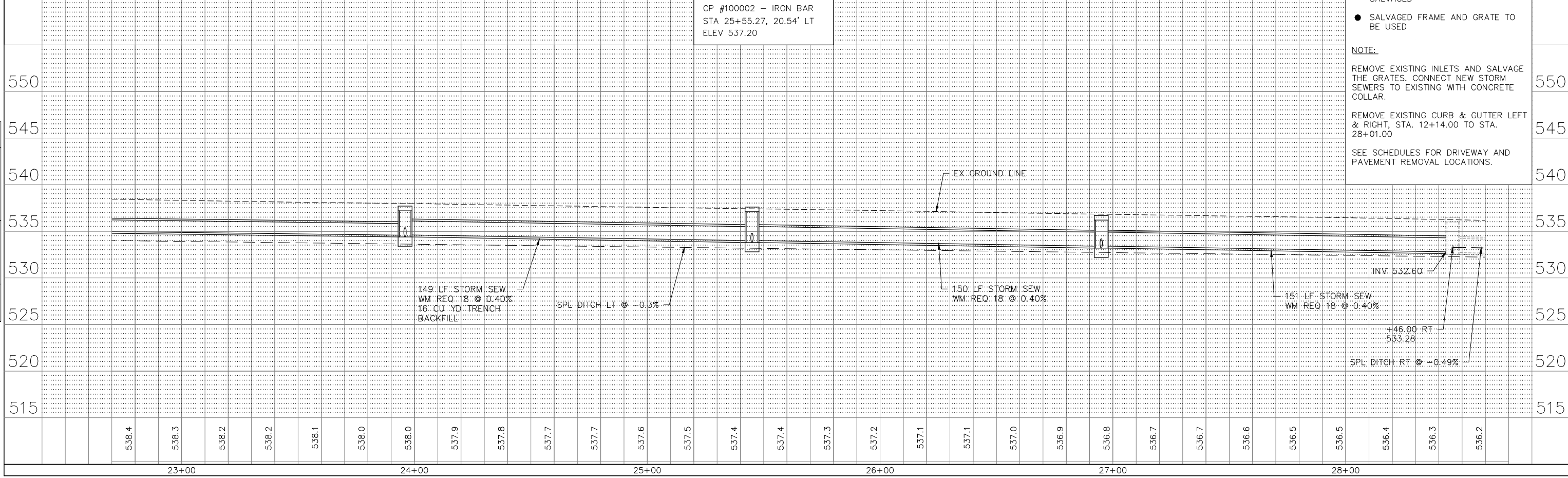

MAIN STREET

F.A.U. RTE.	SECTION	COUNTY	TOTAL SHEETS	SHEET NO.
9330	95-00301-03-PV	ST. CLAIR	166	44
	STA. 9+00	TO STA. 22+00		
FED. ROAD DIST. NO.		ILLINOIS	FED. AID PROJECT	
PLAN AND PROFILE MAIN STREET				
CONTRACT NO.: 97372				

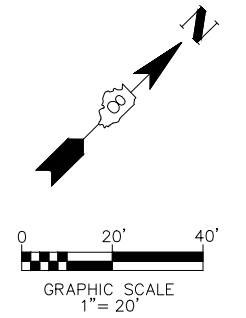
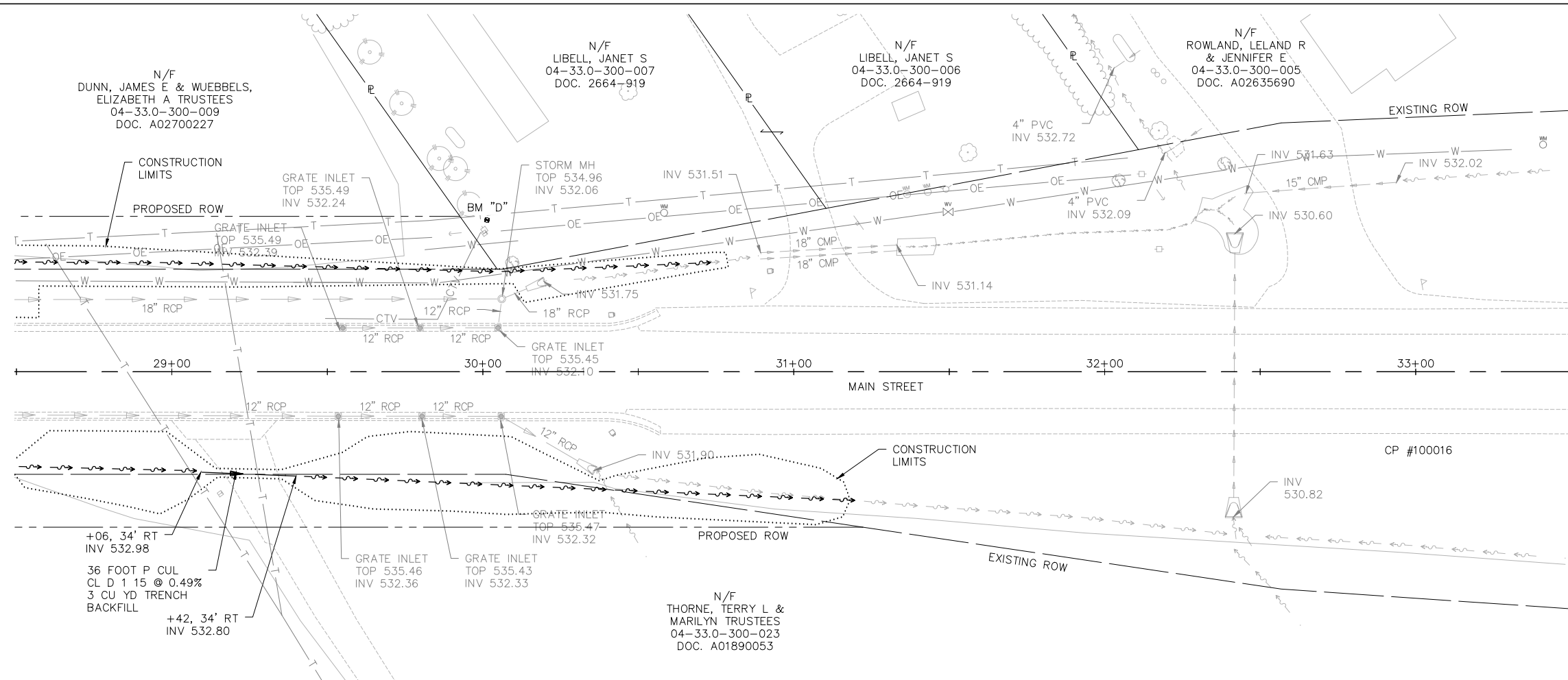

BY	DATE

BY	DATE

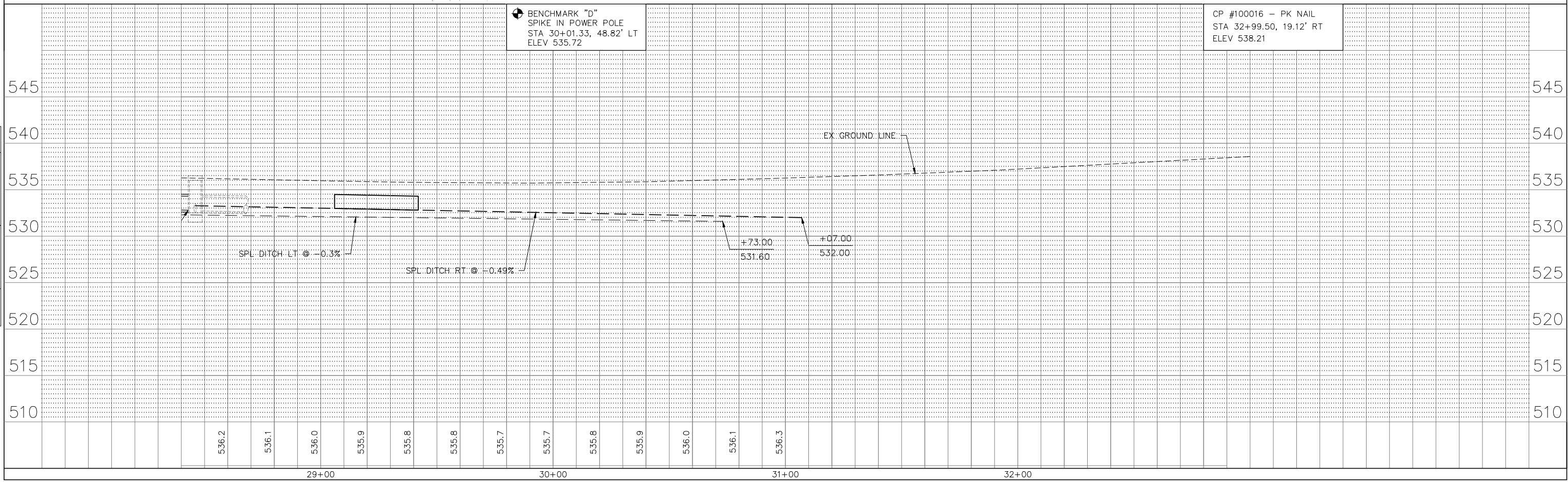

MAIN STREET

F.A.U. RTE.	SECTION	COUNTY	TOTAL SHEETS	SHEET NO.
9330	95-00301-03-PV	ST. CLAIR	166	45
STA. 46+00	TO STA. 57+00			
FED. ROAD DIST. NO.	ILLINOIS	FED. AID PROJECT		
		PLAN AND PROFILE MAPLE STREET, FRONTAGE ROAD, & BOBBIE DRIVE		
CONTRACT NO.: 97372				

SEE INTERSECTION DETAILS SHEET FOR ADDITIONAL INFORMATION SEE PAGE 67

PROPOSED CURVE C8
 PI STA. 52+45.15
 $\Delta = 15'26.57"$
 $R = 938.00'$
 $T = 127.23'$
 $L = 252.92'$
 $E = 8.59'$
 $e = \text{NONE}$
 $PC = 51+17.92$
 $PT = 53+70.84$

PROPOSED CURVE C9
 PI STA. 54+75.86
 $\Delta = 19'51.26"$
 $R = 600.00'$
 $T = 105.02'$
 $L = 207.94'$
 $E = 9.12'$
 $e = \text{NONE}$
 $PC = 53+70.84$
 $PT = 55+78.78$

PROPOSED CURVE C10
 PI STA. 56+95.29
 $\Delta = 17'53.46"$
 $R = 400.00'$
 $T = 62.98'$
 $L = 124.94'$
 $E = 4.93'$
 $e = \text{NONE}$
 $PC = 56+32.31$
 $PT = 57+57.25$

PROPOSED CURVE C5
 PI STA. 47+94.32
 $\Delta = 60'17.17"$
 $R = 340.00'$
 $T = 197.44'$
 $L = 357.76'$
 $E = 53.17'$
 $e = \text{NONE}$
 $PC = 45+96.88$
 $PT = 49+54.64$

2 CENTERED CURVE
 65'-300'
 9' OFFSET
 STA. 240+85.68 FRANK SCOTT & FRONTAGE ROAD

2 CENTERED CURVE
 65'-300'
 9' OFFSET
 STA. 48+35.37 MAPLE STREET STA. 10+00.00 BOBBIE DRIVE

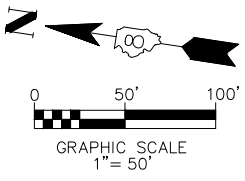
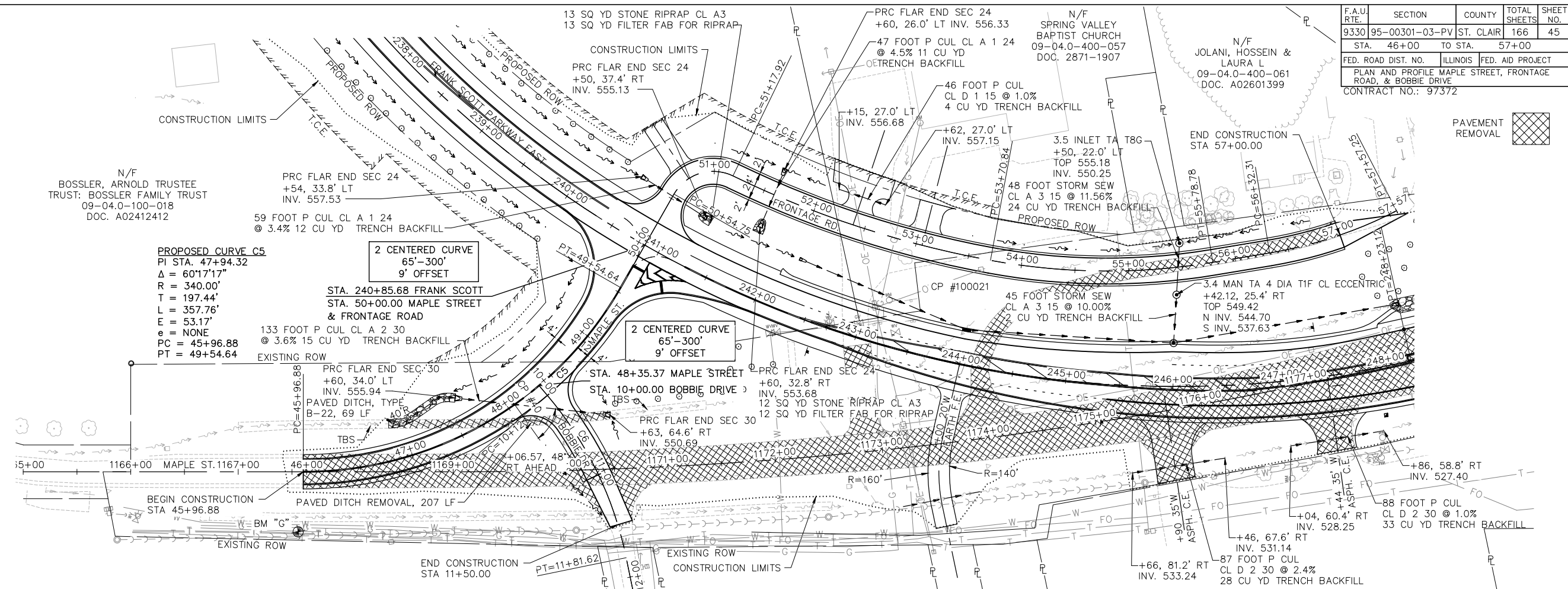

DATE	BY

DATE	BY

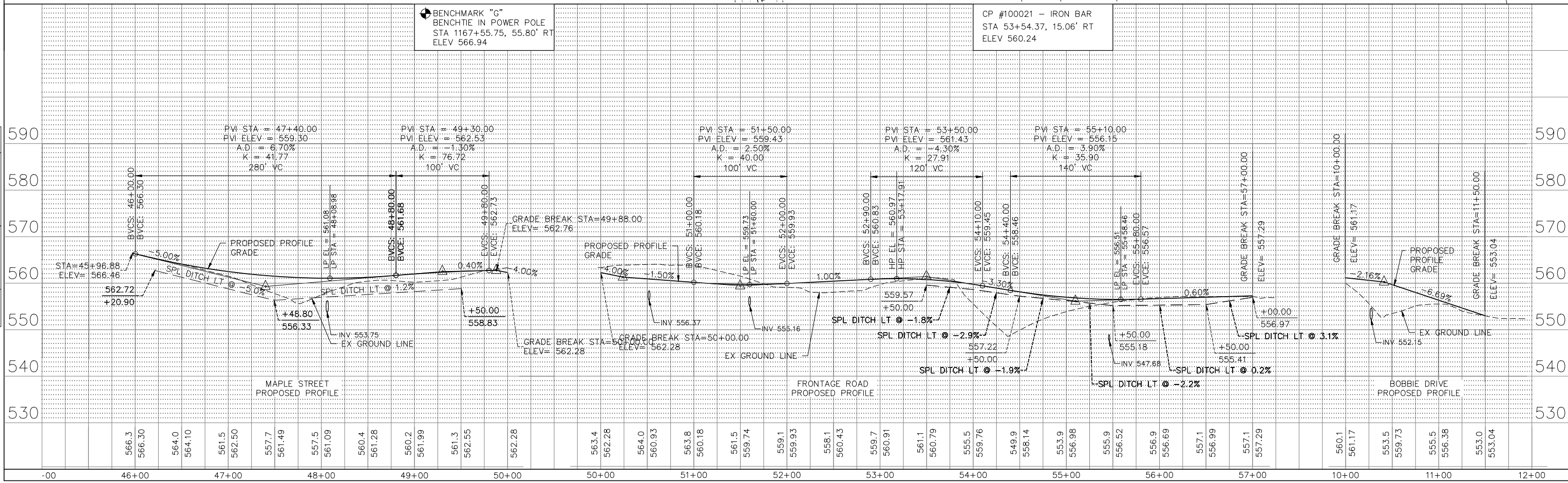

MAPLE STREET, FRONTAGE ROAD, & BOBBIE DRIVE

F.A.U. RTE.	SECTION	COUNTY	TOTAL SHEETS	SHEET NO.
9330	95-00301-03-PV	ST. CLAIR	166	47
STA. 205+00	TO STA. 214+00			
FED. ROAD DIST. NO.		ILLINOIS	FED. AID PROJECT	
PLAN AND PROFILE IL ROUTE 158				
CONTRACT NO.: 97372				

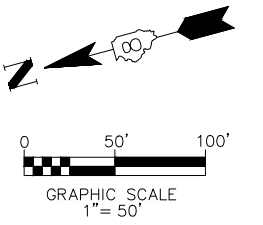

BY	DATE

BY	DATE

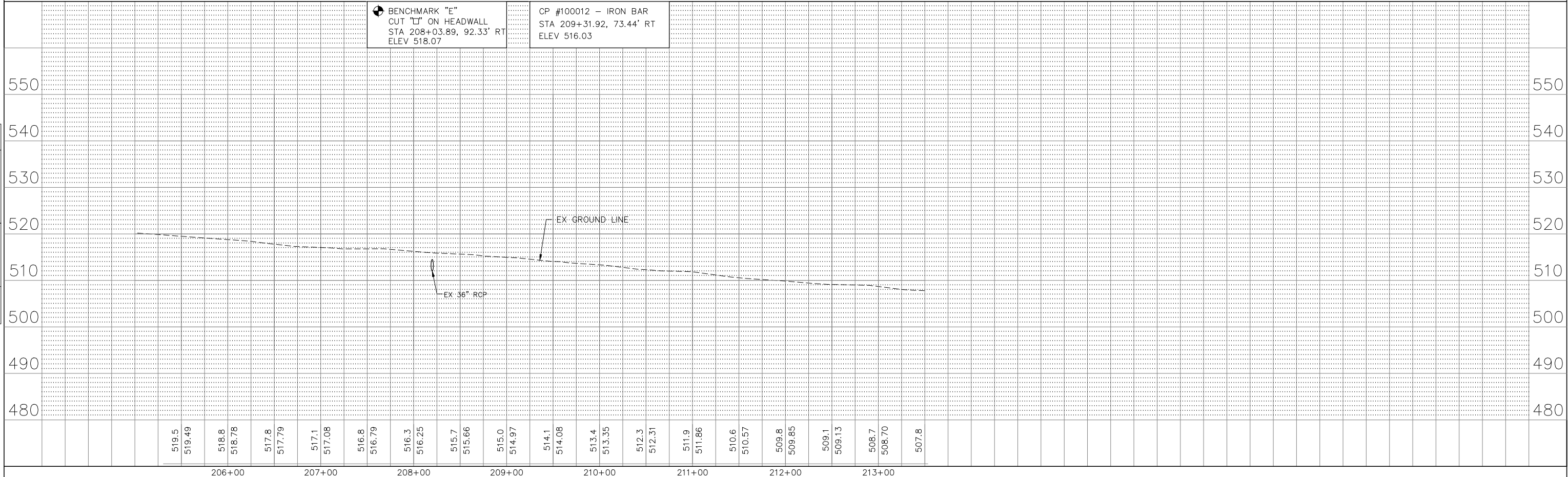
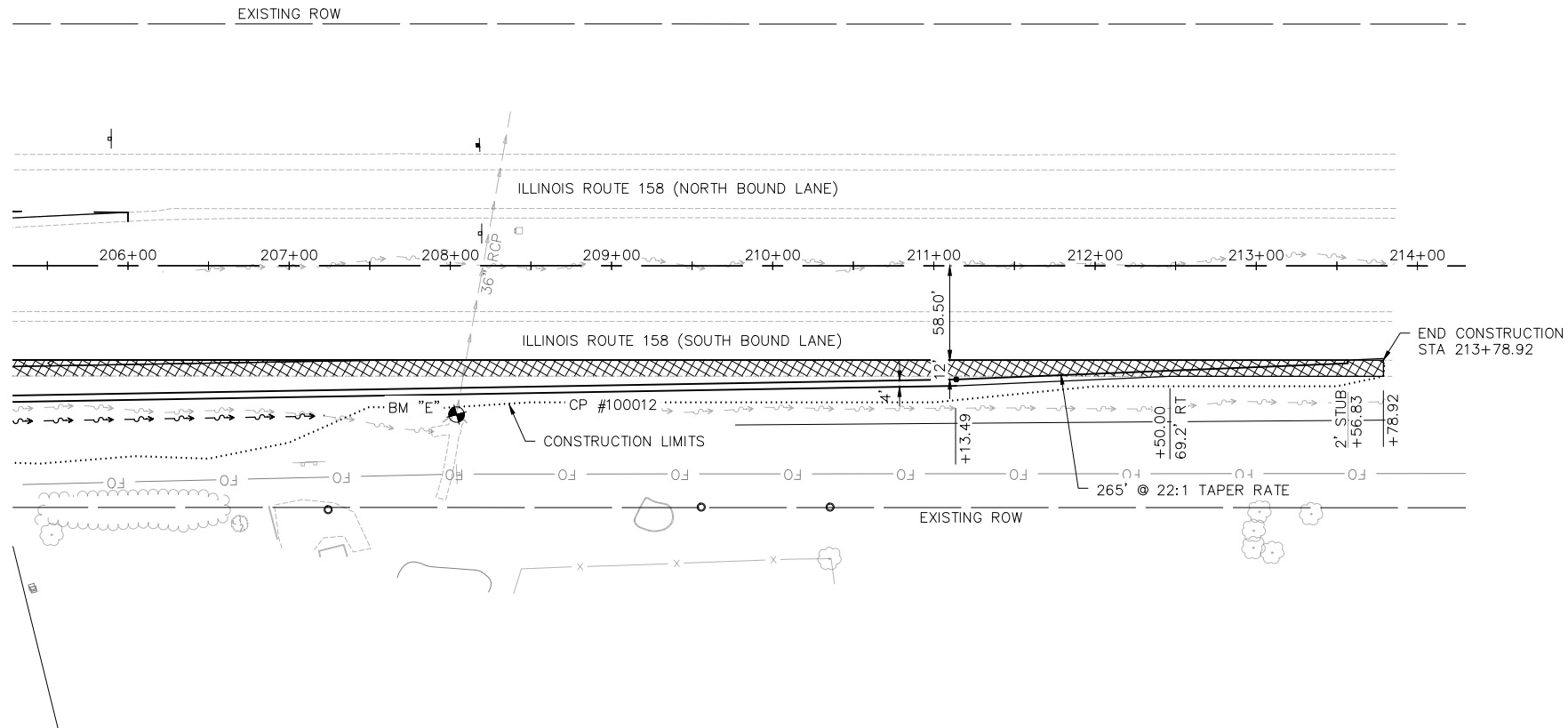

F.A.U. RTE.	SECTION	COUNTY	TOTAL SHEETS	SHEET NO.
9330	95-00301-03-PV	ST. CLAIR	166	48
STA.	0+00	TO STA.	4+34	
FED. ROAD DIST. NO.	ILLINOIS	FED. AID PROJECT		
PLAN AND PROFILE MAPLE STREET DITCH				
CONTRACT NO.: 97372				

N/F
BOSSLER, ARNOLD TRUSTEE
TRUST: BOSSLER FAMILY TRUST
09-04.0-100-018
DOC. A02412412

BY	DATE

BY	DATE

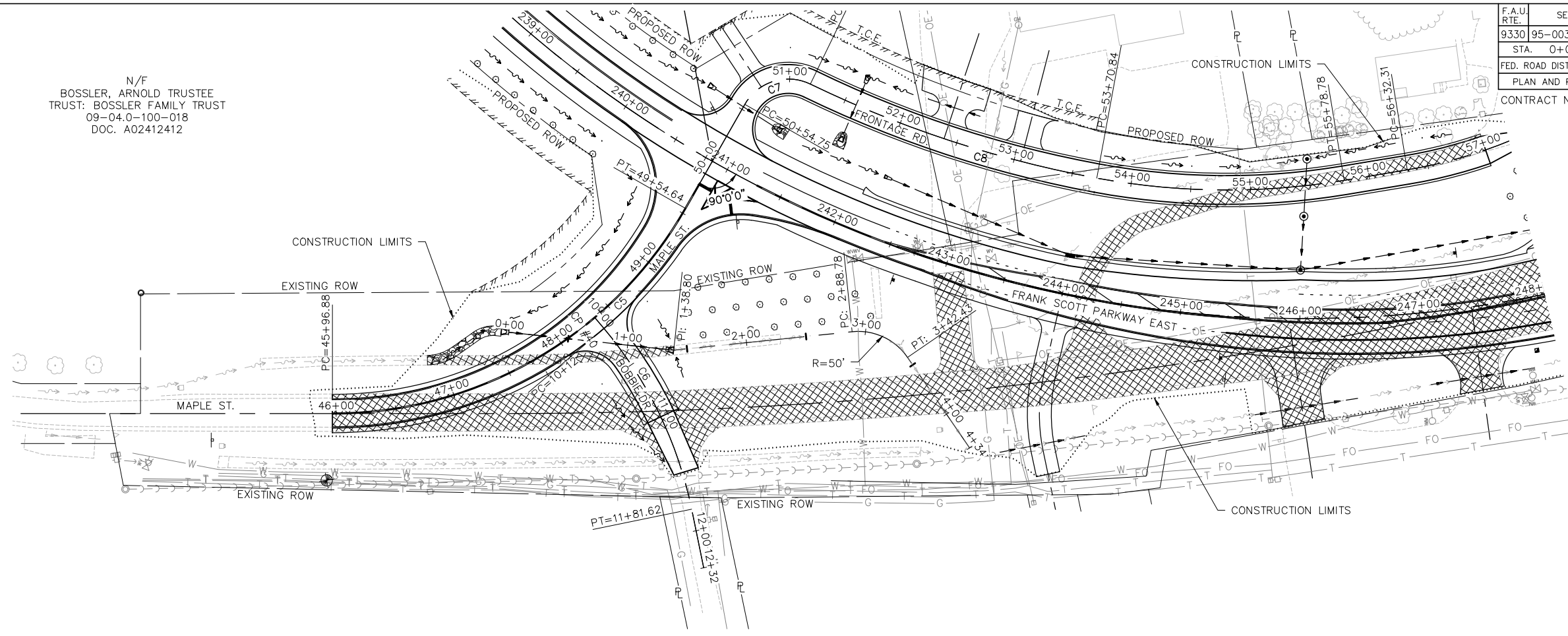
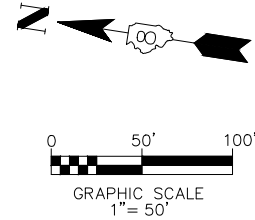

PAVEMENT REMOVAL

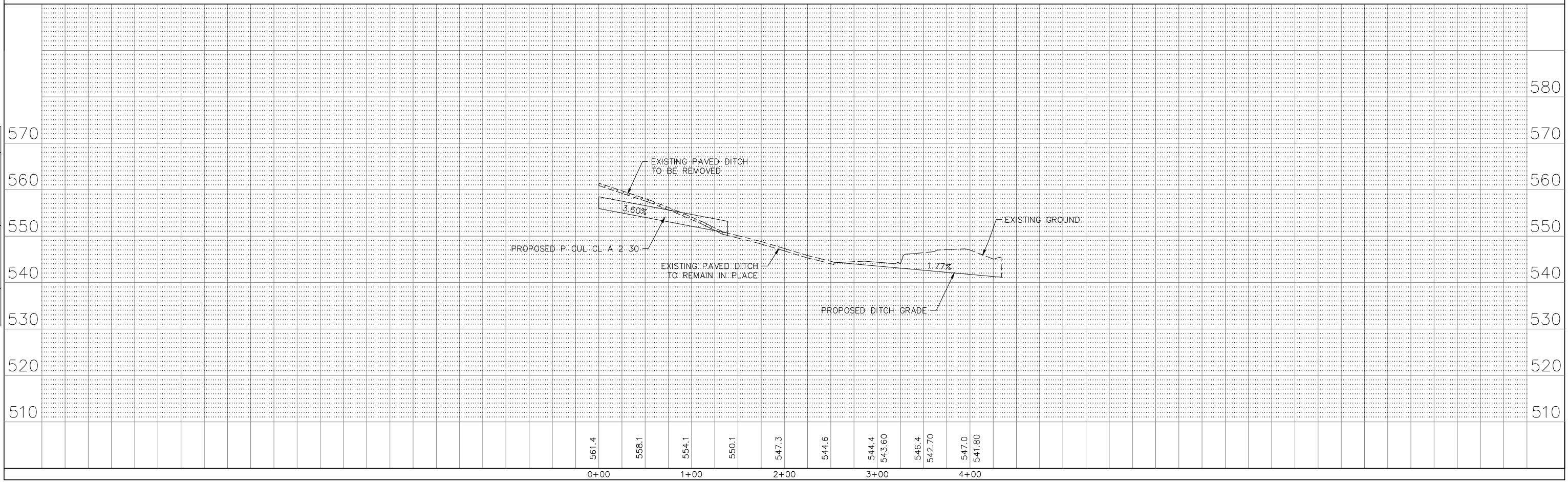





F.A.U. RTE.	SECTION	COUNTY	TOTAL SHEETS	SHEET NO.
9330	95-00301-03-PV	ST. CLAIR	166	49
STA.		TO STA.		
FED. ROAD DIST. NO.		ILLINOIS	FED. AID PROJECT	
TRAFFIC CONTROL				

CONTRACT NO.: 97372

NOTES

1. TYPE III BARRICADES AND ROAD CLOSURE SIGNS SHALL BE POSITIONED AS SHOWN IN ACCORDANCE WITH HIGHWAY STANDARD 701901 AND AS DIRECTED BY THE ENGINEER.
2. TYPE A LOW INTENSITY FLASHING WARNING LIGHTS SHALL BE USED ON EACH SIGN IN ADVANCE OF THE WORK DURING HOURS OF DARKNESS.
3. ALL WARNING SIGNS SHALL BE A MINIMUM OF 48" X 48" AND HAVE A BLACK LEGEND AND BORDER ON A FLUORESCENT ORANGE REFLECTORIZED BACKGROUND.
4. THE CONTRACTOR SHALL MAINTAIN ACCESS TO ENTRANCES AT ALL TIMES.
5. LONGITUDINAL DISTANCES MAY BE ADJUSTED TO FIT FIELD CONDITIONS.
6. ALL TYPE III BARRICADES UTILIZED FOR ROAD CLOSURES SHALL HAVE A LOW INTENSITY FLASHING LIGHT MOUNTED ON TOP OF EACH BARRICADE.
7. ALL RESIDENTS FRONTING THE PROJECT SHALL BE NOTIFIED AT LEAST 48 HOURS PRIOR TO ROAD CLOSURES AFFECTING THEIR ACCESS.
8. SEE HIGHWAY STANDARD 701006 FOR OFF ROAD OPERATIONS 15' TO 24" FROM PAVEMENT EDGE
9. SEE HIGHWAY STANDARD 701326 FOR LANE CLOSURES FOR PAVEMENT WIDENING.
10. SEE HIGHWAY STANDARD B.L.R. 17 AND B.L.R. 22 FOR LANE CLOSURES ON RURAL HIGHWAYS.
11. EXACT LOCATION OF ALL WARNING SIGNS AND BARRICADES SHALL BE STAKED IN THE FIELD FOR APPROVAL BY THE ENGINEER PRIOR TO INSTALLATION.
12. SEE HIGHWAY STANDARD 701422 FOR LANE CLOSURES ALONG SOUTHBOUND ILLINOIS ROUTE 158.
13. SEE HIGHWAY STANDARD 701701 FOR LANE CLOSURES DURING SIGNAL INSTALLATION.

LEGEND

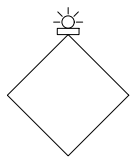
- ◇ ROAD CONSTRUCTION AHEAD W20-1103(0)-48
- ◇ ROAD CLOSED W20-3(0)
- ◇ ROAD CLOSED 500 FT W20-3(0)
- ◇ ROAD CLOSED AHEAD W20-3(0)
- ◇ WORKERS W21-1110(0) (REQUIRED WHEN WORKERS ARE PRESENT)
- ⑤ TYPE III BARRICADES W/ R-11-4-6030 (ROAD CLOSED) SIGNS AND TYPE A LOW INTENSITY FLASHING LIGHTS
- ⑥ TYPE III BARRICADES STAGGERED W/ R-11-4-6030 (ROAD CLOSED TO THRU TRAFFIC) SIGNS AND TYPE A LOW INTENSITY FLASHING LIGHTS
- ⑦ 24" x 24" 
- ⑧ 24" x 24" 
-  TYPE A LOW INTENSITY FLASHING LIGHT
-  WORK ZONE
- ◇ LEFT TURN LANE CLOSED AHEAD W20-1103(0)  48" x 48" FLUORESCENT ORANGE
- ⑩ WORK ZONE SPEED LIMIT BEGINS G20-5aP, R2-1, R2-10, & R2-6bP
- ◇ W4-2R(0)
- ◇ RIGHT LANE CLOSED 1/2 MILE W20-5(0)
- ◇ ROAD CONSTRUCTION 1 MILE W20-1(0)

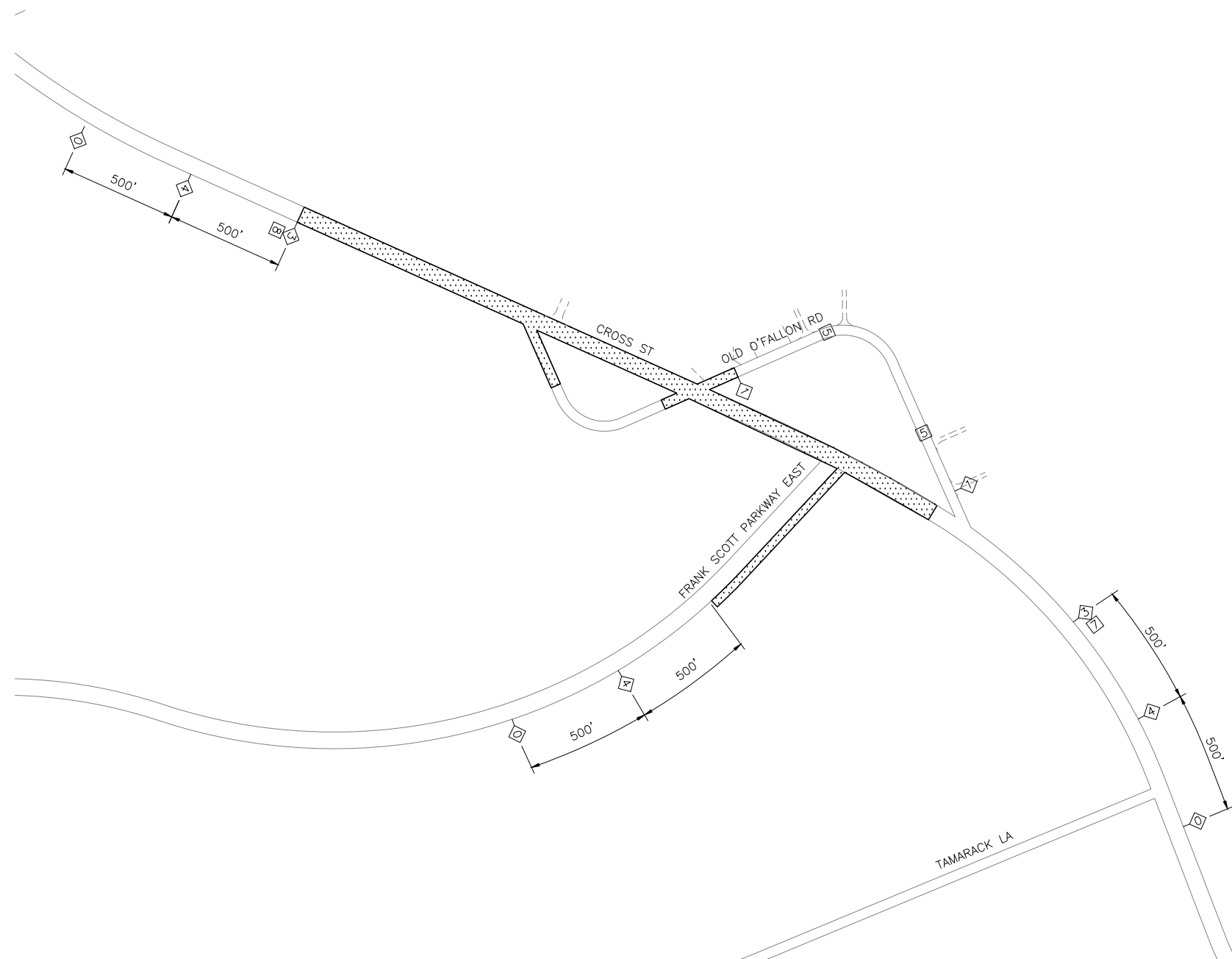

STAGE 1 CONSTRUCTION

NOTE: ALL ASSOCIATED STORM SEWER STRUCTURES AND DRAINAGE GRADING SHALL BE CONSTRUCTED DURING EACH STAGE SO THAT NO EXISTING FLOW IS OBSTRUCTED.

NOT TO SCALE





FINAL SURVEY PLOTTED	BY	DATE
NOTE BOOK TEMPLATE AREAS CHECKED		
NO.		

ORIGINAL SURVEY PLOTTED	BY	DATE
NOTE BOOK TEMPLATE AREAS CHECKED		
NO.		

NOTES

1. TYPE III BARRICADES AND ROAD CLOSURE SIGNS SHALL BE POSITIONED AS SHOWN IN ACCORDANCE WITH HIGHWAY STANDARD 701901 AND AS DIRECTED BY THE ENGINEER.
2. TYPE A LOW INTENSITY FLASHING WARNING LIGHTS SHALL BE USED ON EACH SIGN IN ADVANCE OF THE WORK DURING HOURS OF DARKNESS.
3. ALL WARNING SIGNS SHALL BE A MINIMUM OF 48" X 48" AND HAVE A BLACK LEGEND AND BORDER ON A FLUORESCENT ORANGE REFLECTORIZED BACKGROUND.
4. THE CONTRACTOR SHALL MAINTAIN ACCESS TO ENTRANCES AT ALL TIMES.
5. LONGITUDINAL DISTANCES MAY BE ADJUSTED TO FIT FIELD CONDITIONS.
6. ALL TYPE III BARRICADES UTILIZED FOR ROAD CLOSURES SHALL HAVE A LOW INTENSITY FLASHING LIGHT MOUNTED ON TOP OF EACH BARRICADE.
7. ALL RESIDENTS FRONTING THE PROJECT SHALL BE NOTIFIED AT LEAST 48 HOURS PRIOR TO ROAD CLOSURES AFFECTING THEIR ACCESS.
8. SEE HIGHWAY STANDARD 701006 FOR OFF ROAD OPERATIONS 15' TO 24" FROM PAVEMENT EDGE
9. SEE HIGHWAY STANDARD 701326 FOR LANE CLOSURES FOR PAVEMENT WIDENING.
10. SEE HIGHWAY STANDARD B.L.R. 17 AND B.L.R. 22 FOR LANE CLOSURES ON RURAL HIGHWAYS.
11. EXACT LOCATION OF ALL WARNING SIGNS AND BARRICADES SHALL BE STAKED IN THE FIELD FOR APPROVAL BY THE ENGINEER PRIOR TO INSTALLATION.
12. SEE HIGHWAY STANDARD 701422 FOR LANE CLOSURES ALONG SOUTHBOUND ILLINOIS ROUTE 158.
13. SEE HIGHWAY STANDARD 701701 FOR LANE CLOSURES DURING SIGNAL INSTALLATION.

LEGEND

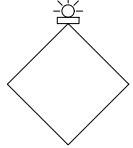
- ◇ ROAD CONSTRUCTION AHEAD W20-1103(0)-48
- ◇ ROAD CLOSED W20-3(0)
- ◇ ROAD CLOSED 500 FT W20-3(0)
- ◇ ROAD CLOSED AHEAD W20-3(0)
- ◇ WORKERS W21-1110(0) (REQUIRED WHEN WORKERS ARE PRESENT)
- 5 TYPE III BARRICADES W/ R-11-4-6030 (ROAD CLOSED TO THRU TRAFFIC) SIGNS AND TYPE A LOW INTENSITY FLASHING LIGHTS
- 7 24" x 24" 
- 8 24" x 24" 
-  TYPE A LOW INTENSITY FLASHING LIGHT
-  WORK ZONE
- ◇ LEFT TURN LANE CLOSED AHEAD W20-1103(0) 
- 10 WORK ZONE SPEED LIMIT BEGINS G20-5aP, R2-1, R2-10, & R2-6bP
- ◇ W4-2R(0)
- ◇ RIGHT LANE CLOSED 1/2 MILE W20-5(0)
- ◇ ROAD CONSTRUCTION 1 MILE W20-1(0)

NOTE: ALL ASSOCIATED STORM SEWER STRUCTURES AND DRAINAGE GRADING SHALL BE CONSTRUCTED DURING EACH STAGE SO THAT NO EXISTING FLOW IS OBSTRUCTED.

F.A.U. RTE.	SECTION	COUNTY	TOTAL SHEETS	SHEET NO.
9330	95-00301-03-PV	ST. CLAIR	166	50
STA.	TO STA.			
FED. ROAD DIST. NO.	ILLINOIS	FED. AID PROJECT		
TRAFFIC CONTROL				

CONTRACT NO.: 97372

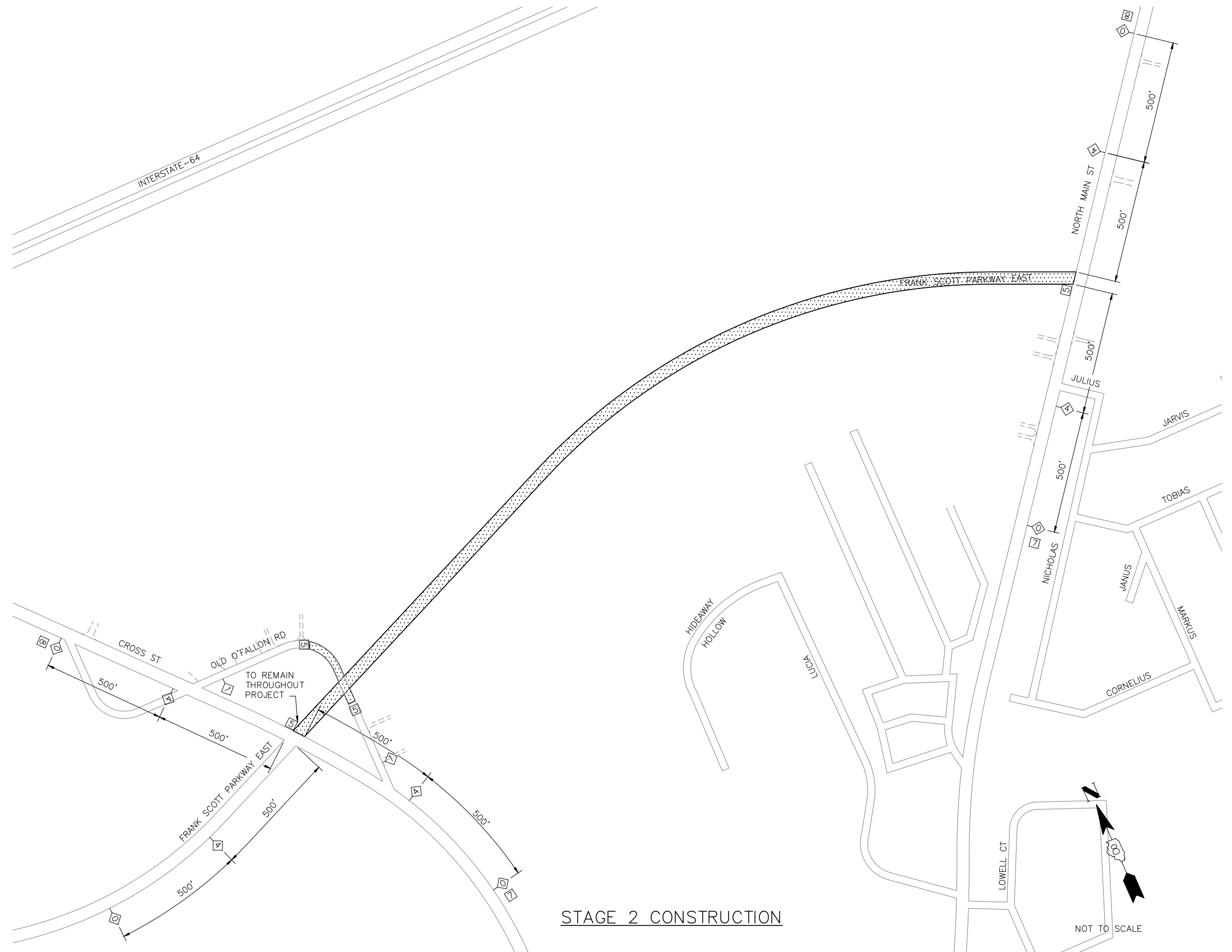

STAGE 2 CONSTRUCTION

NOT TO SCALE

BY	DATE

BY	DATE

NOTES

1. TYPE III BARRICADES AND ROAD CLOSURE SIGNS SHALL BE POSITIONED AS SHOWN IN ACCORDANCE WITH HIGHWAY STANDARD 701901 AND AS DIRECTED BY THE ENGINEER.
2. TYPE A LOW INTENSITY FLASHING WARNING LIGHTS SHALL BE USED ON EACH SIGN IN ADVANCE OF THE WORK DURING HOURS OF DARKNESS.
3. ALL WARNING SIGNS SHALL BE A MINIMUM OF 48" X 48" AND HAVE A BLACK LEGEND AND BORDER ON A FLUORESCENT ORANGE REFLECTORIZED BACKGROUND.
4. THE CONTRACTOR SHALL MAINTAIN ACCESS TO ENTRANCES AT ALL TIMES.
5. LONGITUDINAL DISTANCES MAY BE ADJUSTED TO FIT FIELD CONDITIONS.
6. ALL TYPE III BARRICADES UTILIZED FOR ROAD CLOSURES SHALL HAVE A LOW INTENSITY FLASHING LIGHT MOUNTED ON TOP OF EACH BARRICADE.
7. ALL RESIDENTS FRONTING THE PROJECT SHALL BE NOTIFIED AT LEAST 48 HOURS PRIOR TO ROAD CLOSURES AFFECTING THEIR ACCESS.
8. SEE HIGHWAY STANDARD 701006 FOR OFF ROAD OPERATIONS 15' TO 24" FROM PAVEMENT EDGE
9. SEE HIGHWAY STANDARD 701326 FOR LANE CLOSURES FOR PAVEMENT WIDENING.
10. SEE HIGHWAY STANDARD B.L.R. 17 AND B.L.R. 22 FOR LANE CLOSURES ON RURAL HIGHWAYS.
11. EXACT LOCATION OF ALL WARNING SIGNS AND BARRICADES SHALL BE STAKED IN THE FIELD FOR APPROVAL BY THE ENGINEER PRIOR TO INSTALLATION.
12. SEE HIGHWAY STANDARD 701422 FOR LANE CLOSURES ALONG SOUTHBOUND ILLINOIS ROUTE 158.
13. SEE HIGHWAY STANDARD 701701 FOR LANE CLOSURES DURING SIGNAL INSTALLATION.

LEGEND

- ◇ ROAD CONSTRUCTION AHEAD W20-1103(0)-48
- ◇ ROAD CLOSED W20-3(0)
- ◇ ROAD CLOSED 500 FT W20-3(0)
- ◇ ROAD CLOSED AHEAD W20-3(0)
- ◇ WORKERS W21-1110(0) (REQUIRED WHEN WORKERS ARE PRESENT)
- ⑤ TYPE III BARRICADES W/ R-11-4-6030 (ROAD CLOSED) SIGNS AND TYPE A LOW INTENSITY FLASHING LIGHTS
- ⑥ TYPE III BARRICADES STAGGERED W/ R-11-4-6030 (ROAD CLOSED TO THRU TRAFFIC) SIGNS AND TYPE A LOW INTENSITY FLASHING LIGHTS
- ⑦ 24" x 24"
- ⑧ 24" x 24"
- TYPE A LOW INTENSITY FLASHING LIGHT
- WORK ZONE
- ◇ LEFT TURN LANE CLOSED AHEAD W20-1103(0)
- ⑩ WORK ZONE SPEED LIMIT BEGINS G20-5aP, R2-1, R2-10, & R2-6bP
- ◇ W4-2R(0)
- ◇ RIGHT LANE CLOSED 1/2 MILE W20-5(0)
- ◇ ROAD CONSTRUCTION 1 MILE W20-1(0)

FINAL SURVEY PLOTTED	BY	DATE
NOTE BOOK TEMPLATE		
AREAS CHECKED		
NO.		

ORIGINAL SURVEY PLOTTED	BY	DATE
NOTE BOOK TEMPLATE		
AREAS CHECKED		
NO.		

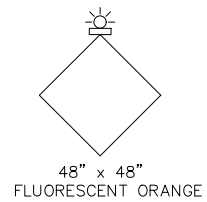

F.A.U. RTE.	SECTION	COUNTY	TOTAL SHEETS	SHEET NO.
9330	95-00301-03-PV	ST. CLAIR	166	51
STA.		TO STA.		
FED. ROAD DIST. NO.		ILLINOIS FED. AID PROJECT		
TRAFFIC CONTROL				

CONTRACT NO.: 97372

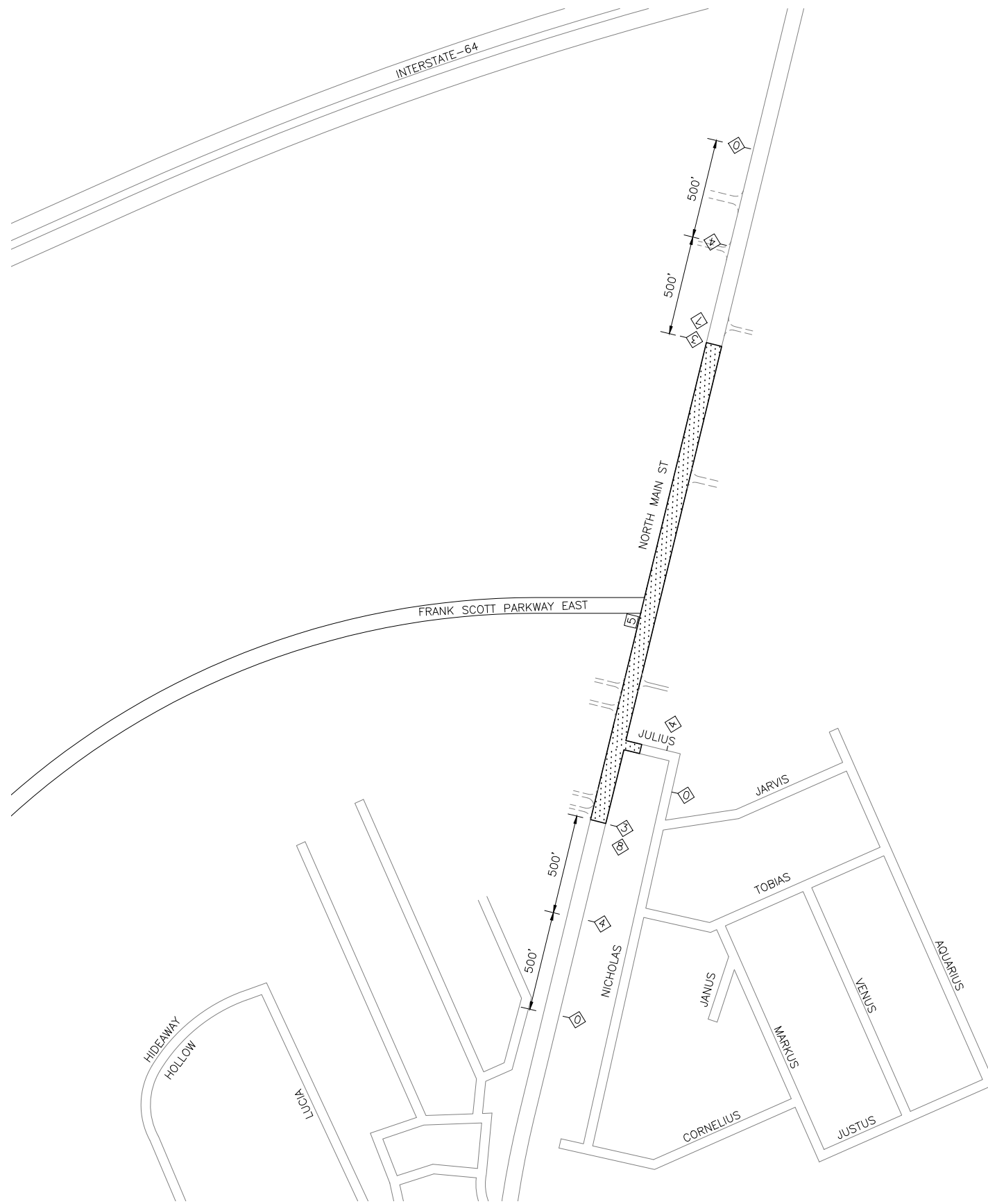

NOTE: ALL ASSOCIATED STORM SEWER STRUCTURES AND DRAINAGE GRADING SHALL BE CONSTRUCTED DURING EACH STAGE SO THAT NO EXISTING FLOW IS OBSTRUCTED.

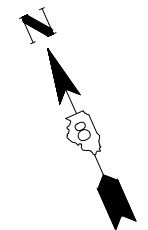

NOT TO SCALE





F.A.U. RTE.	SECTION	COUNTY	TOTAL SHEETS	SHEET NO.
9330	95-00301-03-PV	ST. CLAIR	166	52
STA.		TO STA.		
FED. ROAD DIST. NO.		ILLINOIS	FED. AID PROJECT	
TRAFFIC CONTROL				

CONTRACT NO.: 97372

NOTES

1. TYPE III BARRICADES AND ROAD CLOSURE SIGNS SHALL BE POSITIONED AS SHOWN IN ACCORDANCE WITH HIGHWAY STANDARD 701901 AND AS DIRECTED BY THE ENGINEER.
2. TYPE A LOW INTENSITY FLASHING WARNING LIGHTS SHALL BE USED ON EACH SIGN IN ADVANCE OF THE WORK DURING HOURS OF DARKNESS.
3. ALL WARNING SIGNS SHALL BE A MINIMUM OF 48" X 48" AND HAVE A BLACK LEGEND AND BORDER ON A FLUORESCENT ORANGE REFLECTORIZED BACKGROUND.
4. THE CONTRACTOR SHALL MAINTAIN ACCESS TO ENTRANCES AT ALL TIMES.
5. LONGITUDINAL DISTANCES MAY BE ADJUSTED TO FIT FIELD CONDITIONS.
6. ALL TYPE III BARRICADES UTILIZED FOR ROAD CLOSURES SHALL HAVE A LOW INTENSITY FLASHING LIGHT MOUNTED ON TOP OF EACH BARRICADE.
7. ALL RESIDENTS FRONTING THE PROJECT SHALL BE NOTIFIED AT LEAST 48 HOURS PRIOR TO ROAD CLOSURES AFFECTING THEIR ACCESS.
8. SEE HIGHWAY STANDARD 701006 FOR OFF ROAD OPERATIONS 15' TO 24" FROM PAVEMENT EDGE
9. SEE HIGHWAY STANDARD 701326 FOR LANE CLOSURES FOR PAVEMENT WIDENING.
10. SEE HIGHWAY STANDARD B.L.R. 17 AND B.L.R. 22 FOR LANE CLOSURES ON RURAL HIGHWAYS.
11. EXACT LOCATION OF ALL WARNING SIGNS AND BARRICADES SHALL BE STAKED IN THE FIELD FOR APPROVAL BY THE ENGINEER PRIOR TO INSTALLATION.
12. SEE HIGHWAY STANDARD 701422 FOR LANE CLOSURES ALONG SOUTHBOUND ILLINOIS ROUTE 158.
13. SEE HIGHWAY STANDARD 701701 FOR LANE CLOSURES DURING SIGNAL INSTALLATION.

LEGEND

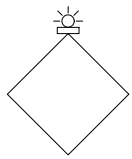
- ◇ ROAD CONSTRUCTION AHEAD W20-1103(0)-48
- ◇ ROAD CLOSED W20-3(0)
- ◇ ROAD CLOSED 500 FT W20-3(0)
- ◇ ROAD CLOSED AHEAD W20-3(0)
- ◇ WORKERS W21-1110(0) (REQUIRED WHEN WORKERS ARE PRESENT)
- ⑤ TYPE III BARRICADES W/ R-11-4-6030 (ROAD CLOSED) SIGNS AND TYPE A LOW INTENSITY FLASHING LIGHTS
- ⑥ TYPE III BARRICADES STAGGERED W/ R-11-4-6030 (ROAD CLOSED TO THRU TRAFFIC) SIGNS AND TYPE A LOW INTENSITY FLASHING LIGHTS
- ⑦ 24" x 24" 
- ⑧ 24" x 24" 
-  TYPE A LOW INTENSITY FLASHING LIGHT
-  WORK ZONE
- ◇ LEFT TURN LANE CLOSED AHEAD W20-1103(0)  48" x 48" FLUORESCENT ORANGE
- ⑩ WORK ZONE SPEED LIMIT BEGINS G20-5aP, R2-1, R2-10, & R2-6bP
- ◇ W4-2R(0)
- ◇ RIGHT LANE CLOSED 1/2 MILE W20-5(0)
- ◇ ROAD CONSTRUCTION 1 MILE W20-1(0)



STAGE 4 CONSTRUCTION

NOTE: ALL ASSOCIATED STORM SEWER STRUCTURES AND DRAINAGE GRADING SHALL BE CONSTRUCTED DURING EACH STAGE SO THAT NO EXISTING FLOW IS OBSTRUCTED.

NOT TO SCALE

FINAL SURVEY PLOTTED	BY	DATE
NOTE BOOK TEMPLATE		
AREAS CHECKED		
NO.		

ORIGINAL SURVEY PLOTTED	BY	DATE
NOTE BOOK TEMPLATE		
AREAS CHECKED		
NO.		





F.A.U. RTE.	SECTION	COUNTY	TOTAL SHEETS	SHEET NO.
9330	95-00301-03-PV	ST. CLAIR	166	53
STA.		TO STA.		
FED. ROAD DIST. NO.		ILLINOIS FED. AID PROJECT		
TRAFFIC CONTROL				

CONTRACT NO.: 97372

NOTES

- TYPE III BARRICADES AND ROAD CLOSURE SIGNS SHALL BE POSITIONED AS SHOWN IN ACCORDANCE WITH HIGHWAY STANDARD 701901 AND AS DIRECTED BY THE ENGINEER.
- TYPE A LOW INTENSITY FLASHING WARNING LIGHTS SHALL BE USED ON EACH SIGN IN ADVANCE OF THE WORK DURING HOURS OF DARKNESS.
- ALL WARNING SIGNS SHALL BE A MINIMUM OF 48" X 48" AND HAVE A BLACK LEGEND AND BORDER ON A FLUORESCENT ORANGE REFLECTORIZED BACKGROUND.
- THE CONTRACTOR SHALL MAINTAIN ACCESS TO ENTRANCES AT ALL TIMES.
- LONGITUDINAL DISTANCES MAY BE ADJUSTED TO FIT FIELD CONDITIONS.
- ALL TYPE III BARRICADES UTILIZED FOR ROAD CLOSURES SHALL HAVE A LOW INTENSITY FLASHING LIGHT MOUNTED ON TOP OF EACH BARRICADE.
- ALL RESIDENTS FRONTING THE PROJECT SHALL BE NOTIFIED AT LEAST 48 HOURS PRIOR TO ROAD CLOSURES AFFECTING THEIR ACCESS.
- SEE HIGHWAY STANDARD 701006 FOR OFF ROAD OPERATIONS 15' TO 24" FROM PAVEMENT EDGE
- SEE HIGHWAY STANDARD 701326 FOR LANE CLOSURES FOR PAVEMENT WIDENING.
- SEE HIGHWAY STANDARD B.L.R. 17 AND B.L.R. 22 FOR LANE CLOSURES ON RURAL HIGHWAYS.
- EXACT LOCATION OF ALL WARNING SIGNS AND BARRICADES SHALL BE STAKED IN THE FIELD FOR APPROVAL BY THE ENGINEER PRIOR TO INSTALLATION.
- SEE HIGHWAY STANDARD 701422 FOR LANE CLOSURES ALONG SOUTHBOUND ILLINOIS ROUTE 158.
- SEE HIGHWAY STANDARD 701701 FOR LANE CLOSURES DURING SIGNAL INSTALLATION.

LEGEND

- ◇ ROAD CONSTRUCTION AHEAD W20-1103(0)-48
- ◇ ROAD CLOSED W20-3(0)
- ◇ ROAD CLOSED 500 FT W20-3(0)
- ◇ ROAD CLOSED AHEAD W20-3(0)
- ◇ WORKERS W21-1110(0) (REQUIRED WHEN WORKERS ARE PRESENT)
- ⑤ TYPE III BARRICADES W/ R-11-4-6030 (ROAD CLOSED) SIGNS AND TYPE A LOW INTENSITY FLASHING LIGHTS
- ⑥ TYPE III BARRICADES STAGGERED W/ R-11-4-6030 (ROAD CLOSED TO THRU TRAFFIC) SIGNS AND TYPE A LOW INTENSITY FLASHING LIGHTS
- ⑦ 24" x 24" 
- ⑧ 24" x 24" 
-  TYPE A LOW INTENSITY FLASHING LIGHT
-  WORK ZONE
- ◇ LEFT TURN LANE CLOSED AHEAD W20-1103(0)
- ⑩ WORK ZONE SPEED LIMIT BEGINS G20-5aP, R2-1, R2-10, & R2-6bP
- ◇ W4-2R(0)
- ◇ RIGHT LANE CLOSED 1/2 MILE W20-5(0)
- ◇ ROAD CONSTRUCTION 1 MILE W20-1(0)

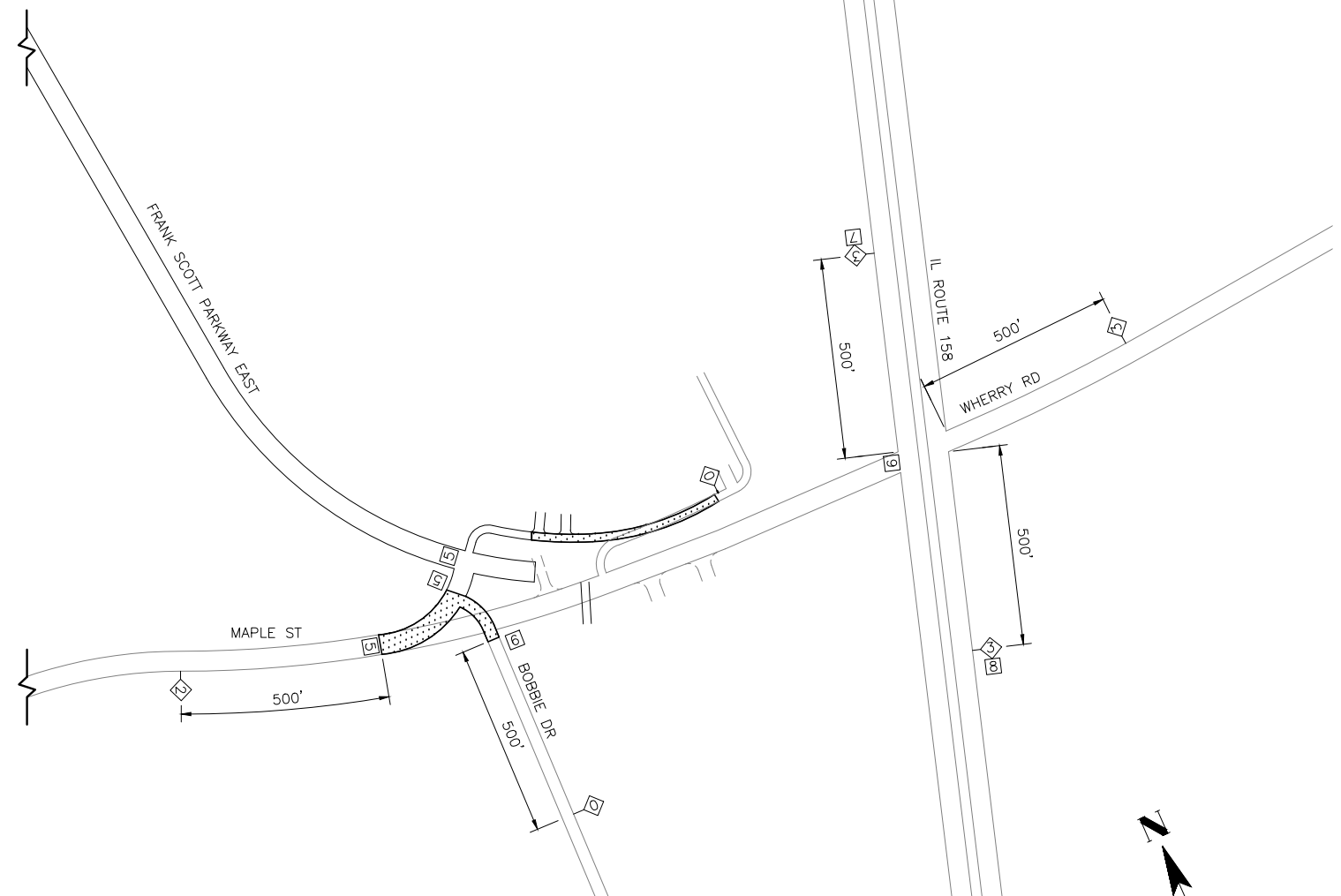
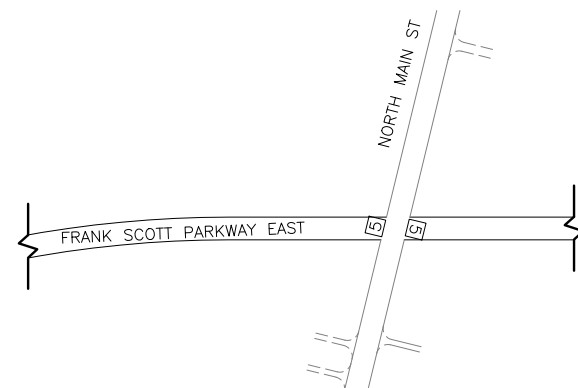
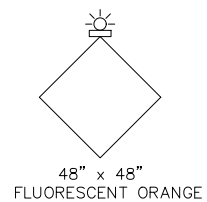

STAGE 5 CONSTRUCTION

NOTE: ALL ASSOCIATED STORM SEWER STRUCTURES AND DRAINAGE GRADING SHALL BE CONSTRUCTED DURING EACH STAGE SO THAT NO EXISTING FLOW IS OBSTRUCTED.

NOT TO SCALE

FINAL SURVEYED	BY	DATE
SURVEY PLOTTED		
NOTE BOOK TEMPLATE		
AREAS CHECKED		
NO.		

ORIGINAL SURVEYED	BY	DATE
SURVEY PLOTTED		
NOTE BOOK TEMPLATE		
AREAS CHECKED		
NO.		





F.A.U. RTE.	SECTION	COUNTY	TOTAL SHEETS	SHEET NO.
9330	95-00301-03-PV	ST. CLAIR	166	54
STA.		TO STA.		
FED. ROAD DIST. NO.		ILLINOIS FED. AID PROJECT		
TRAFFIC CONTROL				

CONTRACT NO.: 97372

NOTES

- TYPE III BARRICADES AND ROAD CLOSURE SIGNS SHALL BE POSITIONED AS SHOWN IN ACCORDANCE WITH HIGHWAY STANDARD 701901 AND AS DIRECTED BY THE ENGINEER.
- TYPE A LOW INTENSITY FLASHING WARNING LIGHTS SHALL BE USED ON EACH SIGN IN ADVANCE OF THE WORK DURING HOURS OF DARKNESS.
- ALL WARNING SIGNS SHALL BE A MINIMUM OF 48" X 48" AND HAVE A BLACK LEGEND AND BORDER ON A FLUORESCENT ORANGE REFLECTORIZED BACKGROUND.
- THE CONTRACTOR SHALL MAINTAIN ACCESS TO ENTRANCES AT ALL TIMES.
- LONGITUDINAL DISTANCES MAY BE ADJUSTED TO FIT FIELD CONDITIONS.
- ALL TYPE III BARRICADES UTILIZED FOR ROAD CLOSURES SHALL HAVE A LOW INTENSITY FLASHING LIGHT MOUNTED ON TOP OF EACH BARRICADE.
- ALL RESIDENTS FRONTING THE PROJECT SHALL BE NOTIFIED AT LEAST 48 HOURS PRIOR TO ROAD CLOSURES AFFECTING THEIR ACCESS.
- SEE HIGHWAY STANDARD 701006 FOR OFF ROAD OPERATIONS 15' TO 24" FROM PAVEMENT EDGE
- SEE HIGHWAY STANDARD 701326 FOR LANE CLOSURES FOR PAVEMENT WIDENING.
- SEE HIGHWAY STANDARD B.L.R. 17 AND B.L.R. 22 FOR LANE CLOSURES ON RURAL HIGHWAYS.
- EXACT LOCATION OF ALL WARNING SIGNS AND BARRICADES SHALL BE STAKED IN THE FIELD FOR APPROVAL BY THE ENGINEER PRIOR TO INSTALLATION.
- SEE HIGHWAY STANDARD 701422 FOR LANE CLOSURES ALONG SOUTHBOUND ILLINOIS ROUTE 158.
- SEE SPECIAL PROVISION TRAFFIC CONTROL AND PROTECTION FOR AM PEAK HOUR RESTRICTIONS ON IL RTE 158.
- SEE HIGHWAY STANDARD 701701 FOR LANE CLOSURES DURING SIGNAL INSTALLATION.

LEGEND

- ◇ ROAD CONSTRUCTION AHEAD W20-1103(0)-48
- ◇ ROAD CLOSED W20-3(0)
- ◇ ROAD CLOSED 500 FT W20-3(0)
- ◇ ROAD CLOSED AHEAD W20-3(0)
- ◇ WORKERS W21-1110(0) (REQUIRED WHEN WORKERS ARE PRESENT)
- ⑤ TYPE III BARRICADES W/ R-11-4-6030 (ROAD CLOSED) SIGNS AND TYPE A LOW INTENSITY FLASHING LIGHTS
- ⑥ TYPE III BARRICADES STAGGERED W/ R-11-4-6030 (ROAD CLOSED TO THRU TRAFFIC) SIGNS AND TYPE A LOW INTENSITY FLASHING LIGHTS
- ⑦ 24" x 24" 
- ⑧ 24" x 24" 
-  TYPE A LOW INTENSITY FLASHING LIGHT
-  WORK ZONE
- ◇ LEFT TURN LANE CLOSED AHEAD W20-1103(0)
- ⑩ WORK ZONE SPEED LIMIT BEGINS G20-5aP, R2-1, R2-10, & R2-6bP
- ◇ W4-2R(0)
- ◇ RIGHT LANE CLOSED 1/2 MILE W20-5(0)
- ◇ ROAD CONSTRUCTION 1 MILE W20-1(0)

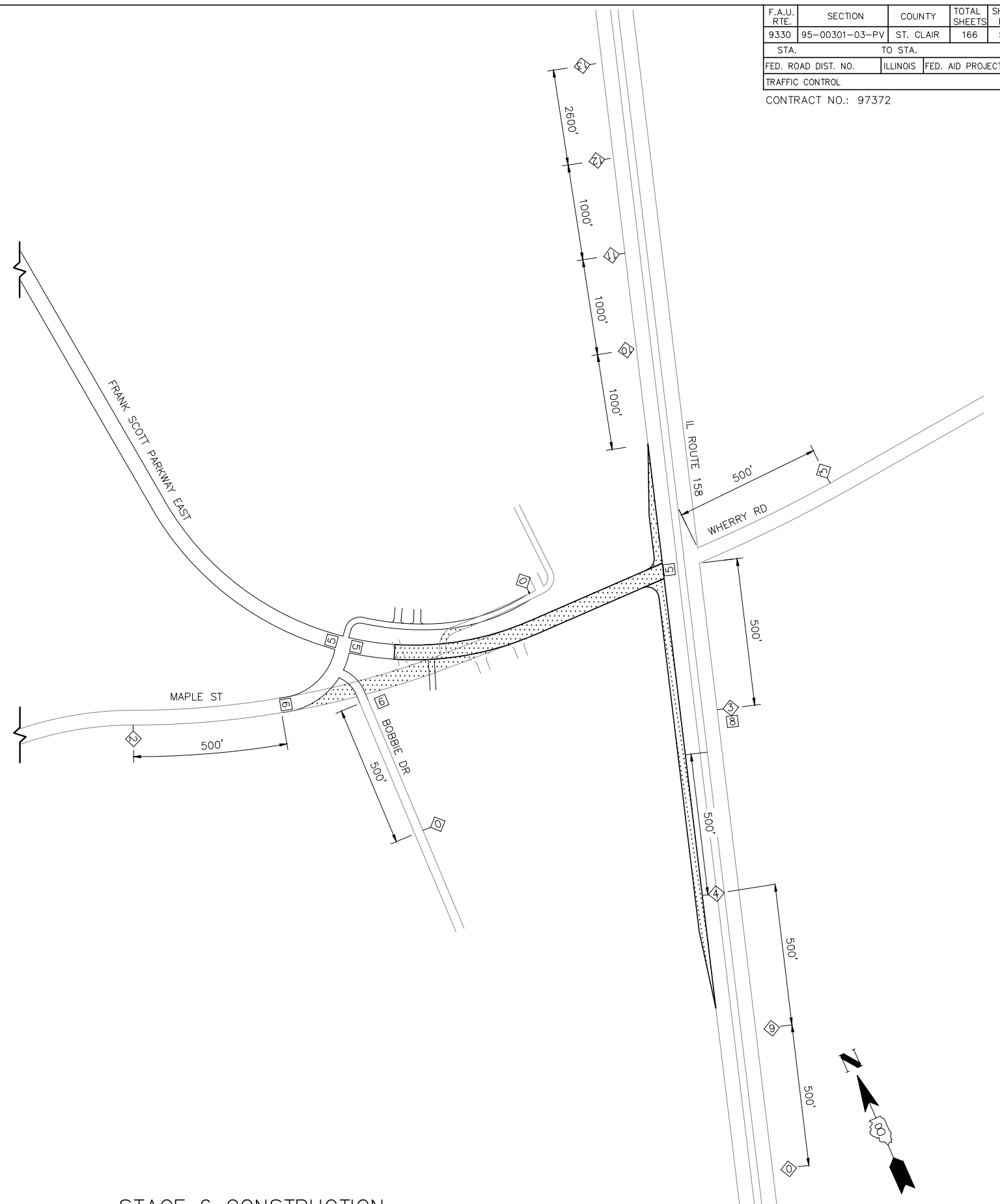
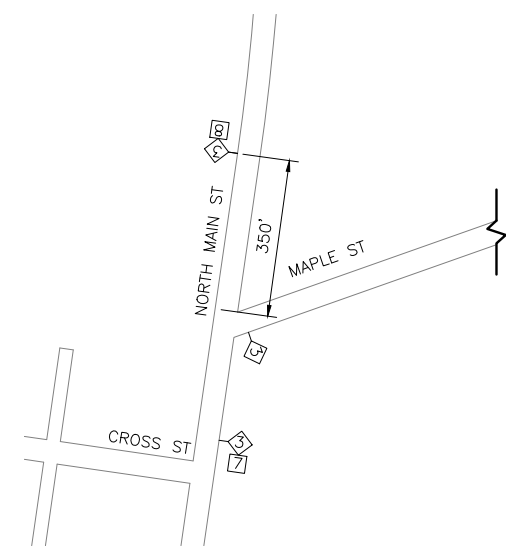
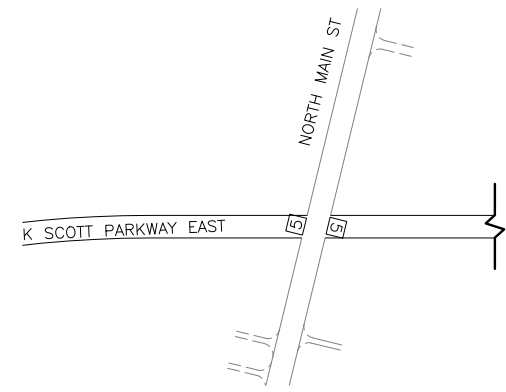
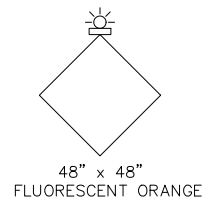

STAGE 6 CONSTRUCTION

NOTE: ALL ASSOCIATED STORM SEWER STRUCTURES AND DRAINAGE GRADING SHALL BE CONSTRUCTED DURING EACH STAGE SO THAT NO EXISTING FLOW IS OBSTRUCTED.

NOT TO SCALE

FINAL SURVEYED	DATE
SURVEY PLOTTED	
NOTE BOOK TEMPLATE	
AREAS CHECKED	
NO.	

ORIGINAL SURVEYED	DATE
SURVEY PLOTTED	
NOTE BOOK TEMPLATE	
AREAS CHECKED	
NO.	

F.A.U. RT.	SECTION	COUNTY	TOTAL SHEETS	SHEET NO.
9330	95-00301-03-PV	ST. CLAIR	166	55
	STA. 153+00	TO STA.	179+00	
FED. ROAD DIST. NO.		ILLINOIS	FED. AID PROJECT	
EROSION CONTROL PLAN				
CONTRACT NO.: 97372				

LEGEND

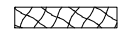
- LIMITS OF CONSTRUCTION
- ▽ TEMPORARY DITCH CHECK
-  RIPRAP
-  EROSION CONTROL BLANKET
- PERIMETER EROSION BARRIER— SILT FILTER FENCE OR OTHER AS APPROVED BY THE ENGINEER
- ◆ INLET AND PIPE PROTECTION

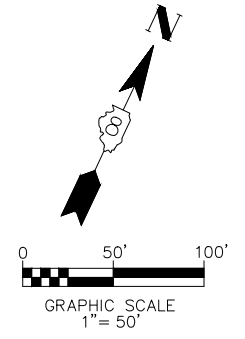

DITCH CHECK SPACING

SLOPE (%)	HEIGHT AT CENTER OF DITCH CHECK (OVERFLOW PT.) (INCHES)	SPACING OF DITCH CHECK (FEET)
8.0	12"	10
	18"	20
	24"	25
7.0	12"	15
	18"	20
	24"	30
6.0	12"	15
	18"	25
	24"	35
5.0	12"	20
	18"	30
	24"	40
4.0	12"	25
	18"	35
	24"	50
3.0	12"	35
	18"	50
	24"	65
2.0	12"	50
	18"	75
	24"	100
1.0 & UNDER	12"	100
	24"	150

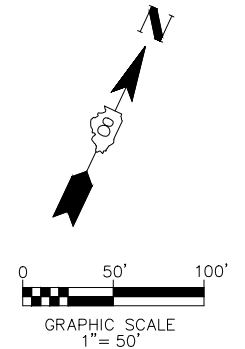

NOTE: ALL ITEMS SHALL BE CONSTRUCTED AS SHOWN ON STANDARD 280001 AND AS DIRECTED BY THE ENGINEER. MAINTENANCE AND CLEANING OF THE EROSION CONTROL ITEMS SHALL BE INCLUDED IN THE RESPECTIVE EROSION CONTROL PAY ITEM.

BY	DATE

BY	DATE

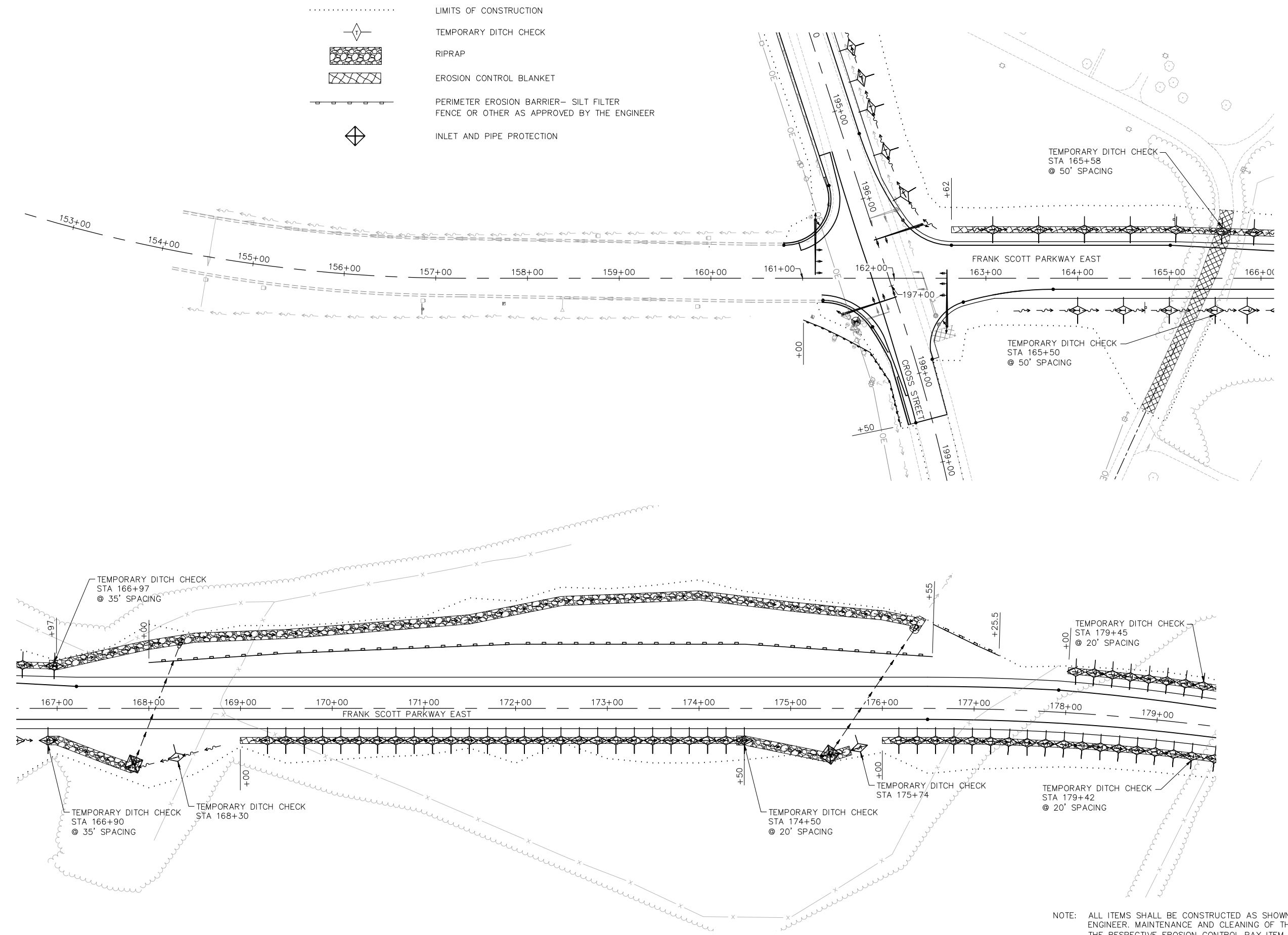

BY	DATE
FINAL SURVEY PLOTTED	
NOTE BOOK TEMPLATE	
	AREAS CHECKED
NO.	

BY	DATE
ORIGINAL SURVEY PLOTTED	
NOTE BOOK TEMPLATE	
	AREAS CHECKED
NO.	

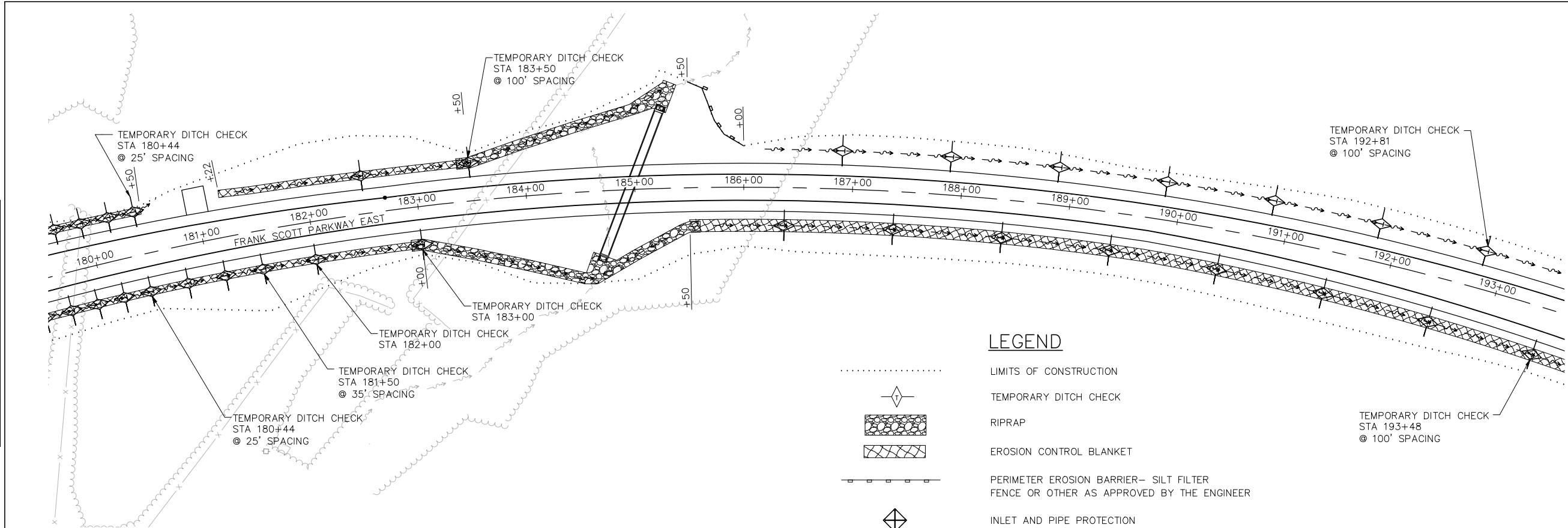

LEGEND

	LIMITS OF CONSTRUCTION
	TEMPORARY DITCH CHECK
	RIPRAP
	EROSION CONTROL BLANKET
	PERIMETER EROSION BARRIER - SILT FILTER FENCE OR OTHER AS APPROVED BY THE ENGINEER
	INLET AND PIPE PROTECTION

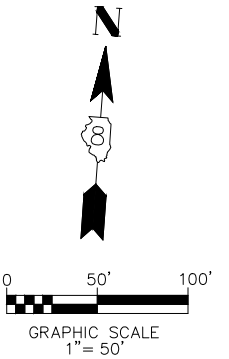

DITCH CHECK SPACING

SLOPE (%)	HEIGHT AT CENTER OF DITCH CHECK (OVERFLOW PT.) (INCHES)	SPACING OF DITCH CHECK (FEET)
6.0	12"	10
	18"	20
	24"	25
7.0	12"	15
	18"	20
	24"	30
8.0	12"	15
	18"	25
	24"	35
9.0	12"	20
	18"	30
	24"	40
10.0	12"	25
	18"	35
	24"	50
11.0	12"	30
	18"	45
	24"	65
12.0	12"	35
	18"	55
	24"	100
13.0	12"	40
	18"	65
	24"	150
14.0	12"	45
	18"	80
	24"	185
15.0	12"	50
	18"	100
	24"	200
16.0	12"	60
	18"	125
	24"	250
17.0	12"	70
	18"	150
	24"	300
18.0	12"	80
	18"	175
	24"	350
19.0	12"	90
	18"	200
	24"	400
20.0	12"	100
	18"	225
	24"	450
21.0	12"	110
	18"	250
	24"	500
22.0	12"	120
	18"	275
	24"	550
23.0	12"	130
	18"	300
	24"	600
24.0	12"	140
	18"	325
	24"	650
25.0	12"	150
	18"	350
	24"	700
26.0	12"	160
	18"	375
	24"	750
27.0	12"	170
	18"	400
	24"	800
28.0	12"	180
	18"	425
	24"	850
29.0	12"	190
	18"	450
	24"	900
30.0	12"	200
	18"	475
	24"	950
31.0	12"	210
	18"	500
	24"	1000
32.0	12"	220
	18"	525
	24"	1050
33.0	12"	230
	18"	550
	24"	1100
34.0	12"	240
	18"	575
	24"	1150
35.0	12"	250
	18"	600
	24"	1200
36.0	12"	260
	18"	625
	24"	1250
37.0	12"	270
	18"	650
	24"	1300
38.0	12"	280
	18"	675
	24"	1350
39.0	12"	290
	18"	700
	24"	1400
40.0	12"	300
	18"	725
	24"	1450
41.0	12"	310
	18"	750
	24"	1500
42.0	12"	320
	18"	775
	24"	1550
43.0	12"	330
	18"	800
	24"	1600
44.0	12"	340
	18"	825
	24"	1650
45.0	12"	350
	18"	850
	24"	1700
46.0	12"	360
	18"	875
	24"	1750
47.0	12"	370
	18"	900
	24"	1800
48.0	12"	380
	18"	925
	24"	1850
49.0	12"	390
	18"	950
	24"	1900
50.0	12"	400
	18"	975
	24"	1950

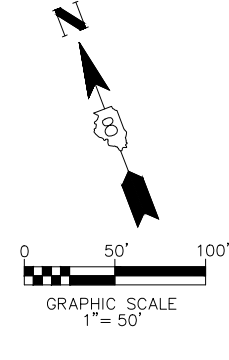
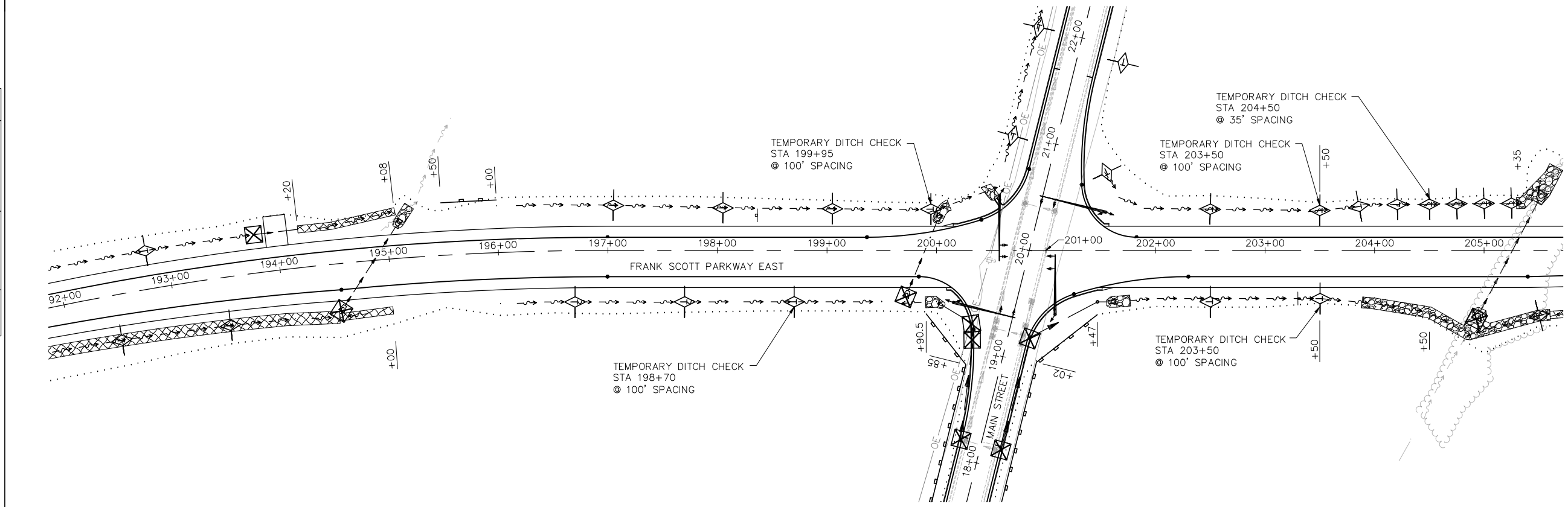

F.A.U. RT.	SECTION	COUNTY	TOTAL SHEETS	SHEET NO.
9330	95-00301-03-PV	ST. CLAIR	166	57
STA. 205+00	TO STA. 231+00			
FED. ROAD DIST. NO.	ILLINOIS	FED. AID PROJECT		
EROSION CONTROL PLAN				
CONTRACT NO.: 97372				

BY	DATE
FINAL SURVEY PLOTTED	
NOTE BOOK TEMPLATE	
AREAS CHECKED	
NO.	

BY	DATE
ORIGINAL SURVEY PLOTTED	
NOTE BOOK TEMPLATE	
AREAS CHECKED	
NO.	

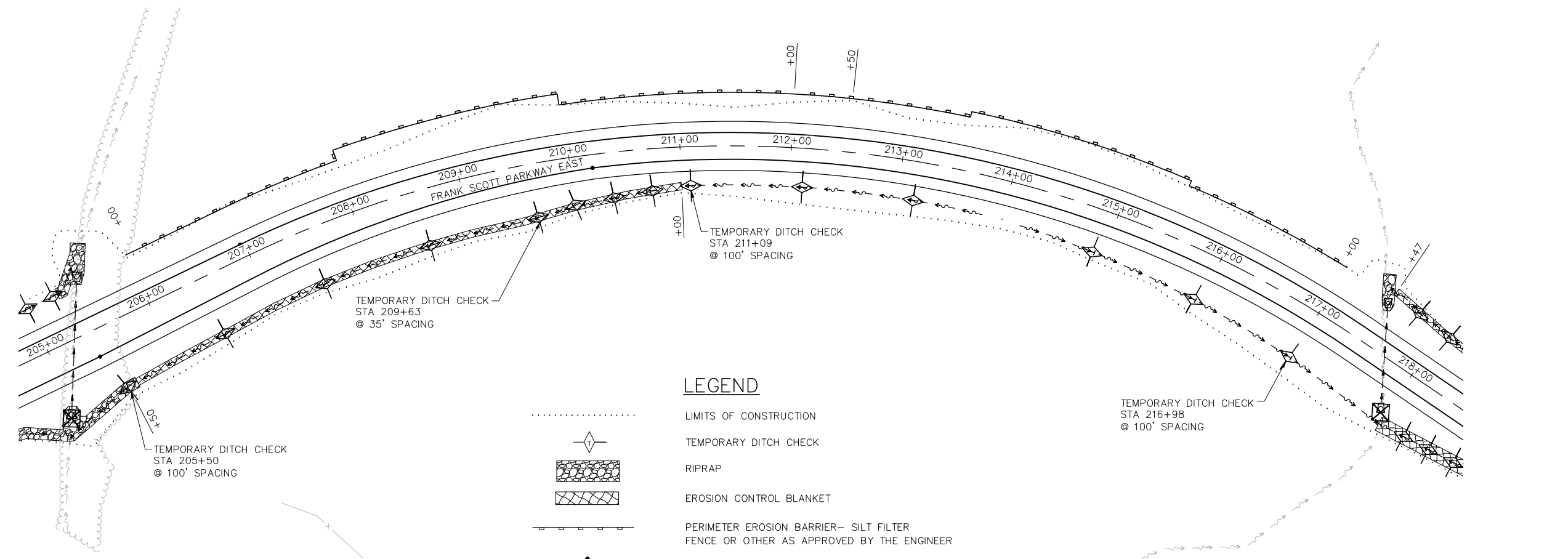

LEGEND

- LIMITS OF CONSTRUCTION
- TEMPORARY DITCH CHECK
- RIPRAP
- EROSION CONTROL BLANKET
- PERIMETER EROSION BARRIER- SILT FILTER FENCE OR OTHER AS APPROVED BY THE ENGINEER
- INLET AND PIPE PROTECTION

DITCH CHECK SPACING

SLOPE (%)	HEIGHT AT CENTER OF DITCH CHECK (OVERFLOW PT) (INCHES)	SPACING OF DITCH CHECK (FEET)
8.0	12"	10
	18"	20
	24"	25
7.0	12"	15
	18"	20
6.0	12"	15
	18"	20
	24"	25
5.0	12"	20
	18"	30
	24"	40
4.0	12"	25
	18"	35
	24"	50
3.0	12"	35
	18"	50
	24"	75
2.0	12"	50
	18"	75
1.0	12"	100
	18"	150
3/4 UNDER	18"	150
	24"	195

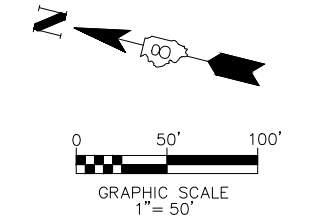
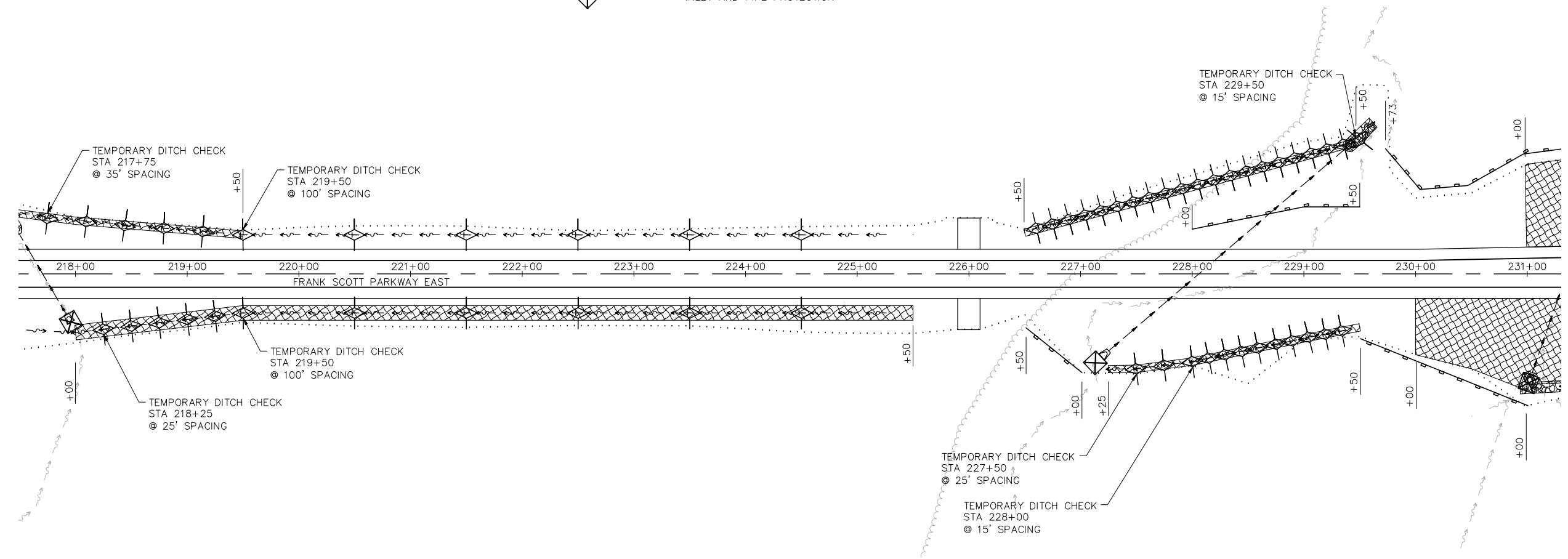

F.A.U. RT.	SECTION	COUNTY	TOTAL SHEETS	SHEET NO.
9330	95-00301-03-PV	ST. CLAIR	166	58
STA. 231+00 TO STA. 252+00				
FED. ROAD DIST. NO.		ILLINOIS	FED. AID PROJECT	
EROSION CONTROL PLAN				
CONTRACT NO.: 97372				

LEGEND

- LIMITS OF CONSTRUCTION
- ◇ TEMPORARY DITCH CHECK
- ▨ RIPRAP
- ▩ EROSION CONTROL BLANKET
- ▬ PERIMETER EROSION BARRIER- SILT FILTER FENCE OR OTHER AS APPROVED BY THE ENGINEER
- ◇ INLET AND PIPE PROTECTION

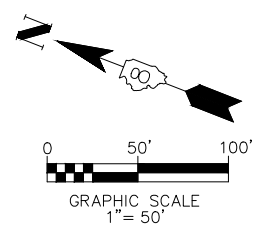

DITCH CHECK SPACING

SLOPE (%)	HEIGHT AT CENTER OF DITCH CHECK (OVERFLOW PT) (INCHES)	SPACING OF DITCH CHECK (FEET)
8.0	12"	10
	18"	20
	24"	25
7.0	12"	15
	18"	20
	24"	30
6.0	12"	15
	18"	25
	24"	35
5.0	12"	20
	18"	30
	24"	40
4.0	12"	25
	18"	35
	24"	50
3.0	12"	35
	18"	50
	24"	65
2.0	12"	50
	18"	75
	24"	100
1.0	12"	100
	18"	150
	24"	195
& UNDER	18"	150
	24"	195

BY	DATE
FINAL SURVEY PLOTTED	
NOTE BOOK TEMPLATE	
AREAS CHECKED	
NO.	

BY	DATE
ORIGINAL SURVEY PLOTTED	
NOTE BOOK TEMPLATE	
AREAS CHECKED	
NO.	

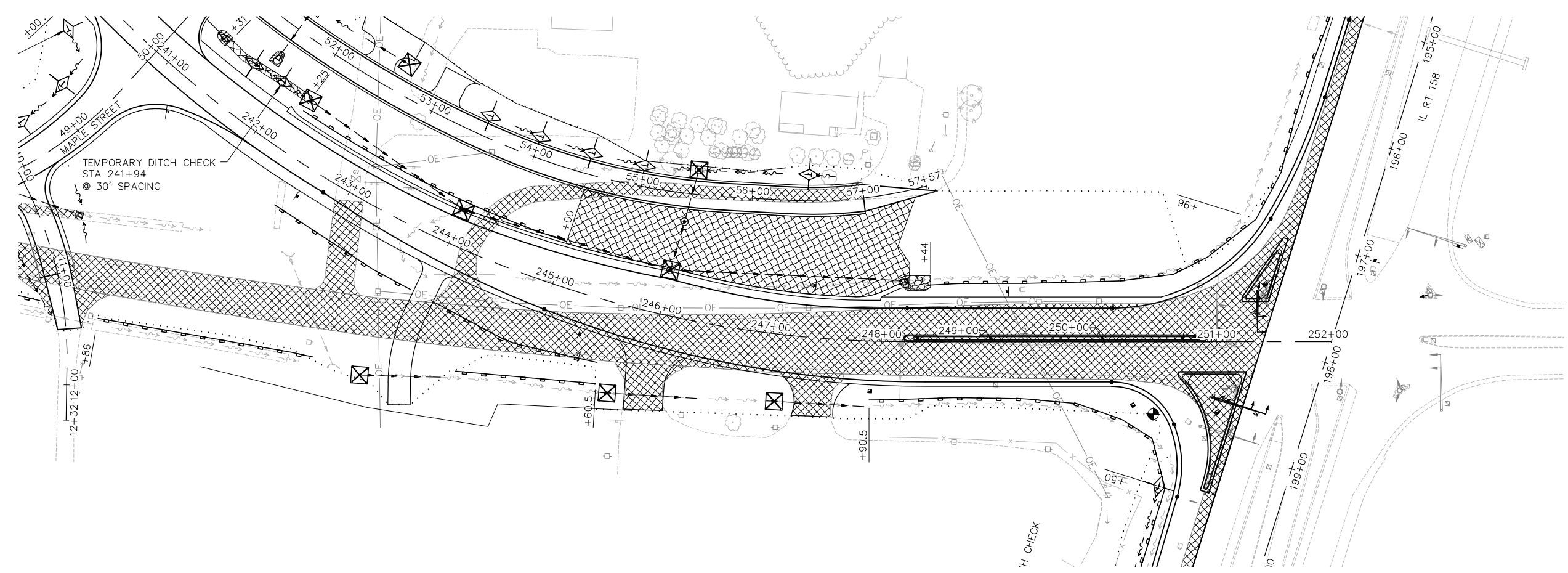
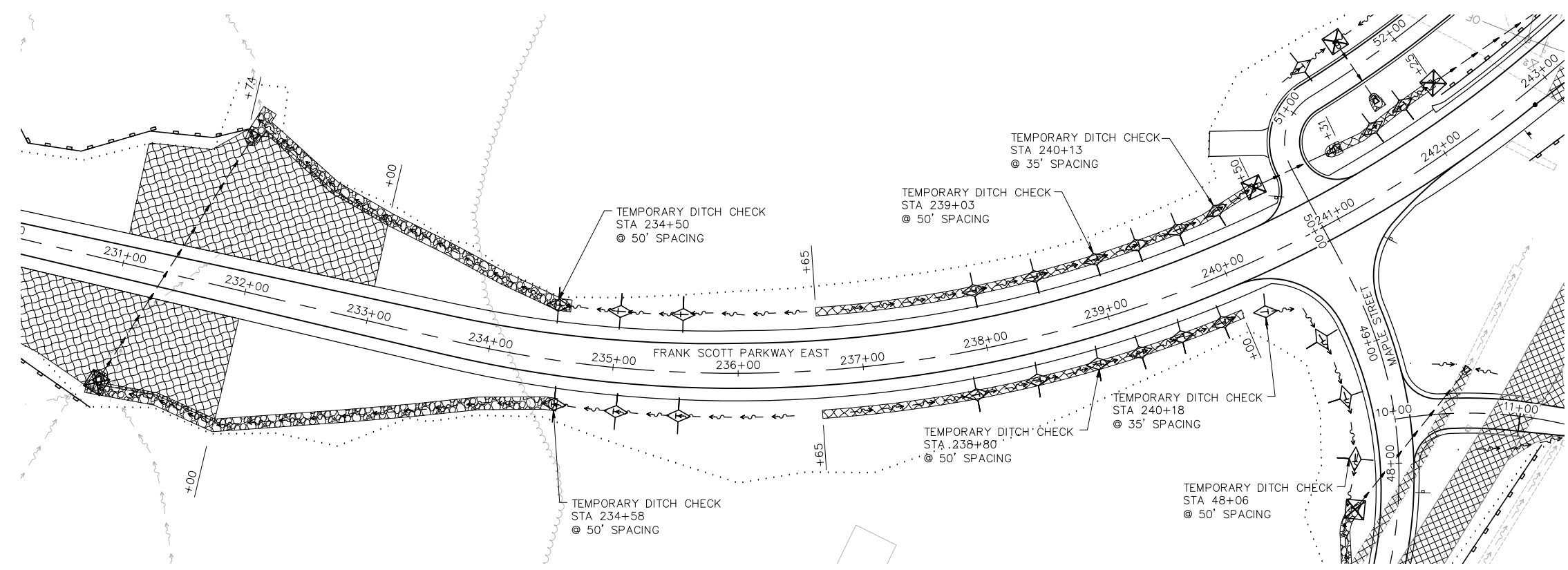

F.A.U. RTE.	SECTION	COUNTY	TOTAL SHEETS	SHEET NO.
9330	95-00301-03-PV	ST. CLAIR	166	59
STA. 187+00 TO STA. 200+00				
FED. ROAD DIST. NO.		ILLINOIS	FED. AID PROJECT	
EROSION CONTROL PLAN				

CONTRACT NO.: 97372

BY	DATE
FINAL SURVEYED	
PLOTTED	
NOTE BOOK	
TEMPLATE	
AREAS	
CHECKED	
NO.	

BY	DATE
ORIGINAL SURVEYED	
PLOTTED	
NOTE BOOK	
TEMPLATE	
AREAS	
CHECKED	
NO.	

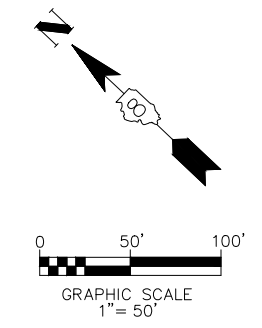
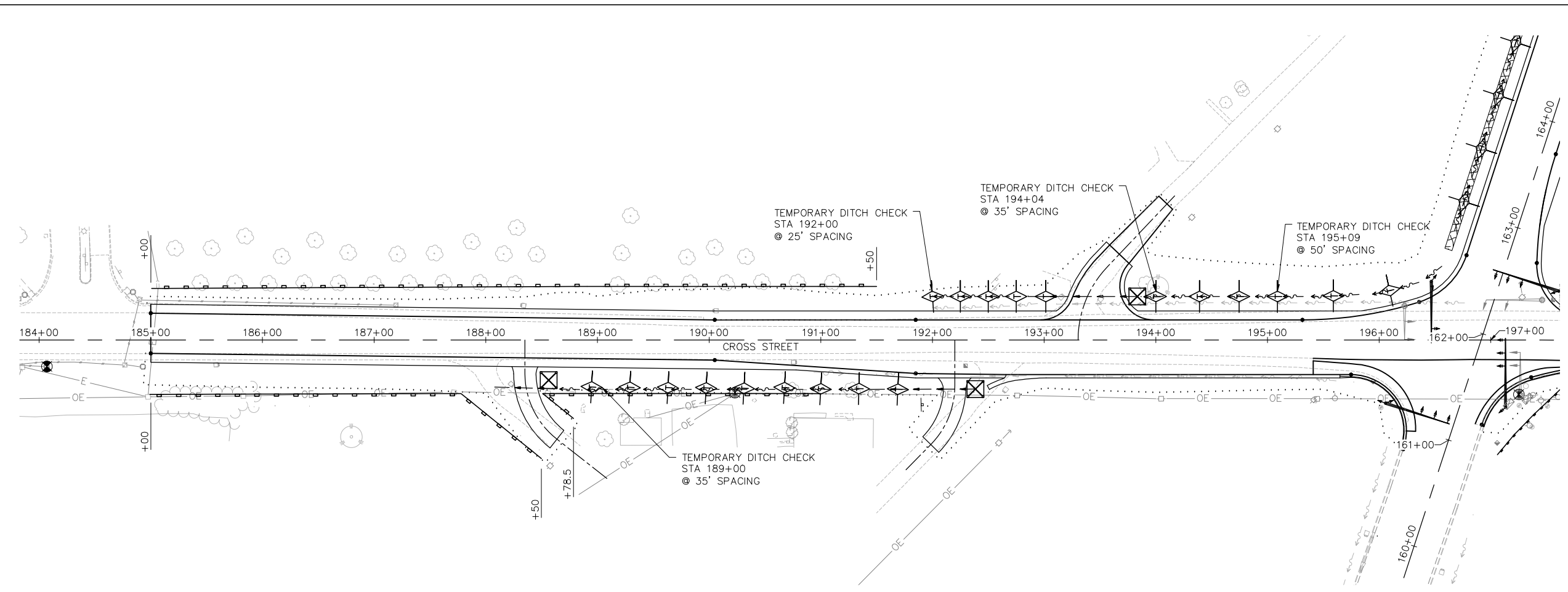

DITCH CHECK SPACING

SLOPE (%)	HEIGHT AT CENTER OF DITCH CHECK (OVERFLOW PT) (INCHES)	SPACING OF DITCH CHECK (FEET)
8.0	12"	10
	18"	20
	24"	25
7.0	12"	15
	18"	20
	24"	30
6.0	12"	15
	18"	25
	24"	35
5.0	12"	20
	18"	30
	24"	40
4.0	12"	25
	18"	35
	24"	50
3.0	12"	35
	18"	50
	24"	85
2.0	12"	50
	18"	75
	24"	100
1.0	12"	100
	24"	150
& UNDER	18"	150
	24"	185

LEGEND

- LIMITS OF CONSTRUCTION
- ◆ TEMPORARY DITCH CHECK
- ▨ RIPRAP
- ▩ EROSION CONTROL BLANKET
- PERIMETER EROSION BARRIER— SILT FILTER FENCE OR OTHER AS APPROVED BY THE ENGINEER
- ◆ INLET AND PIPE PROTECTION



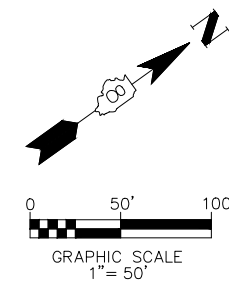

F.A.U. RTE.	SECTION	COUNTY	TOTAL SHEETS	SHEET NO.
9330	95-00301-03-PV	ST. CLAIR	166	60
STA. 9+00 TO STA. 33+00				
FED. ROAD DIST. NO.	ILLINOIS	FED. AID PROJECT		
EROSION CONTROL PLAN				
CONTRACT NO.: 97372				

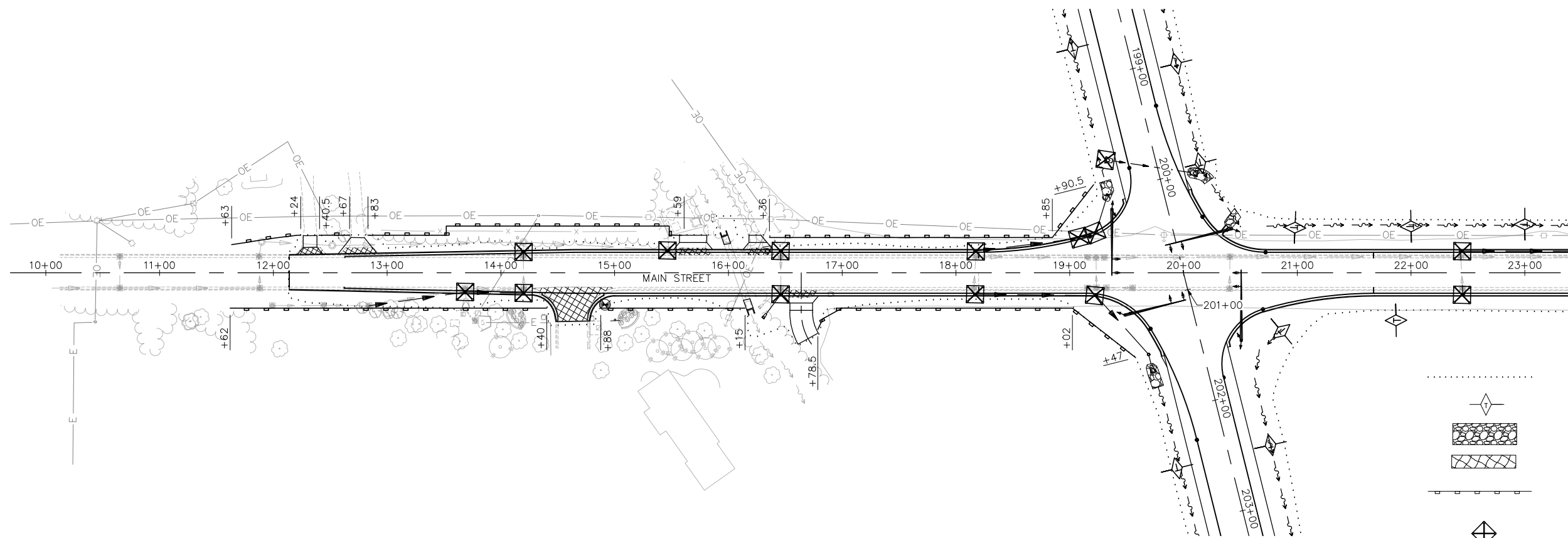

BY	DATE
FINAL SURVEYED	
SURVEY PLOTTED	
NOTE BOOK TEMPLATE	
AREAS CHECKED	
NO.	

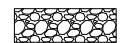
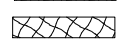
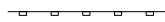

LEGEND

-  LIMITS OF CONSTRUCTION
-  TEMPORARY DITCH CHECK
-  RIPRAP
-  EROSION CONTROL BLANKET
-  PERIMETER EROSION BARRIER- SILT FILTER FENCE OR OTHER AS APPROVED BY THE ENGINEER
-  INLET AND PIPE PROTECTION

BY	DATE
ORIGINAL SURVEYED	
SURVEY PLOTTED	
NOTE BOOK TEMPLATE	
AREAS CHECKED	
NO.	

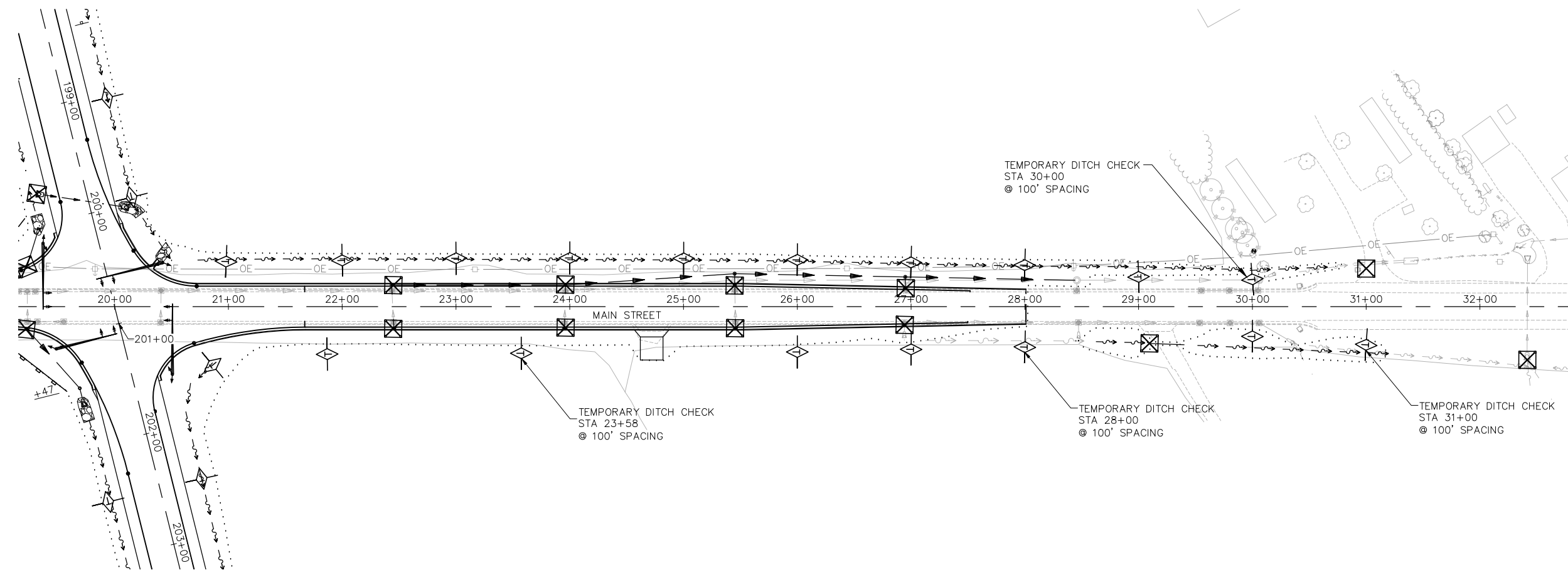

DITCH CHECK SPACING

SLOPE (%)	HEIGHT AT CENTER OF DITCH CHECK (OVERFLOW PT) (INCHES)	SPACING OF DITCH CHECK (FEET)
8.0	12"	10
	18"	20
	24"	25
7.0	12"	15
	18"	20
	24"	30
6.0	12"	15
	18"	25
	24"	35
5.0	12"	20
	18"	30
	24"	40
4.0	12"	25
	18"	35
	24"	50
3.0	12"	35
	18"	50
	24"	65
2.0	12"	50
	18"	75
	24"	100
1.0 & UNDER	12"	100
	18"	150
	24"	195

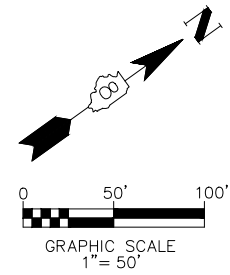



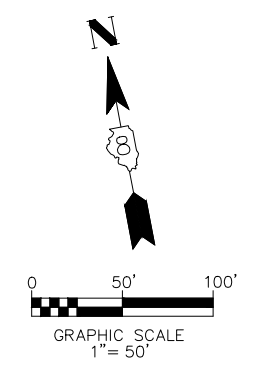

F.A.U. RTE.	SECTION	COUNTY	TOTAL SHEETS	SHEET NO.
9330	95-00301-03-PV	ST. CLAIR	166	61
STA. 46+00 TO STA. 57+00				
FED. ROAD DIST. NO.	ILLINOIS	FED. AID PROJECT		
EROSION CONTROL PLAN				
CONTRACT NO.: 97372				

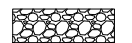
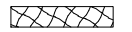

SLOPE (%)	HEIGHT AT CENTER OF DITCH CHECK (OVERFLOW PT) (INCHES)	SPACING OF DITCH CHECK (FEET)
8.0	12"	10
	18"	20
	24"	25
7.0	12"	15
	18"	20
	24"	30
6.0	12"	15
	18"	25
	24"	35
5.0	12"	20
	18"	30
	24"	40
4.0	12"	25
	18"	35
	24"	50
3.0	12"	35
	18"	50
	24"	65
2.0	12"	50
	18"	75
	24"	100
1.0	12"	100
	18"	150
& UNDER	18"	150
	24"	195

LEGEND

-  LIMITS OF CONSTRUCTION
-  TEMPORARY DITCH CHECK
-  RIPRAP
-  EROSION CONTROL BLANKET
-  PERIMETER EROSION BARRIER- SILT FILTER FENCE OR OTHER AS APPROVED BY THE ENGINEER
-  INLET AND PIPE PROTECTION

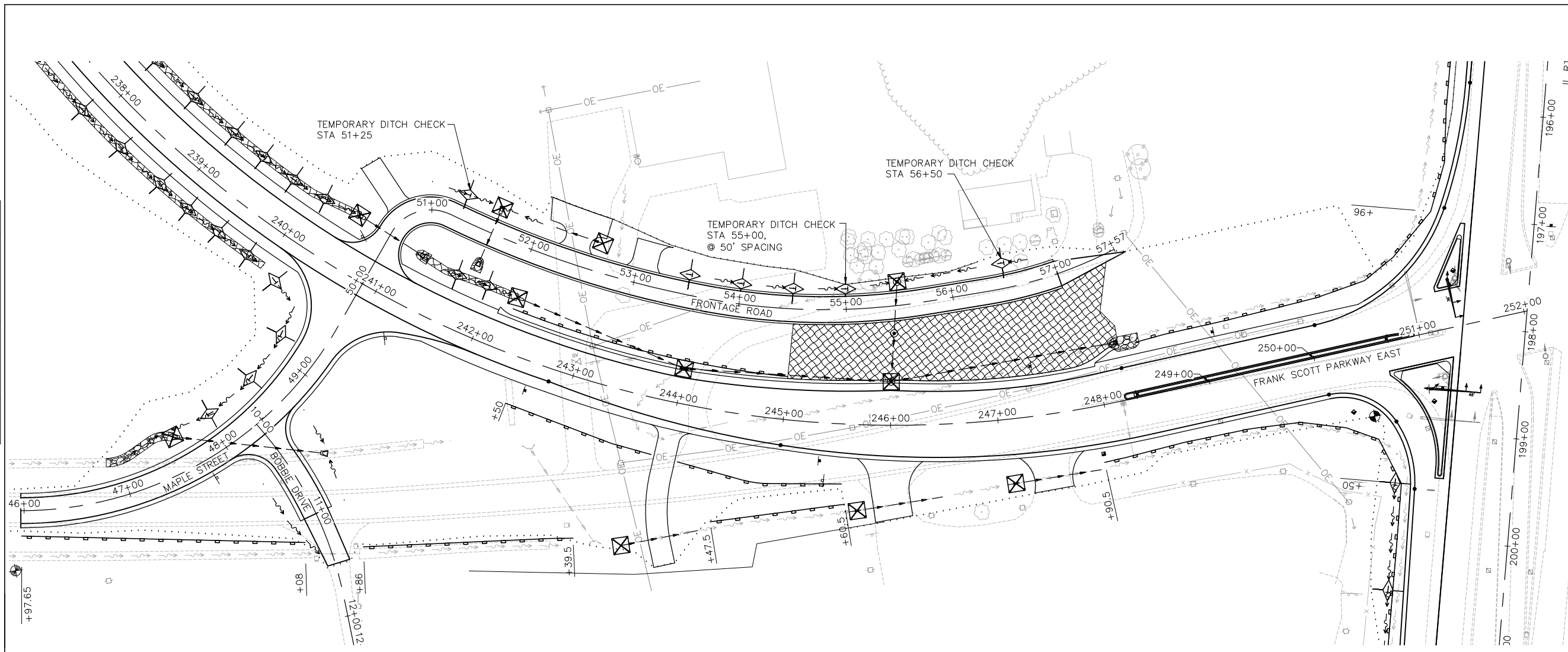

BY	DATE
FINAL SURVEY PLOTTED	
NOTE BOOK TEMPLATE	
AREAS CHECKED	
NO.	

BY	DATE
ORIGINAL SURVEY PLOTTED	
NOTE BOOK TEMPLATE	
AREAS CHECKED	
NO.	

F.A.U. RT.	SECTION	COUNTY	TOTAL SHEETS	SHEET NO.
9330	95-00301-03-PV	ST. CLAIR	166	62
STA. 192+00 TO STA. 214+00				
FED. ROAD DIST. NO.		ILLINOIS	FED. AID PROJECT	
EROSION CONTROL PLAN				
CONTRACT NO.: 97372				

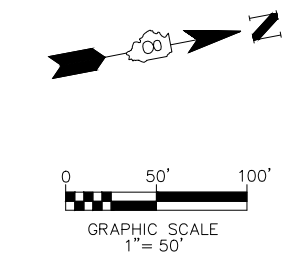
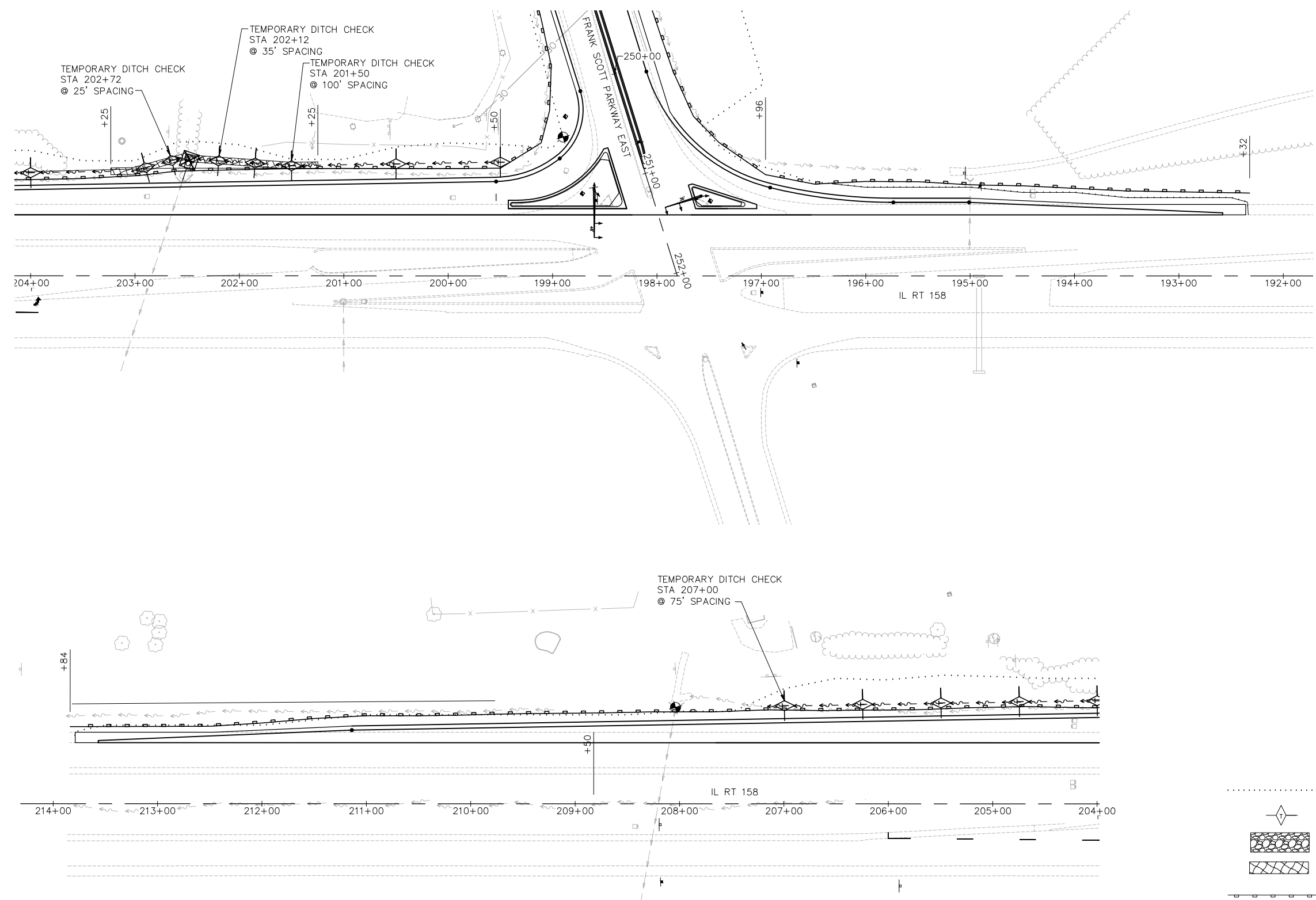

DITCH CHECK SPACING		
SLOPE (%)	HEIGHT AT CENTER OF DITCH CHECK (OVERFLOW PT?) (INCHES)	SPACING OF DITCH CHECK (FEET)
8.0	12"	10
	18"	20
	24"	25
7.0	12"	15
	18"	20
6.0	12"	15
	18"	25
	24"	35
5.0	12"	20
	18"	30
4.0	12"	25
	18"	35
	24"	50
3.0	12"	35
	18"	50
2.0	12"	50
	18"	75
1.0	12"	100
	18"	150
& UNDER	12"	150
	18"	195

LEGEND	
	LIMITS OF CONSTRUCTION
	TEMPORARY DITCH CHECK
	RIPRAP
	EROSION CONTROL BLANKET
	PERIMETER EROSION BARRIER- SILT FILTER FENCE OR OTHER AS APPROVED BY THE ENGINEER
	INLET AND PIPE PROTECTION

BY	DATE
FINAL SURVEY PLOTTED	
NOTE BOOK TEMPLATE	
AREAS CHECKED	
NO.	

BY	DATE
ORIGINAL SURVEY PLOTTED	
NOTE BOOK TEMPLATE	
AREAS CHECKED	
NO.	

F.A.U. RTE.	SECTION	COUNTY	TOTAL SHEETS	SHEET NO.
9330	95-00301-03-PV	ST. CLAIR	166	63
	STA. 155+00 TO STA. 186+00			
FED. ROAD DIST. NO.		ILLINOIS	FED. AID PROJECT	
R.O.W. & T.C.E.			CONTRACT NO.: 97372	

N/F METRO EAST SERVICES, INC.
04-32.0-300-038
DOC. A02480490

BY	DATE

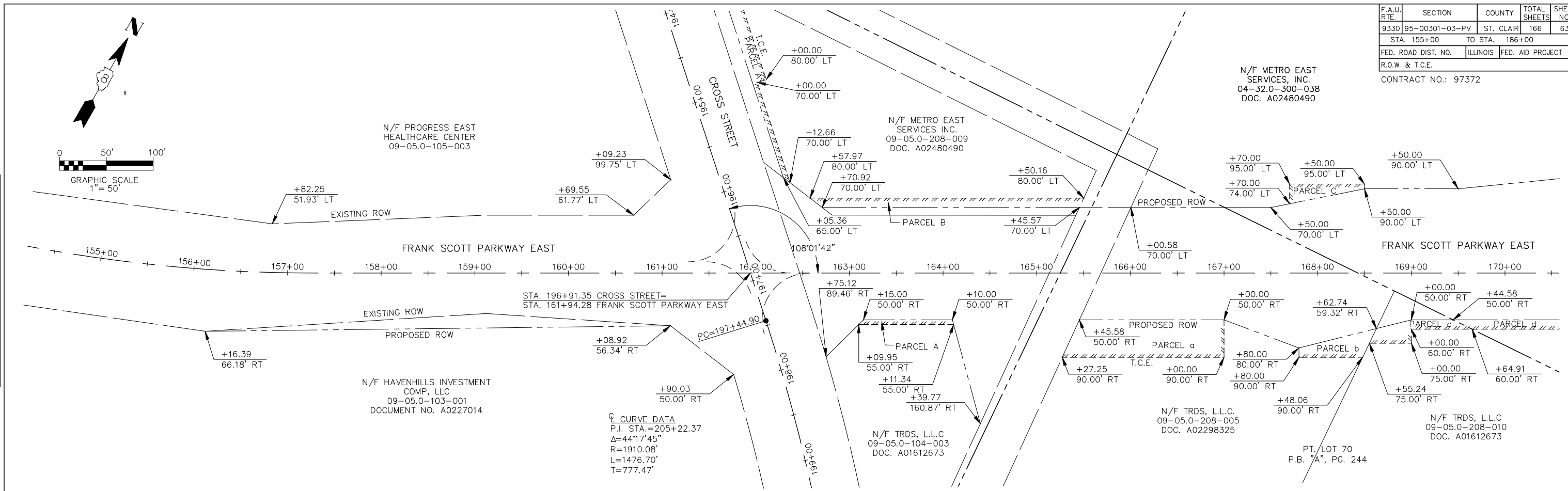
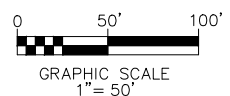

BY	DATE

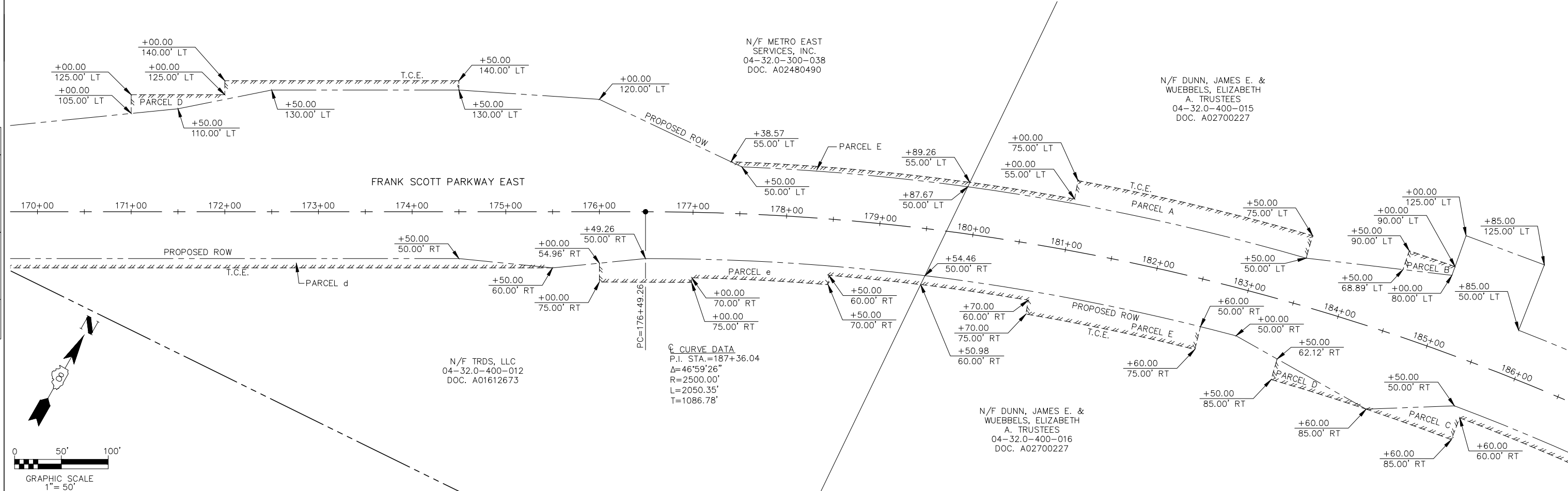
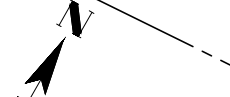

FRANK SCOTT PARKWAY EAST

F.A.U. RTE.	SECTION	COUNTY	TOTAL SHEETS	SHEET NO.
9330	95-00301-03-PV	ST. CLAIR	166	64
	STA. 184+00	TO STA.	215+00	
FED. ROAD DIST. NO.	ILLINOIS	FED. AID PROJECT		
R.O.W. & T.C.E.				
CONTRACT NO.: 97372				

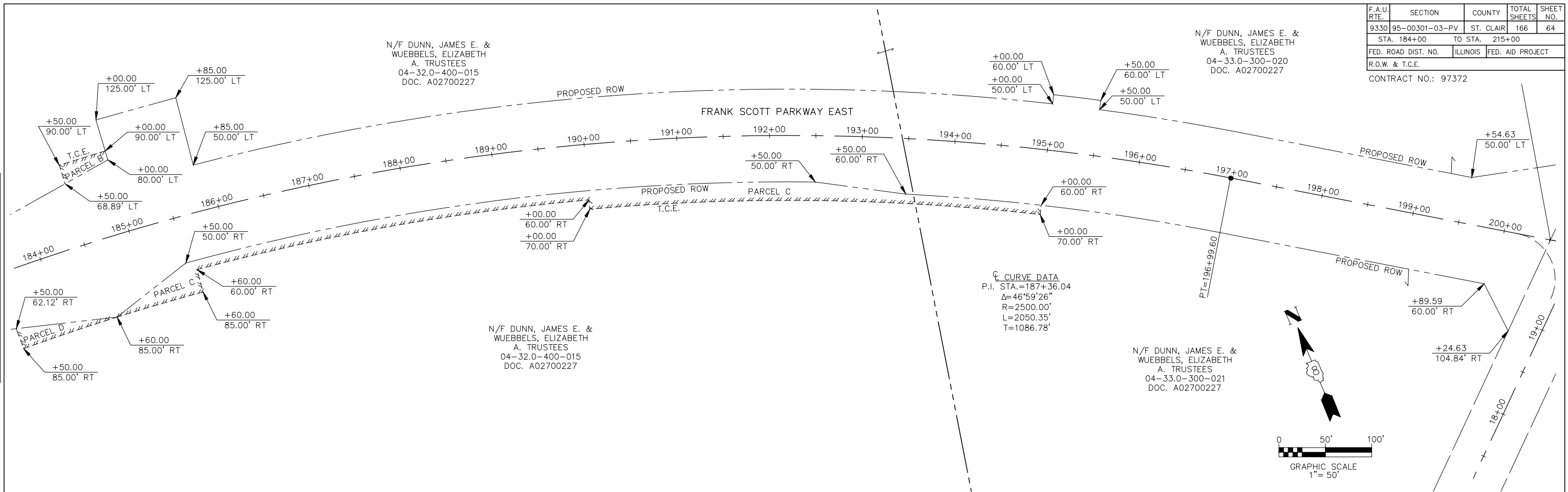

BY	DATE
ORIGINAL SURVEY PLOTTED	
NOTE BOOK TEMPLATE	
AREAS CHECKED	
NO.	

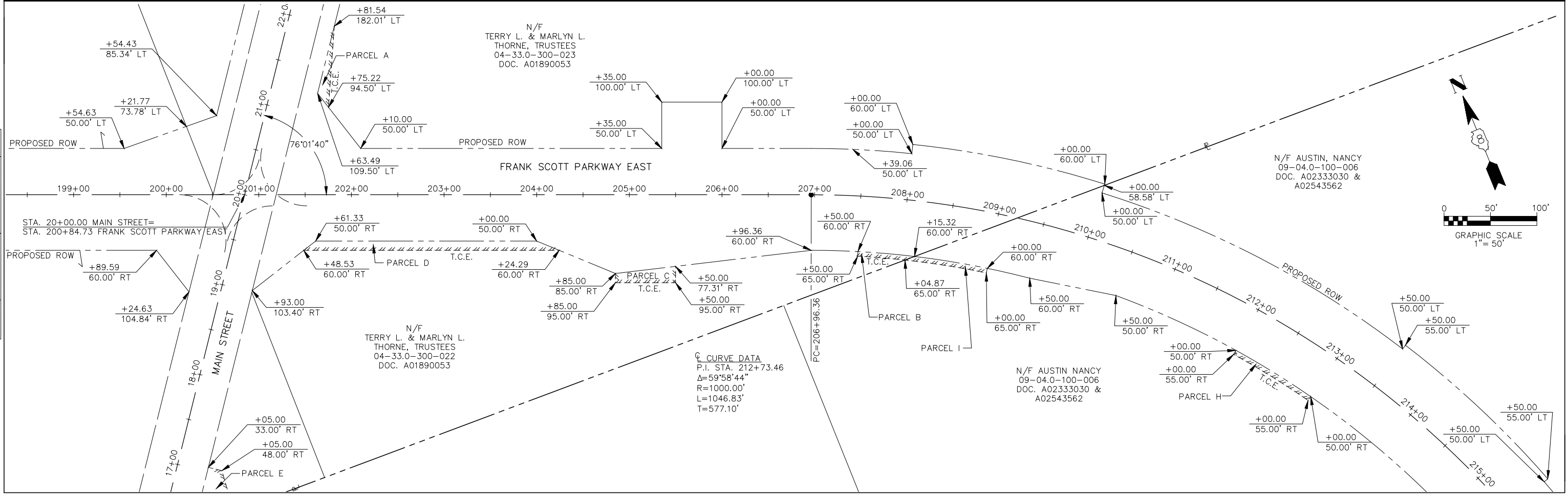

BY	DATE
ORIGINAL SURVEY PLOTTED	
NOTE BOOK TEMPLATE	
AREAS CHECKED	
NO.	

F.A.U. RTE.	SECTION	COUNTY	TOTAL SHEETS	SHEET NO.
9330	95-00301-03-PV	ST. CLAIR	166	65
STA. 213+00 TO STA. 240+00				
FED. ROAD DIST. NO.		ILLINOIS	FED. AID PROJECT	
R.O.W. & T.C.E.				

CONTRACT NO.: 97372

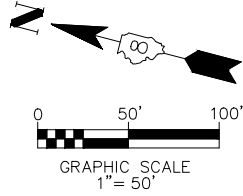

N/F AUSTIN, NANCY
09-04.0-100-006
DOC. A02333030 &
A02543562

BY	DATE

DATE	BY

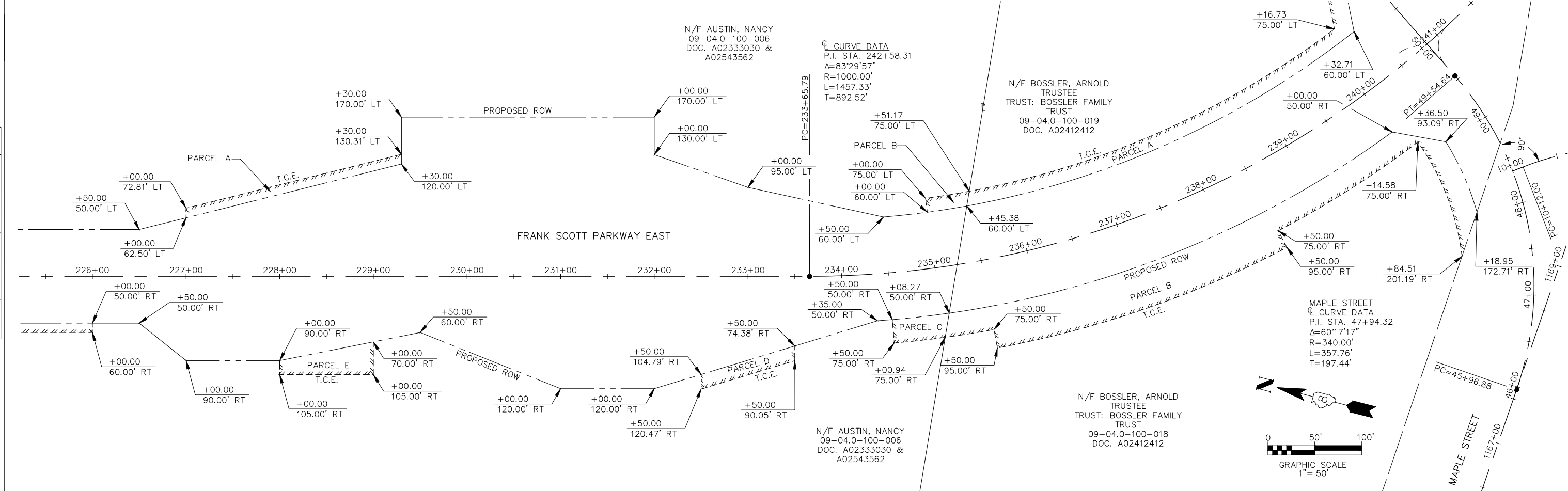
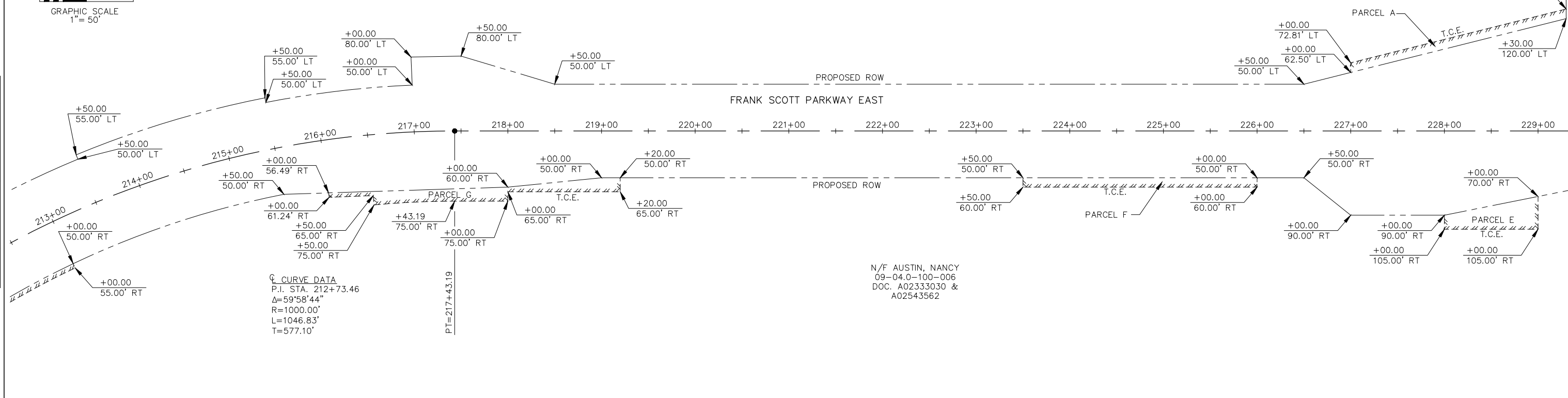

FRANK SCOTT PARKWAY EAST

F.A.U. RTE.	SECTION	COUNTY	TOTAL SHEETS	SHEET NO.
9330	95-00301-03-PV	ST. CLAIR	166	66
STA. 236+00 TO STA. 252+00				
FED. ROAD DIST. NO.		ILLINOIS	FED. AID PROJECT	
R.O.W. & T.C.E.				

CONTRACT NO.: 97372

BY	DATE

BY	DATE

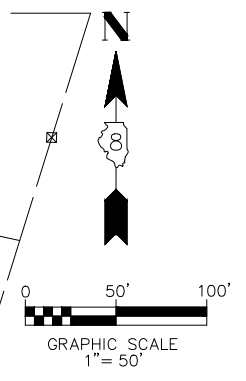
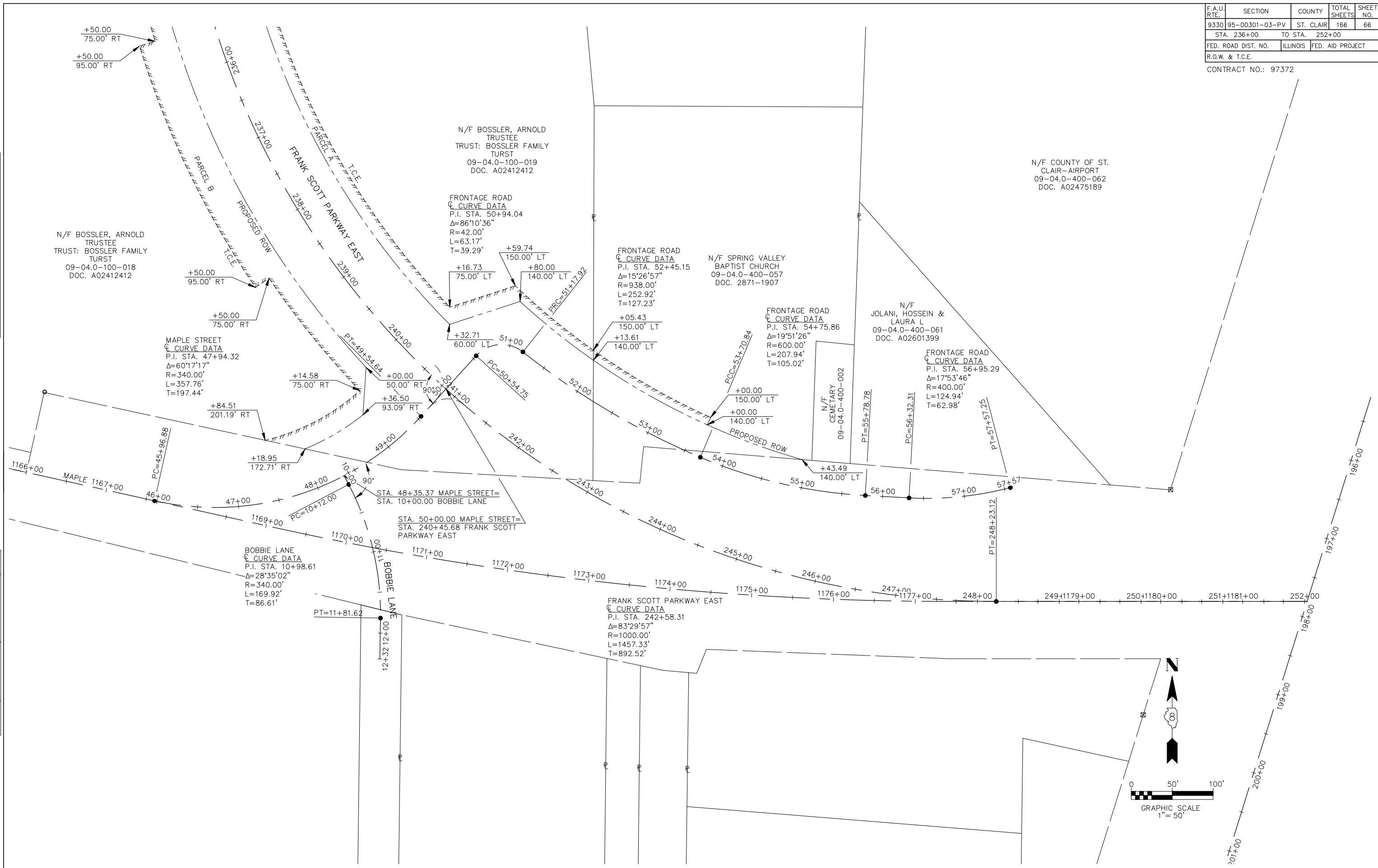

F.A.U. RTE.	SECTION	COUNTY	TOTAL SHEETS	SHEET NO.
9330	95-00301-03-PV	ST. CLAIR	166	67
STA.	TO STA.			
FED. ROAD DIST. NO.		ILLINOIS	FED. AID PROJECT	
R.O.W. & T.C.E.				

CONTRACT NO.: 97372

BY	DATE

DATE	BY

FINAL SURVEY PLOTTED	
NOTE BOOK TEMPLATE	
AREAS CHECKED	
NO.	

ORIGINAL SURVEY PLOTTED	
NOTE BOOK TEMPLATE	
AREAS CHECKED	
NO.	

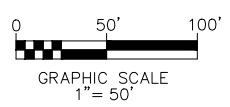
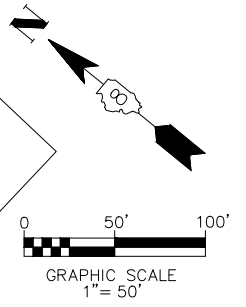
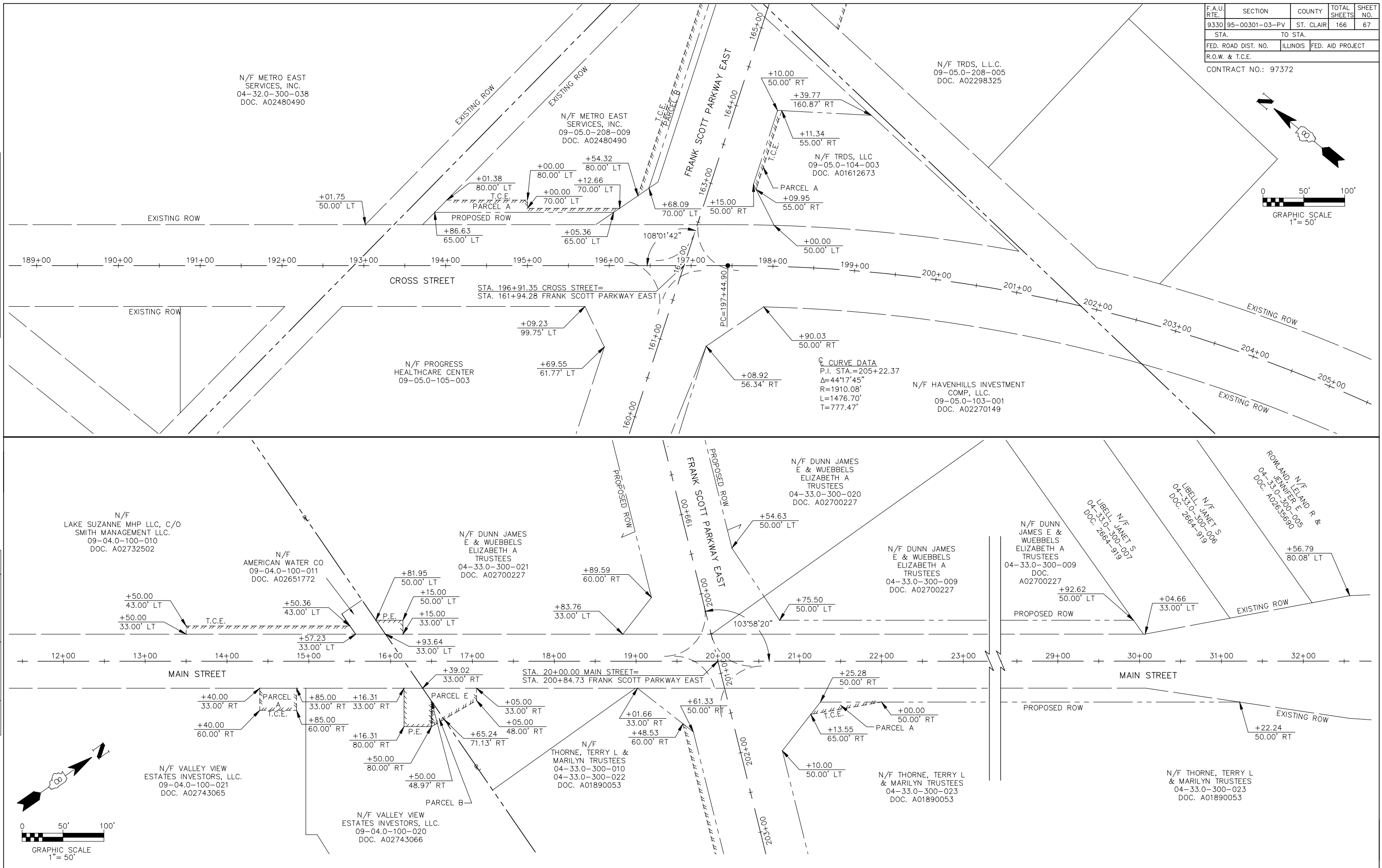

F.A.U. RTE.	SECTION	COUNTY	TOTAL SHEETS	SHEET NO.
9330	95-00301-03-PV	ST. CLAIR	166	68
STA. TO STA.				
FED. ROAD DIST. NO.		ILLINOIS FED. AID PROJECT		
INTERSECTION DETAILS				

CONTRACT NO.: 97372

164+94.67, 266.10' LT
350.00' R (EP)

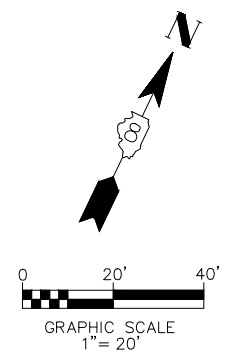

FRANK SCOTT PARKWAY EAST & CROSS STREET INTERSECTION DETAIL

SCALE: 1" = 20'

BY	DATE

BY	DATE

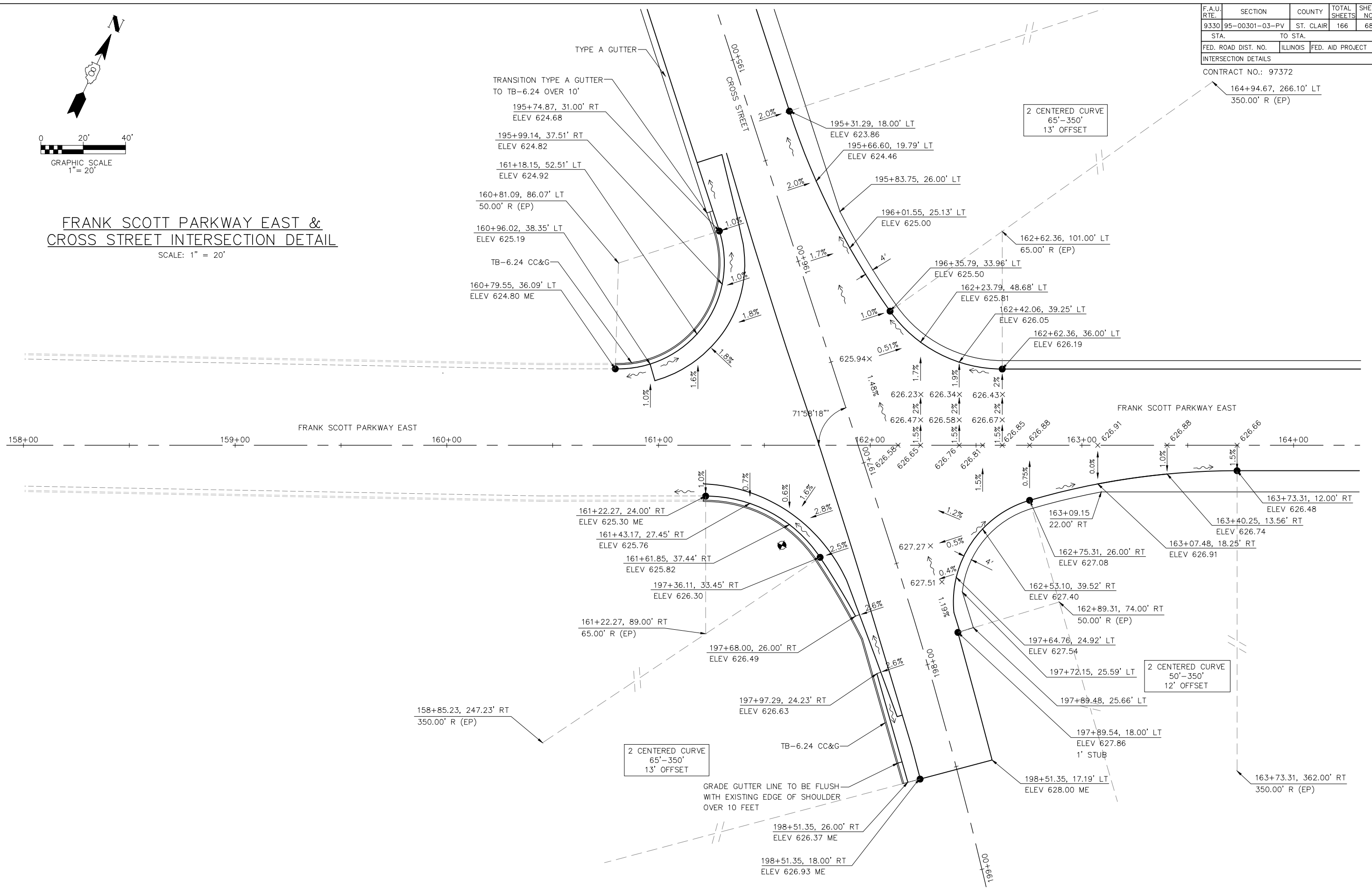

F.A.U. RTE.	SECTION	COUNTY	TOTAL SHEETS	SHEET NO.
9330	95-00301-03-PV	ST. CLAIR	166	69
STA. TO STA.				
FED. ROAD DIST. NO.		ILLINOIS FED. AID PROJECT		
INTERSECTION DETAILS				
CONTRACT NO.: 97372				

FRANK SCOTT PARKWAY EAST & MAIN STREET INTERSECTION DETAIL

SCALE: 1" = 20'

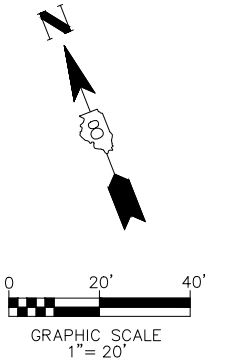

BY	DATE

BY	DATE

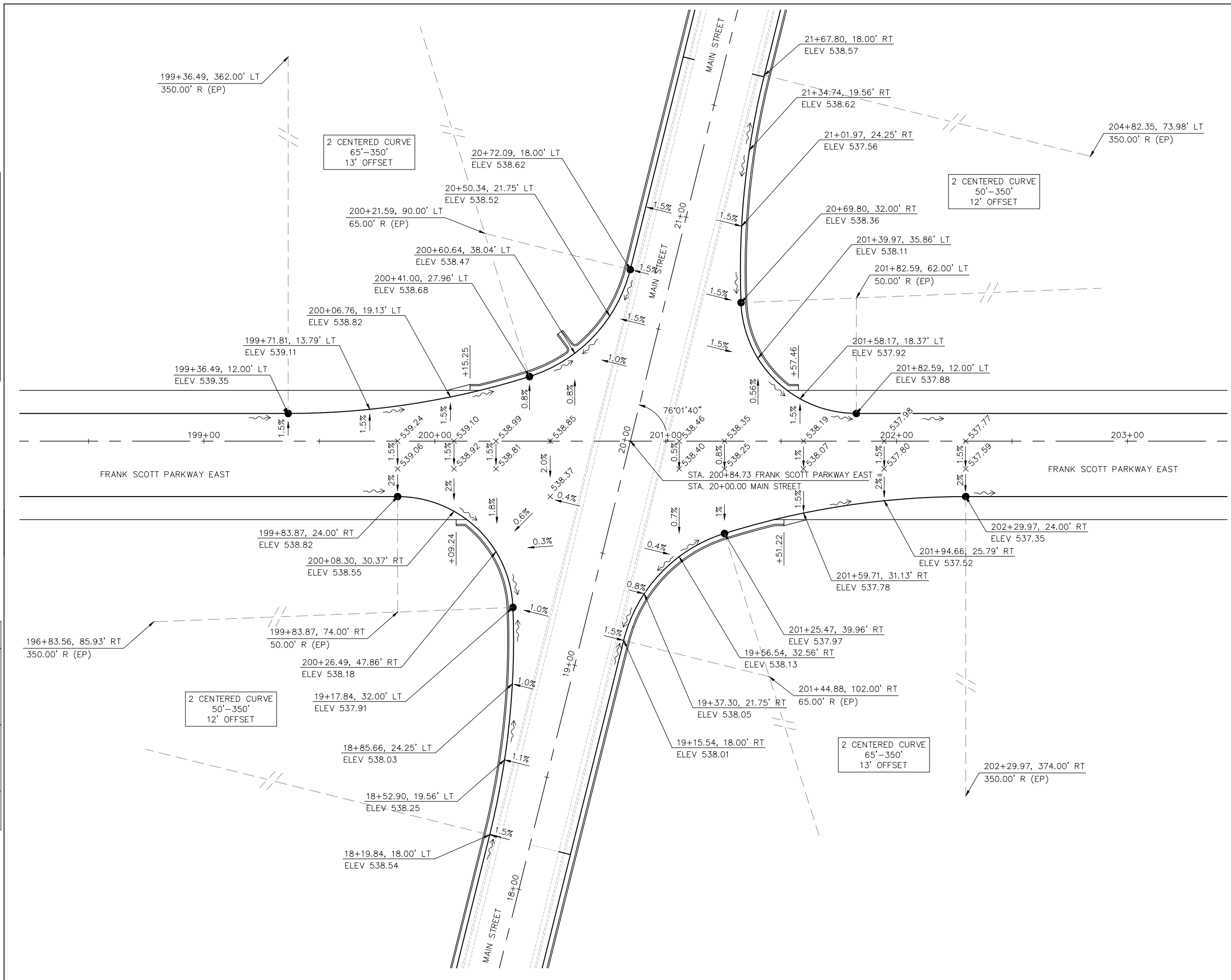

F.A.U. RTE.	SECTION	COUNTY	TOTAL SHEETS	SHEET NO.
9330	95-00301-03-PV	ST. CLAIR	166	70
STA.		TO STA.		
FED. ROAD DIST. NO.		ILLINOIS	FED. AID PROJECT	
INTERSECTION DETAILS				

CONTRACT NO.: 97372

FRANK SCOTT PARKWAY EAST & MAPLE STREET INTERSECTION DETAIL

SCALE: 1" = 20'

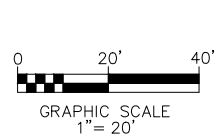

PROPOSED CURVE C7
 PI STA. 50+94.04
 $\Delta = 86^{\circ}10'36''$
 $R = 42.00'$
 $T = 39.29'$
 $L = 63.17'$
 $E = 15.51'$
 $e = \text{NONE}$
 $PC = 50+54.75$
 $PT = 51+17.92$

PROPOSED CURVE C5
 PI STA. 47+94.32
 $\Delta = 60^{\circ}17'17''$
 $R = 340.00'$
 $T = 197.44'$
 $L = 357.76'$
 $E = 53.17'$
 $e = \text{NONE}$
 $PC = 45+96.88$
 $PT = 49+54.64$

2 CENTERED CURVE
 65'-300'
 9' OFFSET

2 CENTERED CURVE
 65'-300'
 9' OFFSET

PROPOSED CURVE C6
 PI STA. 10+98.61
 $\Delta = 28^{\circ}35'02''$
 $R = 340.00'$
 $T = 86.61'$
 $L = 169.62'$
 $E = 10.86'$
 $e = \text{NONE}$
 $PC = 10+12.00$
 $PT = 11+81.62$

FULL DEPTH HMA
 PAVEMENT TRANSITION
 (SEE TYPICAL SECTIONS)

BY	DATE

BY	DATE

F.A.U. RTE.	SECTION	COUNTY	TOTAL SHEETS	SHEET NO.
9330	95-00301-03-PV	ST. CLAIR	166	71
STA.		TO STA.		
FED. ROAD DIST. NO.		ILLINOIS	FED. AID PROJECT	
INTERSECTION DETAILS				
CONTRACT NO.: 97372				

FINAL SURVEY	SURVEYED	DATE
NOTE BOOK	PLOTTED	
NO.	TEMPLATE	
	AREAS	
	CHECKED	

ORIGINAL SURVEY	SURVEYED	DATE
NOTE BOOK	PLOTTED	
NO.	TEMPLATE	
	AREAS	
	CHECKED	

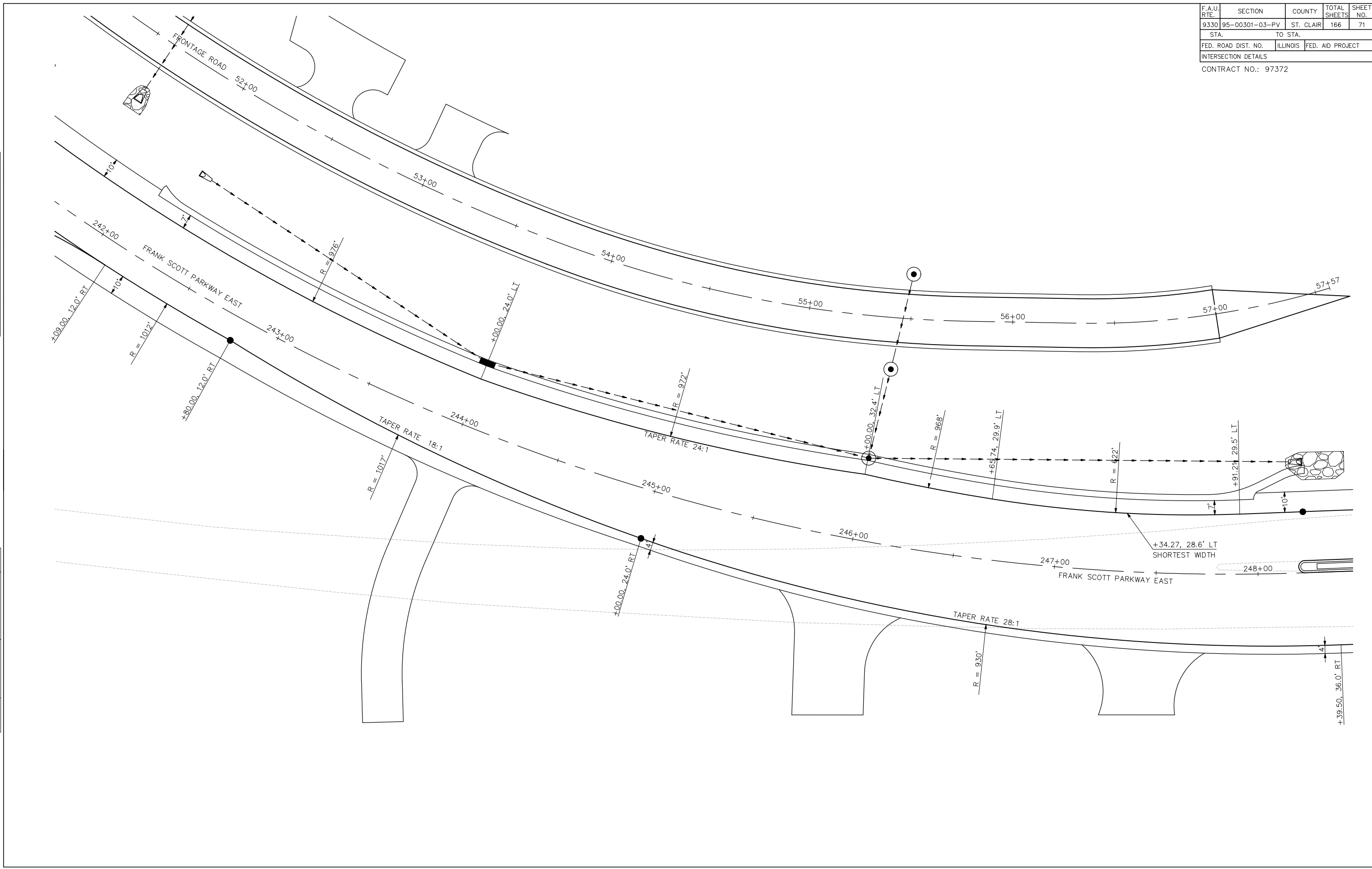

F.A.U. RTE.	SECTION	COUNTY	TOTAL SHEETS	SHEET NO.
9330	95-00301-03-PV	ST. CLAIR	166	72
STA.	TO STA.			
FED. ROAD DIST. NO.	ILLINOIS	FED. AID PROJECT		

INTERSECTION DETAILS
CONTRACT NO.: 97372

BY	DATE

DATE	BY

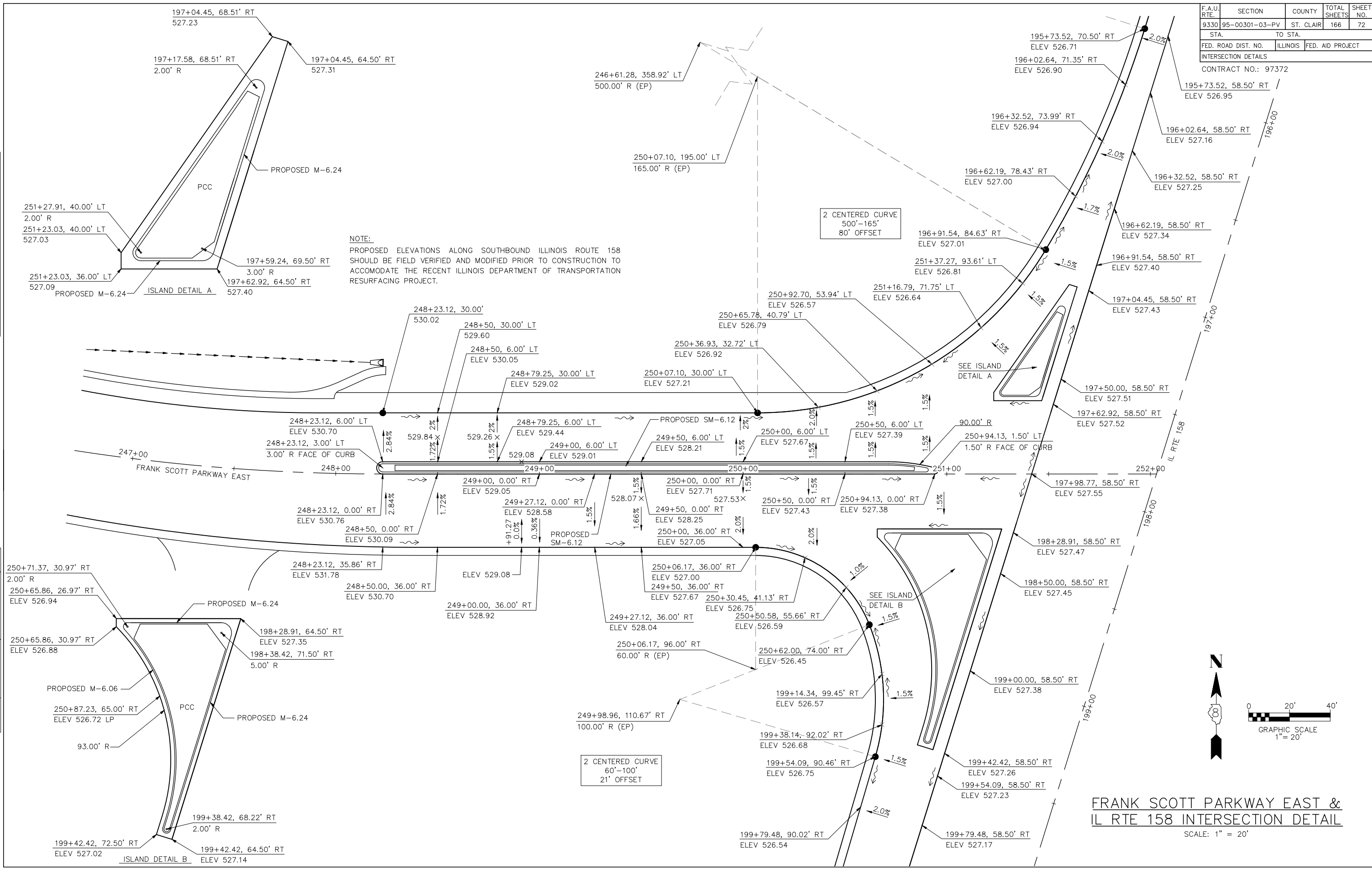

NOTE:
PROPOSED ELEVATIONS ALONG SOUTHBOUND ILLINOIS ROUTE 158 SHOULD BE FIELD VERIFIED AND MODIFIED PRIOR TO CONSTRUCTION TO ACCOMMODATE THE RECENT ILLINOIS DEPARTMENT OF TRANSPORTATION RESURFACING PROJECT.

FRANK SCOTT PARKWAY EAST & IL RTE 158 INTERSECTION DETAIL

SCALE: 1" = 20'

F.A.U. RTE.	SECTION	COUNTY	TOTAL SHEETS	SHEET NO.
9330	95-00301-03-PV	ST. CLAIR	166	73
STA.		TO STA.		
FED. ROAD DIST. NO.		ILLINOIS		FED. AID PROJECT
INTERSECTION DETAILS				

CONTRACT NO.: 97372

BY	DATE

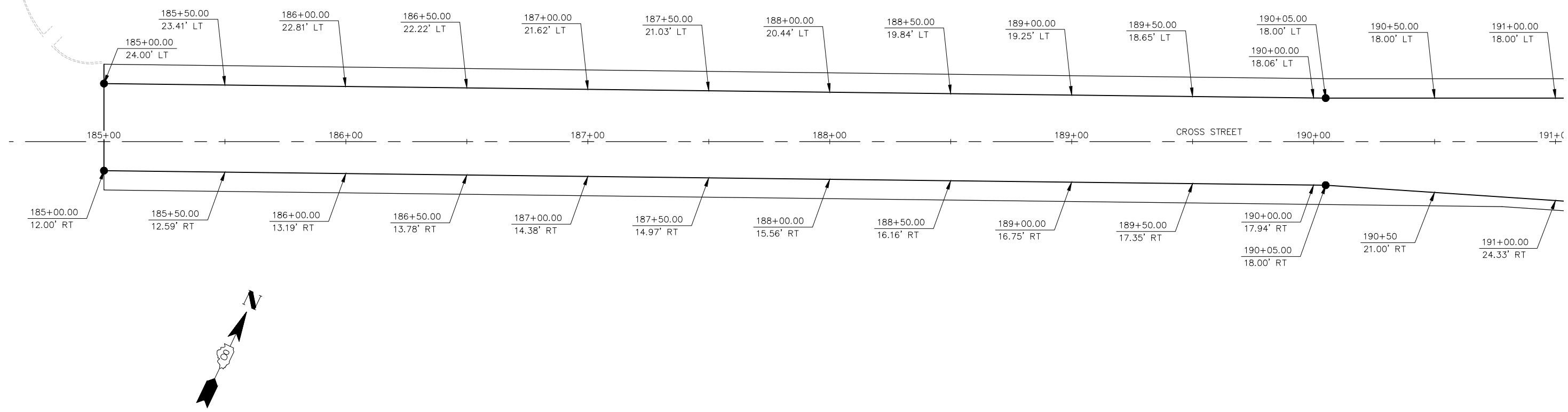

CROSS STREET INTERSECTION DETAIL

SCALE: 1" = 20'

BY	DATE

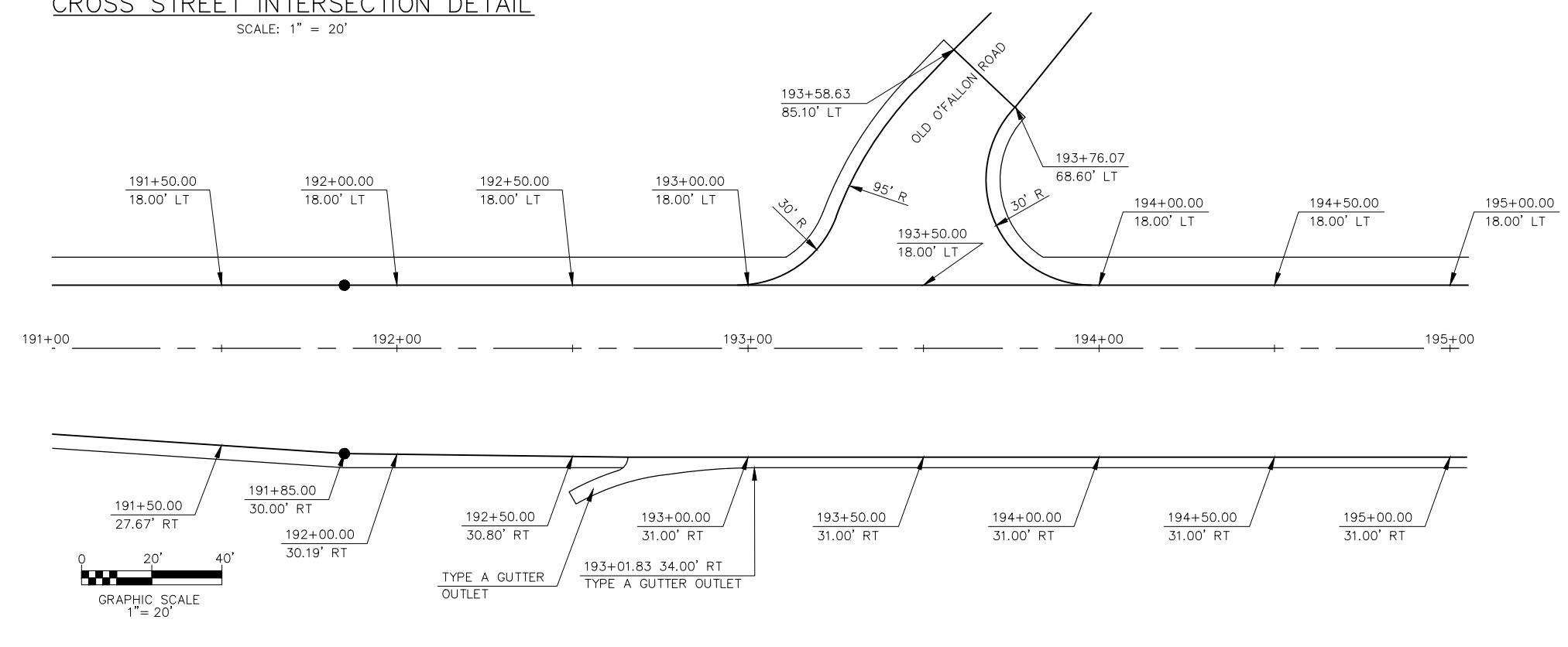

SEE INTERESECTION DETAILS FOR ADDITIONAL INFO

F.A.U. RTE.	SECTION	COUNTY	TOTAL SHEETS	SHEET NO.
9330	95-00301-03-PV	ST. CLAIR	166	74
STA. 156+00 TO STA. 192+00				
FED. ROAD DIST. NO. ILLINOIS		FED. AID PROJECT		
PAVEMENT MARKING PLAN				

CONTRACT NO.: 97372

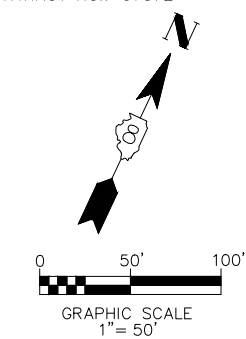

BY	DATE

FINAL SURVEY PLOTTED	NOTE BOOK TEMPLATE AREAS CHECKED

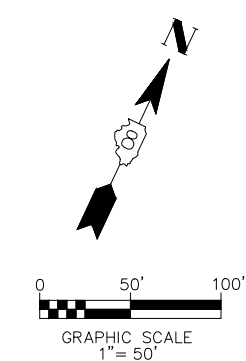
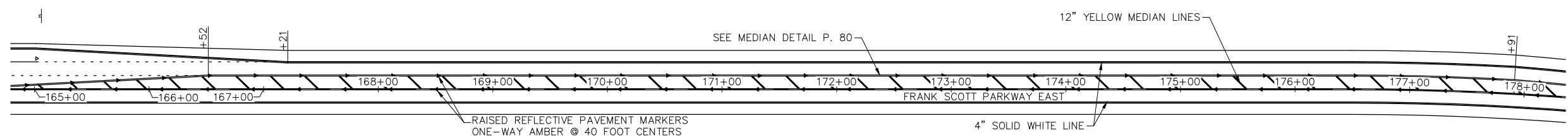
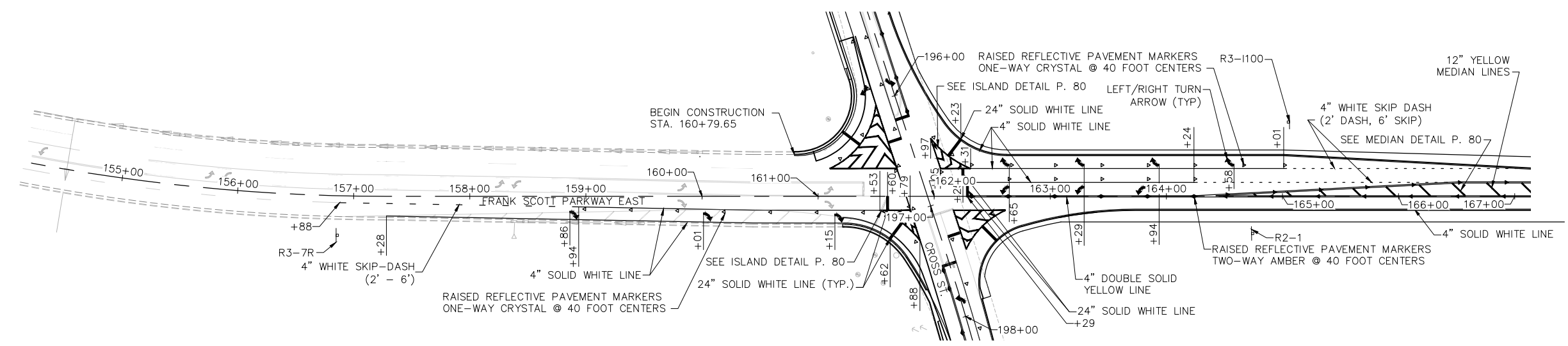

BY	DATE

ORIGINAL SURVEY PLOTTED	NOTE BOOK TEMPLATE AREAS CHECKED

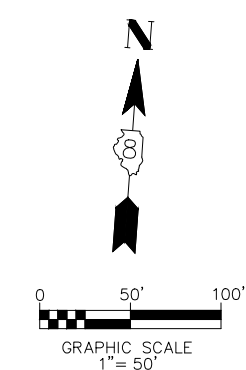
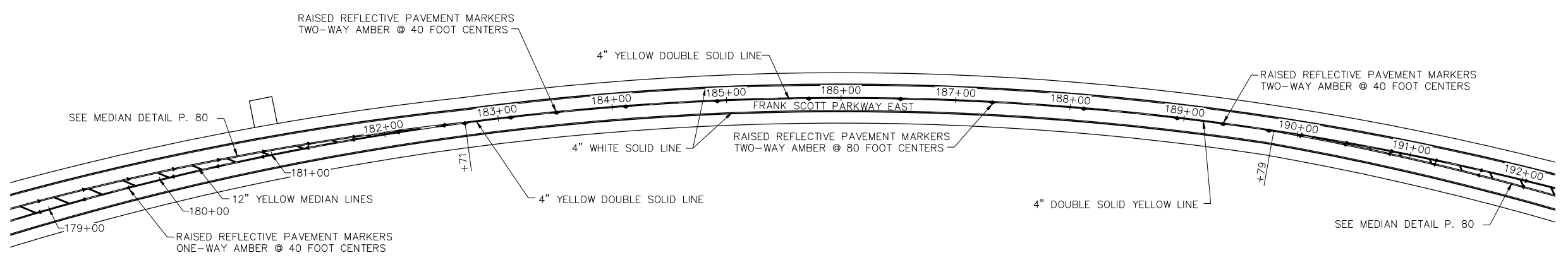

F.A.U. RTE.	SECTION	COUNTY	TOTAL SHEETS	SHEET NO.
9330	95-00301-03-PV	ST. CLAIR	166	75
STA. 192+00 TO STA. 231+00				
FED. ROAD DIST. NO. ILLINOIS		FED. AID PROJECT		
PAVEMENT MARKING PLAN				

CONTRACT NO.: 97372

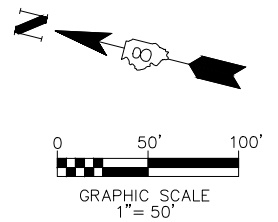
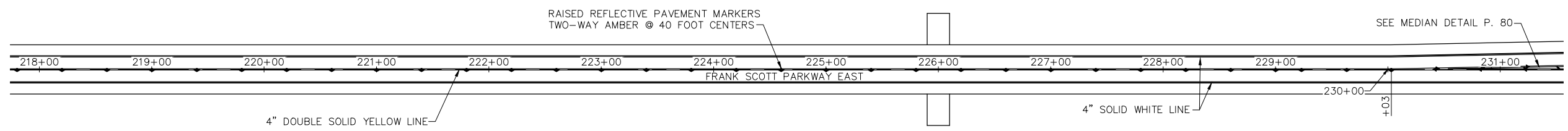
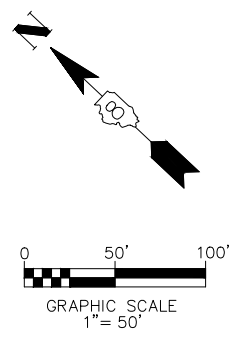
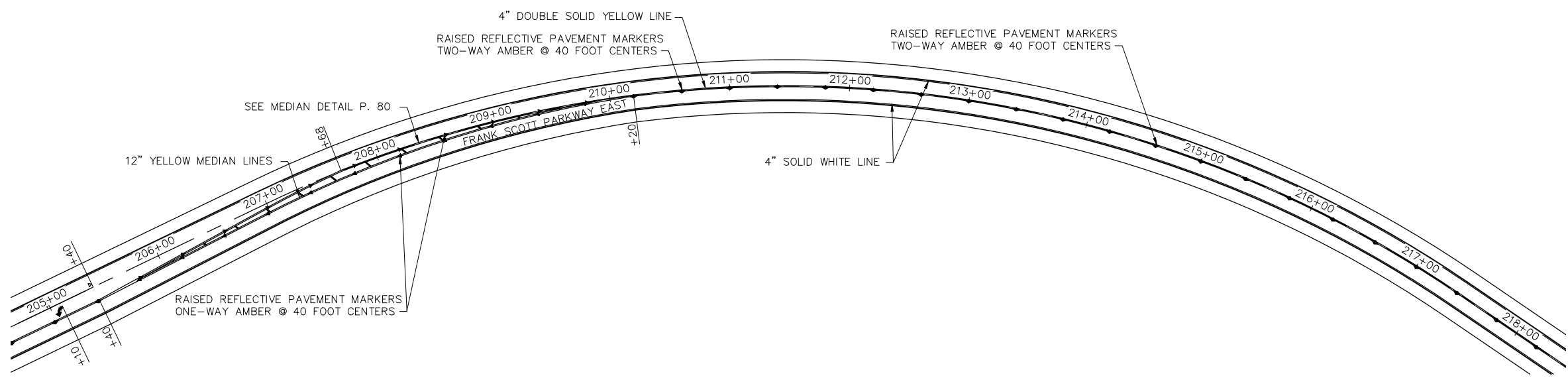
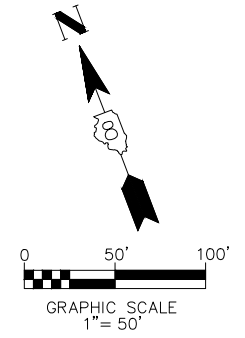
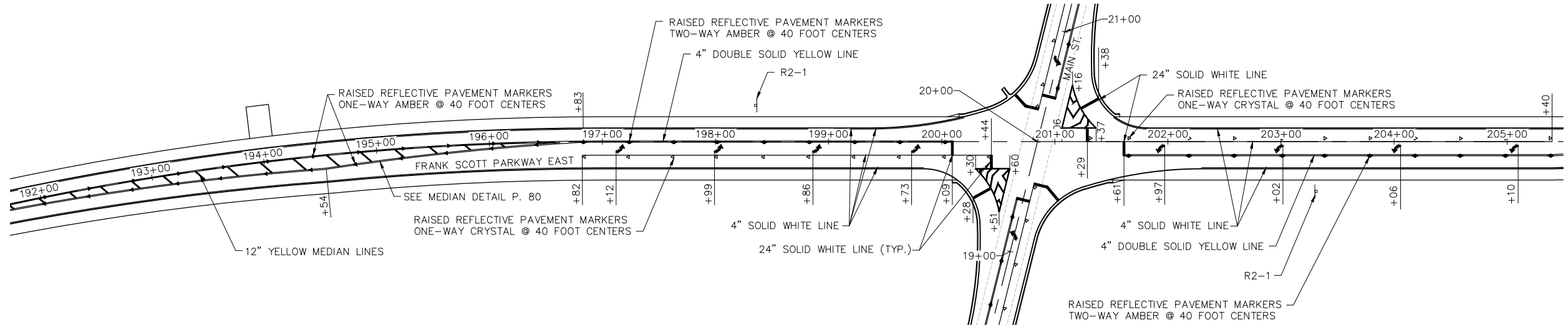

BY	DATE

BY	DATE

F.A.U. RTE.	SECTION	COUNTY	TOTAL SHEETS	SHEET NO.
9330	95-00301-03-PV	ST. CLAIR	166	76
STA. 230+00 TO STA. 252+00				
FED. ROAD DIST. NO. ILLINOIS		FED. AID PROJECT		
PAVEMENT MARKING PLAN				
CONTRACT NO.: 97372				

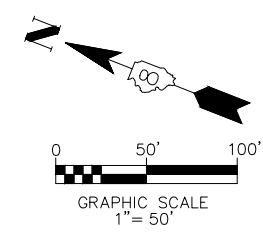
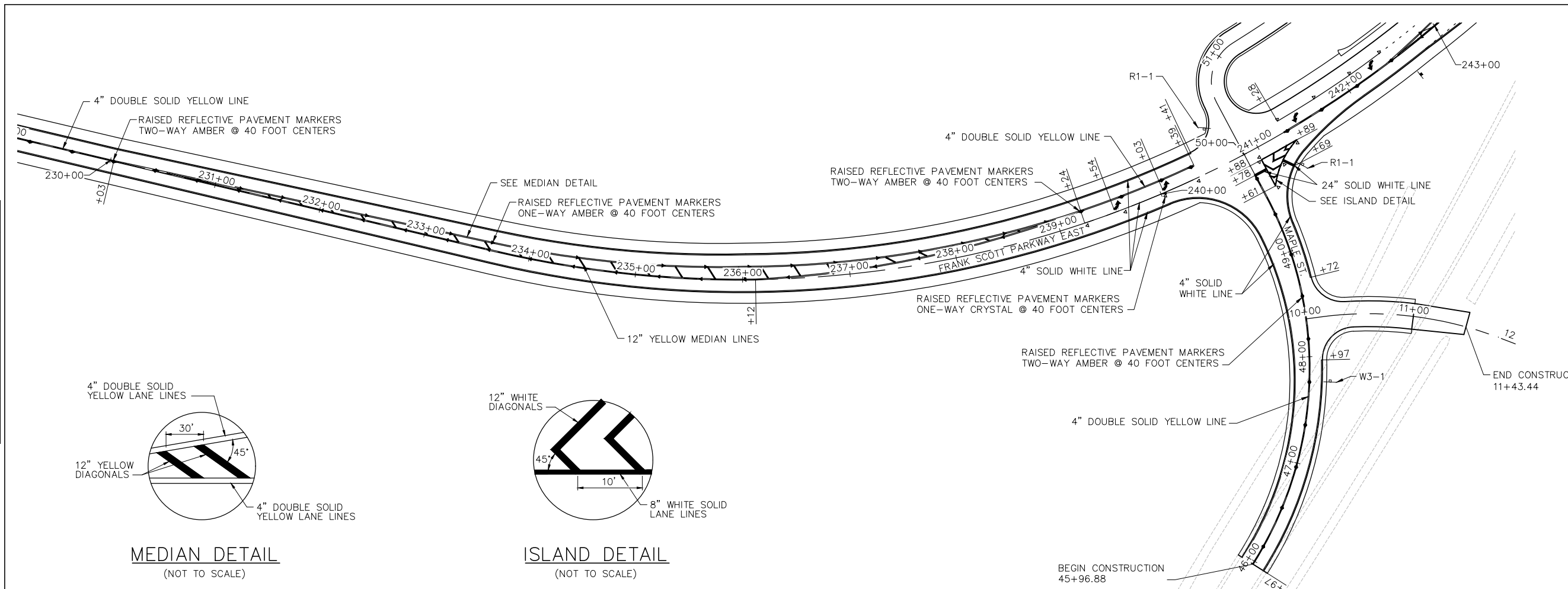

BY	DATE

BY	DATE

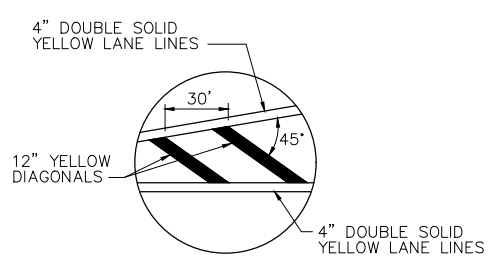

MEDIAN DETAIL
(NOT TO SCALE)

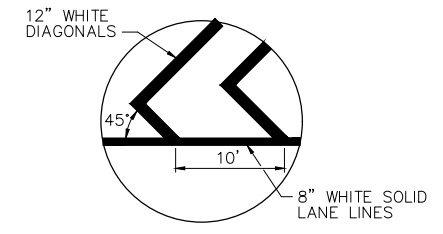

ISLAND DETAIL
(NOT TO SCALE)

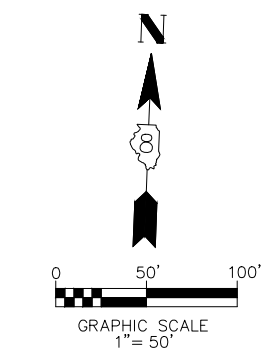
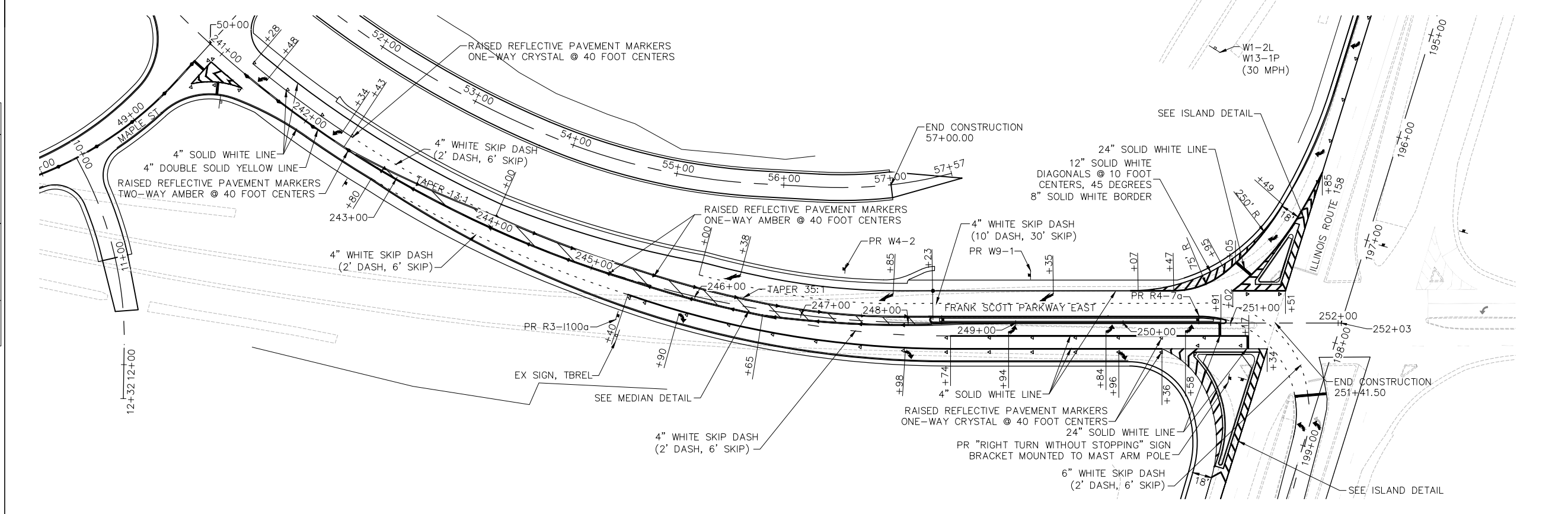

F.A.U. RTE.	SECTION	COUNTY	TOTAL SHEETS	SHEET NO.
9330	95-00301-03-PV	ST. CLAIR	166	77
STA. 187+00 TO STA. 205+00				
FED. ROAD DIST. NO.		ILLINOIS	FED. AID PROJECT	
PAVEMENT MARKING PLAN				
CONTRACT NO.: 97372				

BY	DATE

BY	DATE

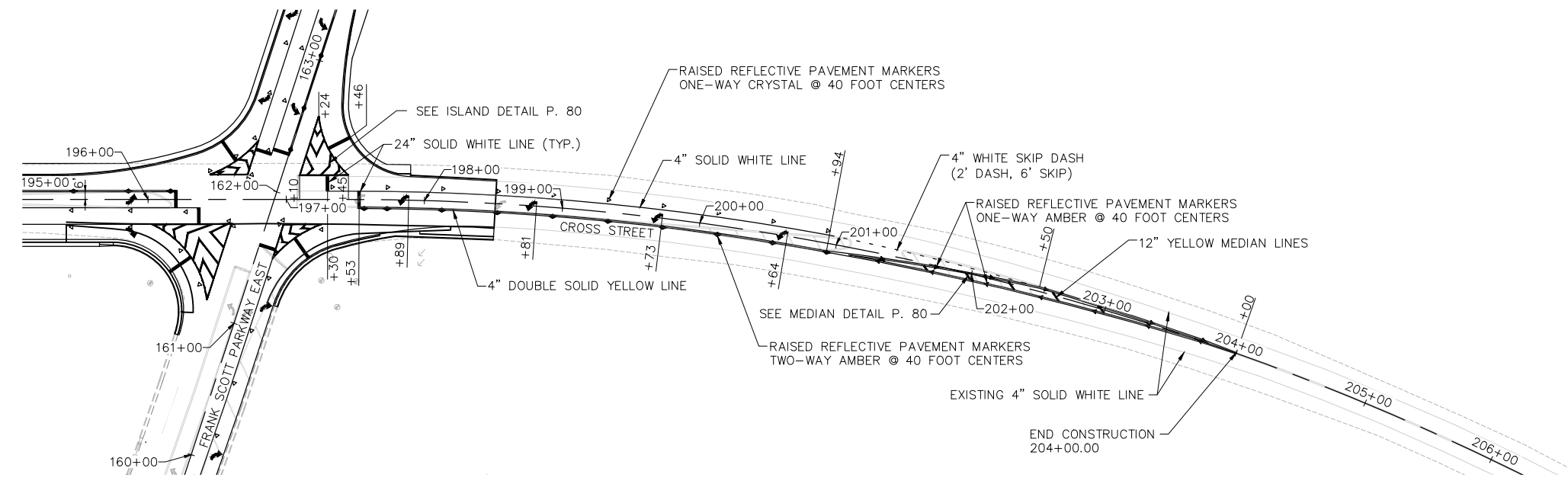
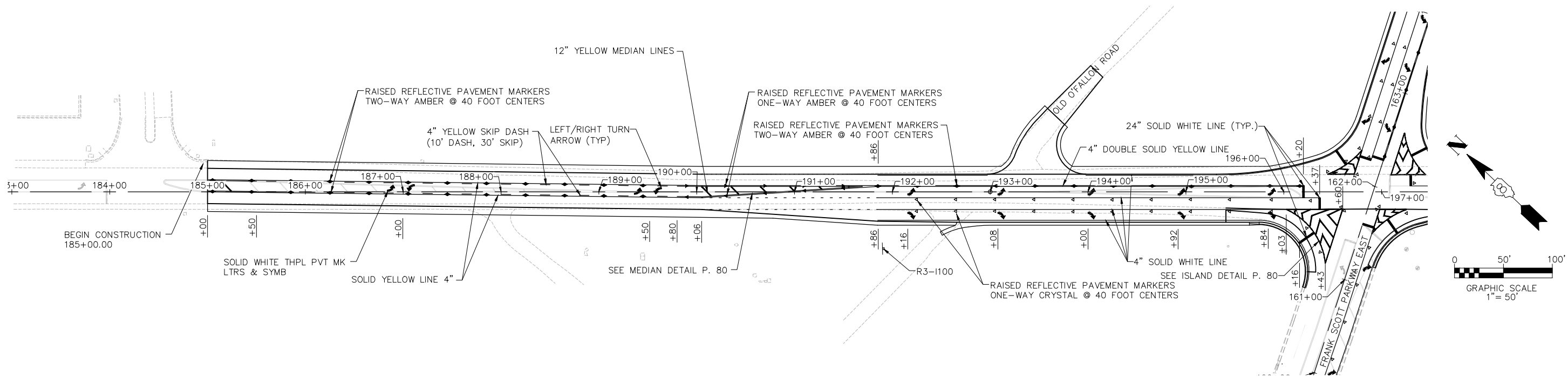

CROSS STREET

F.A.U. RTE.	SECTION	COUNTY	TOTAL SHEETS	SHEET NO.
9330	95-00301-03-PV	ST. CLAIR	166	78
STA. 187+00 TO STA. 205+00				
FED. ROAD DIST. NO.		ILLINOIS	FED. AID PROJECT	
PAVEMENT MARKING PLAN				

CONTRACT NO.: 97372

BY	DATE

BY	DATE

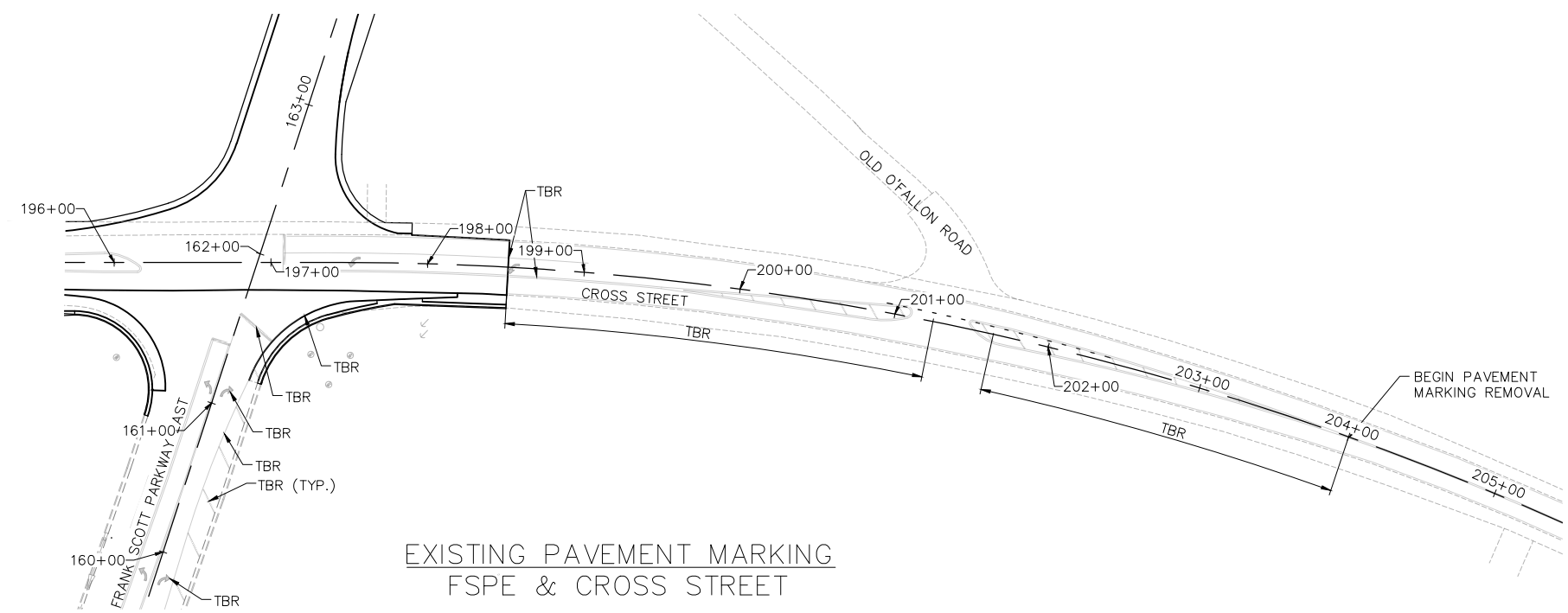
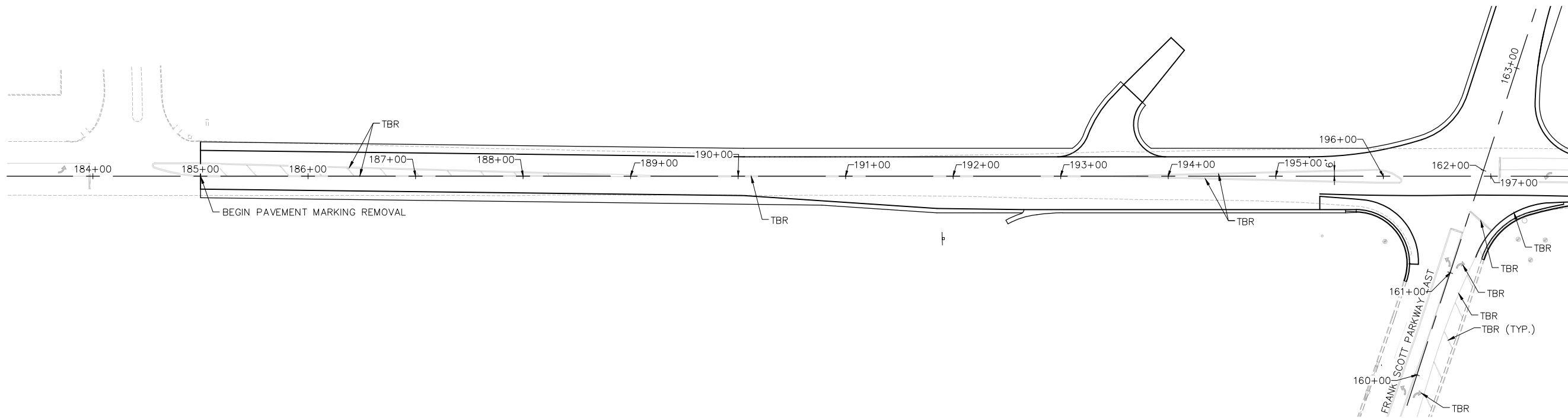

EXISTING PAVEMENT MARKING
FSPE & CROSS STREET

F.A.U. RTE.	SECTION	COUNTY	TOTAL SHEETS	SHEET NO.
9330	95-00301-03-PV	ST. CLAIR	166	79
STA. 10+00 TO STA. 31+00				
FED. ROAD DIST. NO.	ILLINOIS	FED. AID PROJECT		
PAVEMENT MARKING PLAN				
CONTRACT NO.: 97372				

BY	DATE

BY	DATE

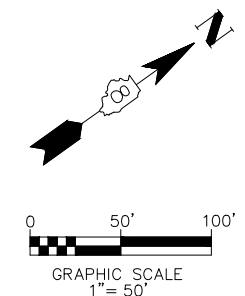
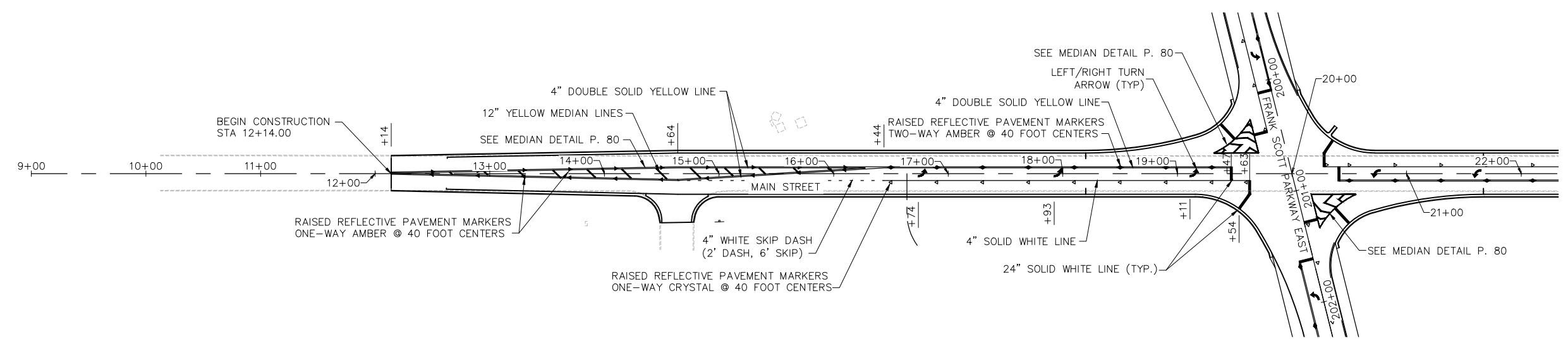

NOTE: STA 12+14 TO STA 18+20 - THERMOPLASTIC PAVEMENT MARKINGS
 STA 18+20 TO STA 21+68 - PAINT PAVEMENT MARKINGS
 STA 21+68 TO STA 28+01 - THERMOPLASTIC PAVEMENT MARKINGS

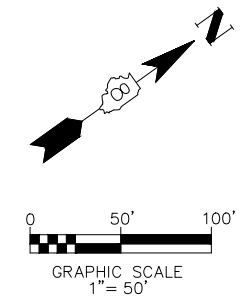
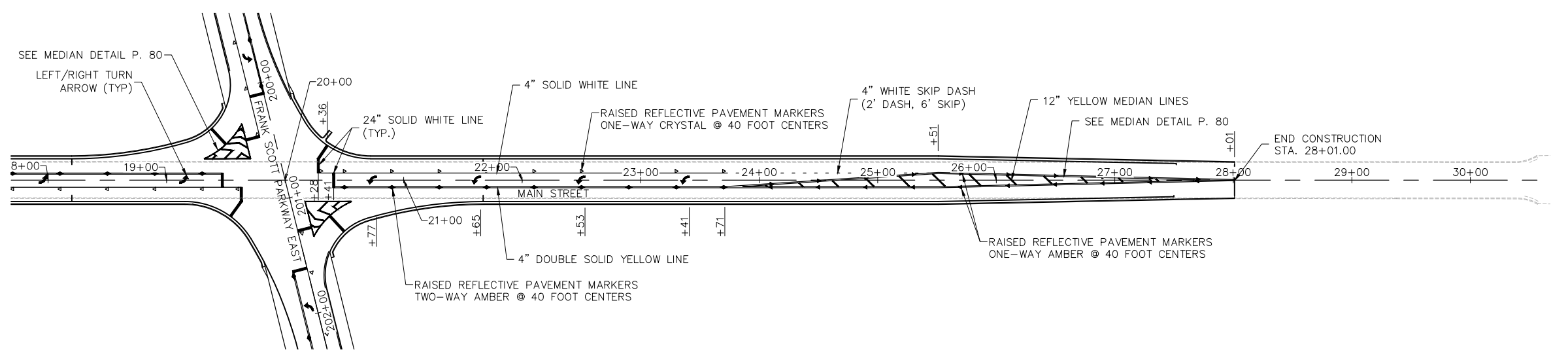

F.A.U. RT.	SECTION	COUNTY	TOTAL SHEETS	SHEET NO.
9330	95-00301-03-PV	ST. CLAIR	166	80
STA. 192+00 TO STA. 214+00				
FED. ROAD DIST. NO. ILLINOIS		FED. AID PROJECT		
PAVEMENT MARKING PLAN				
CONTRACT NO.: 97372				

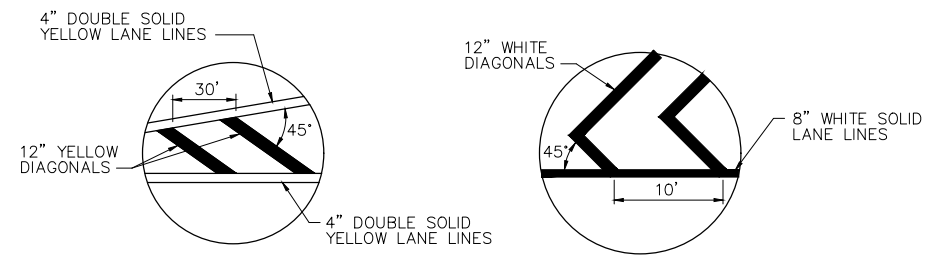
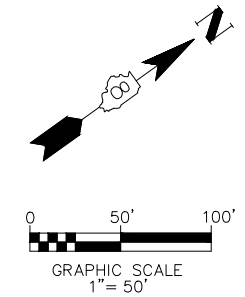
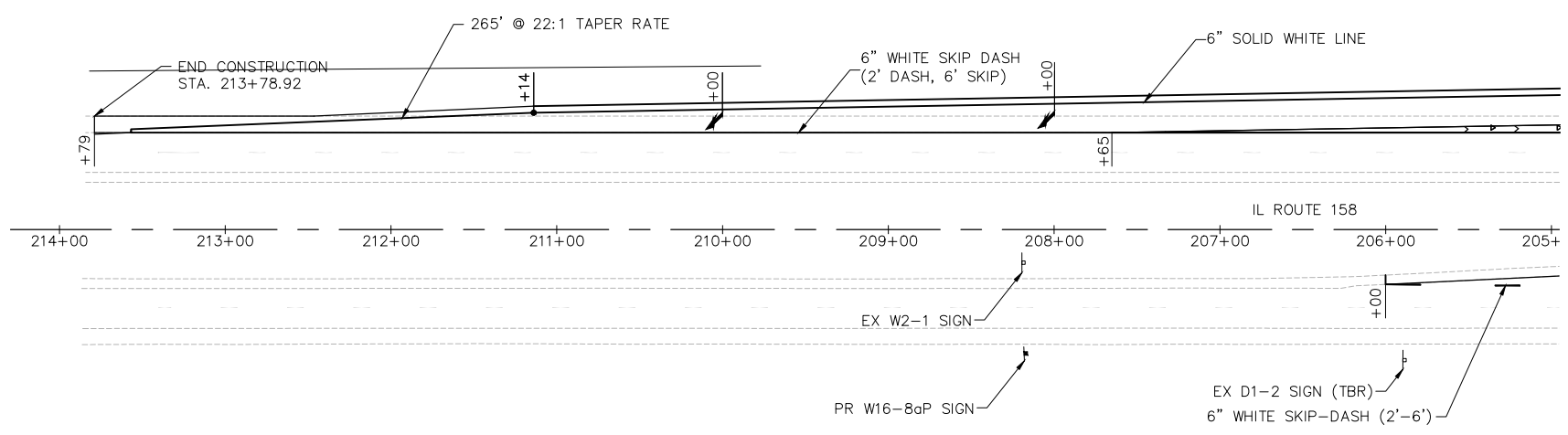
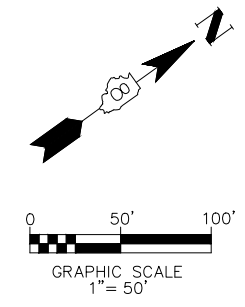
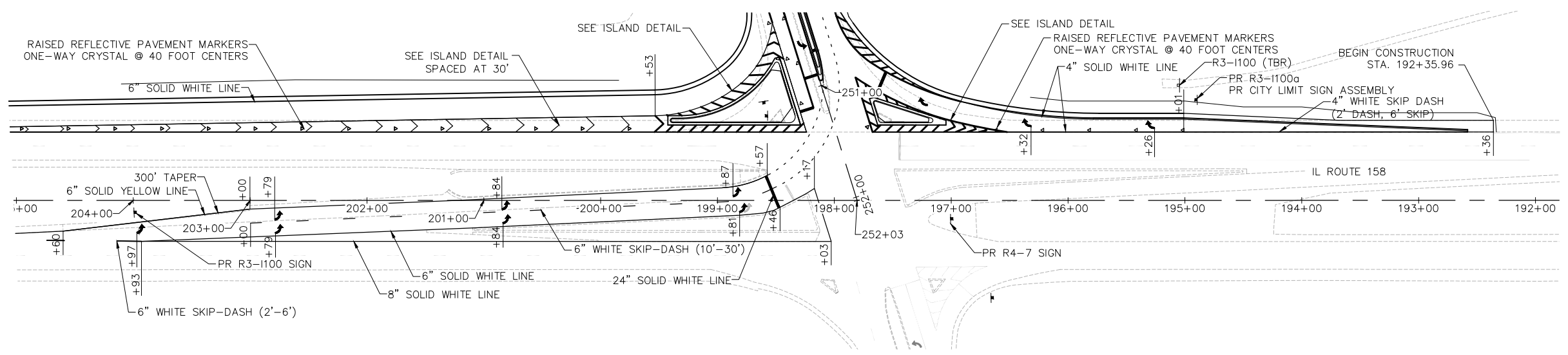

MEDIAN DETAIL
(NOT TO SCALE)

ISLAND DETAIL
(NOT TO SCALE)

BY	DATE

BY	DATE

F.A.U. RTE.	SECTION	COUNTY	TOTAL SHEETS	SHEET NO.
9330	95-00301-03-PV	ST. CLAIR	166	81
STA.	TO STA.			
FED. ROAD DIST. NO.	ILLINOIS	FED. AID PROJECT		
DETAILS				

CONTRACT NO.: 97372

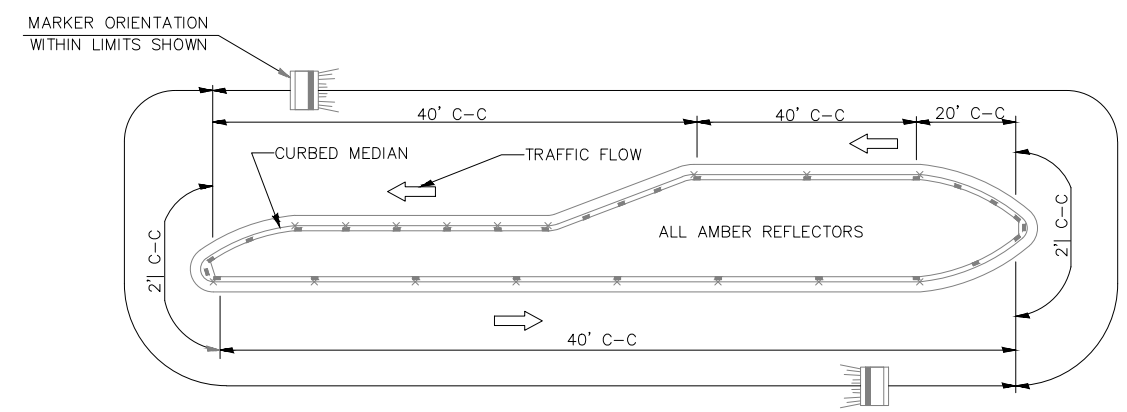

- NOTES
1. PRISMATIC REFLECTORS SHALL BE MONO-DIRECTIONAL AND POSITIONED SO THAT THE REFLECTIVE FACE IS FACING THE APPROACHING TRAFFIC.
 2. PRISMATIC REFLECTORS SHALL BE SECURED IN PLACE WITH AN EPOXY ADHESIVE.
 3. PRISMATIC REFLECTORS SHALL BE EITHER AMBER OR CRYSTAL IN COLOR.

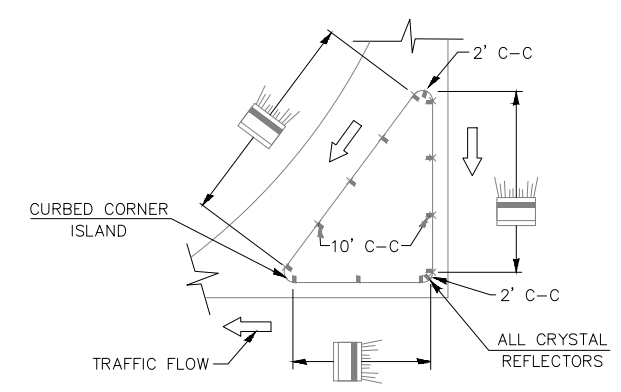
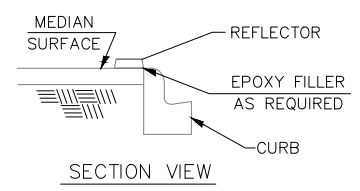

TYPICAL PLACEMENT OF PRISMATIC REFLECTORS ON CURBS
(NO SCALE)

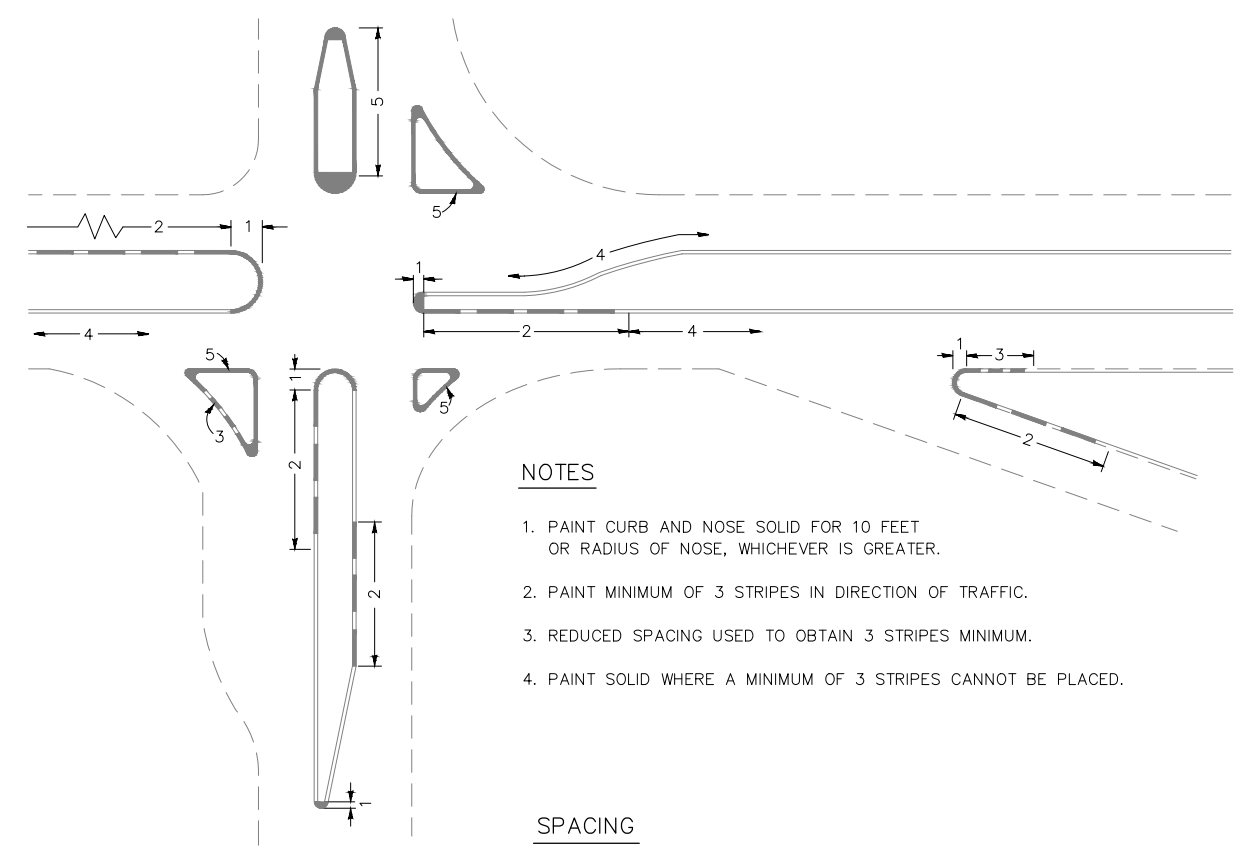

NOTES

1. PAINT CURB AND NOSE SOLID FOR 10 FEET OR RADIUS OF NOSE, WHICHEVER IS GREATER.
2. PAINT MINIMUM OF 3 STRIPES IN DIRECTION OF TRAFFIC.
3. REDUCED SPACING USED TO OBTAIN 3 STRIPES MINIMUM.
4. PAINT SOLID WHERE A MINIMUM OF 3 STRIPES CANNOT BE PLACED.

SPACING

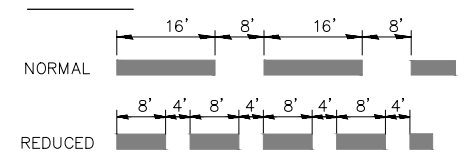

CURB MARKING

F.A.U. RTE.	SECTION	COUNTY	TOTAL SHEETS	SHEET NO.
9330	95-00301-03-PV	ST. CLAIR	166	82
STA.		TO STA.		
FED. ROAD DIST. NO.		ILLINOIS	FED. AID PROJECT	
TRAFFIC SIGNAL PLANS				

CONTRACT NO.: 97372

ELECTRICAL GENERAL NOTES

- ALL SIGNAL HEADS SHALL BE POLYCARBONATE AND SHALL HAVE 12" LENSES. MOUNTING HARDWARE SHALL BE UNPAINTED ALUMINUM. ALL BOLTS, SCREW, NUTS AND WASHERS SHALL BE STAINLESS STEEL. ANTI-SIEZE PASTE COMPOUND SHALL BE USED ON ALL MOUNTING HARDWARE FIELD CONNECTIONS.
- BACKPLATES SHALL BE ABS PLASTIC.
- CONTROLLER CABINETS, SIGNAL POSTS AND BASES SHALL BE UNPAINTED ALUMINUM.
- THE LOCATION OF MAST ARM SUPPORTS SHALL BE APPROVED BY THE ENGINEER BEFORE FOUNDATIONS ARE CONSTRUCTED. MAST ARM POLES SHALL BE LOCATED A MINIMUM OF TEN (10) FEET FROM THE EDGE OF PAVEMENT OR TWO (2) FEET FROM THE EDGE OF SHOULDER, WHICHEVER DISTANCE IS GREATER. IN CURBED SECTIONS, THE MAST ARM POLES SHALL BE LOCATED A MINIMUM OF FIVE (5) FEET FROM THE FACE OF THE CURB. THESE DISTANCES ARE TO THE NEAR FACE OF THE MAST ARM POLE.
- ALL TRAFFIC SIGNAL CABLE SHALL BE #14 AWG STRANDED COPPER UNLESS OTHERWISE SPECIFIED. THERE SHALL BE FOUR (4) GROUND RODS IN THE CONTROLLER CABINET. GROUND WIRES SHALL BE #6 AWG STRANDED, BARE COPPER.
- ALL PROPOSED CONDUIT SHALL BE PVC UNLESS NOTED OTHERWISE. ALL CONDUIT SHALL BE PLACED AND BACKFILLED PRIOR TO CONSTRUCTION OF NEW PAVEMENT, SHOULDER, AND CURB. NO ADDITIONAL COMPENSATION WILL BE ALLOWED FOR PUSHING CONDUIT AFTER SUCH WORK HAS BEEN COMPLETED.
- THE LOCATION OF ALL DETECTOR LOOPS SHALL BE APPROVED BY THE ENGINEER BEFORE ANY SLOTS ARE SAWED IN THE PAVEMENT.
- DETECTOR LOOPS LOCATED WITHIN HOT-MIX ASPHALT SURFACE LIMITS SHALL BE INSTALLED IN THE PAVEMENT PRIOR TO HMA SURFACE PLACEMENT. DETECTOR LOOPS SHALL BE A MINIMUM OF 4 INCHES DEEP, MEASURED FROM THE FINAL PAVEMENT SURFACE ELEVATION.
- THE OPTICAL UNIT OF ALL TRAFFIC SIGNAL HEADS SHALL BE LIGHT EMITTING DIODES (LED) INSTEAD OF INCANDESCENT BULBS.
- DETECTOR LOOP LEAD-IN SPLICES SHALL BE MADE IN A HANDHOLE PER SECTION 873 OF THE "STANDARD SPECIFICATIONS FOR ROAD AND BRIDGE CONSTRUCTION". CONDUCTORS SHALL BE SPLICED IN A RIGID MOLD FILLED WITH NON-HARDENING EPOXY FILLER. RESIN CORE SOLDER SHALL BE USED.
- CALL DELAY SHALL NOT FUNCTION WHEN THE RELATED PHASES ARE IN THE GREEN MODE. "CALL CARRY-OVER" SHALL FUNCTION ONLY WHEN THE RELATED PHASES ARE IN THE GREEN MODE.
- ALL INDUCTION LOOP DETECTOR AMPLIFIERS SUPPLIES FOR THIS INTERSECTION SHALL BE RACK MOUNTED AND SHALL HAVE THE CAPACITY OF OPERATING WITH BOTH DELAY AND EXTENSION MODES ACTIVE, IF A TIME SETTING IS PROGRAMMED.
- SLOPE HANDHOLE COVERS TO MATCH PROPOSED GRADE ELEVATIONS.
- ALL UTILITIES SHALL BE LOCATED IN THE FIELD PRIOR TO ANY ATTEMPT TO CONSTRUCT ANY COMPONENT OF THE VARIOUS TRAFFIC SIGNAL INSTALLATIONS. AGENCIES KNOWN TO HAVE FACILITIES WITHIN THE LIMITS OF THIS IMPROVEMENT ARE THE FOLLOWING:
 AMEREN IP (GAS & ELECTRIC)
 AT&T (TELEPHONE)
 CHARTER COMMUNICATIONS (COMMUNICATIONS)
 ILLINOIS AMERICAN WATER (WATER)
 VILLAGE OF SHILOH (SEWER)
 ILLINOIS DEPARTMENT OF TRANSPORTATION (TRAFFIC SIGNALS)
 MCI/VERIZON (TELEPHONE)
- THE LOCATION OF EXISTING UTILITIES AS SHOWN ON THE PLANS HAVE BEEN LOCATED AT THE TIME OF SURVEY, OR BASED ON AVAILABLE EXISTING INFORMATION. NO GUARANTEE IS IMPLIED THAT ALL UTILITIES HAVE BEEN LOCATED OR DEPICTED ON THE PLANS. THE CONTRACTOR SHALL BE RESPONSIBLE FOR VERIFYING THE EXACT LOCATION OF ALL UTILITIES. IT MAY BE NECESSARY TO HAND DIG TEST HOLES TO EXPOSE EXISTING UTILITIES AT SOME LOCATIONS.
- SEE "JOINT UTILITY LOCATION INFORMATION FOR EXCAVATORS" (JULIE) IN THE SPECIAL PROVISIONS. CALL (800) 892-0123 ONE WEEK BEFORE PLANNING TO DIG.
- CONDUIT SPLICES WILL NOT BE PAID FOR SEPARATELY, BUT SHALL BE CONSIDERED PART OF THE NEW CONDUIT INSTALLATION.
- THE CONTRACTOR SHALL INSTALL THE STREET NAME SIGNS ON THE MAST ARMS AS SHOWN ON THE PLANS AS FOLLOWS:
 CROSS STREET
 ONE SIGN, N.W. QUAD., VISIBLE TO W.B. TRAFFIC (C)
 MAIN STREET
 ONE SIGN, N.W. QUAD., VISIBLE TO W.B. TRAFFIC (D)
 ONE SIGN, S.W. QUAD., VISIBLE TO S.B. TRAFFIC (B)
 ONE SIGN, S.E. QUAD., VISIBLE TO E.B. TRAFFIC (D)
 ONE SIGN, N.E. QUAD., VISIBLE TO N.B. TRAFFIC (B)
 ILLINOIS ROUTE 158
 ONE SIGN, N.E. QUAD., VISIBLE TO N.B. TRAFFIC (E)
 ONE SIGN, S.W. QUAD., VISIBLE TO S.B. TRAFFIC (F)

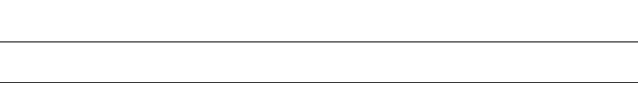
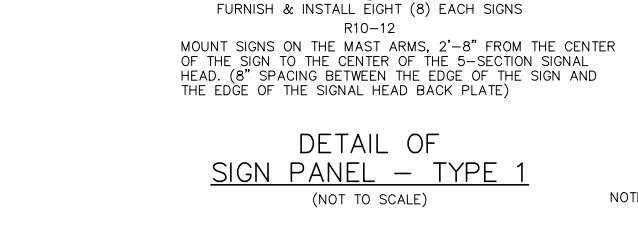
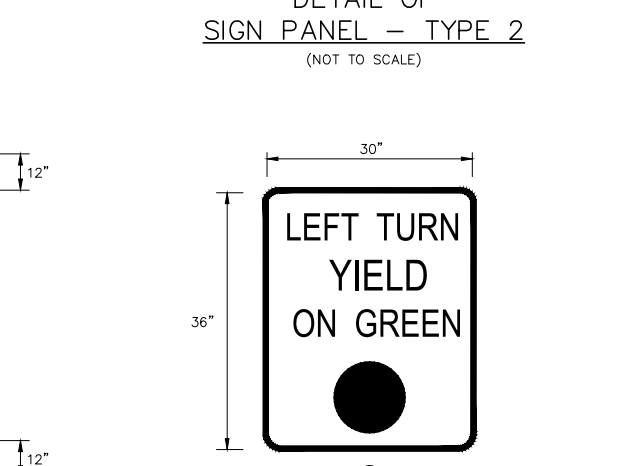
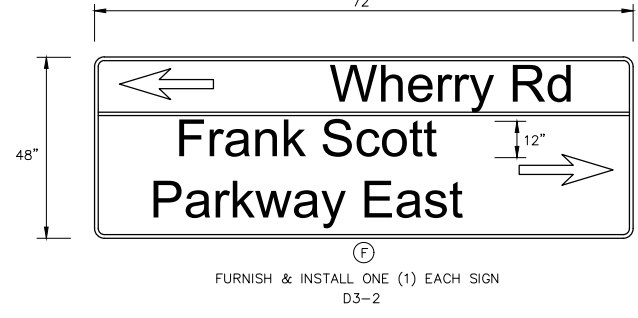
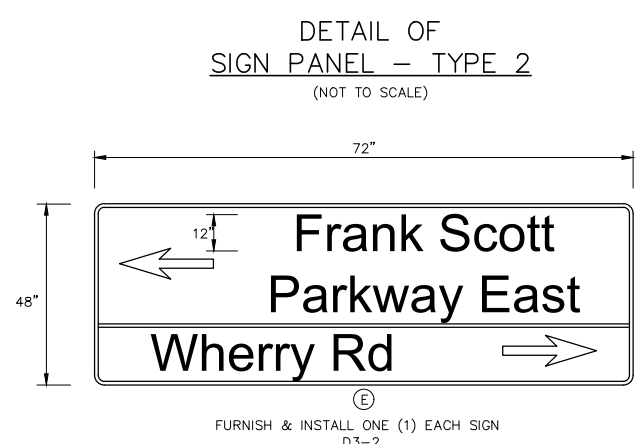
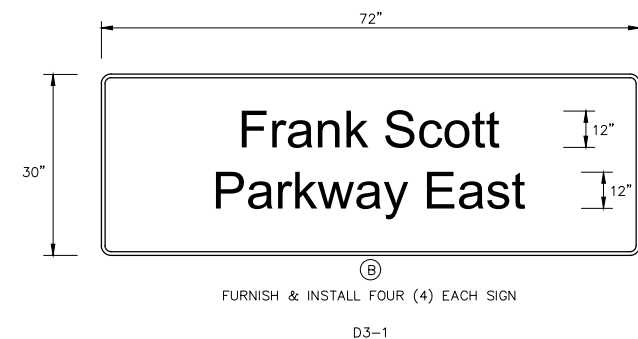

DETECTOR LOOP REQUIREMENTS & CALCULATIONS FRANK SCOTT PARKWAY EAST & CROSS STREET

LOOP #	DIRECTION	PHASE	LOOP SIZE (FOOT)	REQUIRED NUMBER OF TURNS	LEAD-IN CABLE LENGTH (FOOT)	CALCULATED INDUCTANCE (microhenries)	CALCULATED RESISTANCE (ohms)
1	SB RT	C	6' X 50'	3 - 6 - 3	59	799	1.9
2	SB THRU	6	6' X 50'	3 - 6 - 3	81	804	2.0
3	SB LT	1	6' X 50'	3 - 6 - 3	83	808	2.1
4	SB C.C.O.	6	6' X 6'	6	408	345	2.4
5	WB RT	D	6' X 50'	3 - 6 - 3	196	829	2.6
6	WB THRU	4	6' X 50'	3 - 6 - 3	201	830	2.6
7	WB LT	7	6' X 50'	3 - 6 - 3	213	833	2.7
8	WB C.C.O.	4	6' X 6'	6	531	372	3.0
9	NB THRU	2	6' X 50'	3 - 6 - 3	274	846	3.0
10	NB LT	5	6' X 50'	3 - 6 - 3	291	850	3.1
11	NB C.C.O.	2	6' X 6'	7	625	504	3.6
12	EB RT	B	6' X 50'	3 - 6 - 3	156	820	2.4
13	EB THRU	8	6' X 50'	3 - 6 - 3	161	821	2.4
14	EB LT	3	6' X 50'	3 - 6 - 3	173	824	2.5
15	EB C.C.O.	8	6' X 6'	6	511	367	2.9
16	NB RT	A	6' X 50'	3 - 6 - 3	288	849	3.0

THE ABOVE VALUES ARE CALCULATIONS OF COMBINED LOOP AND LEAD-IN INDUCTANCE AND RESISTANCE. ACTUAL MEASURED VALUES SHOULD BE WITHIN 20% OF THESE VALUES.

DETECTOR LOOP REQUIREMENTS & CALCULATIONS FRANK SCOTT PARKWAY EAST & MAIN STREET

LOOP #	DIRECTION	PHASE	LOOP SIZE (FOOT)	REQUIRED NUMBER OF TURNS	LEAD-IN CABLE LENGTH (FOOT)	CALCULATED INDUCTANCE (microhenries)	CALCULATED RESISTANCE (ohms)
1	SB RT	D	6' X 16'	3 - 6 - 3	123	303	1.2
2	SB THRU	4	6' X 50'	3 - 6 - 3	140	817	2.3
3	SB LT	7	6' X 50'	3 - 6 - 3	154	820	2.4
4	SB C.C.O.	4	6' X 6'	6	452	354	2.6
5	WB THRU	2	6' X 50'	3 - 6 - 3	213	833	2.7
6	WB LT	5	6' X 6'	3 - 6 - 3	225	836	2.7
7	WB C.C.O.	2	6' X 6'	6	548	375	3.1
8	NB RT	B	6' X 16'	3 - 6 - 3	115	301	1.2
9	NB THRU	8	6' X 50'	3 - 6 - 3	132	815	2.3
10	NB LT	3	6' X 50'	3 - 6 - 3	152	819	2.4
11	NB C.C.O.	8	6' X 6'	6	388	340	2.3
12	EB THRU	6	6' X 50'	3 - 6 - 3	51	797	1.9
13	EB LT	1	6' X 50'	3 - 6 - 3	63	800	1.9
14	EB C.C.O.	6	6' X 6'	6	381	253	2.2
15	WB RT	A	6' X 50'	3 - 6 - 3	226	836	2.7
16	EB RT	C	6' X 50'	3 - 6 - 3	24	791	1.7

THE ABOVE VALUES ARE CALCULATIONS OF COMBINED LOOP AND LEAD-IN INDUCTANCE AND RESISTANCE. ACTUAL MEASURED VALUES SHOULD BE WITHIN 20% OF THESE VALUES.

DETECTOR LOOP REQUIREMENTS & CALCULATIONS FRANK SCOTT PARKWAY EAST & IL 158

LOOP #	DIRECTION	PHASE	LOOP SIZE (FOOT)	REQUIRED NUMBER OF TURNS	LEAD-IN CABLE LENGTH (FOOT)	CALCULATED INDUCTANCE (microhenries)	CALCULATED RESISTANCE (ohms)
20	EB THRU	3	6' X 50'	3 - 6 - 3	509	903	2.6
21	EB LT	3	6' X 50'	3 - 6 - 3	509	903	2.6
22	EB C.C.O.	3	6' X 6'	6	755	246	0.7
25	EB RT	3	6' X 50'	3 - 6 - 3	430	885	2.6
1	SB RT	3	6' X 50'	3 - 6 - 3	254	845	2.5

MAST ARM FOUNDATION TABLE

MAST ARM #	LOCATION	MAST ARM LENGTH (FOOT)	FOUNDATION DEPTH (FOOT)	FOUNDATION DIAMETER (INCH)
CROSS STREET				
1	N.W. QUAD	60	21	42
2	N.E. QUAD	55	15	36
3	S.E. QUAD	62	21	42
4	S.W. QUAD	62	21	42
MAIN STREET				
5	N.W. QUAD	60	21	42
6	N.E. QUAD	62	21	42
7	S.E. QUAD	55	15	36
8	S.W. QUAD	58	21	42
ILLINOIS ROUTE 158				
9	N.W. QUAD	36	11	36
10	S.W. QUAD	48	13	36

SEE HIGHWAY STANDARD 878001 FOR CONCRETE FOUNDATION DETAILS.

NOTE: ALL D3-1 & D3-2 SIGN LETTERING SIZES SHALL COMPLY WITH MUTCD TABLE 2D-2.

F.A.U. RTE.	SECTION	COUNTY	TOTAL SHEETS	SHEET NO.
9330	95-00301-03-PV	ST. CLAIR	166	83
STA.		TO STA.		
FED. ROAD DIST. NO.		ILLINOIS FED. AID PROJECT		
TRAFFIC SIGNAL PLANS				

CONTRACT NO.: 97372

BY	DATE
FINAL SURVEY PLOTTED	
NOTE BOOK TEMPLATE	
AREAS CHECKED	
NO.	

BY	DATE
ORIGINAL SURVEY PLOTTED	
NOTE BOOK TEMPLATE	
AREAS CHECKED	
NO.	

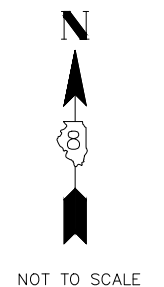
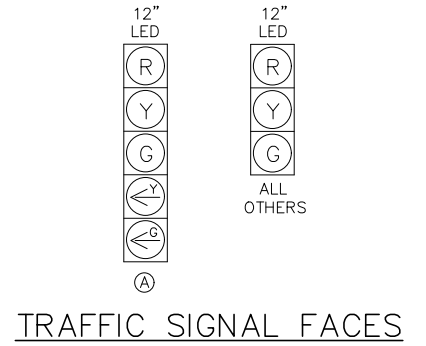
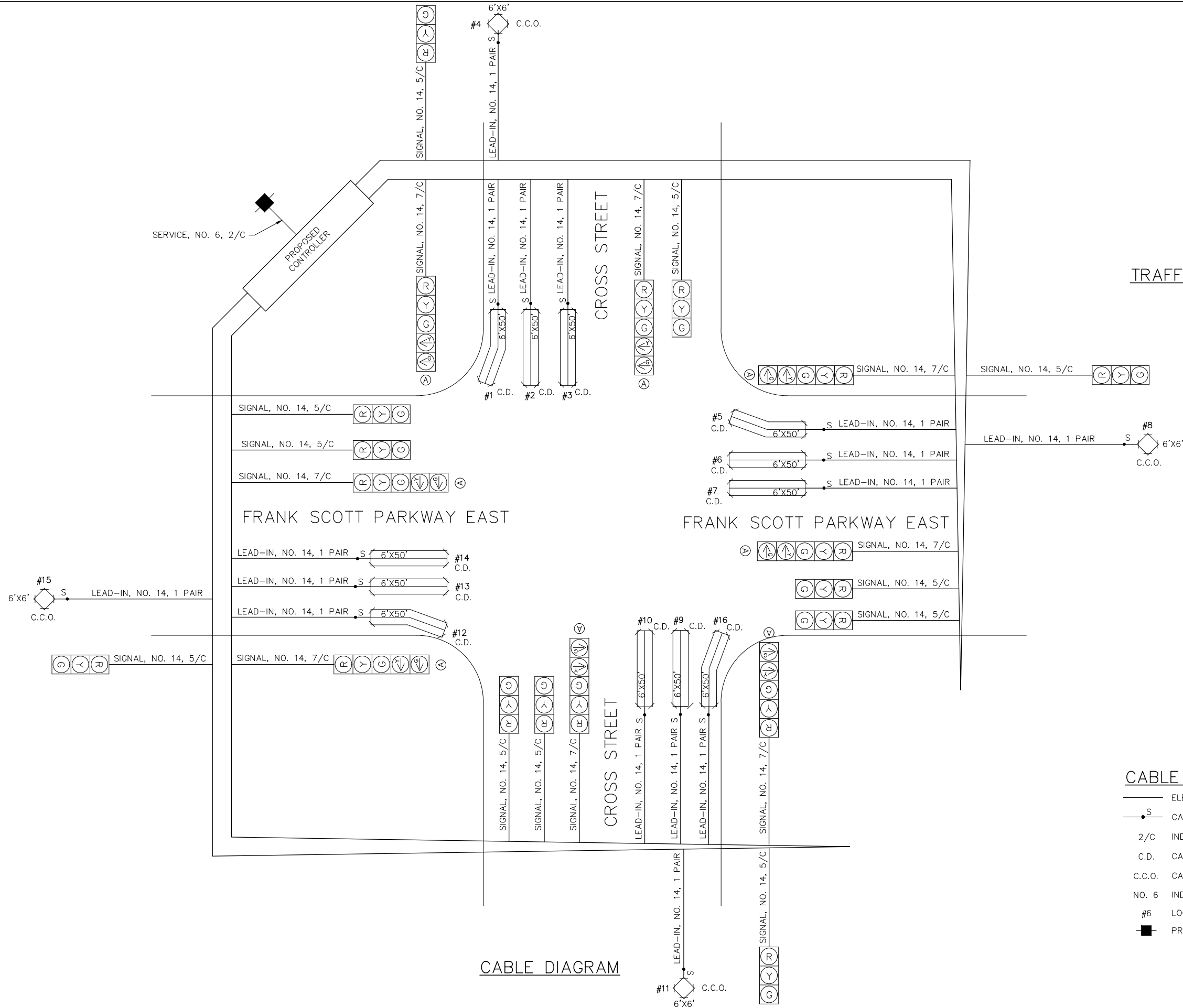

CABLE DIAGRAM LEGEND

- ELECTRIC CABLE IN CONDUIT
- S — CABLE SPLICE (SEE GENERAL NOTES)
- 2/C INDICATES NUMBER OF CONDUCTORS IN CABLE
- C.D. CALL DELAY (SEE GENERAL NOTES)
- C.C.O. CALL CARRY OVER (SEE GENERAL NOTES)
- NO. 6 INDICATES AMERICAN WIRE (AWG) SIZE 6
- #6 LOOP DETECTOR NUMBER
- PROPOSED SERVICE INSTALLATION

CABLE DIAGRAM

F.A.U. RTE.	SECTION	COUNTY	TOTAL SHEETS	SHEET NO.
9330	95-00301-03-PV	ST. CLAIR	166	84
STA.		TO STA.		
FED. ROAD DIST. NO.		ILLINOIS	FED. AID PROJECT	
TRAFFIC SIGNAL PLANS				
CONTRACT NO.: 97372				

TRAFFIC SIGNAL LEGEND

- EXISTING SIGNAL HEAD
- EXISTING HANDHOLE
- EXISTING MAST ARM
- EXISTING CONTROLLER
- PROPOSED SIGNAL HEAD (SEE HIGHWAY STANDARD 880006)
- PROPOSED SIGNAL HEAD WITH BACKPLATE (SEE HIGHWAY STANDARD 880006)
- PROPOSED HANDHOLE (SEE HIGHWAY STANDARD 814001)
- PROPOSED DOUBLE HANDHOLE (SEE HIGHWAY STANDARD 814006)
- PROPOSED DETECTOR LOOP (SEE HIGHWAY STANDARDS 886001 & 886006)
- PROPOSED DETECTOR LOOP (SEE HIGHWAY STANDARDS 886001 & 886006)
- PROPOSED CONDUIT: "T" TRENCH, "P" PUSHED, SIZE SPECIFIED
- PVCC POLYVINYL CHLORIDE CONDUIT
- GSC GALVANIZED STEEL CONDUIT
- PROPOSED SIGN
- PROPOSED MAST ARM (LENGTH SPECIFIED) (SEE HIGHWAY STANDARD 877001 & 878001)
- SERVICE INSTALLATION (SEE HIGHWAY STANDARD 805001 & SPECIAL PROVISIONS)
- PROPOSED CONTROLLER

DATE	BY
DATE	BY
DATE	BY
DATE	BY

DATE	BY
DATE	BY
DATE	BY
DATE	BY

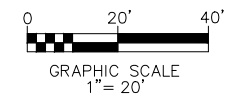

SEQUENCE OF OPERATION

FULL-ACTUATED CONTROLLER AND TYPE IV CABINET								
PHASE Ø	1	2	3	4	5	6	7	8
MOVEMENT								
CONCURRENT MOVEMENT PERMITTED	5 OR 6	5 OR 6	7 OR 8	7 OR 8	1 OR 2	1 OR 2	3 OR 4	3 OR 4

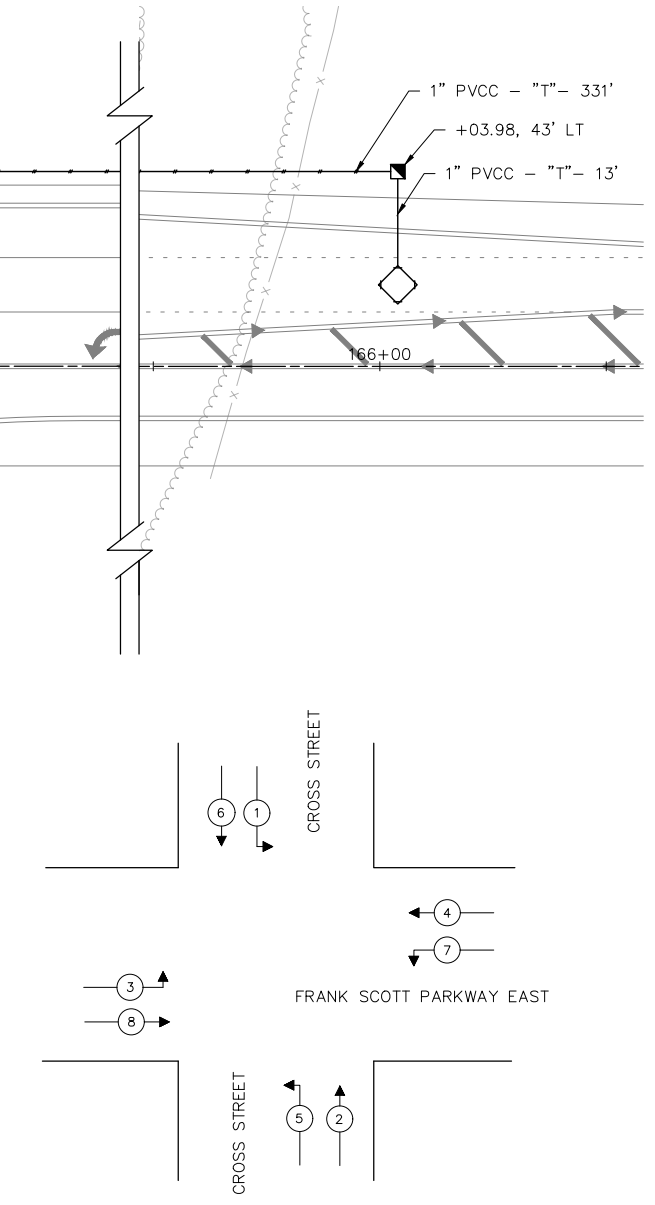
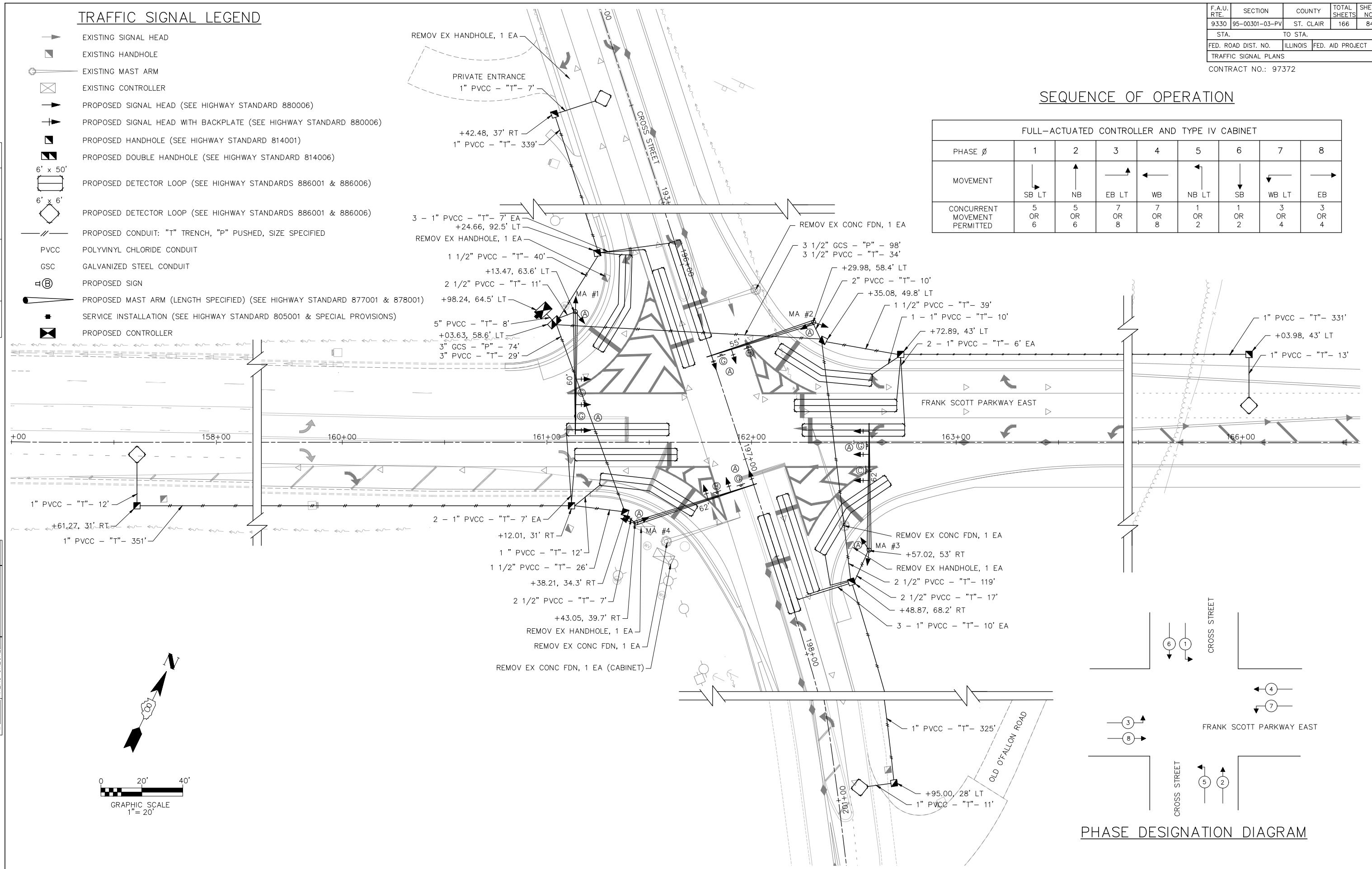

F.A.U. RTE.	SECTION	COUNTY	TOTAL SHEETS	SHEET NO.
9330	95-00301-03-PV	ST. CLAIR	166	85
STA.		TO STA.		
FED. ROAD DIST. NO.		ILLINOIS	FED. AID PROJECT	
TRAFFIC SIGNAL PLANS				

CONTRACT NO.: 97372

FINAL SURVEYED	BY	DATE
SURVEY PLOTTED		
NOTE BOOK TEMPLATE		
AREAS CHECKED		
NO.		

ORIGINAL SURVEYED	BY	DATE
SURVEY PLOTTED		
NOTE BOOK TEMPLATE		
AREAS CHECKED		
NO.		

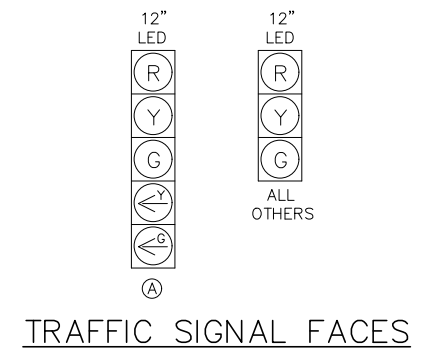
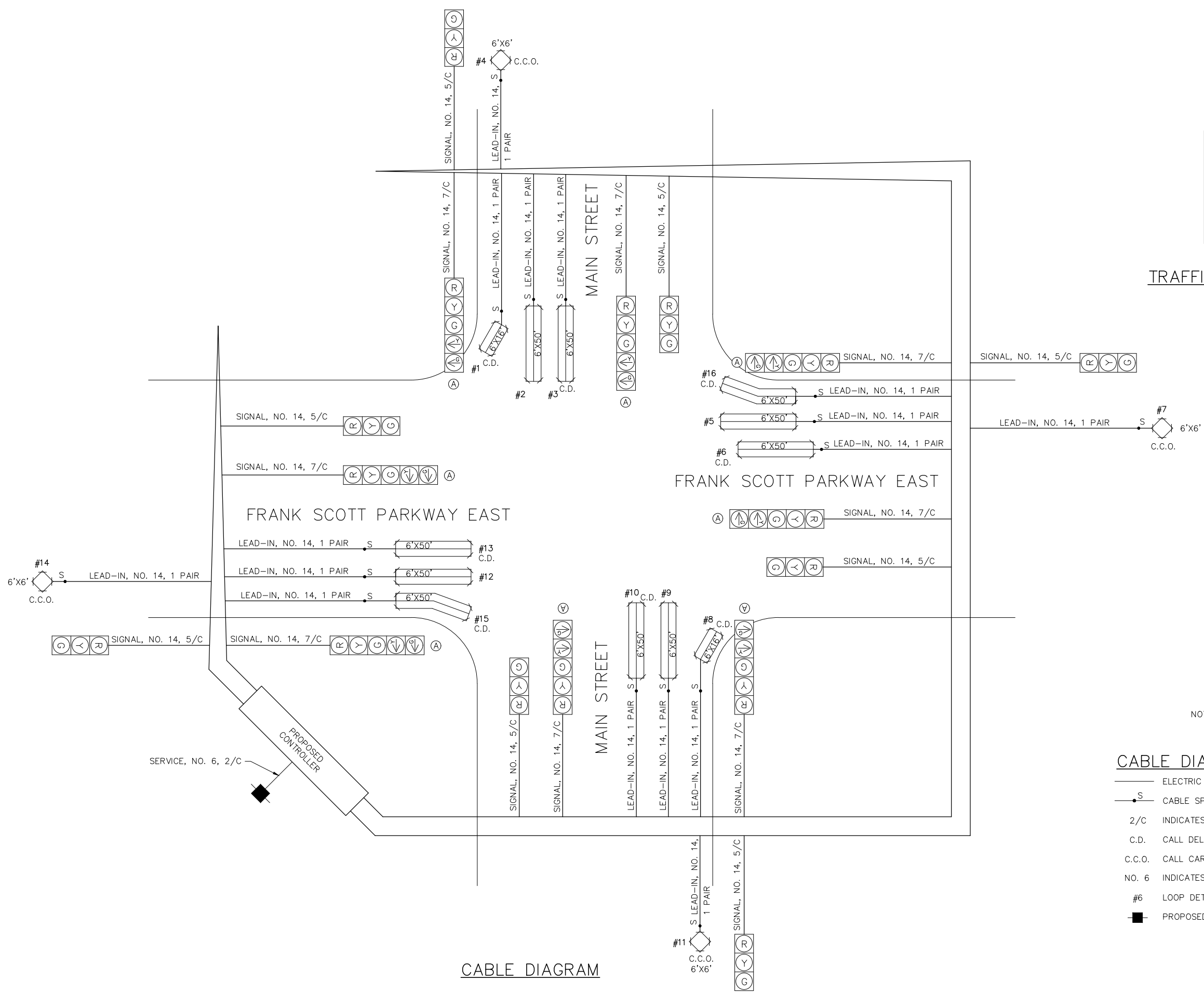

- CABLE DIAGRAM LEGEND**
- ELECTRIC CABLE IN CONDUIT
 - S — CABLE SPLICE (SEE GENERAL NOTES)
 - 2/C INDICATES NUMBER OF CONDUCTORS IN CABLE
 - C.D. CALL DELAY (SEE GENERAL NOTES)
 - C.C.O. CALL CARRY OVER (SEE GENERAL NOTES)
 - NO. 6 INDICATES AMERICAN WIRE (AWG) SIZE 6
 - #6 LOOP DETECTOR NUMBER
 - PROPOSED SERVICE INSTALLATION

CABLE DIAGRAM

F.A.U. RTE.	SECTION	COUNTY	TOTAL SHEETS	SHEET NO.
9330	95-00301-03-PV	ST. CLAIR	166	86
STA.	TO STA.			
FED. ROAD DIST. NO.	ILLINOIS	FED. AID PROJECT		
TRAFFIC SIGNAL PLANS				
CONTRACT NO.: 97372				

TRAFFIC SIGNAL LEGEND

- EXISTING SIGNAL HEAD
- EXISTING HANDHOLE
- EXISTING MAST ARM
- EXISTING CONTROLLER
- PROPOSED SIGNAL HEAD (SEE HIGHWAY STANDARD 880006)
- PROPOSED SIGNAL HEAD WITH BACKPLATE (SEE HIGHWAY STANDARD 880006)
- PROPOSED HANDHOLE (SEE HIGHWAY STANDARD 814001)
- PROPOSED DOUBLE HANDHOLE (SEE HIGHWAY STANDARD 814006)
- PROPOSED DETECTOR LOOP (SEE HIGHWAY STANDARDS 886001 & 886006)
- PROPOSED DETECTOR LOOP (SEE HIGHWAY STANDARDS 886001 & 886006)
- PROPOSED CONDUIT: "T" TRENCH, "P" PUSHED, SIZE SPECIFIED
- PVCC POLYVINYL CHLORIDE CONDUIT
- GSC GALVANIZED STEEL CONDUIT
- PROPOSED SIGN
- PROPOSED MAST ARM (LENGTH SPECIFIED) (SEE HIGHWAY STANDARD 877001 & 878001)
- SERVICE INSTALLATION (SEE HIGHWAY STANDARD 805001 & SPECIAL PROVISIONS)
- PROPOSED CONTROLLER

BY	DATE
FINAL SURVEYED	
SURVEY PLOTTED	
NOTE BOOK TEMPLATE	
AREAS CHECKED	
NO.	

BY	DATE
ORIGINAL SURVEYED	
SURVEY PLOTTED	
NOTE BOOK TEMPLATE	
AREAS CHECKED	
NO.	

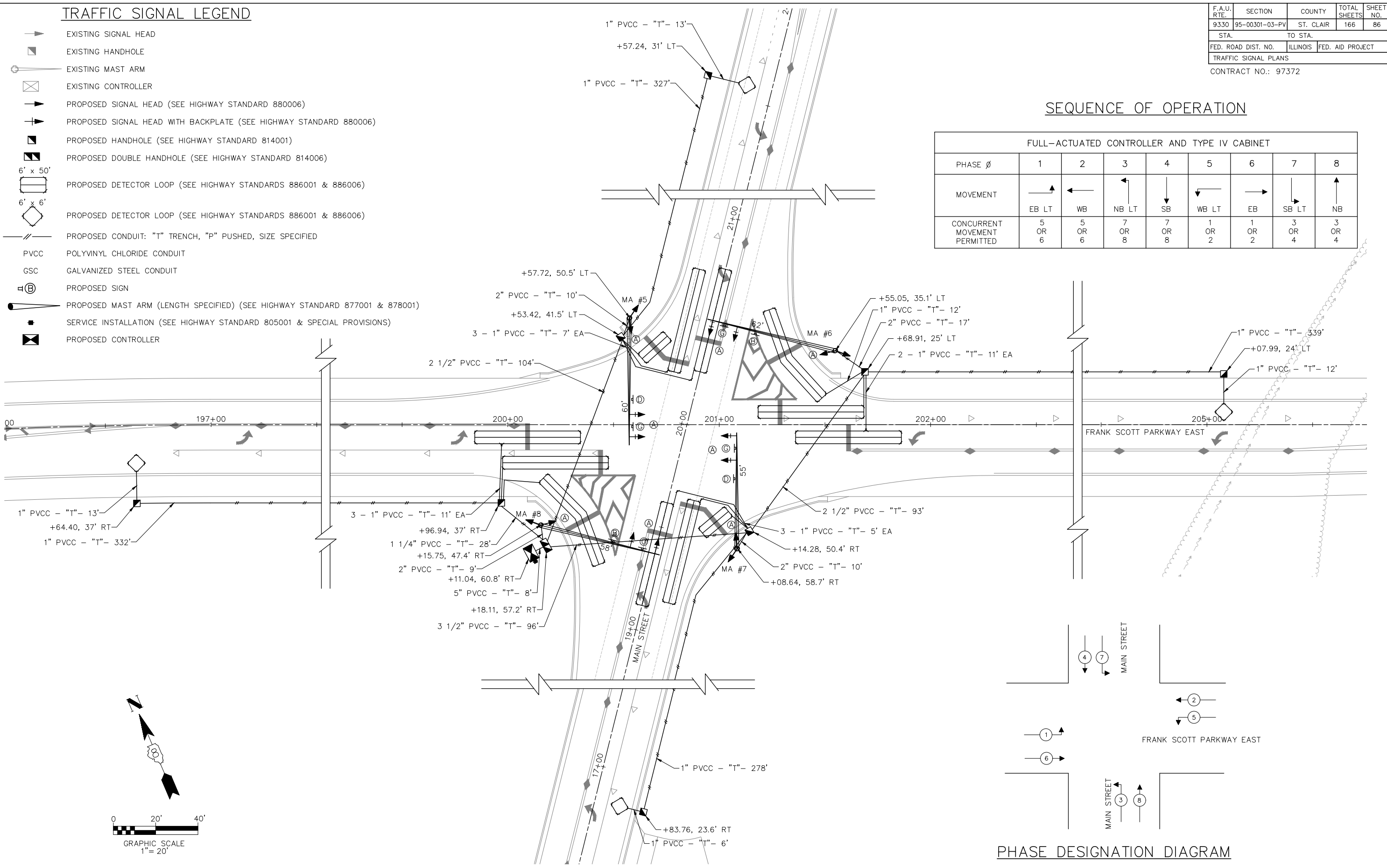

SEQUENCE OF OPERATION

FULL-ACTUATED CONTROLLER AND TYPE IV CABINET								
PHASE ϕ	1	2	3	4	5	6	7	8
MOVEMENT	EB LT	WB	NB LT	SB	WB LT	EB	SB LT	NB
CONCURRENT MOVEMENT PERMITTED	5 OR 6	5 OR 6	7 OR 8	7 OR 8	1 OR 2	1 OR 2	3 OR 4	3 OR 4

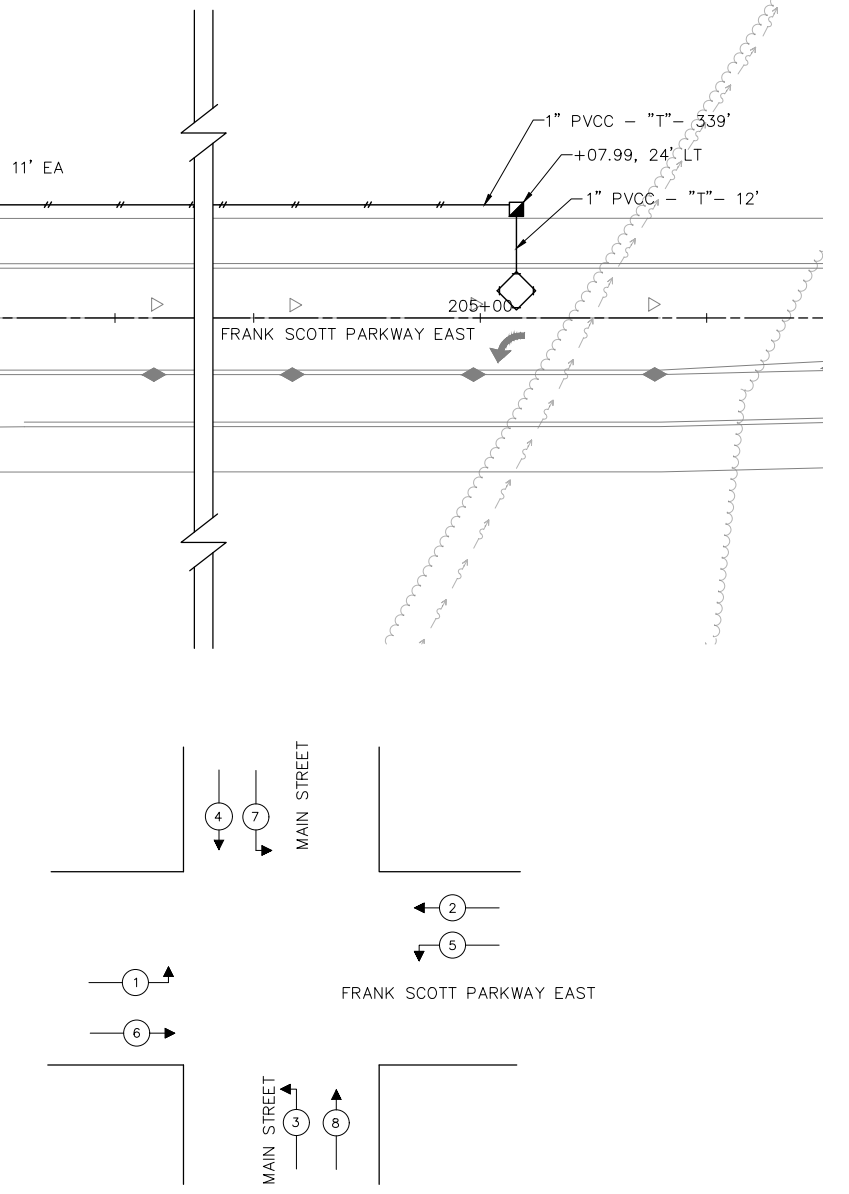

PHASE DESIGNATION DIAGRAM

F.A.U. RTE.	SECTION	COUNTY	TOTAL SHEETS	SHEET NO.
9330	95-00301-03-PV	ST. CLAIR	166	87
STA.		TO STA.		
FED. ROAD DIST. NO.		ILLINOIS FED. AID PROJECT		
TRAFFIC SIGNAL PLANS				

CONTRACT NO.: 97372

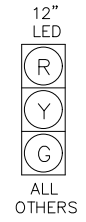
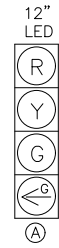

TRAFFIC SIGNAL FACES



NOT TO SCALE

CABLE DIAGRAM LEGEND

- ELECTRIC CABLE IN CONDUIT
- S CABLE SPLICE (SEE GENERAL NOTES)
- 2/C INDICATES NUMBER OF CONDUCTORS IN CABLE
- C.D. CALL DELAY (SEE GENERAL NOTES)
- C.C.O. CALL CARRY OVER (SEE GENERAL NOTES)
- NO. 6 INDICATES AMERICAN WIRE (AWG) SIZE 6
- #6 LOOP DETECTOR NUMBER
- EXISTING SERVICE INSTALLATION

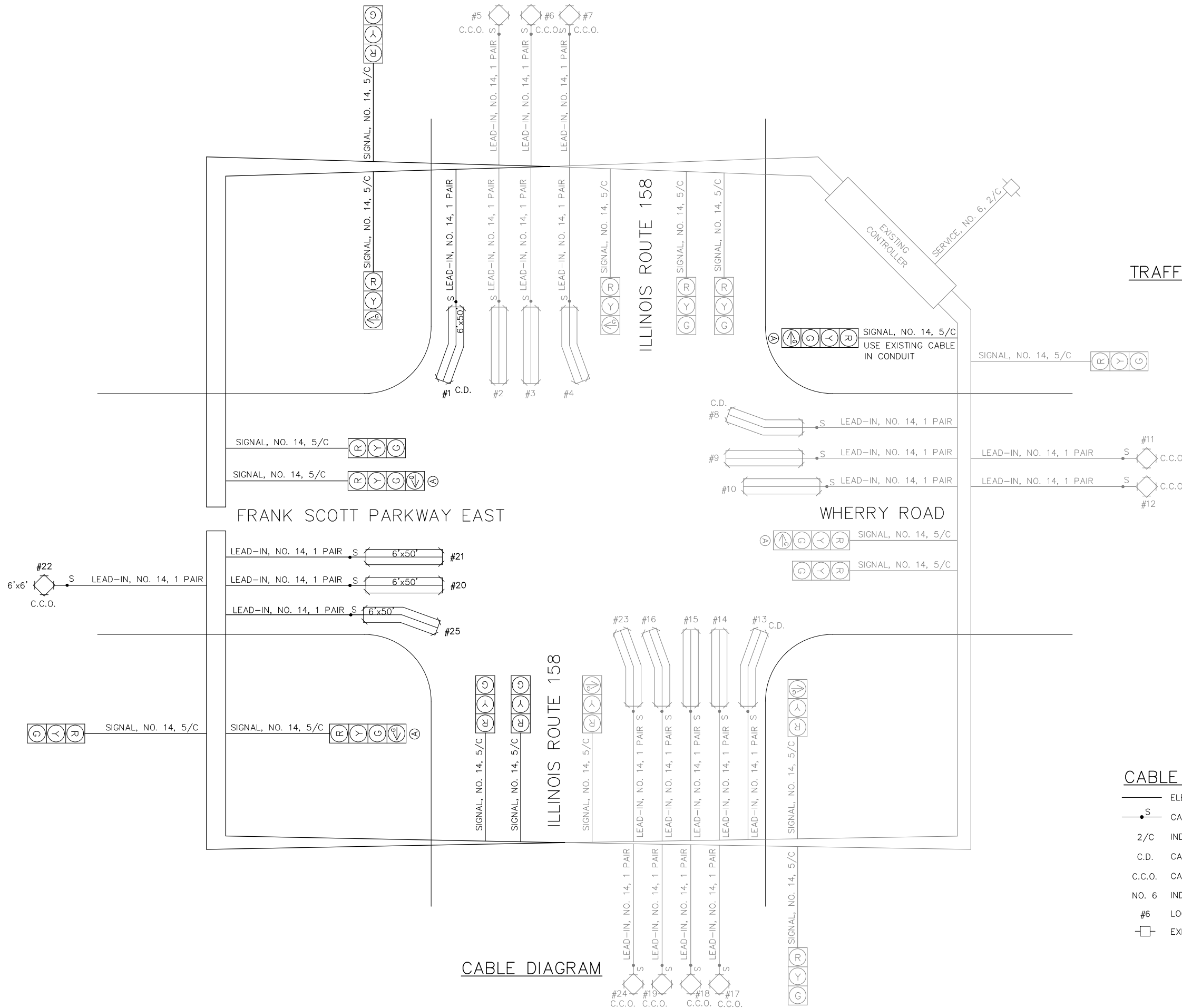

CABLE DIAGRAM

FINAL SURVEY PLOTTED	BY	DATE
NOTE BOOK TEMPLATE AREAS CHECKED		
NO.		

ORIGINAL SURVEY PLOTTED	BY	DATE
NOTE BOOK TEMPLATE AREAS CHECKED		
NO.		

F.A.U. RTE.	SECTION	COUNTY	TOTAL SHEETS	SHEET NO.
9330	95-00301-03-PV	ST. CLAIR	166	88
STA.	TO STA.			
FED. ROAD DIST. NO.	ILLINOIS	FED. AID PROJECT		
TRAFFIC SIGNAL PLANS				
CONTRACT NO.: 97372				

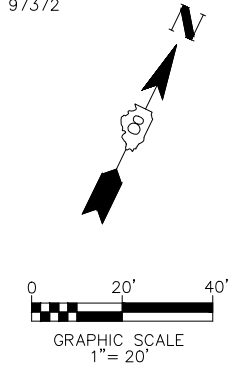

TRAFFIC SIGNAL LEGEND

- EXISTING SIGNAL HEAD
- EXISTING HANDHOLE
- EXISTING MAST ARM
- EXISTING CONTROLLER
- PROPOSED SIGNAL HEAD (SEE HIGHWAY STANDARD 880006)
- PROPOSED SIGNAL HEAD WITH BACKPLATE (SEE HIGHWAY STANDARD 880006)
- PROPOSED HANDHOLE (SEE HIGHWAY STANDARD 814001)
- PROPOSED DOUBLE HANDHOLE (SEE HIGHWAY STANDARD 814006)
- PROPOSED DETECTOR LOOP (SEE HIGHWAY STANDARDS 886001 & 886006)
- PROPOSED DETECTOR LOOP (SEE HIGHWAY STANDARDS 886001 & 886006)
- PROPOSED CONDUIT: "T" TRENCH, "P" PUSHED, SIZE SPECIFIED
- PVCC POLYVINYL CHLORIDE CONDUIT
- GSC GALVANIZED STEEL CONDUIT
- PROPOSED SIGN
- PROPOSED MAST ARM (LENGTH SPECIFIED) (SEE HIGHWAY STANDARD 877001 & 878001)
- SERVICE INSTALLATION (SEE HIGHWAY STANDARD 805001 & SPECIAL PROVISIONS)
- PROPOSED CONTROLLER

BY	DATE
FINAL SURVEYED	
SURVEY PLOTTED	
NOTE BOOK TEMPLATE	
AREAS CHECKED	
NO.	

BY	DATE
ORIGINAL SURVEYED	
SURVEY PLOTTED	
NOTE BOOK TEMPLATE	
AREAS CHECKED	
NO.	

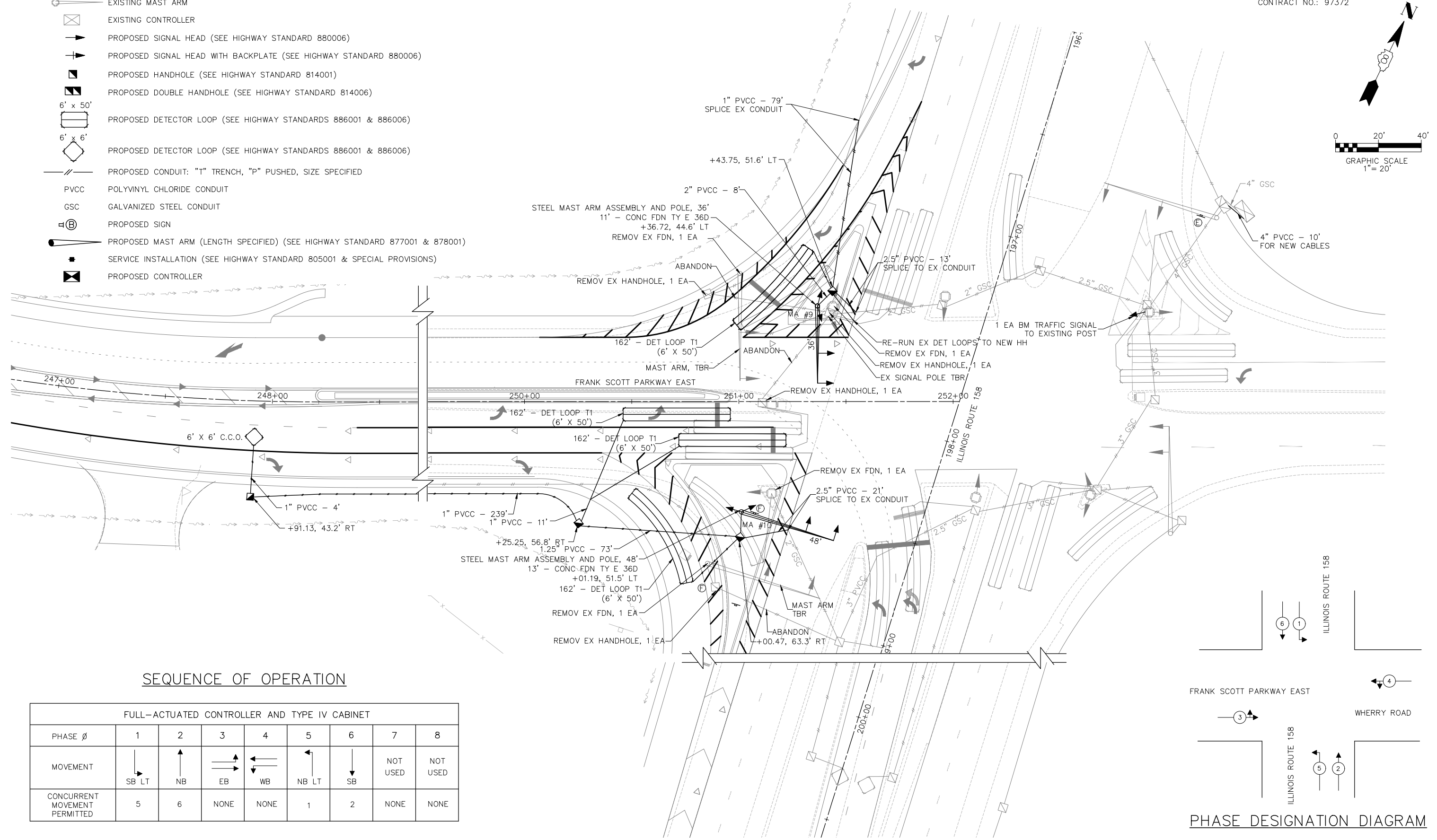

SEQUENCE OF OPERATION

FULL-ACTUATED CONTROLLER AND TYPE IV CABINET								
PHASE Ø	1	2	3	4	5	6	7	8
MOVEMENT	SB LT	NB	EB	WB	NB LT	SB	NOT USED	NOT USED
CONCURRENT MOVEMENT PERMITTED	5	6	NONE	NONE	1	2	NONE	NONE

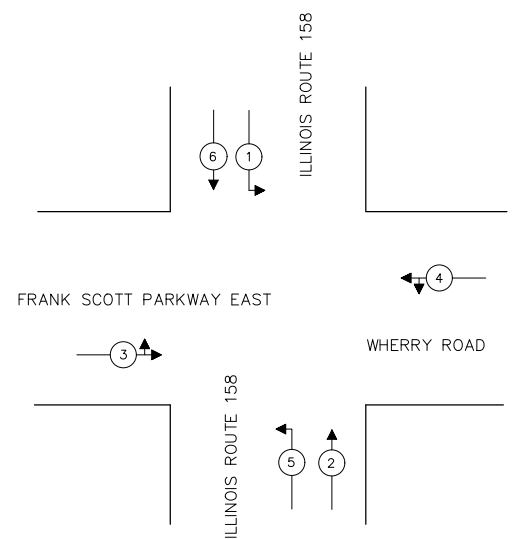

PHASE DESIGNATION DIAGRAM

F.A.U. RTE.	SECTION	COUNTY	TOTAL SHEETS	SHEET NO.
9330	95-00301-03-PV	ST. CLAIR	166	89
STA.		TO STA.		
FED. ROAD DIST. NO.		ILLINOIS	FED. AID PROJECT	
TRAFFIC SIGNAL PLANS				

CONTRACT NO.: 97372

TRAFFIC SIGNAL QUANTITIES

CODE NO.	ITEM	ABBREVIATED ITEM NAME	UNIT	TOTAL QUANTITIES	INTERSECTION		
					CROSS STREET	MAIN STREET	IL RTE 158
81028170	UNDERGROUND CONDUIT, GALVANIZED STEEL, 1" DIA.	UNDRGRD C GALVS 1	FOOT	20	10	10	
81028190	UNDERGROUND CONDUIT, GALVANIZED STEEL, 1 1/2" DIA.	UNDRGRD C GALVS 1 1/2	FOOT	20	10	10	
81028220	UNDERGROUND CONDUIT, GALVANIZED STEEL, 3" DIA.	UNDRGRD C GALVS 3	FOOT	74	74		
81028230	UNDERGROUND CONDUIT, GALVANIZED STEEL, 3 1/2" DIA.	UNDRGRD C GALVS 3 1/2	FOOT	98	98		
81028320	UNDERGROUND CONDUIT, PVC, 1" DIA.	UNDRGRD C PVC 1	FOOT	3,272	1,516	1,423	333
81028330	UNDERGROUND CONDUIT, PVC, 1 1/4" DIA.	UNDRGRD C PVC 1 1/4	FOOT	101		28	73
81028340	UNDERGROUND CONDUIT, PVC, 1 1/2" DIA.	UNDRGRD C PVC 1 1/2	FOOT	133	105	28	
81028350	UNDERGROUND CONDUIT, PVC, 2" DIA.	UNDRGRD C PVC 2	FOOT	64	10	46	8
81028360	UNDERGROUND CONDUIT, PVC, 2 1/2" DIA.	UNDRGRD C PVC 2 1/2	FOOT	383	152	197	34
81028370	UNDERGROUND CONDUIT, PVC, 3" DIA.	UNDRGRD C PVC 3	FOOT	71	29		42
81028380	UNDERGROUND CONDUIT, PVC, 3 1/2" DIA.	UNDRGRD C PVC 3 1/2	FOOT	130	34	96	
81028390	UNDERGROUND CONDUIT, PVC, 4" DIA.	UNDRGRD C PVC 4	FOOT	10			10
81028400	UNDERGROUND CONDUIT, PVC, 5" DIA.	UNDRGRD C PVC 5	FOOT	16	8	8	
81400700	HANDHOLE, PORTLAND CEMENT CONCRETE	HANDHOLE PCC	EACH	22	10	8	4
81400720	DOUBLE HANDHOLE, PORTLAND CEMENT CONCRETE	DBL HANDHOLE PCC	EACH	2	1	1	
85000200	MAINTENANCE OF EXISTING TRAFFIC SIGNAL INSTALLATION	MAIN EX TR SIG INSTAL	EACH	3	1	1	1
85700200	FULL-ACTUATED CONTROLLER AND TYPE IV CABINET	FAC T4 CAB	EACH	2	1	1	
87301245	ELECTRIC CABLE IN CONDUIT, SIGNAL NO. 14 5C	ELCBL C SIGNAL 14 5C	FOOT	6,885	2,253	1,424	3,208
87301255	ELECTRIC CABLE IN CONDUIT, SIGNAL NO. 14 7C	ELCBL C SIGNAL 14 7C	FOOT	3,136	1,664	1,472	
87301305	ELECTRIC CABLE IN CONDUIT, LEAD-IN, NO. 14 1 PAIR	ELCBL C LEAD 14 1PR	FOOT	10,575	4,483	3,635	2,457
87301805	ELECTRIC CABLE IN CONDUIT, SERVICE, NO. 6 2 C	ELCBL C SERV 6 2C	FOOT	20	10	10	
87700220	STEEL MAST ARM ASSEMBLY AND POLE, 36 FT.	S MAA & P 36	EACH	1			1
87700280	STEEL MAST ARM ASSEMBLY AND POLE, 48 FT.	S MAA & P 48	EACH	1			1
87700320	STEEL MAST ARM ASSEMBLY AND POLE, 55 FT.	S MAA & P 55	EACH	2	1	1	
87700340	STEEL MAST ARM ASSEMBLY AND POLE, 58 FT.	S MAA & P 58	EACH	1	1		
87700400	STEEL MAST ARM ASSEMBLY AND POLE, 60 FT.	S MAA & P 60	EACH	2	1	1	
87700404	STEEL MAST ARM ASSEMBLY AND POLE, 62 FT.	S MAA & P 62	EACH	3	1	2	
87800200	CONCRETE FOUNDATION, TYPE D	CONC FDN TY D	FOOT	6	3	3	
87800415	CONCRETE FOUNDATION, TYPE E 36-INCH DIAMETER	CONC FDN TY E 36D	FOOT	152	67	61	24
88040070	SIGNAL HEAD, POLYCARBONATE, LED, 1-FACE, 3-SECTION, BRACKET MOUNTED	SH P LED 1F 3S BM	EACH	11	4	4	3
88040090	SIGNAL HEAD, POLYCARBONATE, LED, 1-FACE, 3-SECTION, MAST ARM MOUNTED	SH P LED 1F 3S MAM	EACH	14	7	4	3
88040110	SIGNAL HEAD, POLYCARBONATE, LED, 1-FACE, 4-SECTION, BRACKET MOUNTED	SH P LED 1F 4S BM	EACH	1			2
88040120	SIGNAL HEAD, POLYCARBONATE, LED, 1-FACE, 4-SECTION, MAST ARM MOUNTED	SH P LED 1F 4S MAM	EACH	1			1
88040150	SIGNAL HEAD, POLYCARBONATE, LED, 1-FACE, 5-SECTION, BRACKET MOUNTED	SH P LED 1F 5S BM	EACH	8	4	4	
88040160	SIGNAL HEAD, POLYCARBONATE, LED, 1-FACE, 5-SECTION, MAST ARM MOUNTED	SH P LED 1F 5S MAM	EACH	8	4	4	
88200100	TRAFFIC SIGNAL BACKPLATE	TS BACKPLATE	EACH	23	11	8	4
88500100	INDUCTIVE LOOP DETECTOR	INDUCTIVE LOOP DETECT	EACH	37	16	16	5
88600100	DETECTOR LOOP, TYPE I	DET LOOP T1	FOOT	5,452	2,426	2,167	859
89502375	REMOVE EXISTING TRAFFIC SIGNAL EQUIPMENT	REMOV EX TS EQUIP	EACH	2	1		1
89502380	REMOVE EXISTING HANDHOLE	REMOV EX HANDHOLE	EACH	10	6		4
89502385	REMOVE EXISTING CONCRETE FOUNDATION	REMOV EX CONC FDN	EACH	9	5		4
X8050115	SERVICE INSTALLATION, TYPE A (MODIFIED)	SERV INSTALL TYA	EACH	2	1	1	

F.A.U. RTE.	SECTION	COUNTY	TOTAL SHEETS	SHEET NO.
9330	95-00301-03-PV	ST. CLAIR	166	90
STA.	TO STA.			
FED. ROAD DIST. NO.	ILLINOIS	FED. AID PROJECT		
DETAILS				

CONTRACT NO.: 97372

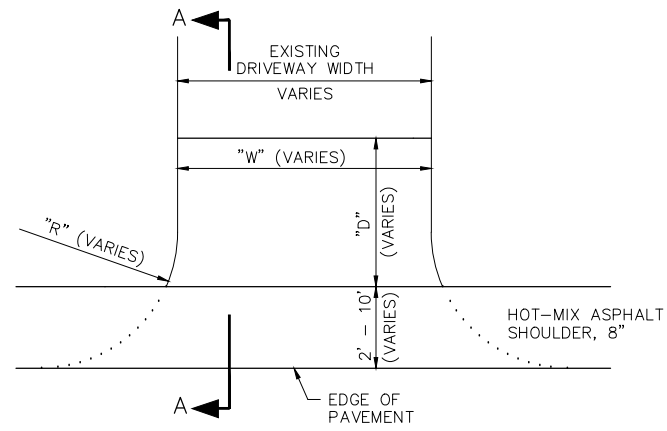

**TYPICAL ENTRANCE DETAIL
ALONG HOT-MIX ASPHALT SHOULDERS**
(NOT TO SCALE)

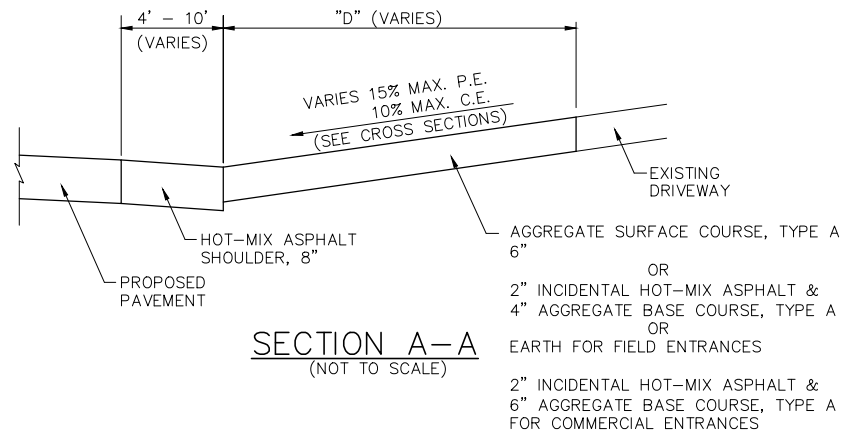

SECTION A-A
(NOT TO SCALE)

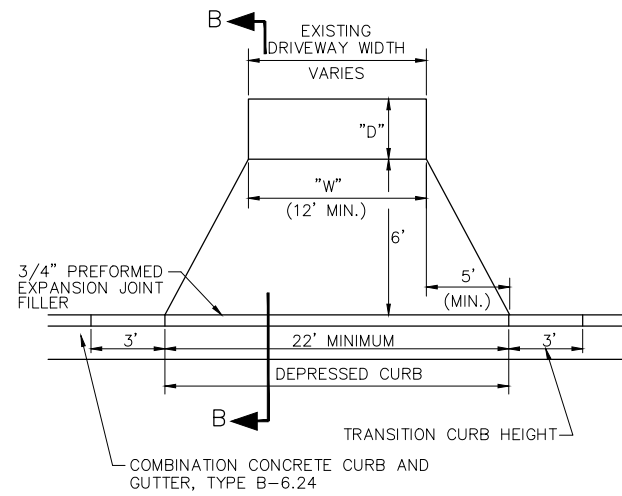

**TYPICAL ENTRANCE DETAIL
ALONG CURB & GUTTER**
(NOT TO SCALE)

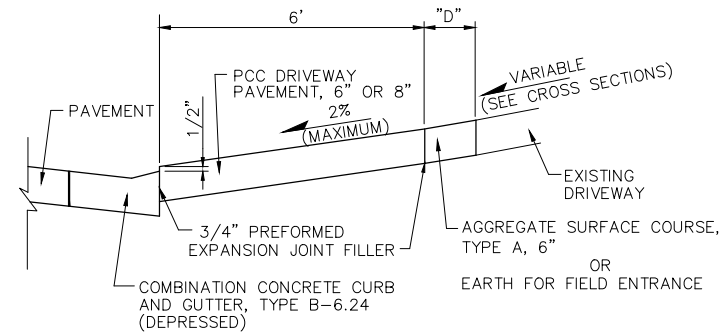

SECTION B-B
(NOT TO SCALE)

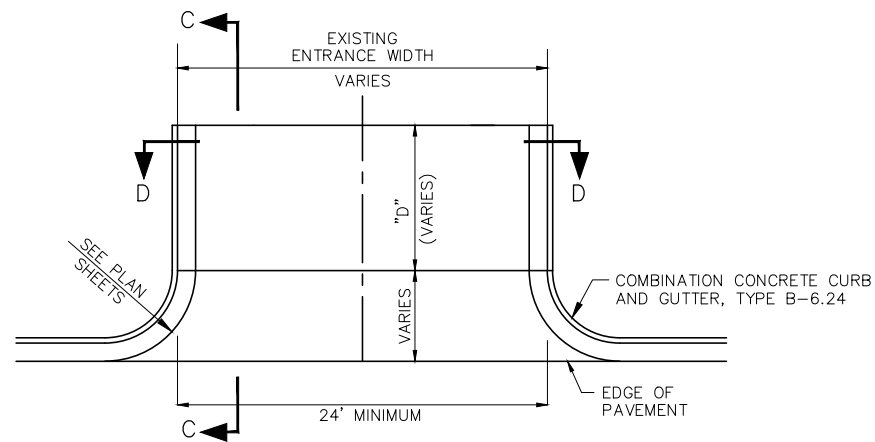

TYPICAL STREET DETAIL
NOT TO SCALE
JULIUS DRIVE @ STA. 14+63 RT (MAIN STREET)

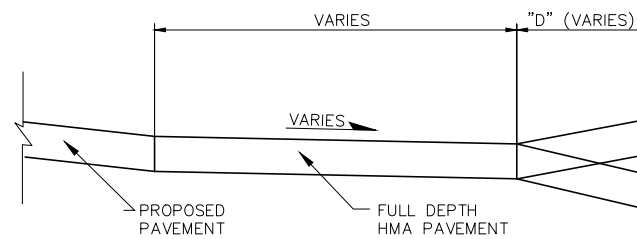

SECTION C-C
NOT TO SCALE

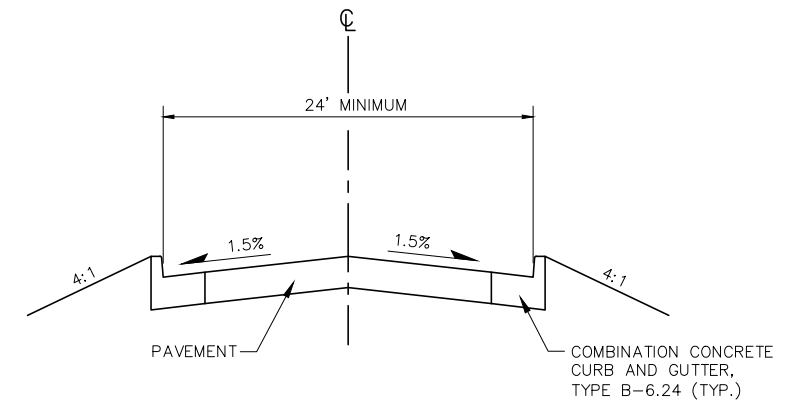

SECTION D-D
NOT TO SCALE

F.A.U. RTE.	SECTION	COUNTY	TOTAL SHEETS	SHEET NO.
9330	95-00301-03-PV	ST. CLAIR	166	91
STA.	TO STA.			
FED. ROAD DIST. NO.	ILLINOIS	FED. AID PROJECT		
DETAILS				

CONTRACT NO.: 97372

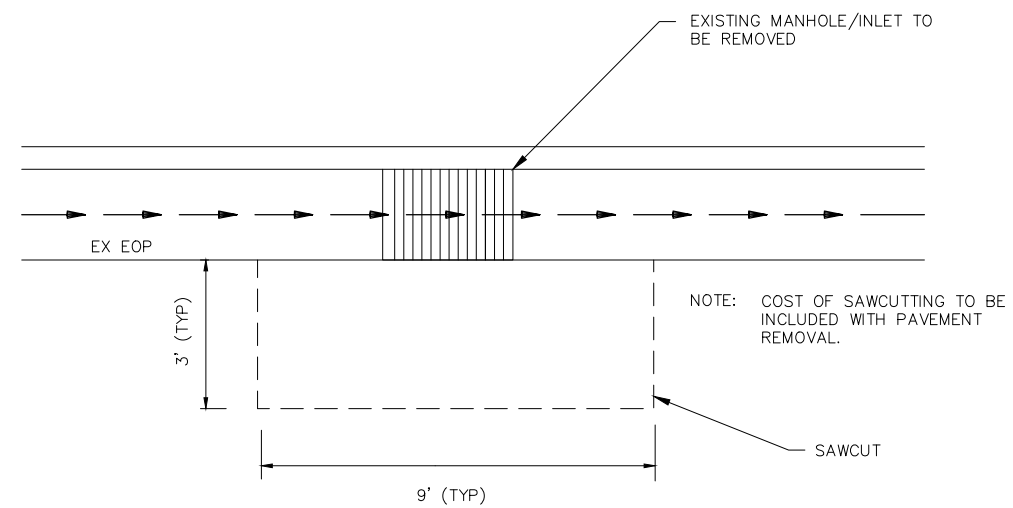

MAIN STREET PAVEMENT REMOVAL DETAIL
(NOT TO SCALE)

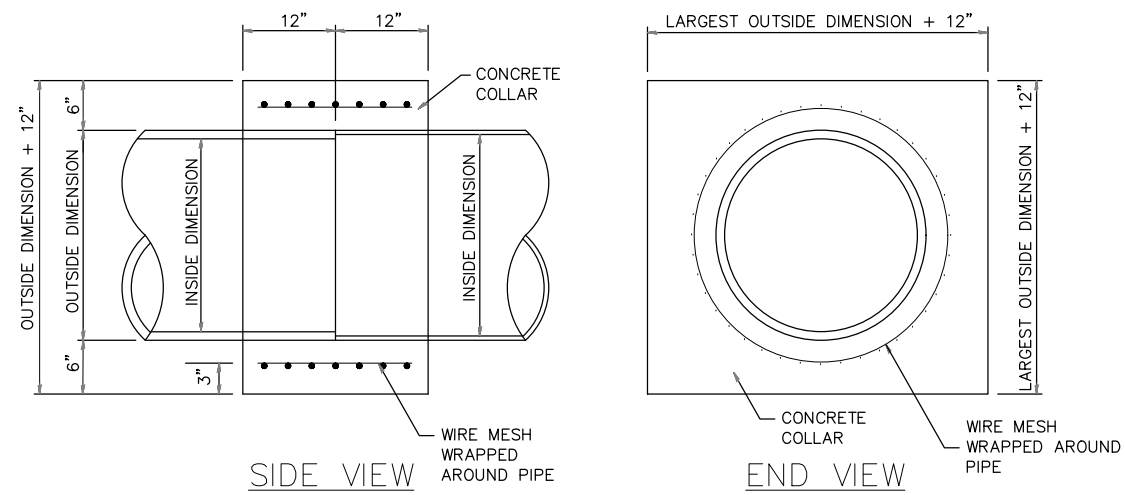

- NOTES:**
1. CLASS SI CONCRETE SHALL BE USED THROUGHOUT.
 2. WHEN CONCRETE COLLARS ARE USED TO CONNECT PIPES OF DIFFERENT OUTSIDE DIMENSIONS, THE CONCRETE COLLAR SHALL BE FORMED USING THE LARGEST OUTSIDE DIMENSION. (SEE END VIEW)
 3. WIRE MESH SHALL WEIGHT NOT LESS THAN 58 POUNDS PER 100 SQ. FT.

CONCRETE COLLAR DETAIL
(NOT TO SCALE)

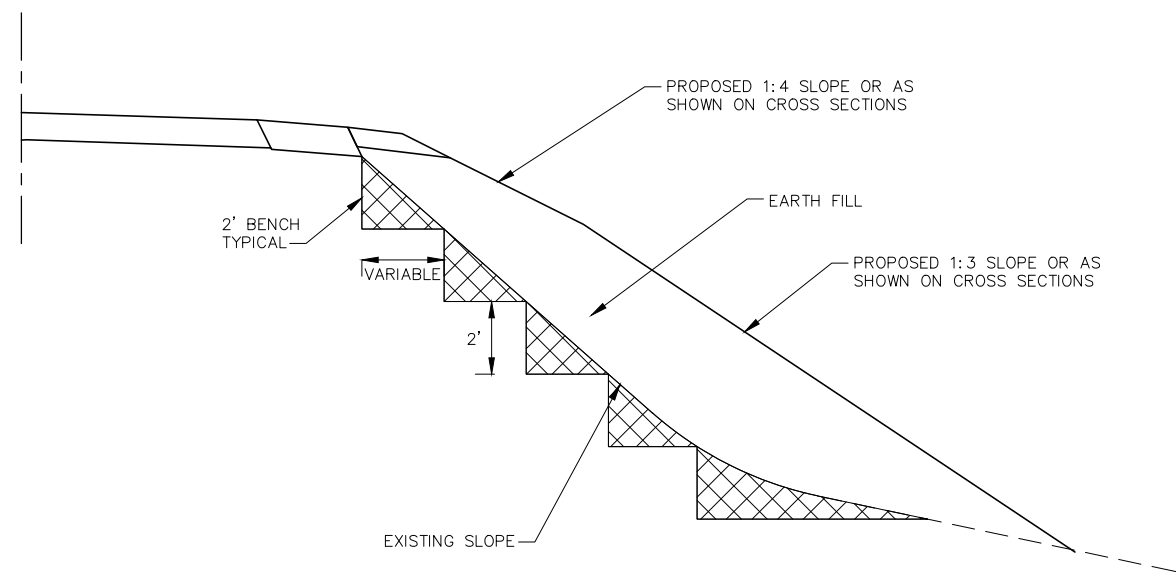

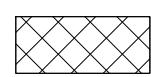
 MATERIAL TO BE REMOVED AND REPLACED IN THE EMBANKMENT IN ACCORDANCE WITH ARTICLE 205.04 OF THE STANDARD SPECIFICATIONS. COST TO BE INCLUDED IN THE VARIOUS ITEMS OF EXCAVATION AND NO ADDITIONAL COMPENSATION WILL BE ALLOWED.

BENCHING DETAIL

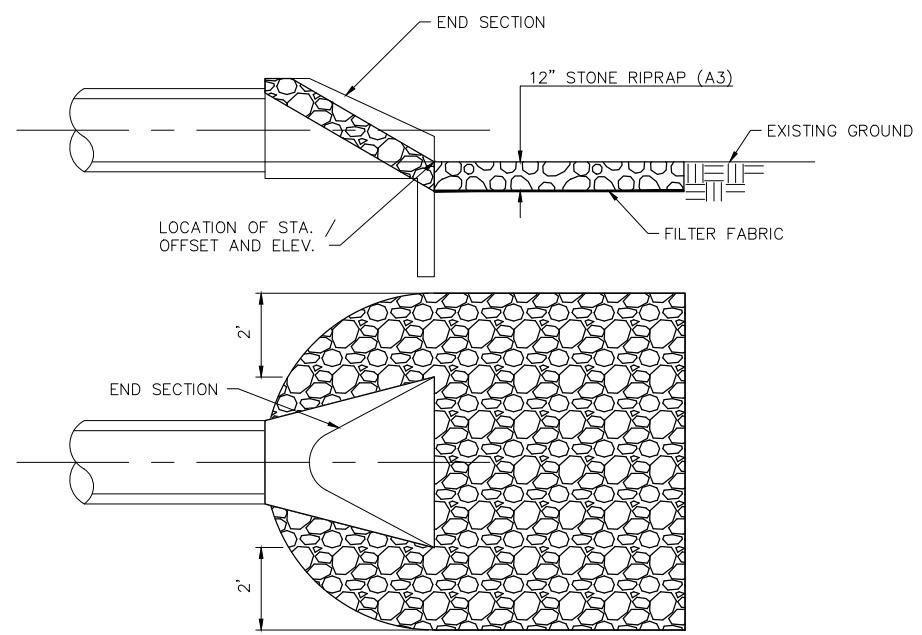

SEE PLAN FOR LENGTH OF PROTECTION

TYPICAL RIPRAP DETAIL
(NOT TO SCALE)

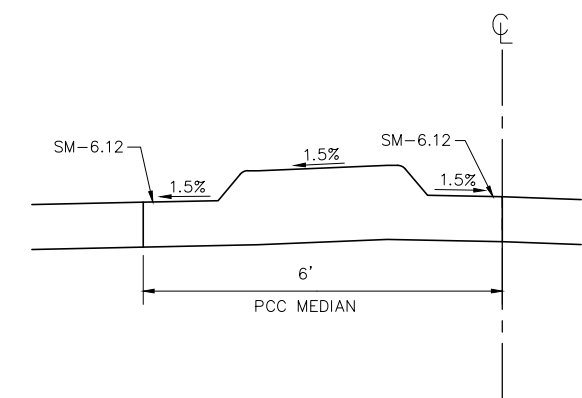

SOLID MEDIAN DETAIL
(NOT TO SCALE)
STA 248+23.12 TO STA 250+94.13

F.A.U. RTE.	SECTION	COUNTY	TOTAL SHEETS	SHEET NO.
9330	95-00301-03-PV	ST. CLAIR	166	92
STA.	TO STA.			
FED. ROAD DIST. NO.	ILLINOIS	FED. AID PROJECT		
DETAILS				

CONTRACT NO.: 97372

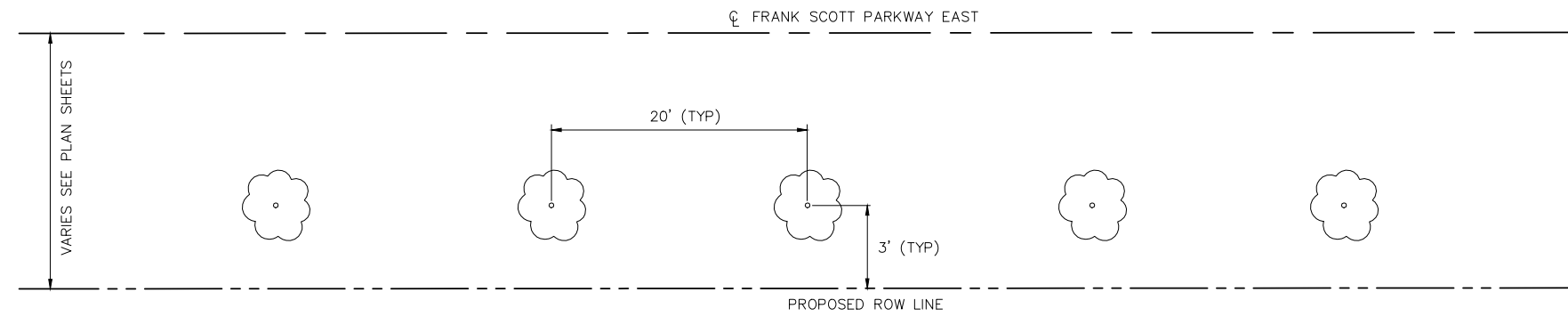

TREE REPLACEMENT ALONG RIGHT-OF-WAY LINE
(NOT TO SCALE)

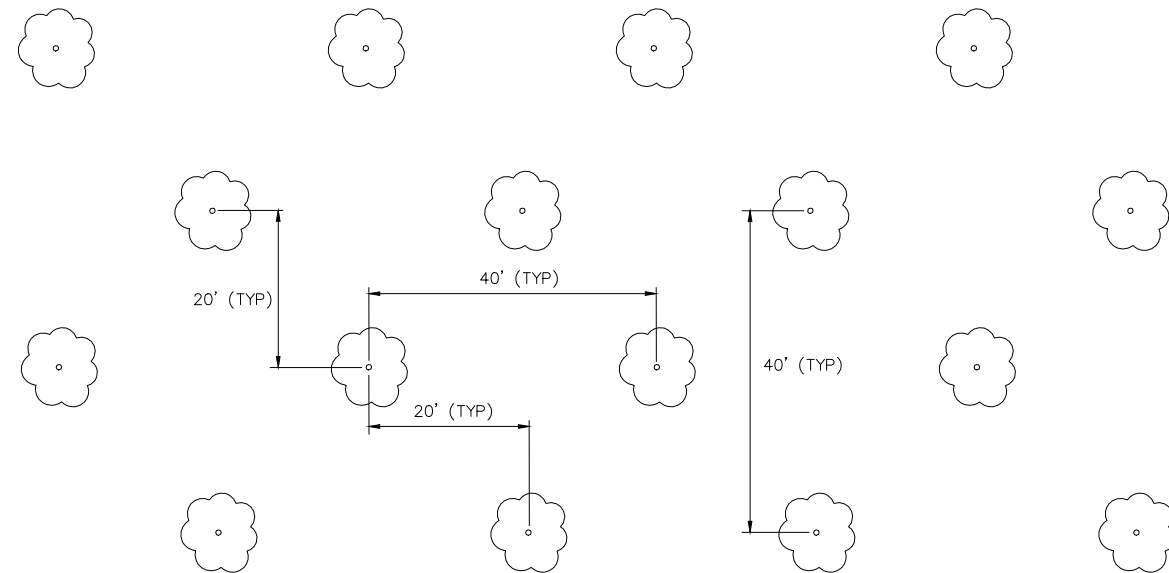

AREA TREE REPLACEMENT
(NOT TO SCALE)

NOTES: 1. BELOW IS A LIST OF ACCEPTABLE TREE SPECIES. SEE SCHEDULE FOR ADDITIONAL DETAILS.

- SWAMP WHITE OAK (QUERCUS BICOLOR)
- PECAN (CARYA ILLINOINENSIS)
- PIN OAK (QUERCUS PALUSTRIS)
- SHELLBARK HICKORY (CARYA LACINIOSA)
- BUR OAK (QUERCUS MACROCARPA)
- SHAGBARK HICKORY (CARYA OVATA)
- SYCAMORE (PLATANUS OCCIDENTALIS)

2. TREES THAT ARE NOT SCHEDULED TO BE PLANTED WITHIN THE PROJECT LIMITS SHALL BE PLANTED AT AN ACCEPTABLE OFFSITE LOCATION TO BE APPROVED BY ST. CLAIR COUNTY.
3. TREE SPECIES AND LOCATIONS SHALL BE PLANTED AS DIRECTED BY THE ENGINEER.
4. TREES 3" OR GREATER IN DIAMETER AT BREAST HEIGHT SHALL NOT BE CLEARED FROM APRIL 1 THROUGH SEPTEMBER 30 OF ANY GIVEN YEAR.
5. ONLY TREES THAT HAVE BEEN CLEARED MARKED IN THE FIELD, BY THE ENGINEER, SHALL BE REMOVED.
6. 158 TREES WILL BE PLANTED IN NEARBY FOLEY PARK AND SHALL BE PLANTED AND MAINTAINED IN THE SAME MANNER AS TREES PLANTED ON SITE.

TREE MITIGATION

STATION	STATION	T-QUERCUS BICOL 2 (EACH)	T-CARYA ILLINOEN 2 (EACH)	T-QUERCUS PALUS 2 (EACH)	T-CARYA LACINIO CG 3G (EACH)	T-QUERCUS MACR 2 (EACH)	T-CARYA OVATA 2 (EACH)	T-PLATANUS OCC 2 (EACH)
FRANK SCOTT PARKWAY EAST								
164+89	252+00	124	124	123	123	123	123	123
OFFSITE LOCATION								
		27	27	27	26	26	26	26
TOTAL		151	151	150	149	149	149	149

Illinois Department of Transportation SOIL BORING LOG Page 1 of 1
 Date 02/28/06
 ROUTE Frank Scott Parkway East Extension DESCRIPTION Mast Arm Boring LOGGED BY SCI

SECTION LOCATION Shiloh
 COUNTY St. Clair DRILLING METHOD CME 750 w/CFA HAMMER TYPE Automatic

STRUCT. NO. _____ SURFACE WATER Elev. _____ ft
 Station _____ STREAM BED Elev. _____ ft

BORING NO. B-M8
 Station 200+35.2
 Offset 37.1 R/L
 Ground Surface Elev. 539.7 ft (R) (F) (B) (M) (N)

Groundwater Elev.: _____ ft
 First Encounter 528.7 ft
 Upon Completion _____ ft
 After _____ Hrs.

TOPSOIL - 2 inches
 Dark brown CLAY, A-7

3	1.8	27
3	1.3	28
3	0.3	30
2	1.2	28
3	1.3	28
3	1.8	27
4	9/15	
2	0.8	33
3	1.8	24

Boring terminated at 20.0 ft.

The Unconfined Compressive Strength (UCS) Failure Mode is Indicated by (B-Bulge, S-Shear, P-Penetrometer)
 AASHTO Classifications are based on visual classifications unless otherwise noted BBS, form 137 (Rev. 8-99)

Illinois Department of Transportation SOIL BORING LOG Page 1 of 1
 Date 02/27/06
 ROUTE Frank Scott Parkway East Extension DESCRIPTION Mast Arm Boring LOGGED BY SCI

SECTION LOCATION Shiloh
 COUNTY St. Clair DRILLING METHOD CME 750 w/CFA HAMMER TYPE Automatic

STRUCT. NO. _____ SURFACE WATER Elev. _____ ft
 Station _____ STREAM BED Elev. _____ ft

BORING NO. B-M4
 Station 191+33.7
 Offset 55.7 R/L
 Ground Surface Elev. 524.4 ft (R) (F) (B) (M) (N)

Groundwater Elev.: _____ ft
 First Encounter Not Obs.
 Upon Completion _____ ft
 After _____ Hrs.

Crushed Rock - 12 inches

Brown CLAY, A-7

Brown CLAYEY SILT, A-4

Brown SILTY CLAY, A-8

Brown CLAYEY SILT, A-4

Brown SILTY CLAY, A-8

Brown CLAYEY SILT, A-4

Brown SILTY CLAY, A-8

Brown CLAY, trace sand, A-7

Boring terminated at 20.0 ft.

The Unconfined Compressive Strength (UCS) Failure Mode is Indicated by (B-Bulge, S-Shear, P-Penetrometer)
 AASHTO Classifications are based on visual classifications unless otherwise noted BBS, form 137 (Rev. 8-99)

Illinois Department of Transportation SOIL BORING LOG Page 1 of 1
 Date 02/27/06
 ROUTE Frank Scott Parkway East Extension DESCRIPTION Mast Arm Boring LOGGED BY SCI

SECTION LOCATION Shiloh
 COUNTY St. Clair DRILLING METHOD CME 750 w/CFA HAMMER TYPE Automatic

STRUCT. NO. _____ SURFACE WATER Elev. _____ ft
 Station _____ STREAM BED Elev. _____ ft

BORING NO. B-M2
 Station 162+67.85
 Offset 42.1 R/L
 Ground Surface Elev. 527.1 ft (R) (F) (B) (M) (N)

Groundwater Elev.: _____ ft
 First Encounter Not Obs.
 Upon Completion _____ ft
 After _____ Hrs.

TOPSOIL - 0.5 inch
 Brown CLAY, A-7

Brown SILTY CLAY, A-8

Brown CLAYEY SILT, A-4

Brown SILTY CLAY, A-8

Brown CLAY, trace sand, A-7

Boring terminated at 20.0 ft.

The Unconfined Compressive Strength (UCS) Failure Mode is Indicated by (B-Bulge, S-Shear, P-Penetrometer)
 AASHTO Classifications are based on visual classifications unless otherwise noted BBS, form 137 (Rev. 8-99)

Illinois Department of Transportation SOIL BORING LOG Page 1 of 1
 Date 02/27/06
 ROUTE Frank Scott Parkway East Extension DESCRIPTION Mast Arm Boring LOGGED BY SCI

SECTION LOCATION Shiloh
 COUNTY St. Clair DRILLING METHOD CME 750 w/CFA HAMMER TYPE Automatic

STRUCT. NO. _____ SURFACE WATER Elev. _____ ft
 Station _____ STREAM BED Elev. _____ ft

BORING NO. B-M3
 Station 161+49.45
 Offset 87.2 R/L
 Ground Surface Elev. 528.9 ft (R) (F) (B) (M) (N)

Groundwater Elev.: _____ ft
 First Encounter Not Obs.
 Upon Completion _____ ft
 After _____ Hrs.

TOPSOIL - 1 inch
 Brown CLAY, A-7

Brown SILTY CLAY, A-8

Brown CLAYEY SILT, A-4

Brown SILTY CLAY, trace sand, A-8

Boring terminated at 20.0 ft.

The Unconfined Compressive Strength (UCS) Failure Mode is Indicated by (B-Bulge, S-Shear, P-Penetrometer)
 AASHTO Classifications are based on visual classifications unless otherwise noted BBS, form 137 (Rev. 8-99)

Illinois Department of Transportation SOIL BORING LOG Page 1 of 1
 Date 02/28/06
 ROUTE Frank Scott Parkway East Extension DESCRIPTION Mast Arm Boring LOGGED BY SCI

SECTION LOCATION Shiloh
 COUNTY St. Clair DRILLING METHOD CME 750 w/CFA HAMMER TYPE Automatic

STRUCT. NO. _____ SURFACE WATER Elev. _____ ft
 Station _____ STREAM BED Elev. _____ ft

BORING NO. B-M5
 Station 201+45.2
 Offset 57.8 R/L
 Ground Surface Elev. 537.8 ft (R) (F) (B) (M) (N)

Groundwater Elev.: _____ ft
 First Encounter 524.8 ft
 Upon Completion _____ ft
 After _____ Hrs.

TOPSOIL - 2 inches
 Brown CLAY, A-7

Brown SILTY CLAY, A-8

Brown SILT, A-4

Brown SILTY CLAY, A-8

Brown CLAY, A-7

Boring terminated at 20.0 ft.

The Unconfined Compressive Strength (UCS) Failure Mode is Indicated by (B-Bulge, S-Shear, P-Penetrometer)
 AASHTO Classifications are based on visual classifications unless otherwise noted BBS, form 137 (Rev. 8-99)

Illinois Department of Transportation SOIL BORING LOG Page 1 of 1
 Date 02/27/06
 ROUTE Frank Scott Parkway East Extension DESCRIPTION Mast Arm Boring LOGGED BY SCI

SECTION LOCATION Shiloh
 COUNTY St. Clair DRILLING METHOD CME 750 w/CFA HAMMER TYPE Automatic

STRUCT. NO. _____ SURFACE WATER Elev. _____ ft
 Station _____ STREAM BED Elev. _____ ft

BORING NO. B-M1
 Station 162+20.8
 Offset 72.8 R/L
 Ground Surface Elev. 528.9 ft (R) (F) (B) (M) (N)

Groundwater Elev.: _____ ft
 First Encounter Not Obs.
 Upon Completion _____ ft
 After _____ Hrs.

TOPSOIL - 0.5 inch
 Brown CLAY, A-7

Brown SILTY CLAY, A-8

Brown CLAYEY SILT, A-4

Brown SILTY CLAY, A-8

Brown CLAY, some sand, some gravel, A-7

Boring terminated at 20.0 ft.

The Unconfined Compressive Strength (UCS) Failure Mode is Indicated by (B-Bulge, S-Shear, P-Penetrometer)
 AASHTO Classifications are based on visual classifications unless otherwise noted BBS, form 137 (Rev. 8-99)

Illinois Department of Transportation SOIL BORING LOG Page 1 of 1
 Date 02/28/06
 ROUTE Frank Scott Parkway East Extension DESCRIPTION Mast Arm Boring LOGGED BY SCI

SECTION LOCATION Shiloh
 COUNTY St. Clair DRILLING METHOD CME 750 w/CFA HAMMER TYPE Automatic

STRUCT. NO. _____ SURFACE WATER Elev. _____ ft
 Station _____ STREAM BED Elev. _____ ft

BORING NO. B-M6
 Station 201+23.8
 Offset 48.8 R/L
 Ground Surface Elev. 537.8 ft (R) (F) (B) (M) (N)

Groundwater Elev.: _____ ft
 First Encounter 532.2 ft
 Upon Completion _____ ft
 After _____ Hrs.

TOPSOIL - 2 inches
 Brown SILTY CLAY, A-7

Brown CLAY, A-7

Brown CLAYEY SILT, A-4

Brown SILT, A-4

Gray CLAY, A-7

Boring terminated at 20.0 ft.

The Unconfined Compressive Strength (UCS) Failure Mode is Indicated by (B-Bulge, S-Shear, P-Penetrometer)
 AASHTO Classifications are based on visual classifications unless otherwise noted BBS, form 137 (Rev. 8-99)

Illinois Department of Transportation SOIL BORING LOG Page 1 of 1
 Date 02/28/06
 ROUTE Frank Scott Parkway East Extension DESCRIPTION Mast Arm Boring LOGGED BY SCI

SECTION LOCATION Shiloh
 COUNTY St. Clair DRILLING METHOD CME 750 w/CFA HAMMER TYPE Automatic

STRUCT. NO. _____ SURFACE WATER Elev. _____ ft
 Station _____ STREAM BED Elev. _____ ft

BORING NO. B-M7
 Station 200+14.4
 Offset 52.0 R/L
 Ground Surface Elev. 537.8 ft (R) (F) (B) (M) (N)

Groundwater Elev.: _____ ft
 First Encounter 531.5 ft
 Upon Completion _____ ft
 After _____ Hrs.

TOPSOIL - 2 inches
 Dark brown CLAY, A-7

Brown CLAY, A-7

Brown CLAYEY SILT, A-4

Brown SILTY CLAY, A-8

Brown CLAY, trace sand, A-7

Boring terminated at 20.0 ft.

The Unconfined Compressive Strength (UCS) Failure Mode is Indicated by (B-Bulge, S-Shear, P-Penetrometer)
 AASHTO Classifications are based on visual classifications unless otherwise noted BBS, form 137 (Rev. 8-99)

DATE _____
 BY _____
 ORIGINAL SURVEYED SURVEY PLOTTED NOTE BOOK TEMPLATE AREAS CHECKED. NO.

DATE _____
 BY _____
 ORIGINAL SURVEYED SURVEY PLOTTED NOTE BOOK TEMPLATE AREAS CHECKED. NO.

ORIGINAL SURVEYED	BY	DATE
SURVEY PLOTTED		
NOTE BOOK TEMPLATE		
AREAS		
AREAS CHECKED		
NO.		

FINAL SURVEYED	BY	DATE
SURVEY PLOTTED		
NOTE BOOK TEMPLATE		
AREAS		
AREAS CHECKED		
NO.		

184+94.67 FRANK SCOTT PARKWAY EAST
SKEW AHEAD LT 23°

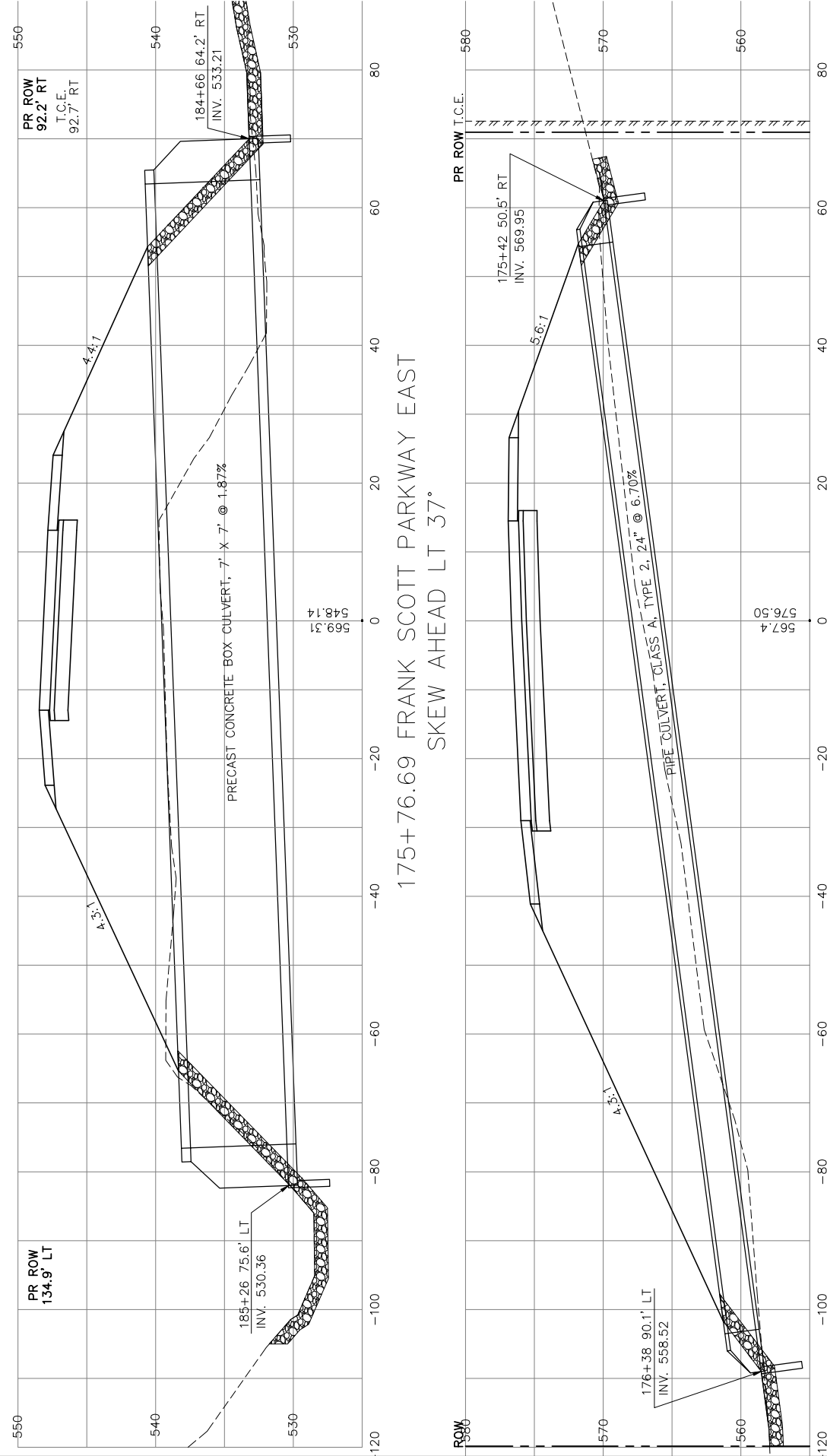

175+76.69 FRANK SCOTT PARKWAY EAST
SKEW AHEAD LT 37°

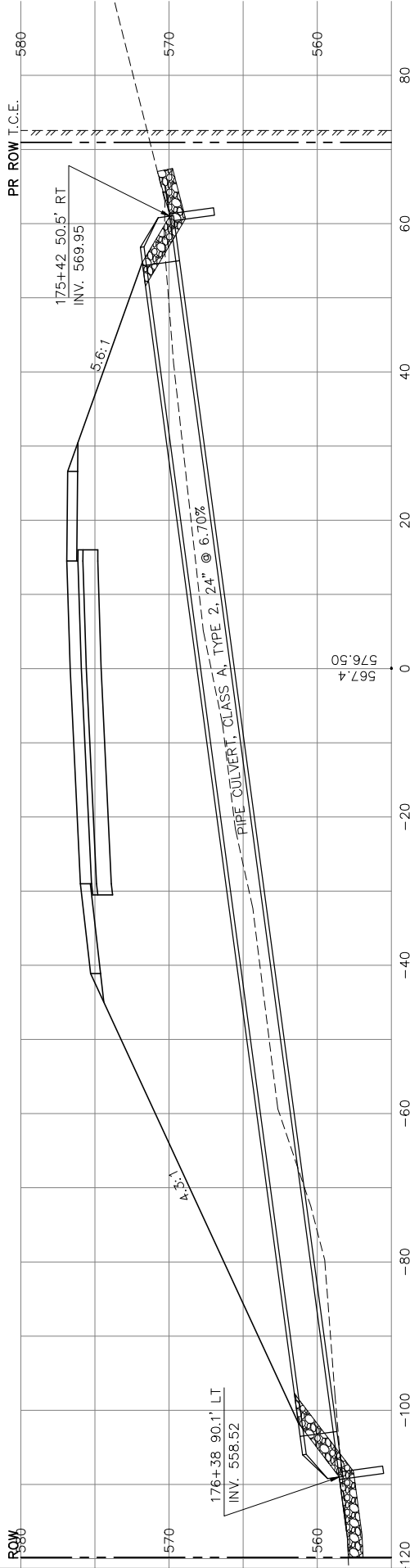

168+07.02 FRANK SCOTT PARKWAY EAST
SKEW AHEAD LT 21°

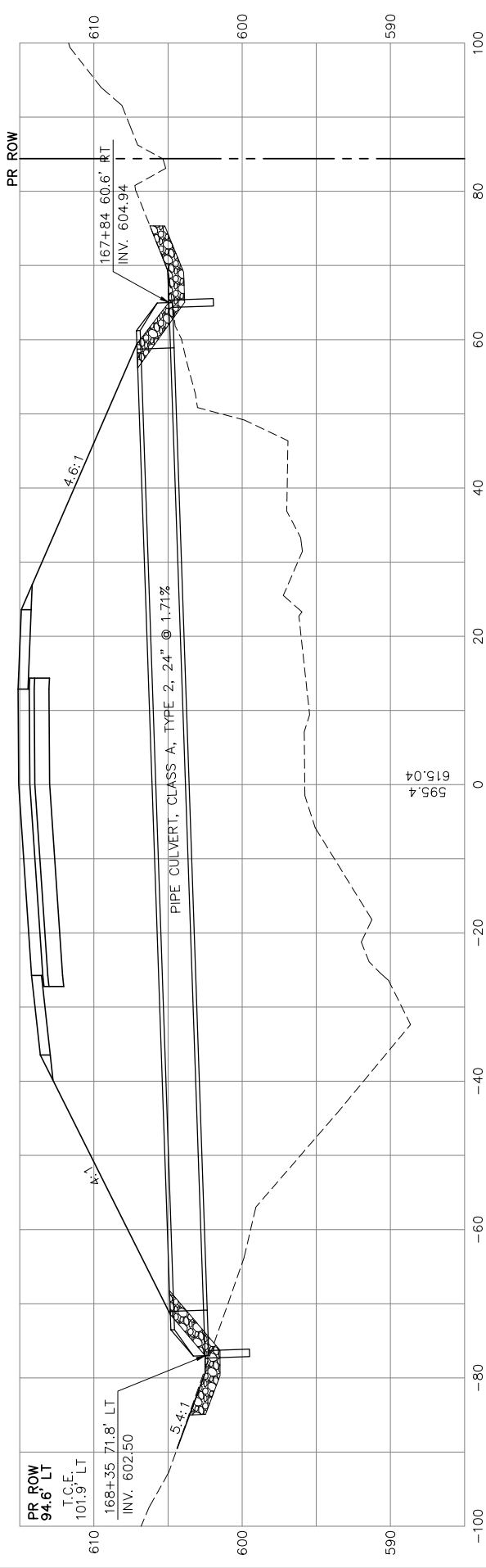

F.A.U. RTE.	SECTION	COUNTY	TOTAL SHEETS	SHEET NO.
9330	95-00301-03-PV	ST. CLAIR	166	94
STA.	TO STA.			
FED. ROAD DIST. NO.	ILLINOIS	FED. AID PROJECT		
CULVERT PROFILES				

CONTRACT NO.: 97372

ORIGINAL SURVEY PLOTTED	BY	DATE
NOTE BOOK TEMPLATE		
AREAS CHECKED		
NO.		

FINAL SURVEYED	BY	DATE
SURVEY PLOTTED		
NOTE BOOK TEMPLATE		
AREAS CHECKED		
NO.		

217+70.50 FRANK SCOTT PARKWAY EAST
SKEW AHEAD RT 30°

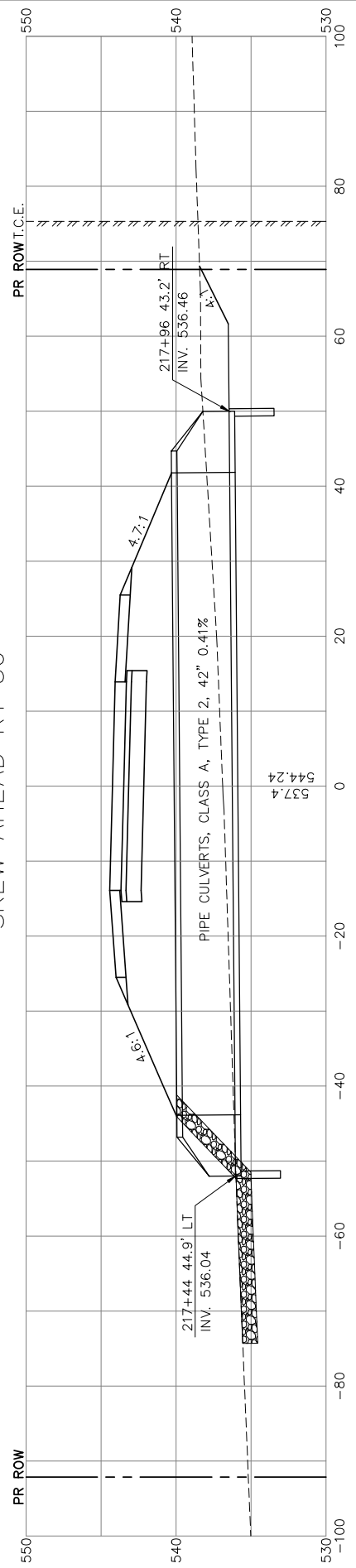

205+25.91 FRANK SCOTT PARKWAY EAST
SKEW AHEAD LT 28°

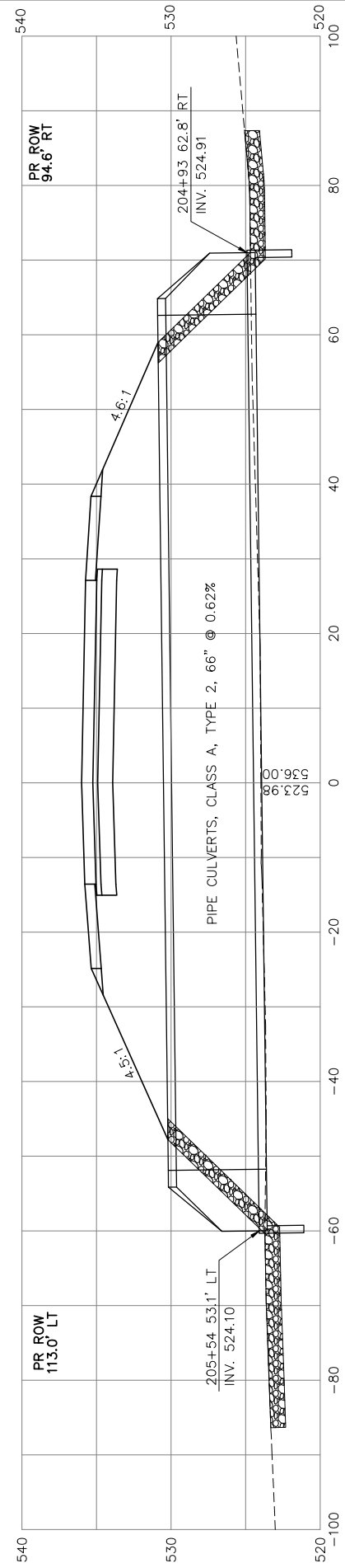

199+89.53 FRANK SCOTT PARKWAY EAST
SKEW AHEAD LT 22°

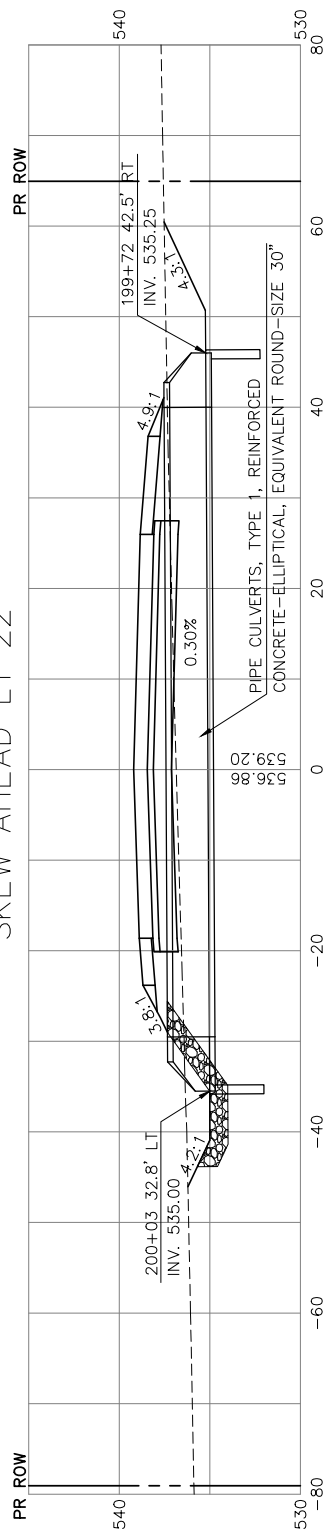

194+86.26 FRANK SCOTT PARKWAY EAST
SKEW AHEAD LT 38°

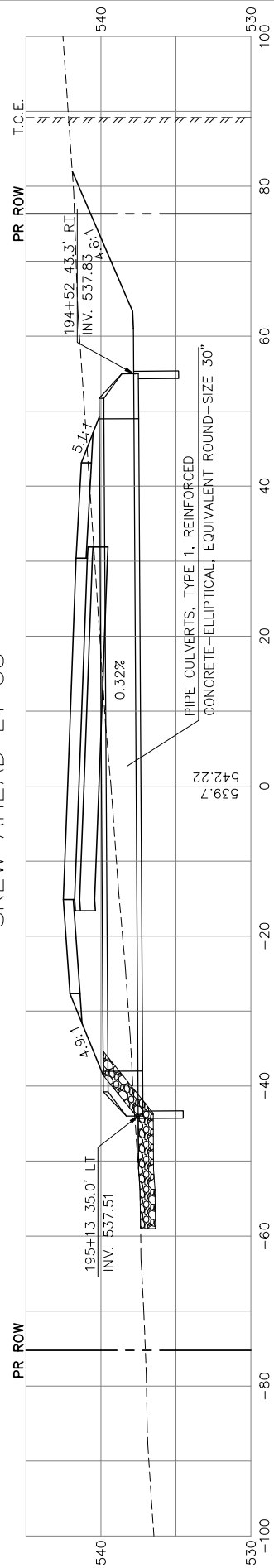

F.A.U. RTE.	SECTION	COUNTY	TOTAL SHEETS	SHEET NO.
9330	95-00301-03-PV	ST. CLAIR	166	95
STA.	TO STA.			
FED. ROAD DIST. NO.	ILLINOIS	FED. AID PROJECT		
CULVERT PROFILES				

CONTRACT NO.: 97372

ORIGINAL SURVEYED	BY	DATE
SURVEY PLOTTED		
NOTE BOOK TEMPLATE		
AREAS CHECKED		
NO.		

FINAL SURVEYED	BY	DATE
SURVEY PLOTTED		
NOTE BOOK TEMPLATE		
AREAS CHECKED		
NO.		

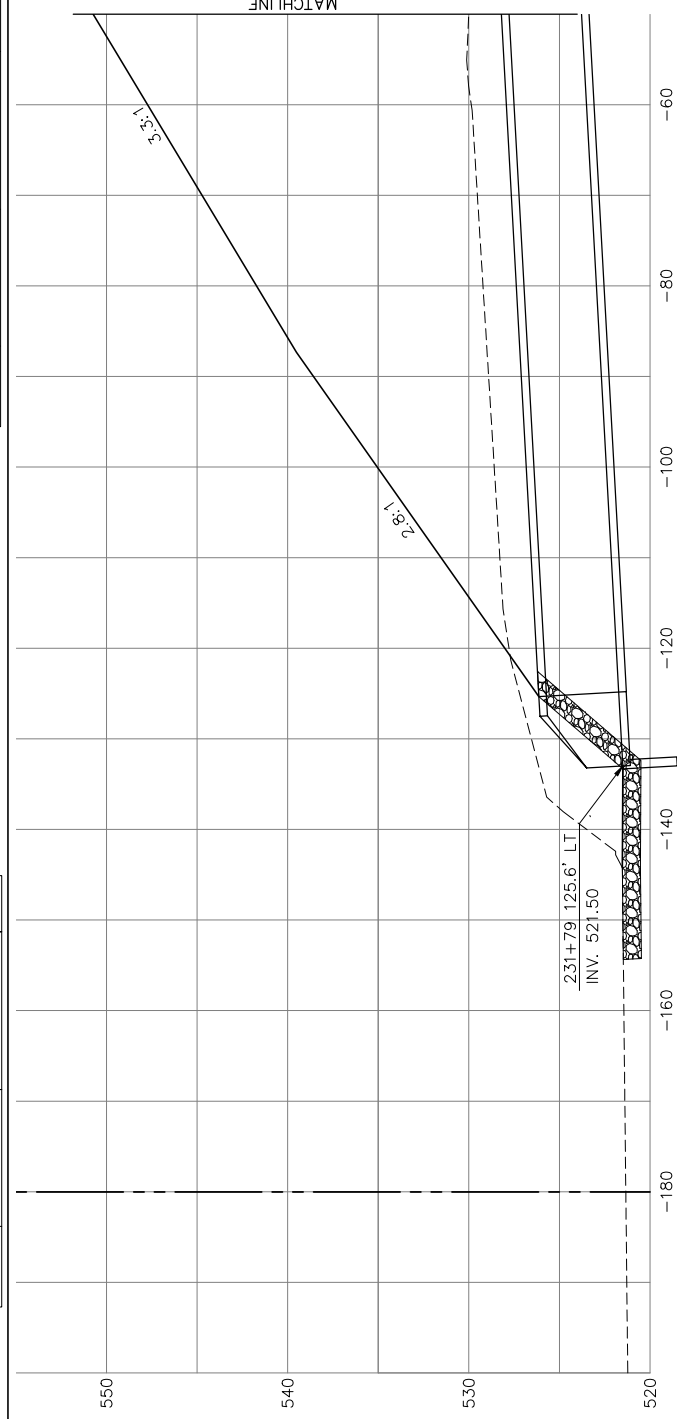

231+35.32 FRANK SCOTT PARKWAY EAST
SKEW AHEAD LT 19°

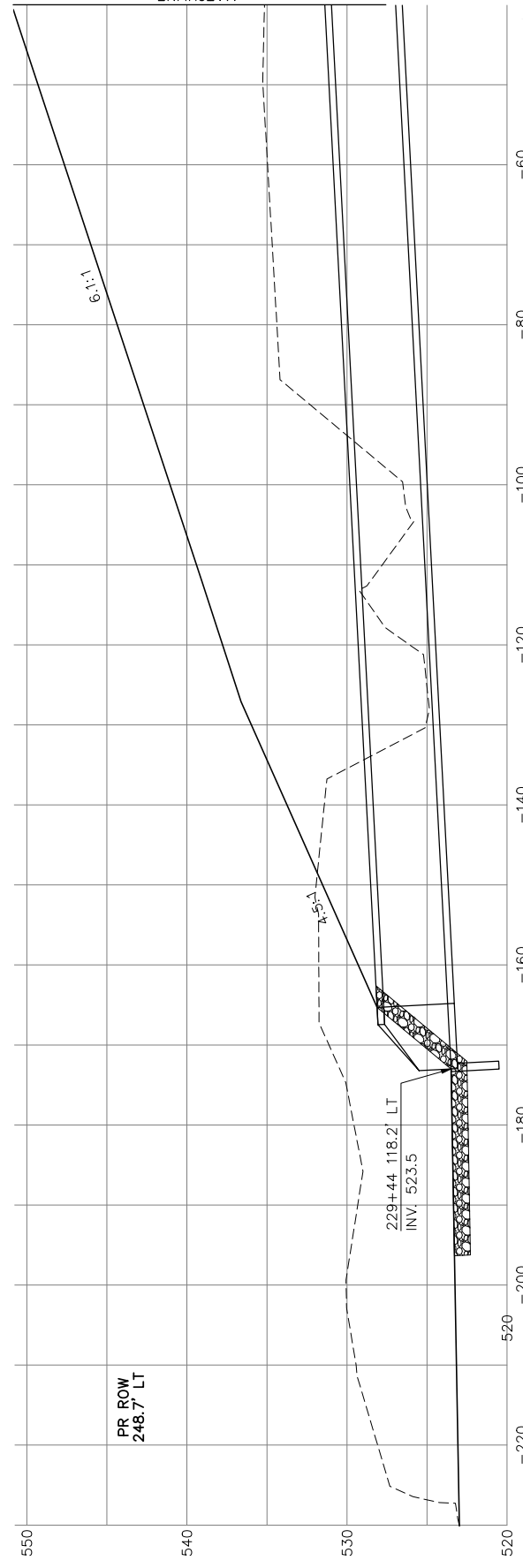
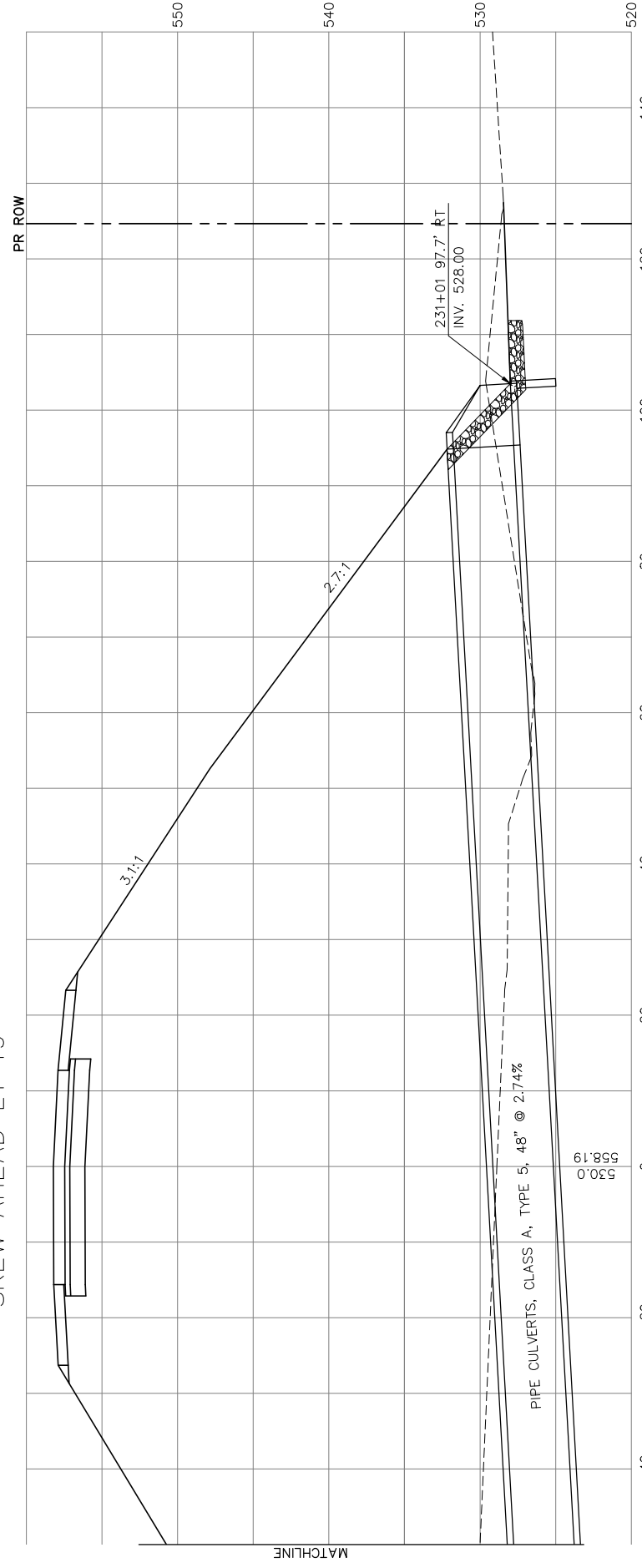

228+05.98 FRANK SCOTT PARKWAY EAST
SKEW AHEAD LT 49°29'9"

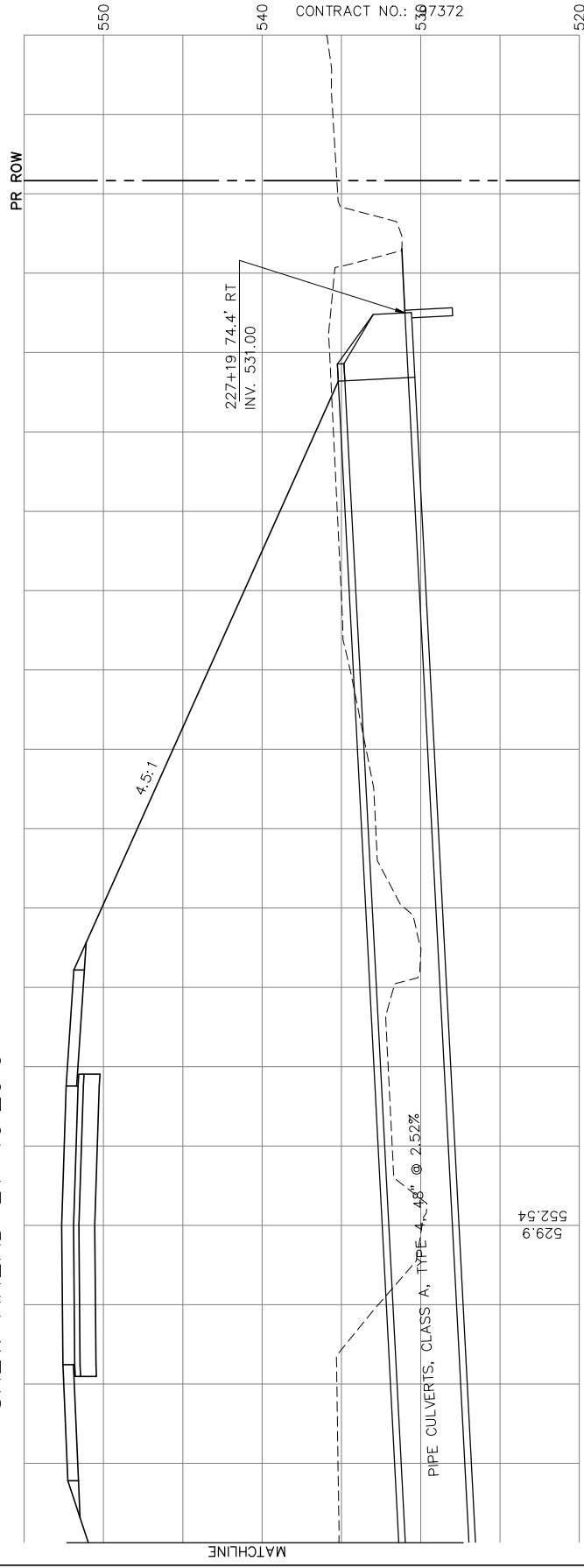

F.A.U. RTE.	SECTION	COUNTY	TOTAL SHEETS	SHEET NO.
9330	95-00301-03-PV	ST. CLAIR	166	96
STA.	TO STA.			
FED. ROAD DIST. NO.	ILLINOIS	FED. AID PROJECT		
CULVERT PROFILES				
CONTRACT NO.: 5307372				

ORIGINAL SURVEYED	BY	DATE
SURVEY PLOTTED		
NOTE BOOK TEMPLATE		
AREAS		
AREAS CHECKED		
NO.		

FINAL SURVEYED	BY	DATE
SURVEY PLOTTED		
NOTE BOOK TEMPLATE		
AREAS		
AREAS CHECKED		
NO.		

48+06.57 MAPLE STREET
SKEW AHEAD RT 48°

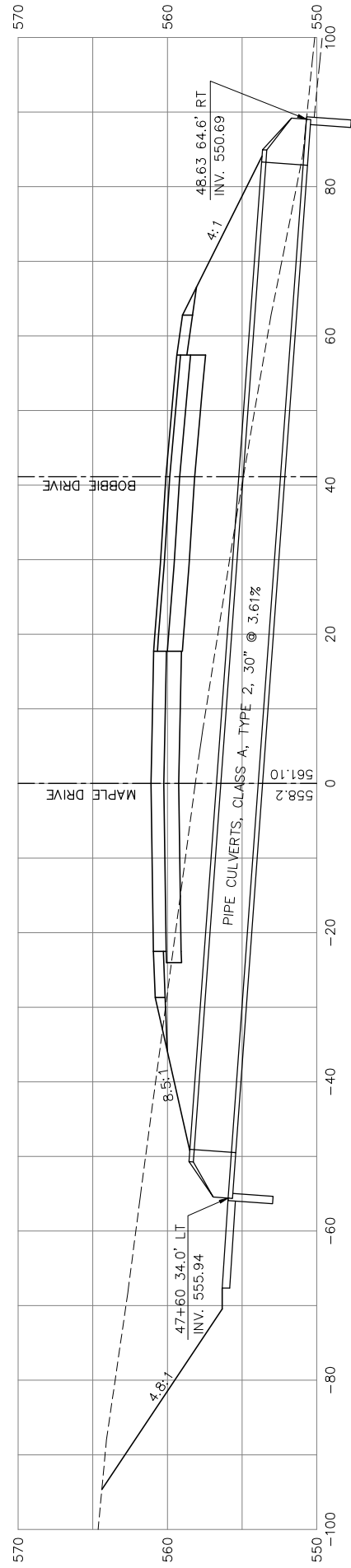

F.A.U. RTE.	SECTION	COUNTY	TOTAL SHEETS	SHEET NO.
9330	95-00301-03-PV	ST. CLAIR	166	97
STA.		TO STA.		
FED. ROAD DIST. NO.		ILLINOIS	FED. AID PROJECT	
CULVERT PROFILES				

CONTRACT NO.: 97372

ORIGINAL SURVEYED	BY	DATE
SURVEY PLOTTED		
NOTE BOOK TEMPLATE		
AREAS CHECKED		
NO.		

FINAL SURVEYED	BY	DATE
SURVEY PLOTTED		
NOTE BOOK TEMPLATE		
AREAS CHECKED		
NO.		

F.A.U. RTE.	SECTION	COUNTY	TOTAL SHEETS	SHEET NO.
9330	95-00301-03-PV	ST. CLAIR	166	98
STA.	159+50	TO STA.	163+00	
FED. ROAD DIST. NO.	ILLINOIS	FED. AID PROJECT		
CROSS SECTIONS FOR FRANK SCOTT PARKWAY EAST				

CONTRACT NO.: 97372

163+00

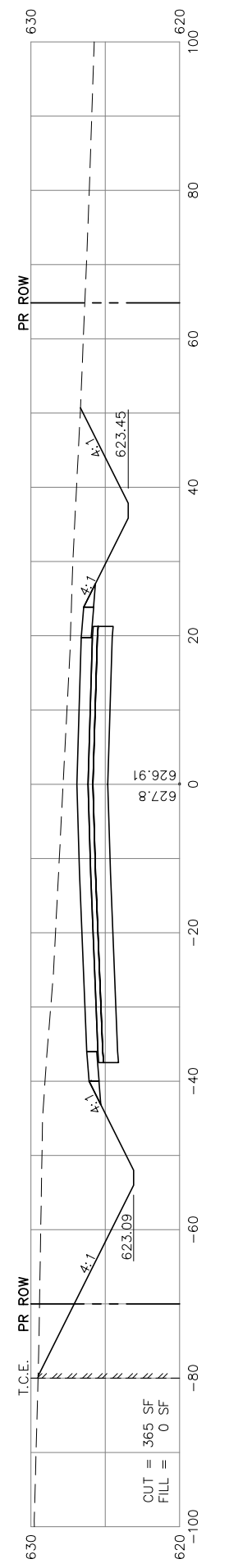

162+50

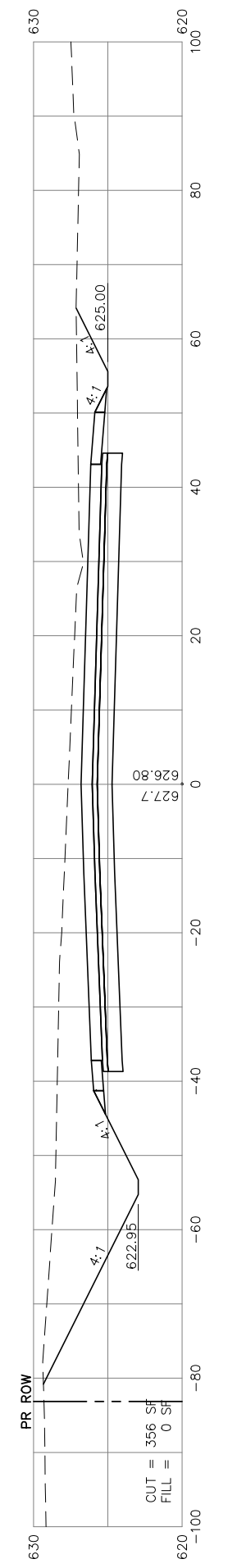

161+94.28
CROSS STREET

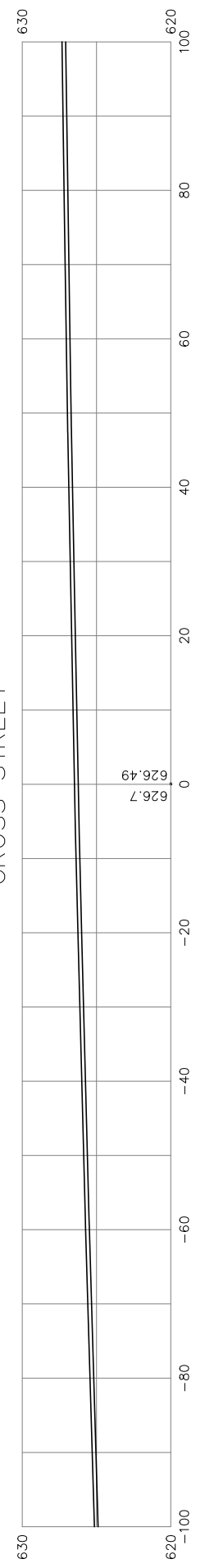

161+50

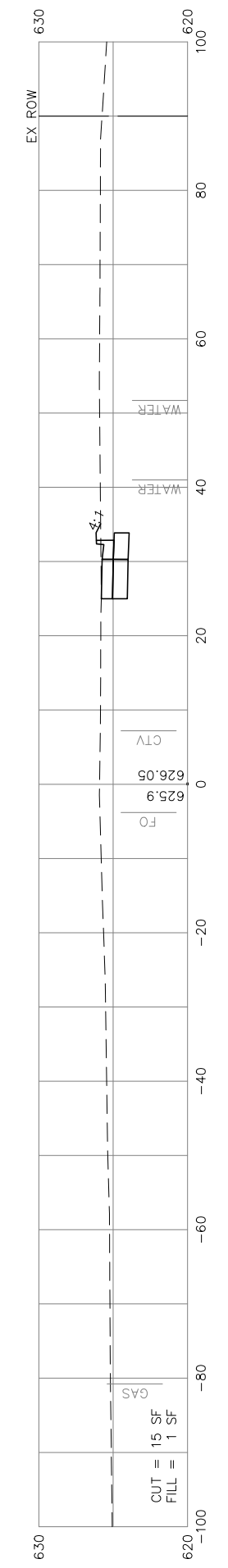

161+00

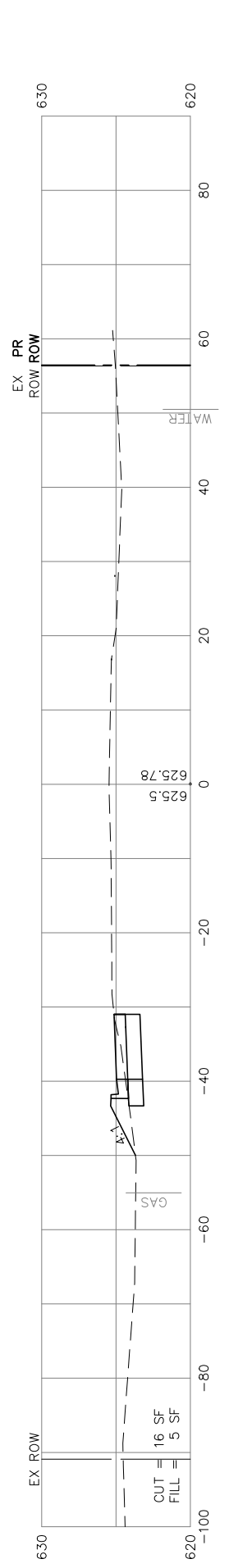

160+50

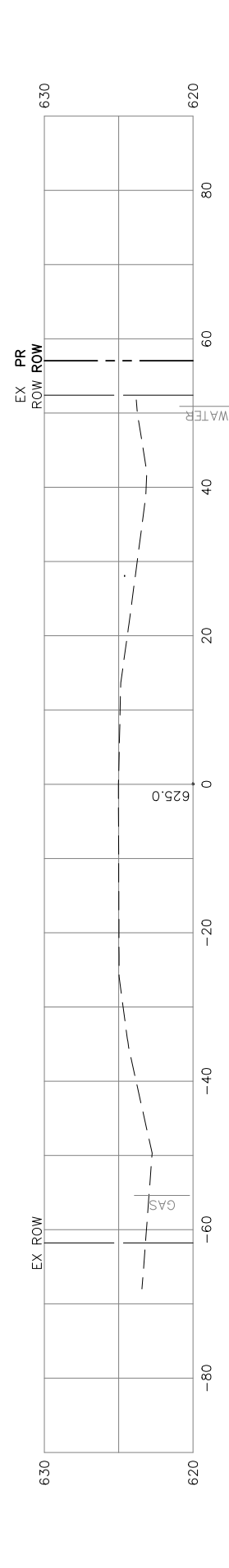

160+00

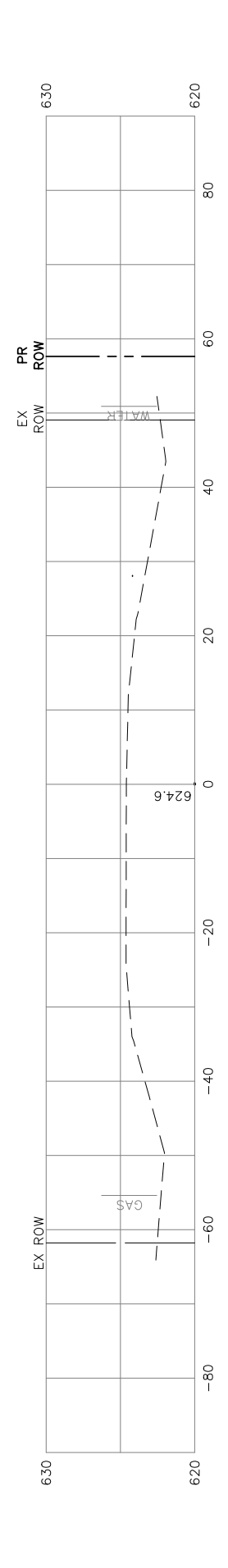

159+50

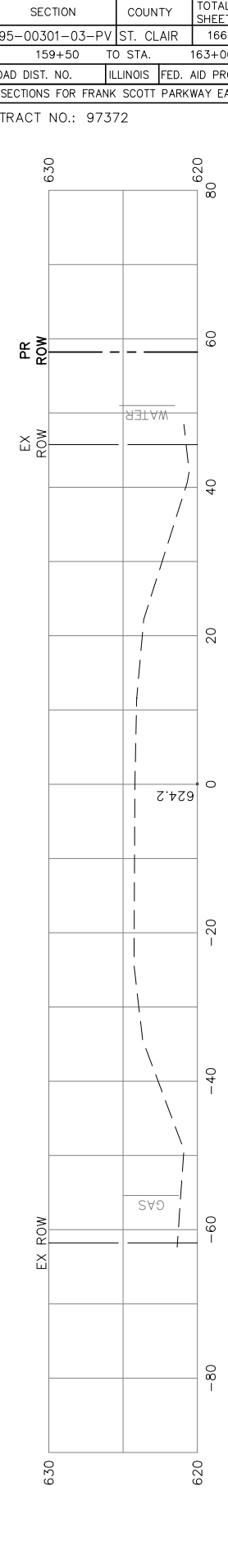

ORIGINAL SURVEYED	BY	DATE
SURVEY PLOTTED		
NOTE BOOK TEMPLATE		
AREAS CHECKED		
NO.		

FINAL SURVEYED	BY	DATE
SURVEY PLOTTED		
NOTE BOOK TEMPLATE		
AREAS CHECKED		
NO.		

166+50

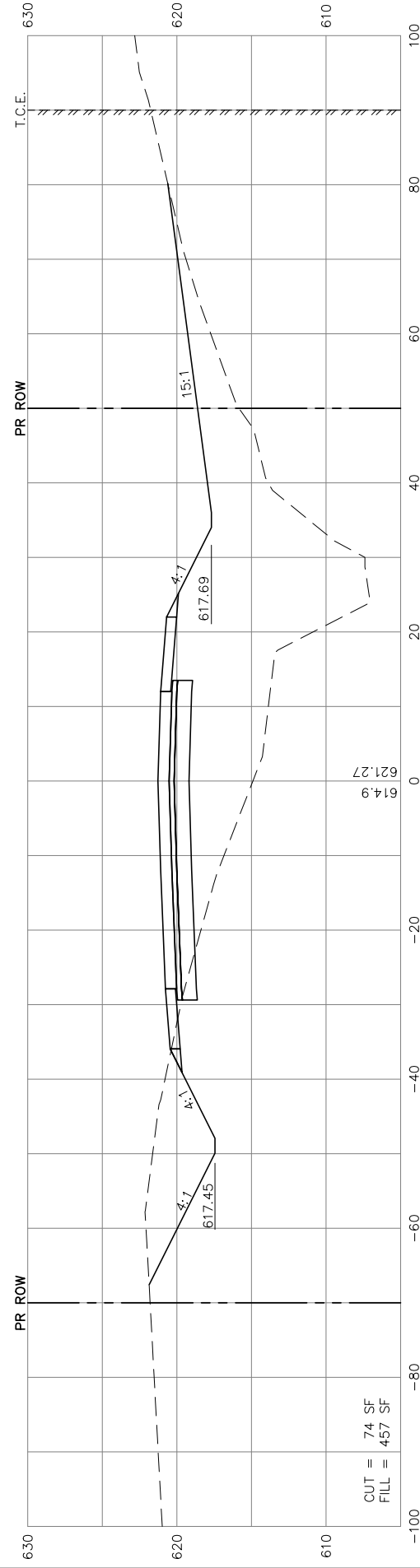

166+00

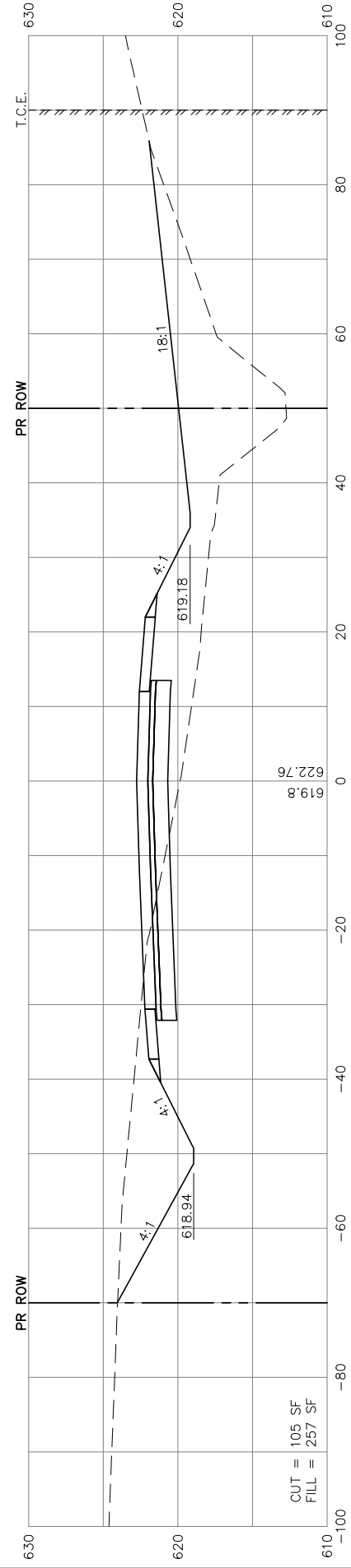

165+50

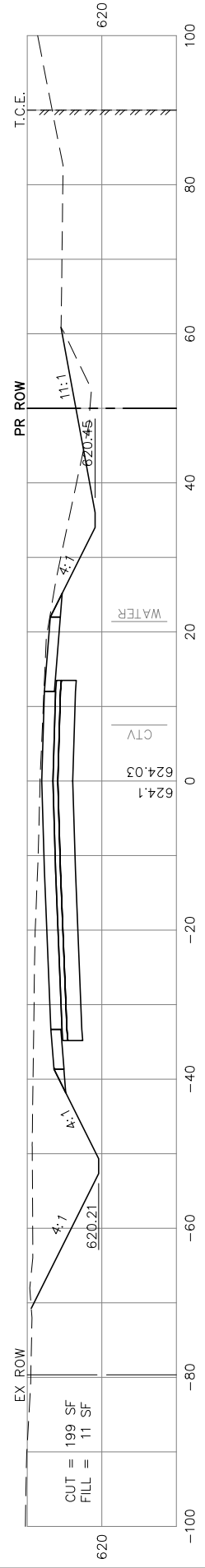

165+00

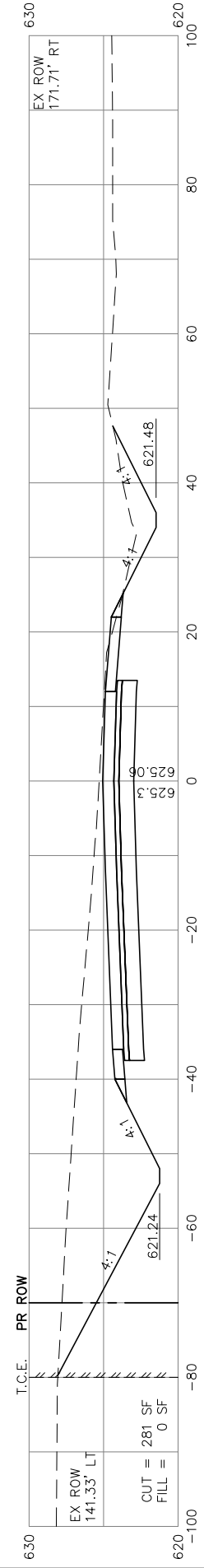

164+50

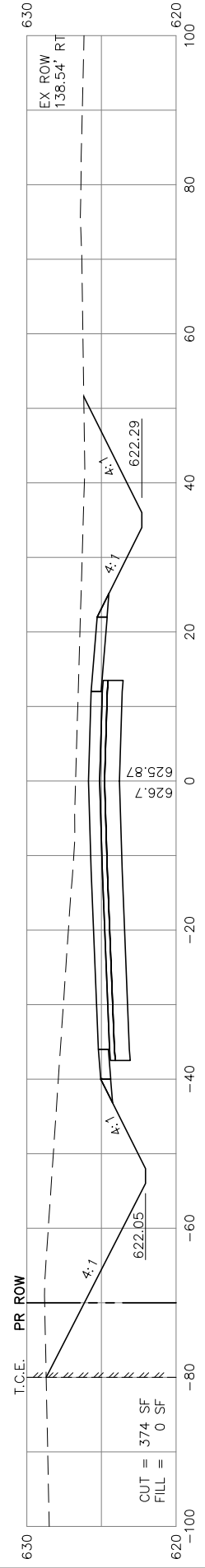

164+00

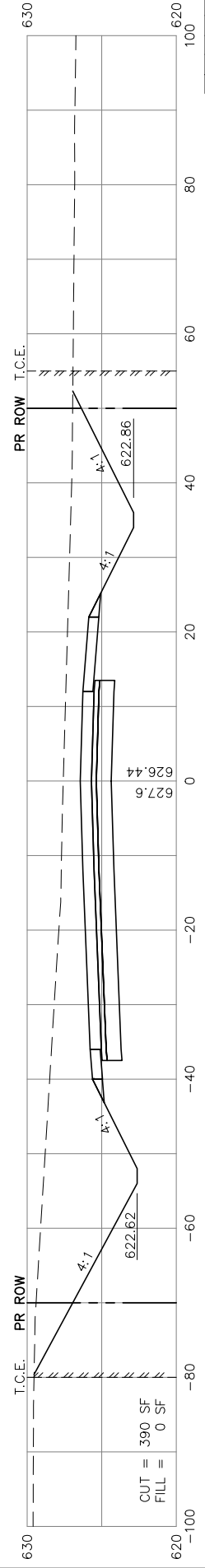

163+50

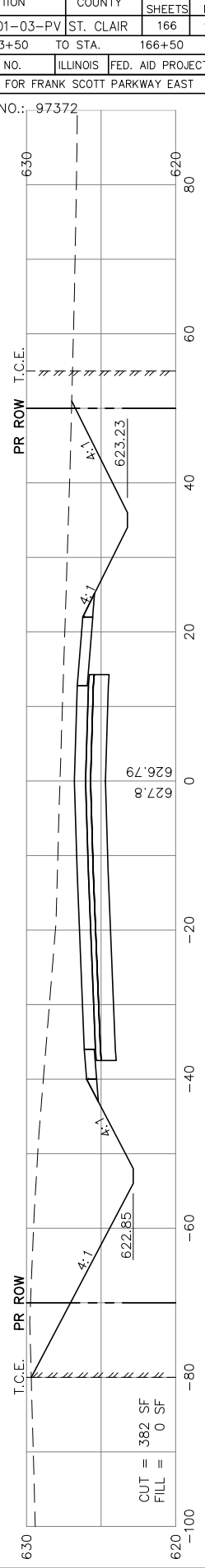

F.A.U. RTE.	SECTION	COUNTY	TOTAL SHEETS	SHEET NO.
9330	95-00301-03-PV	ST. CLAIR	166	99
STA. 163+50 TO STA. 166+50				
FED. ROAD DIST. NO.		ILLINOIS	FED. AID PROJECT	
CROSS SECTIONS FOR FRANK SCOTT PARKWAY EAST				

CONTRACT NO.: 97372

ORIGINAL SURVEYED	BY	DATE
SURVEY PLOTTED		
NOTE BOOK TEMPLATE		
AREAS CHECKED		
NO.		

FINAL SURVEYED	BY	DATE
SURVEY PLOTTED		
NOTE BOOK TEMPLATE		
AREAS CHECKED		
NO.		

168+50

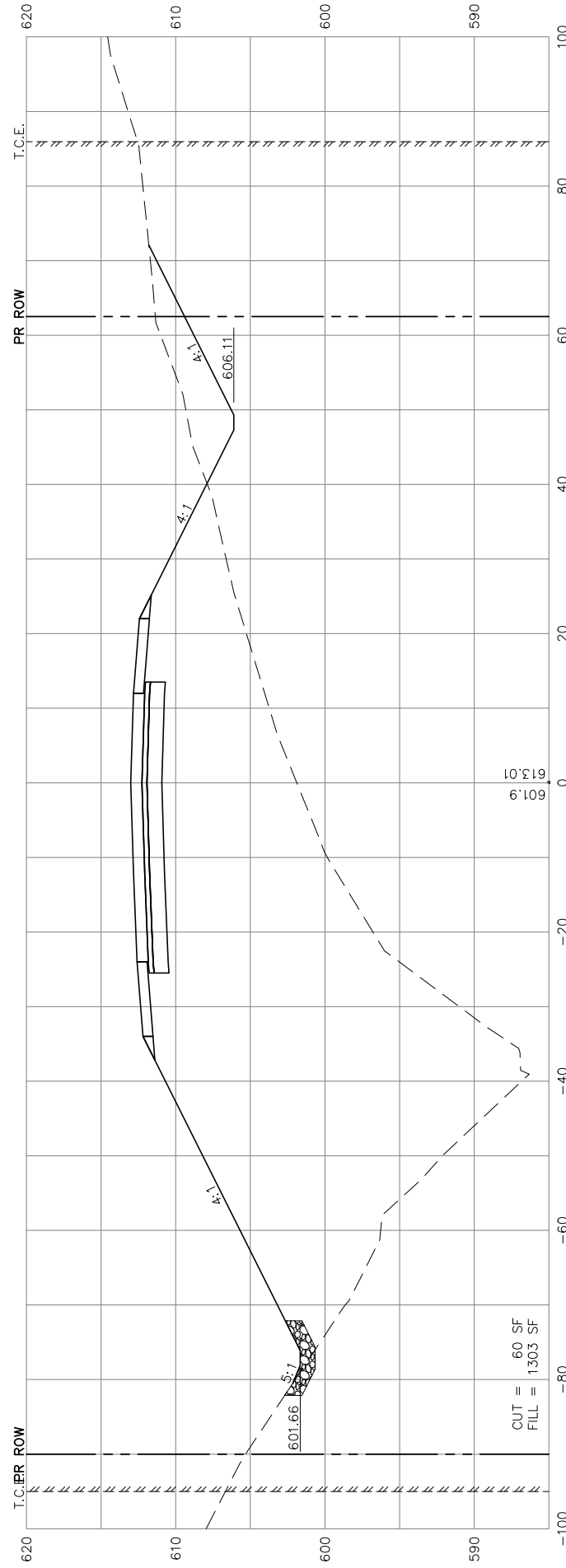

CUT = 60 SF
FILL = 1303 SF

168+00

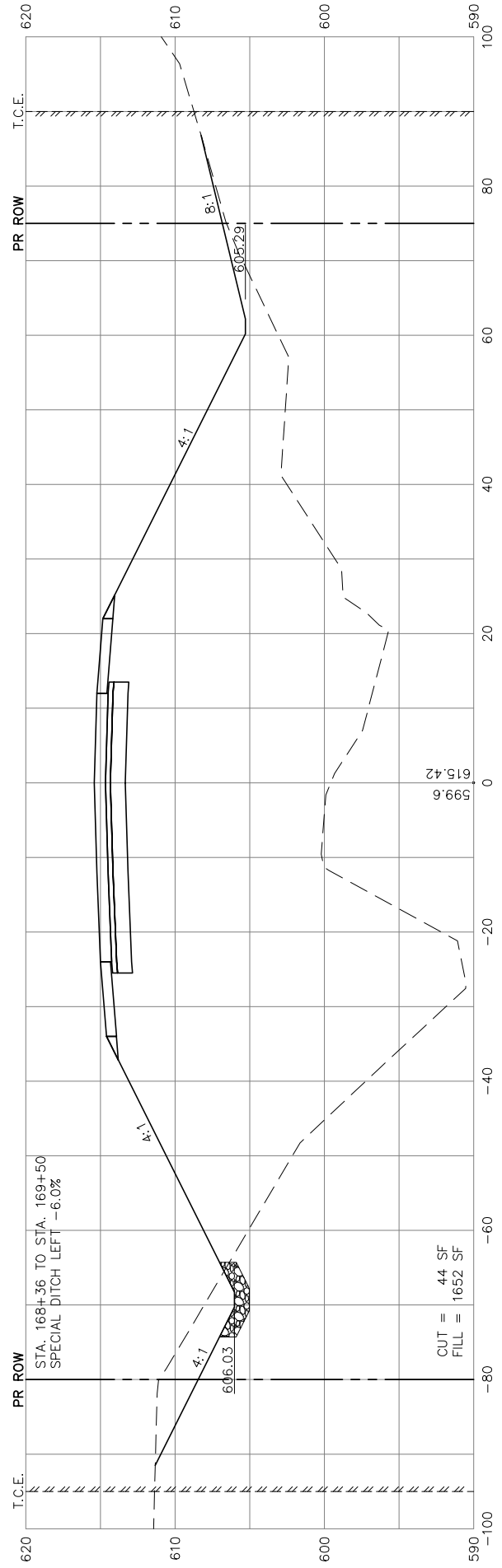

CUT = 44 SF
FILL = 1652 SF

167+50

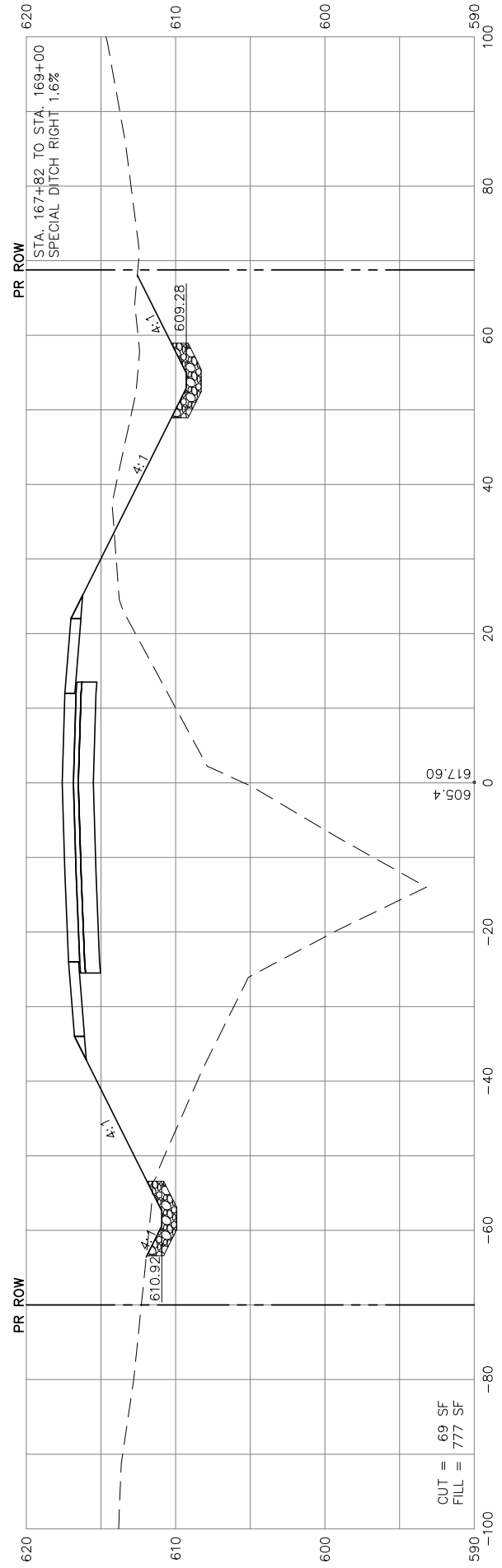

CUT = 69 SF
FILL = 777 SF

167+00

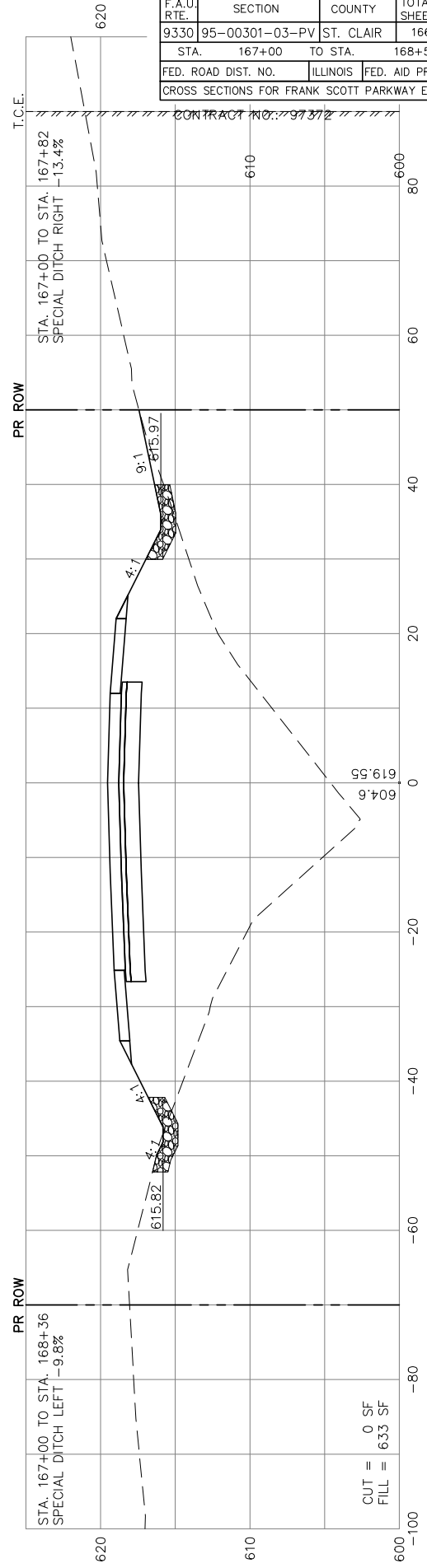

CUT = 0 SF
FILL = 633 SF

F.A.U. RTE.	SECTION	COUNTY	TOTAL SHEETS	SHEET NO.
9330	95-00301-03-PV	ST. CLAIR	166	100
STA. 167+00	TO STA. 168+50			
FED. ROAD DIST. NO.	ILLINOIS	FED. AID PROJECT		
CROSS SECTIONS FOR FRANK SCOTT PARKWAY EAST				

CONTRACT NO.: 97872