

FABRIC BEARING PAD
(Interior)

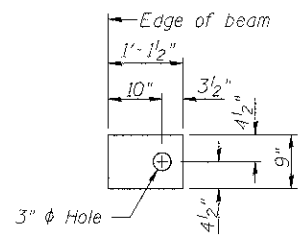

FABRIC BEARING PAD
(Exterior)

FIXED

Notes:

- All bearing pads shall be 1" thick.
- Omit holes when using expansion bearings.
- Expansion bearing pad shall be bonded to the substructure.

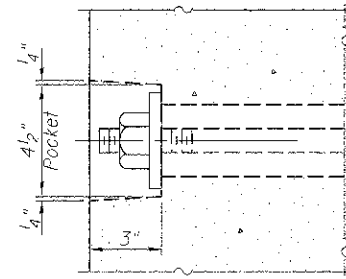

SECTION A-A

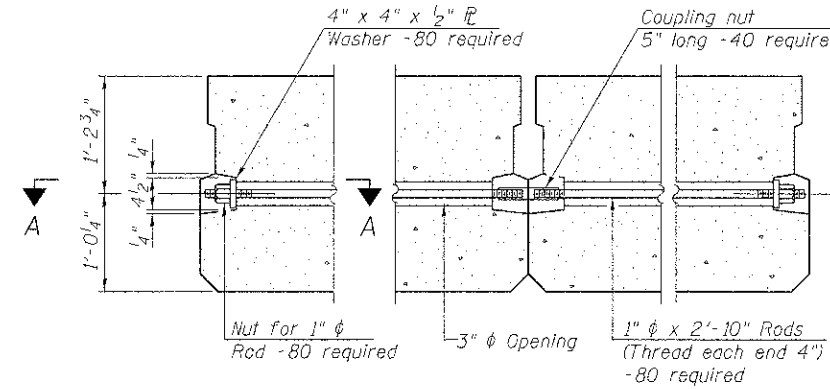

TYPICAL TRANSVERSE TIE ASSEMBLY

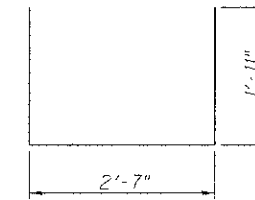

BAR S(E)

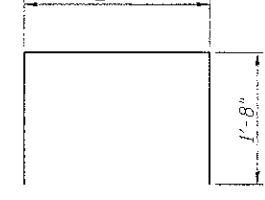

BAR S1(E)

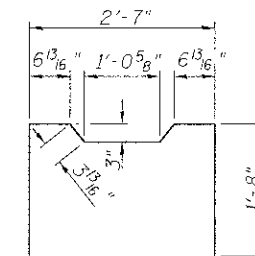

BAR S2(E)

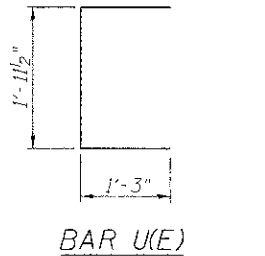

BAR U(E)

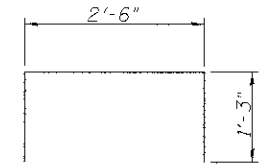

BAR U1(E)

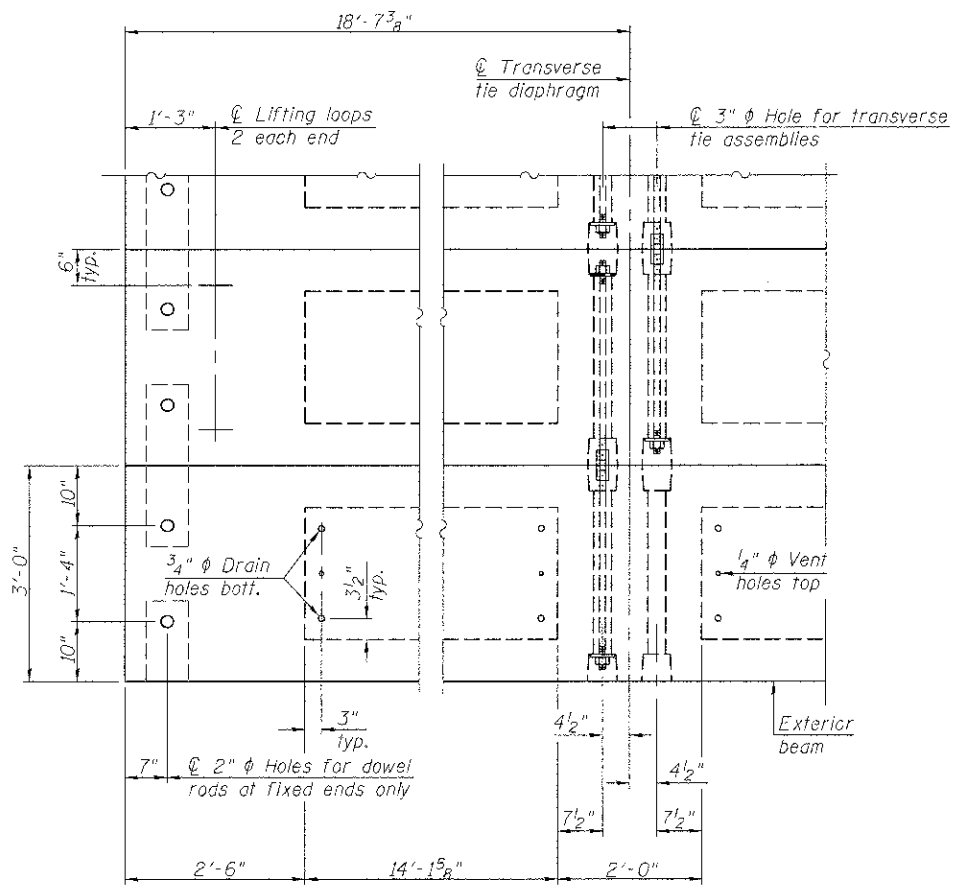

PLAN VIEW

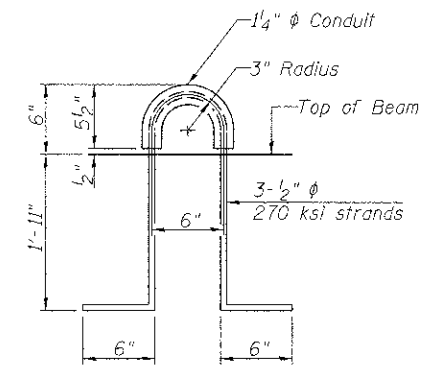

LIFTING LOOP DETAIL

NOTES

- Prestressing steel shall be uncoated high strength, low relaxation 7-wire strand, Grade 270. The nominal diameter shall be 1/2" and the nominal cross-sectional area shall be 0.153 sq. in.
- The 1" rods in the transverse tie assembly shall be tightened to a snug fit and the threads set. Pockets on exterior faces of bridge shall be filled with grout after transverse tie assembly is in place.
- Reinforcement bars shall conform to ASTM A 706, Grade 60. (See Special Provisions).
- Two 1/8" fabric adjusting shims of the dimensions of the exterior bearing pad shall be provided for each bearing pad location.
- A minimum 2 1/2" diameter lifting pin shall be used to engage the lifting loops during handling.
- Corrosion Inhibitor, per Article 1020.05(b)(12) and 1021.05 of the Standard Specifications, shall be used in the concrete for precast prestressed concrete deck beams.
- Compressive strength of prestressed concrete, f'c, shall be 6000 psi.
- Compressive strength of prestressed concrete at release, f'ci, shall be 5000 psi.

BILL OF MATERIAL

Precast Prestressed Conc. Deck Bms. (27" depth)	Sq. Ft.	3,981
---	---------	-------

Note: Connect beams in pairs with the transverse tie configuration shown.

PD-2736-0D 7-1-10

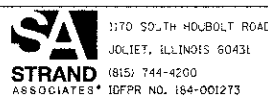

USER NAME = bstonf	DESIGNED RRD	REVISED -
PLOT SCALE =	CHECKED AJS	REVISED -
PLOT DATE = 8/23/2012	DRAWN B/JF	REVISED -
	CHECKED RRD	REVISED -

MCHENRY COUNTY DIVISION OF TRANSPORTATION
HILL ROAD BRIDGE OVER
NORTH BRANCH NIPPERSINK CREEK

27" x 36" PPC DECK BEAM DETAILS
STRUCTURE NO. 056-3192

SHEET NO. 11 OF 27 SHEETS

TR	SECTION	COUNTY	TOTAL SHEETS	SHEET NO.
21	08-00356-00-BR	MCHENRY	77	41
			CONTRACT NO. 63666	

ILLINOIS FED. AID PROJECT

FILE NAME = s:\proj\6820-6899\6842\087\vincros\cadd\sheet\structure\VR5-3192-57666-011-BE.dwg