

④ Collar I.D. shall be manufactured to correspond to O.D. of actual galvanized post and stainless steel sleeve plus 1/8" (± 1/16"). Maximum gap between post and collar at any location equals 1/8" before tightening bolts.

SECTION B-B
Bolts, washers (including contoured washers), and locknuts shall be stainless steel.

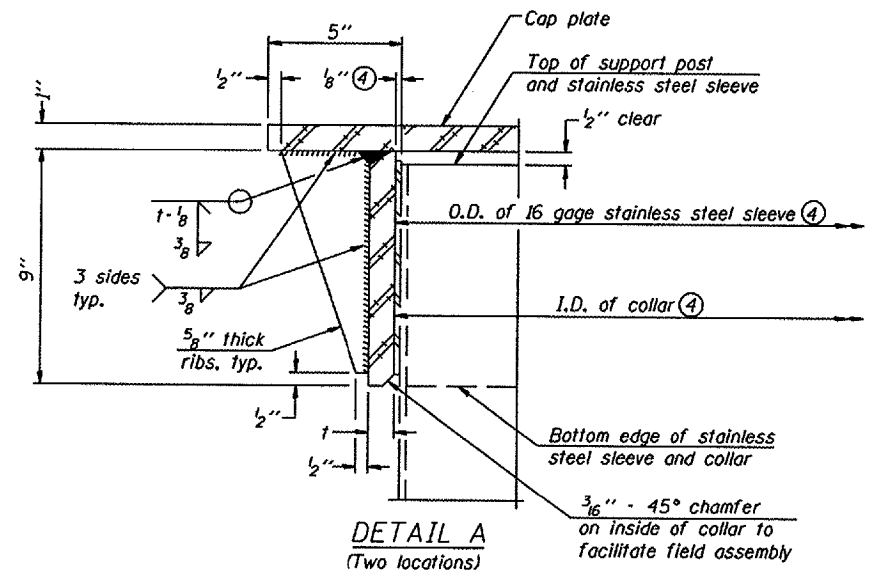

DETAIL A
(Two locations)
3/16" - 45° chamfer on inside of collar to facilitate field assembly

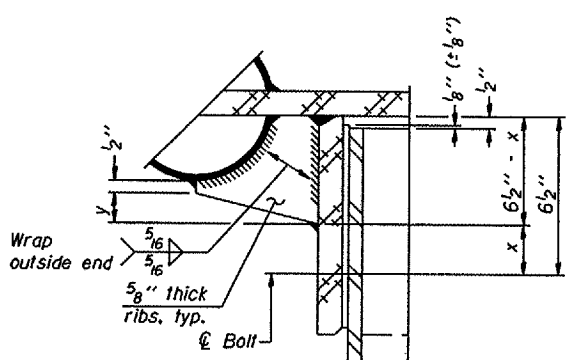

DETAIL B
Two locations
(For details not shown, see Detail C)

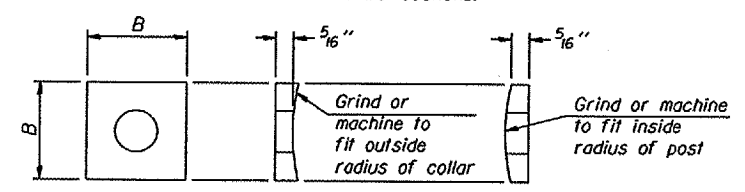

CONTOURED WASHERS

Bolt Size	Contoured Washers	
	Hole Dia.	B
7/8"	1"	2 1/2"
1"	1 1/8"	3"
1 1/4"	1 3/8"	3 1/4"

DETAIL OF STAINLESS STEEL SLEEVE

Weld to post after galvanizing. (Prepare post surface to insure tight, uniform fit and allow welding.) Welds to be 1/2" long at 6" cts. along top edge and at 1/4" opening.

NUMBER	REVISION	DATE

DESIGNED -	20
CHECKED -	EXAMINED
DRAWN -	PASSED
CHECKED -	ENGINEER OF BRIDGE DESIGN
	ENGINEER OF BRIDGES AND STRUCTURES

OSC-A-3 6/01/2007

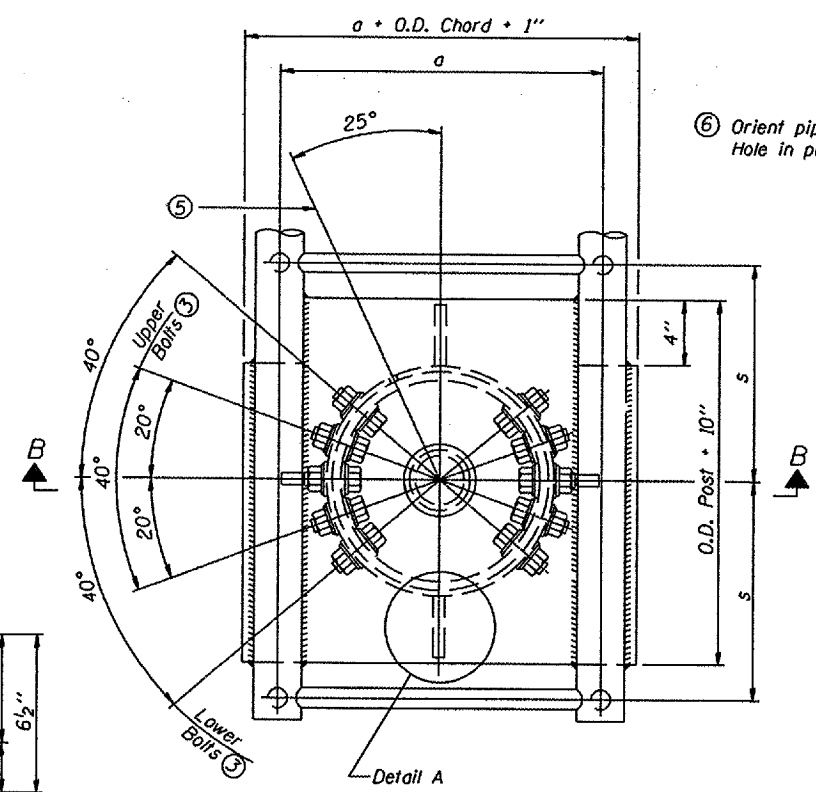

PLAN VIEW - TOP OF COLUMN

⑤ Optional full penetration weld in collar. (Two locations maximum....(180° apart)....X-ray or UT 100%)

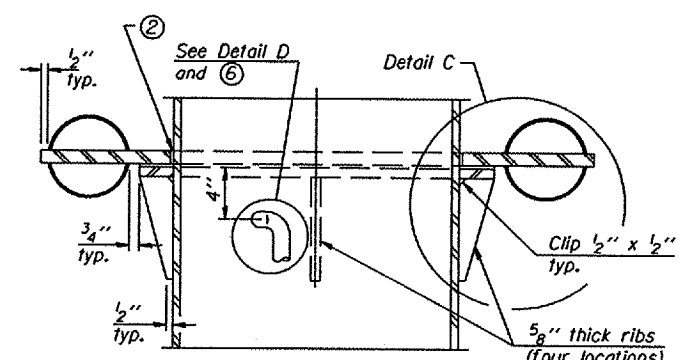

SECTION C-C

This Sheet For Information Only

Truss Type	Post Size	Upper & Lower Connection Bolt Diameter ③	Lower Juncture Bolt Spacing Dimension "c" ③	Opening in Cap Plate "HH"	Collar Thickness (t)	Side Ribs	
						x	y
I-C-A	16" φ (83#/1')	7/8"	3 1/4"	8"	5/8"	1 3/4"	2 1/4"
II-C-A	24" φ (125#/1')	1"	3 1/2"	12"	7/8"	2"	1 1/4"
III-C-A (35' max.)	24" φ (125#/1')	1 1/4"	3 1/2"	12"	7/8"	2"	1"
III-C-A (>35' to 40')	24" φ (171#/1')	1 1/4"	3 1/2"	12"	7/8"	2"	1"

③ Upper and lower connection bolts in collar and bolts at lower chord connection shall be high strength with matching locknuts. Connection bolts shall have 2 stainless steel flat washers each.

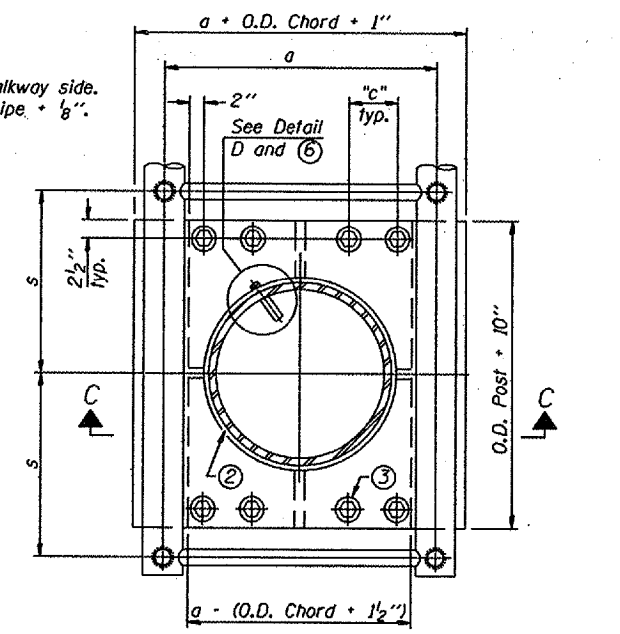

SECTION THRU POST ABOVE LOWER CHORDS

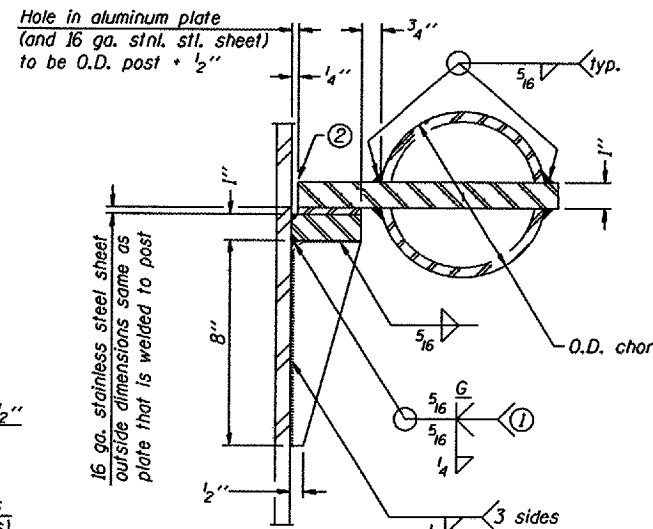

DETAIL C

① Grind top if required to fully seat aluminum plate and stainless steel sheet.
② After tightening lower connection bolts, fill gap with non-hardening, silicone caulk suitable for exterior exposure and acceptable to the Engineer. Cost is included in Overhead Sign Structure Cantilever.

**CANTILEVER SIGN STRUCTURES
JUNCTURE DETAILS
ALUMINUM TRUSS & STEEL POST**

District 1
Overhead Sign Structure
Repair and Replacement