

STATE OF ILLINOIS  
DEPARTMENT OF TRANSPORTATION

ROUTE NO.	SECTION	COUNTY	TOTAL SHEETS	SHEET NO.
FAP 370	01031-2	COOK	21	17
FED. ROAD DIST. NO. 7	ILLINOIS	STANDARD PROJECT		

SHEET NO. 9  
10 SHEETS

Contract # 62362

**NOTES**

Bar splicer assemblies shall be of an approved type and shall develop in tension at least 125 percent of the yield strength of the lapped reinforcement bars.  
Splicer rods shall be of minimum 60 ksi yield strength, threaded or coiled full length.  
All reinforcement bars shall be lapped and tied to the splicer rods or dowel bars.  
Bar splicer assemblies shall be epoxy coated according to the requirements for reinforcement bars.  
Other systems of similar design may be submitted to the Engineer for approval. Approval shall be based on certified test results from an approved testing laboratory that the proposed bar splicer assembly satisfies the following requirements:

- ① Minimum Capacity (Tension in kips) =  $1.25 \times f_y \times A_l$
  - ② Minimum \*Pull-out Strength (Tension in kips) =  $0.66 \times f_y \times A_l$
- Where  $f_y$  = Yield strength of lapped reinforcement bars in ksi.  
 $A_l$  = Tensile stress area of lapped reinforcement bars.  
\* = 28 day concrete

Bar Size to be Spliced	Splicer Rod or Dowel Bar Length	Strength Requirements	
		Min. Capacity kips - tension	Min. Pull-Out Strength kips - tension
#4	1'-8"	14.7	7.9
#5	2'-0"	23.0	12.3
#6	2'-7"	33.1	17.4
#7	3'-5"	45.1	23.8
#8	4'-6"	58.9	31.3
#9	5'-9"	75.0	39.6
#10	7'-3"	95.0	50.3
#11	9'-0"	117.4	61.8

The diameter of this part is equal or larger than the diameter of bar spliced.

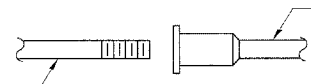

ROLLED THREAD DOWEL BAR



\*\* ONE PIECE

Wire Connector



WELDED SECTIONS

**BAR SPLICER ASSEMBLY ALTERNATIVES**

\*\* Heavy Hex Nuts conforming to ASTM A 563, Grade C, D or DH may be used.

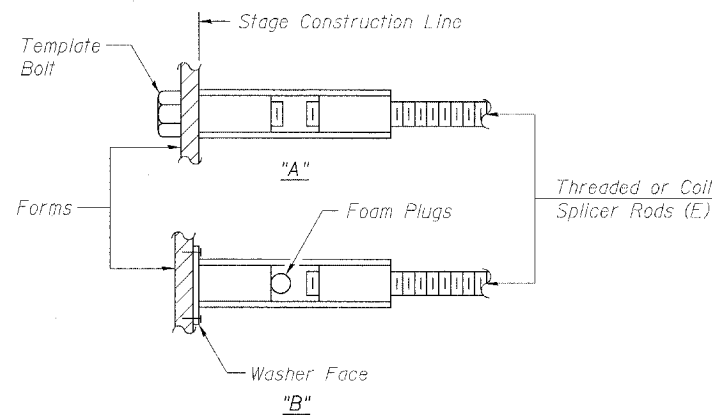

**INSTALLATION AND SETTING METHODS**

"A" : Set bar splicer assembly by means of a template bolt.  
"B" : Set bar splicer assembly by nailing to wood forms or cementing to steel forms.  
(E) : Indicates epoxy coating.

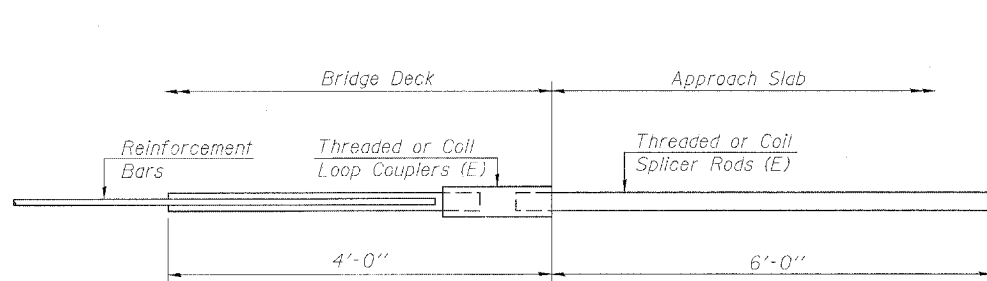

**FOR INTEGRAL OR SEMI-INTEGRAL ABUTMENTS**

Bar Splicer for #5 bar
Min. Capacity = 23.0 kips - tension
Min. Pull-out Strength = 12.3 kips - tension
No. Required = 0

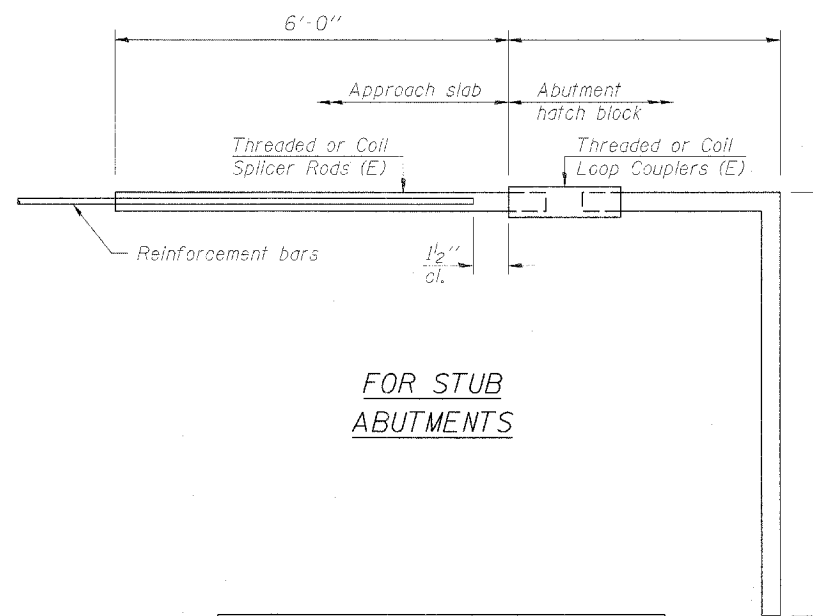

**FOR STUB ABUTMENTS**

Bar Splicer for #5 bar
Min. Capacity = 23.0 kips - tension
Min. Pull-out Strength = 12.3 kips - tension
No. Required = 0

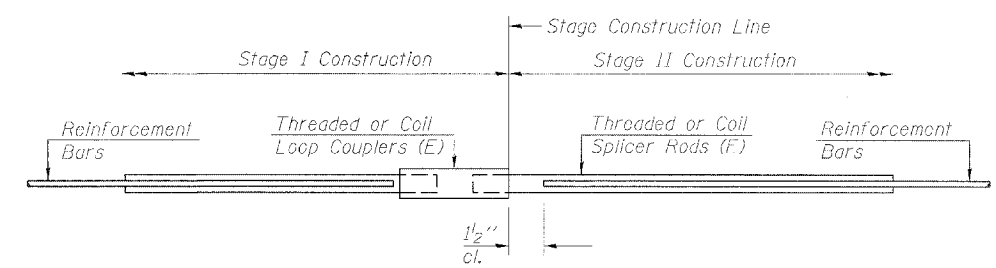

**STANDARD**

Bar Size	No. Assemblies Required	Location
#4	80	Stage Const. Joint
#4	152	Sidewalks
#5	274	PPC Deck Beams

**BAR SPLICER ASSEMBLY DETAILS**

GREGORY STREET  
OVER VERMONT STREET  
SECTION 01031-2  
COOK COUNTY  
STRUCTURE NO. 016-0776  
STATION 42+37.22

**GRAEF ANHALT SCHLOEMER**  
CONSULTING ENGINEERS AND LAND SURVEYORS  
8501 W. Higgins Road, Suite 280  
Chicago, Illinois 60631  
(773) 399-0112

DESIGNED -
CHECKED -
DRAWN -
CHECKED -

BSD-1

11-1-06