

- \* Transverse Strand Placement Guidelines**
1. Place strands symmetrically about centerline of beam.
  2. The minimum distance from center to center of strands in all directions shall be 2".
  3. The minimum clearance from strand to dowel hole shall be 1/2".
  4. The minimum clearance from strand to void shall be 1/2".

**TIE ROD SCHEDULE**

BEAM	LENGTH	QUANTITY
6	2'-11"	2
9	3'-11"	1
12	2'-11"	2
15	2'-11"	2
21	2'-11"	2
26	3'-11"	2

**DIMENSION TABLE**

BEAM	LOCATION	LENGTH
9	A	48"
	B	10"
	C	1'-2"
	D	1'-5 1/2"
	E	2'-4"
	E'	2'-11 1/2"
	F	15'-7 3/4"
26	F'	16'-5 3/8"
	G	1'-7 3/8"
	A	47"
	B	9 1/2"
	C	1'-1 1/2"
	D	1'-5 1/2"
	E	1'-6"
E'	2'-11 1/8"	
F	16'-5 3/4"	
F'	16'-6"	
G	9"	

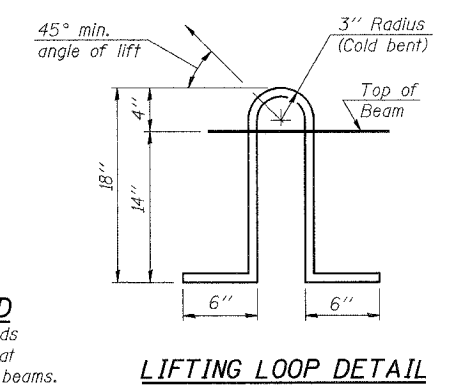
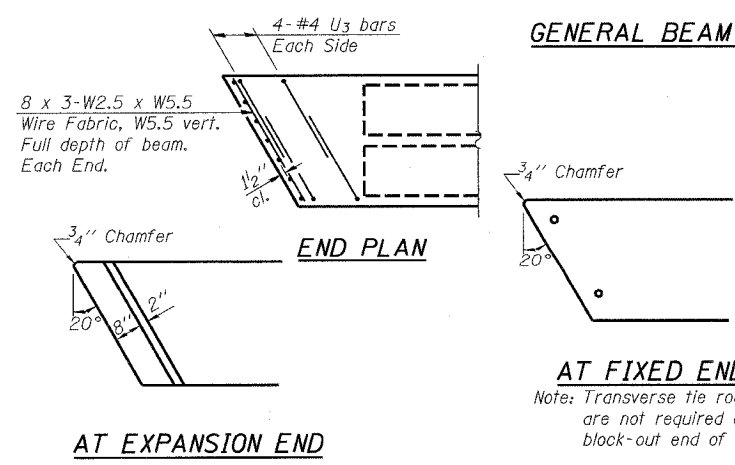
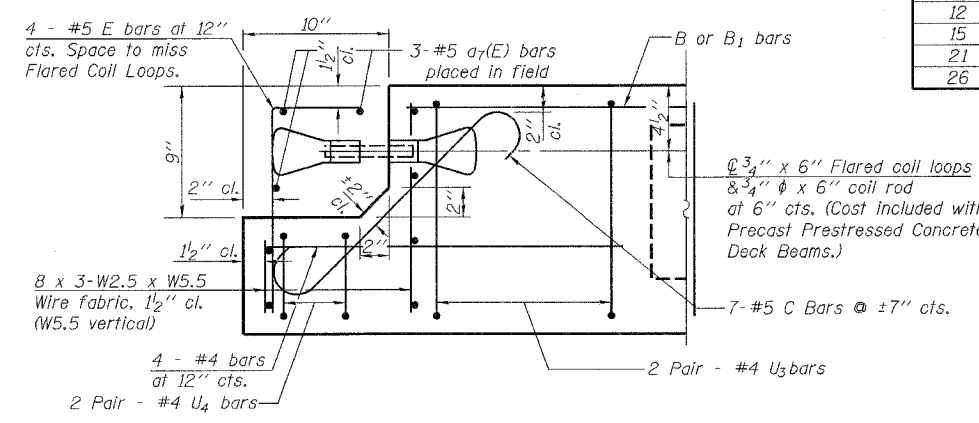
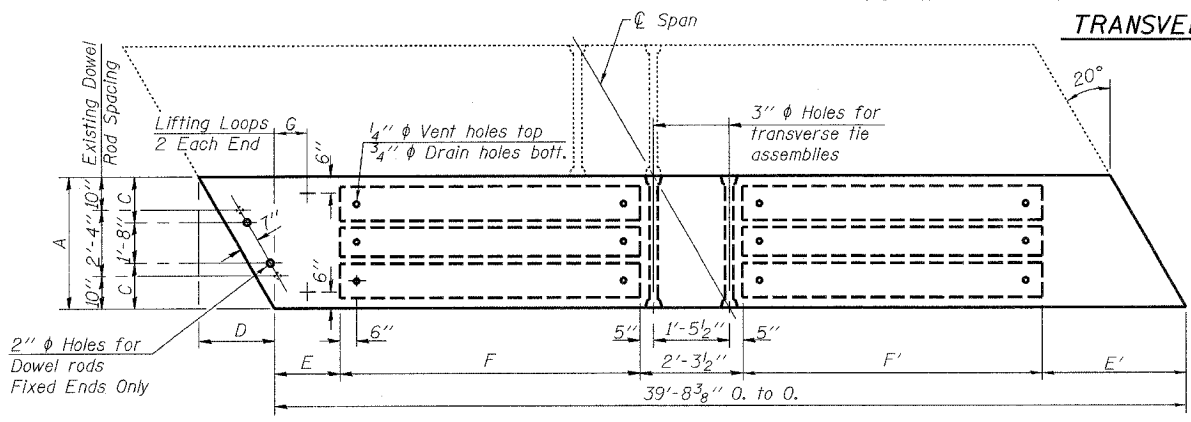

**NOTES**

Prestressing steel shall be uncoated high strength, low relaxation 7-wire strand, Grade 270. The nominal diameter shall be 1/2" and the nominal cross-sectional area shall be 0.153 sq. in. Lifting loops shall be 2 - 1/2" diameter 270 ksi strands, as shown. The 1" rods in the transverse tie assembly shall be tightened to a snug fit and the threads set. Pockets that receive transverse tie bar on outside shall be filled with grout after transverse tie assembly is in place.

Non prestressing steel shall conform to ASTM A 706 (IL MOD), Grade 60. The bearing seat surfaces shall be adjusted by shimming to assure firm and even bearing. Two 1/8" fabric adjusting shims of the dimensions of the Exterior Bearing Pad shall be provided for each bearing.

Keyway surfaces shall be cleaned to remove form oil or other bond breaking material prior to shipment of the beams. Cleaning shall be done by sandblasting the keyway areas between top of the beam and the bottom edge of the key.

Corrosion Inhibitor, per Article 1020.05(b)(12) and 1021.06 of the Standard Specifications, shall be used in the concrete for precast prestressed concrete deck beams. Required Release Strength, f'cl, shall be 4000 p.s.i.

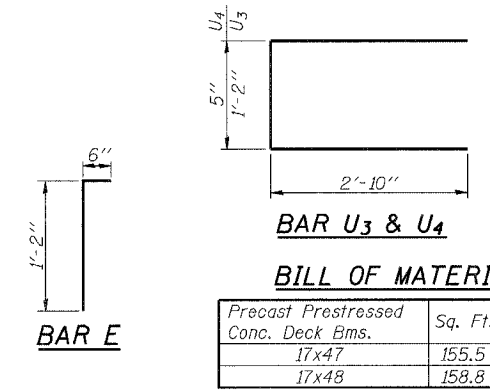

**BILL OF MATERIAL**

Precast Prestressed Conc. Deck Bms.	Sq. Ft.
17x47	155.5
17x48	158.8

**rjngroup**  
Excellence through Ownership  
200 West Front Street  
Wheaton, IL 60187

ILLINOIS DEPARTMENT OF TRANSPORTATION  
BEAM DETAILS - BEAMS 9 & 26  
U.S. ROUTE 52 OVER ELKHORN CREEK  
FAS RTE 2079 - OGLE COUNTY  
SECTION (16, 17, 18) RS-3 & (16BR)M-1  
STATION 971+50.04  
STRUCTURE NO. 071-0070  
DATE: 9/18/2007  
DRAWN BY: JMT  
CHECKED BY: BLB