

F.A.S. RTE.	SECTION	COUNTY	TOTAL SHEETS	SHEET NO.
2079	**	CARROLL & OGLE	232	124
STA.	TO STA.			
FED. ROAD DIST. NO.	ILLINOIS	FED. AID PROJECT		
(US 52)	** (16, 17, 18) RS-3 & (16) BRM-1			

DROP BOX NO. 4

RT STA. 187 + 50 (US 52)

CULVERT @ 70° SKEW

PLAN

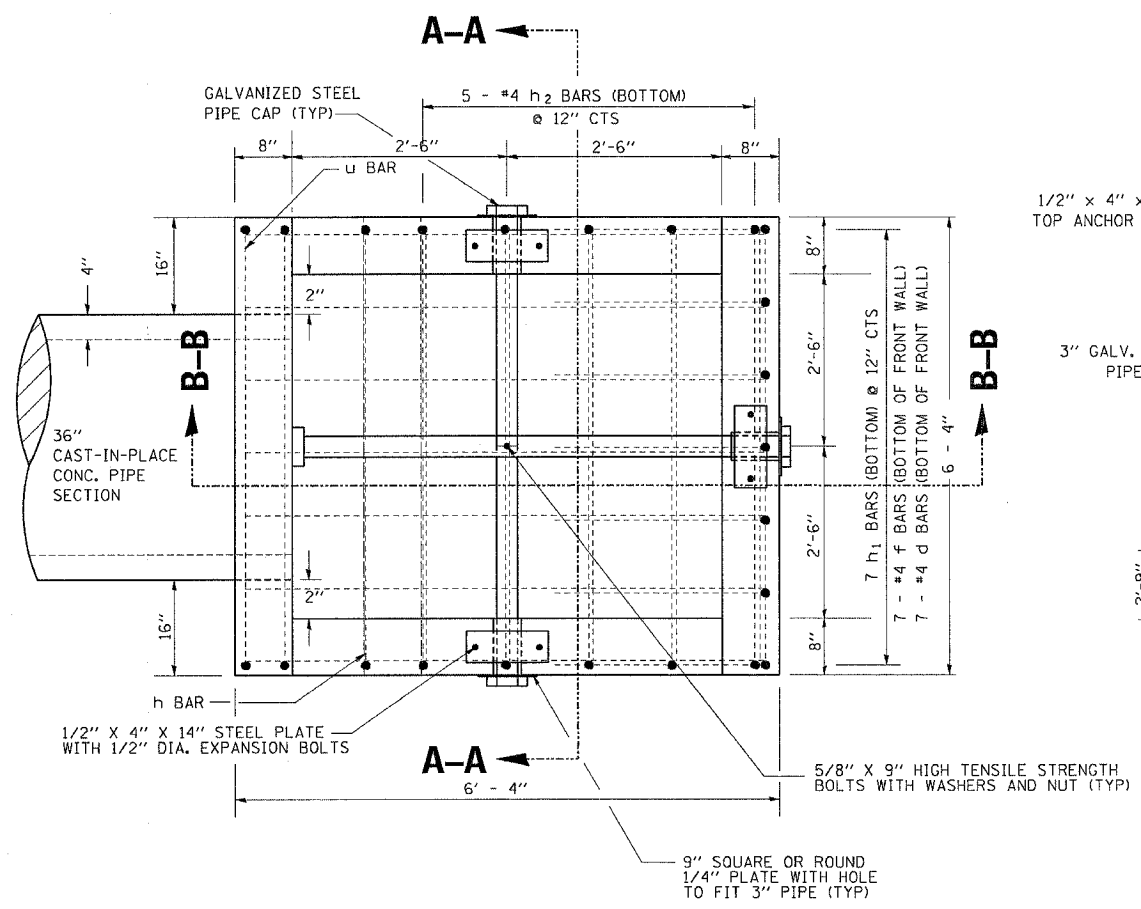

DETAIL "A"

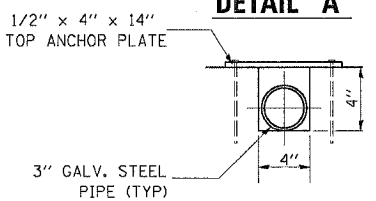

DETAIL "B"

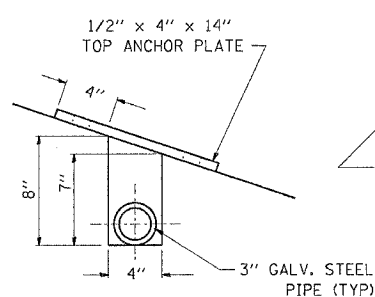

TOP ANCHOR PLATE

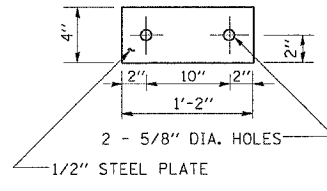

BAR f

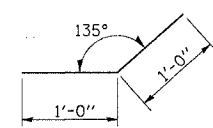

BAR d

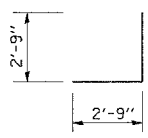

BAR d₁

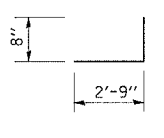

BAR z

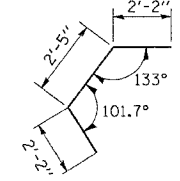

BAR u

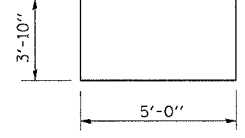

SECTION B-B

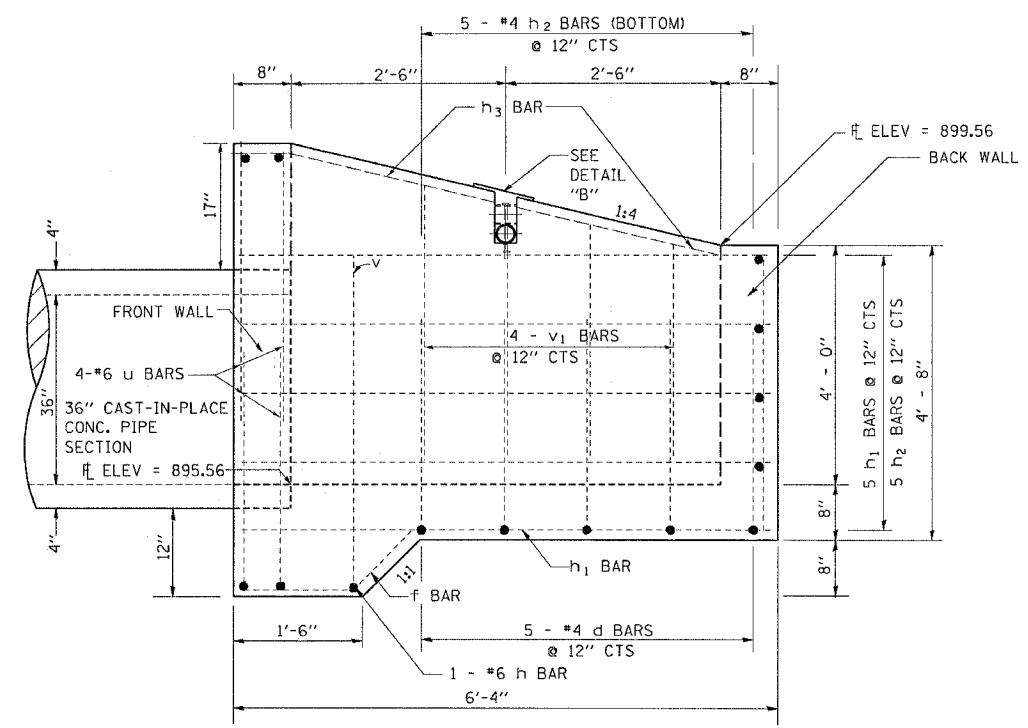

SECTION A-A

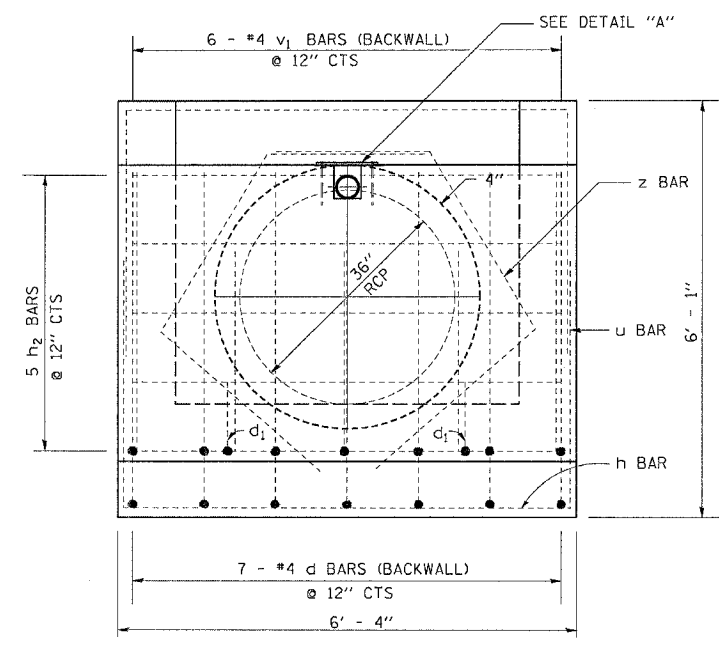

BILL OF MATERIALS (FOR REINFORCEMENT)

BAR	SIZE	NO.	LENGTH	WEIGHT (LB)
d	#4	17	6'-5"	72.87
d ₁	#4	2	3'-5"	4.56
f	#4	7	2'-0"	9.35
h	#6	1	6'-0"	9.01
h ₁	#4	15	6'-0"	60.12
h ₂	#4	9	6'-0"	36.07
h ₃	#4	4	2'-10"	7.56
u	#6	4	12'-8"	76.10
v	#4	2	5'-0"	6.68
v ₁	#4	8	2'-0"	10.69
z	#4	2	6'-9"	9.02
DESCRIPTION			UNIT	QTY
CLASS "SI" CONCRETE			CU YD	3.08
REINFORCEMENT BARS			LB	302.03

BILL OF MATERIALS (FOR GRATED DROP BOX No. 4)

DESCRIPTION	UNIT	QTY.
3" GALVANIZED STEEL PIPE	FOOT	1 @ 6'-4"
3" GALV PIPE CAPS	FOOT	1 @ 5'-8"
3" GALV PIPE CAPS	EACH	4
1/4" GALV. STEEL PLATE (9" NOMINAL)	EACH	3
1/2" X 4" X 14" GALV. STEEL PLATE	EACH	3
5/8" X 9" GALV. STEEL BOLTS	EACH	1
EXPANSION BOLTS 1/2"Ø	EACH	6

GENERAL NOTES:

- THIS WORK SHALL BE PAID FOR AT THE CONTRACT UNIT PRICE PER EACH FOR DROP BOX NO. 4.
- SLOPE FLOW LINE FOR DROP BOX NO. 4 IS THE SAME RATE AS THE FLOW LINE OF THE PIPE.
- BOLTS, NUTS, AND WASHERS SHALL BE IN ACCORDANCE WITH ARTICLE 1006.08 OF THE STANDARD SPECIFICATION AND SHALL BE GALVANIZED.
- STEEL PIPES SHALL CONFORM TO A.S.T.M. A-53 (TYPE E OR S) GRADE B, SCHEDULE 40, AND SHALL BE GALVANIZED CONFORMING TO A.S.T.M. A-120. CONTRACTOR SHALL FIELD VERIFY PIPE LENGTH.
- STEEL PLATES SHALL CONFORM TO AASHTO M-183 AND SHALL BE GALVANIZED CONFORMING TO AASHTO M-111.
- REINFORCEMENT BARS SHALL CONFORM TO THE REQUIREMENTS OF AASHTO M 31 OR M 322, GRADE 40 OR 60.
- SEE PLAN AND PROFILE SHEET FOR MORE INFORMATION. SEE CROSS SECTION SHEET FOR MORE INFORMATION.

PLOT DATE = Wed Mar 07 13:56:57 2007
 FILE NAME = c:\p1\2006\187+50\187+50\187+50.dgn
 PLOT SCALE = 50.000000 / 1.00
 USER NAME = dssidd