

F.A.P. RTE.	SECTION	COUNTY	TOTAL SHEETS	SHEET NO.
*595	5HR	ROCKISLAND	139	98
STA.		TO STA.		
FED. ROAD DIST. NO.		ILLINOIS		FED. AID PROJECT
*CL 5/IL 92				

# DETAIL OF HOT-MIX ASPHALT SHOULDER AT GUARD RAIL

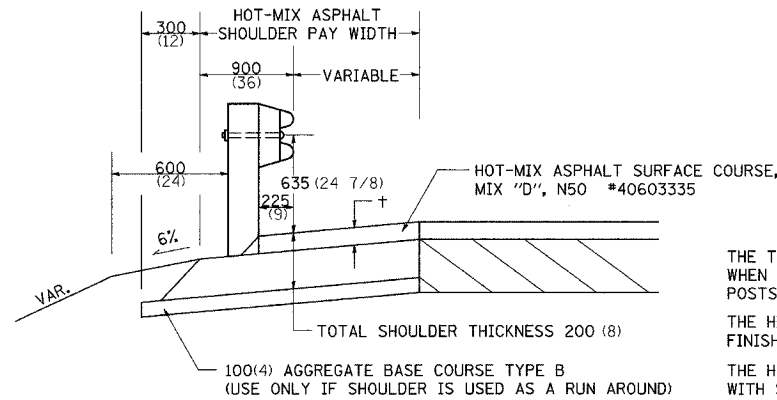

† = SEE TYPICAL SECTIONS FOR THICKNESS

### GENERAL NOTES

THE TOP LIFT SHALL NOT BE PLACED BEHIND THE GUARDRAIL POSTS. WHEN PLACING THE TOP LIFT THE RAIL MUST BE REMOVED FROM THE POSTS. THE POST SHALL NOT BE REMOVED.

THE HEIGHT OF THE GUARD RAIL SHALL BE SET 525 (21) FROM THE FINISHED SURFACE.

THE HOT-MIX ASPHALT SHOULDER SHALL BE CONSTRUCTED IN ACCORDANCE WITH SECTION 482 EXCEPT THE TOP LIFT SHALL BE HOT-MIX ASPHALT SURFACE COURSE, MIXTURE "D", N50. THE WORK WILL BE PAID FOR AT THE CONTRACT UNIT PRICE PER TON FOR HOT-MIX ASPHALT SURFACE COURSE, MIXTURE "D", N50 AND SQUARE METER (SQUARE YARD) FOR HOT-MIX ASPHALT SHOULDERS OF THE THICKNESS SPECIFIED. THE REMOVAL & REINSTALLATION OF THE GUARDRAIL WILL BE INCLUDED IN THE COST OF THE HOT-MIX ASPHALT SURFACE COURSE, MIXTURE "D", N50.

ALL DIMENSIONS ARE IN MILLIMETERS (INCHES) UNLESS OTHERWISE NOTED.

## DETAIL OF HOT-MIX ASPHALT SHOULDER AT GUARD RAIL 23.4

REVISED 10-06-06

# HOT-MIX ASPHALT SHOULDER

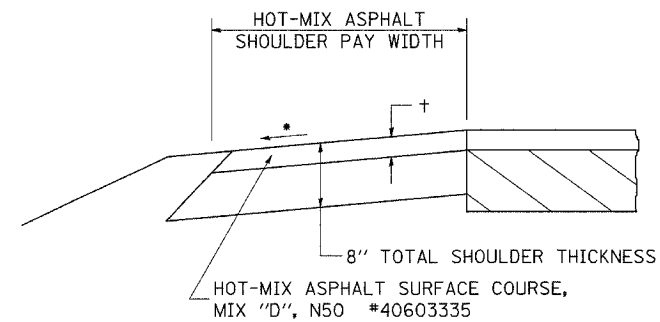

† = SEE TYPICAL SECTIONS FOR THICKNESS

ALL DIMENSIONS ARE IN MILLIMETERS (INCHES) UNLESS OTHERWISE NOTED.

### GENERAL NOTES

THE HOT-MIX ASPHALT SHOULDER SHALL BE CONSTRUCTED IN ACCORDANCE WITH SECTION 482 EXCEPT THE TOP LIFT SHALL BE HOT-MIX ASPHALT SURFACE COURSE, MIX "D", N50 #40603335. THE WORK WILL BE PAID FOR AT THE CONTRACT UNIT PRICE PER TON FOR HOT-MIX ASPHALT SURFACE COURSE, MIX "D", N50 #40603335 AND SQUARE YARD FOR HOT-MIX ASPHALT SHOULDERS OF THE THICKNESS SPECIFIED. USE HOT-MIX ASPHALT SURFACE COURSE, MIX "D", N50 #40603335. WHEN RESURFACING EXISTING HOT-MIX ASPHALT SHOULDERS. THE THICKNESS IS SHOWN ON THE TYPICAL SECTIONS. THIS WORK WILL BE PAID FOR AT THE CONTRACT UNIT PRICE PER TON FOR HOT-MIX ASPHALT SURFACE COURSE, MIX "D", N50 #40603335. REMOVAL OF MATERIAL FOR PLACEMENT OF THE HOT-MIX ASPHALT SHOULDER TO BE PAID FOR IN UNITS FOR EXCAVATING AND GRADING EXISTING SHOULDERS OR IN CUBIC YARDS FOR EARTH EXCAVATION OR EARTH EXCAVATION WIDENING.

\*4% WHEN MAINLINE IS ON TANGENT. FOR CROSS SLOPE ON SUPERELEVATION SECTION, SEE HIGHWAY STANDARD 482001 OR 482006.

## HOT-MIX ASPHALT SHOULDER 23.4a

REVISED 10-06-06

# DELINEATION OF CENTER BARRIER OF TWO-LANE TWO WAY OPERATION

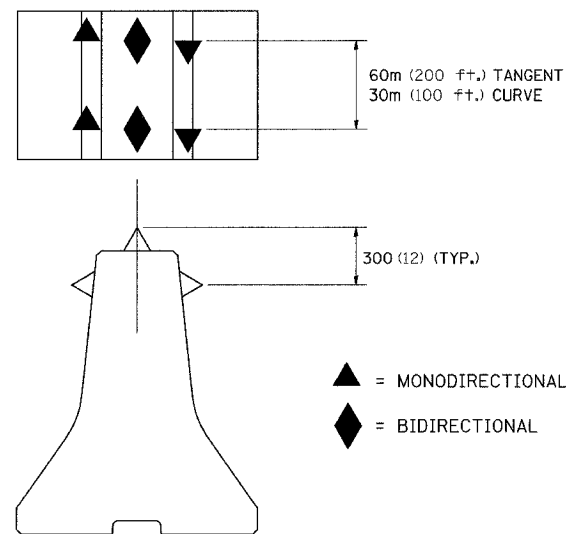

### DESIGNER NOTE:

Use this with Traffic Control and Protection Standard 701416 when using concrete barrier vs. flexible delineators as the barrier on centerline.

### NOTES

- All reflectors are to be amber in color and meet the specifications of Section 1097 of the Standard Specifications for Road and Bridge Construction.
- All reflectors are to be installed in accordance with Section 782 of the Standard Specifications for Road and Bridge Construction.
- On Interstates do not use the panels mounted on top of the barriers as shown on Standard 701416.
- The cost of the reflectors will be included in the contract unit price per meter (foot) for Temporary Concrete Barrier.
- ALL DIMENSIONS ARE IN MILLIMETERS (INCHES) UNLESS OTHERWISE NOTED.

## DELINEATION OF CENTER BARRIER OF TWO-LANE TWO WAY OPERATION 25.4

REVISED 10-10-06

# CONCRETE HEADWALLS FOR PIPE DRAINS

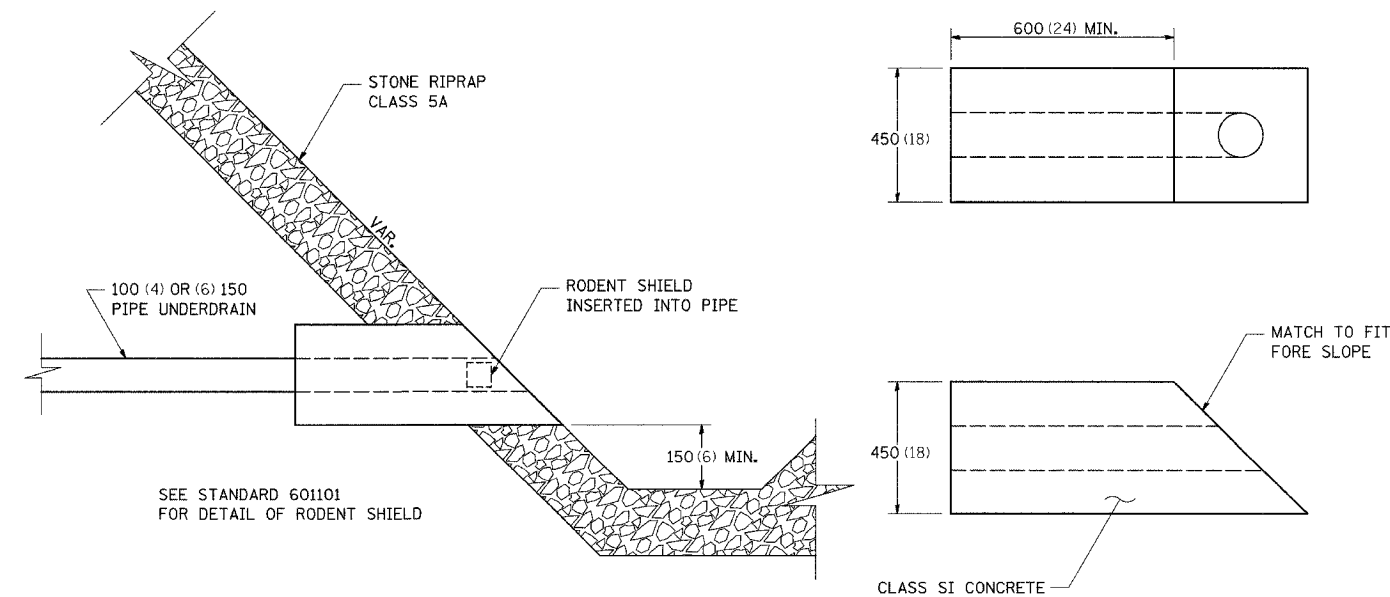

ALL DIMENSIONS ARE IN MILLIMETERS (INCHES) UNLESS OTHERWISE NOTED.

## CONCRETE HEADWALLS FOR PIPE DRAINS 27.4

REVISED 10-15-04