

ROUTE NO.	SECTION	COUNTY	TOTAL SHEETS	SHEET NO.
F.A.P. 310 U.S. 67	(40BY)BR, (41-A)BR-1	McDonough	66	20
FED. ROAD DIST. NO. 4		FED. AID PROJECT		

SHEET NO. 3
14 SHEETS

Contract #68677

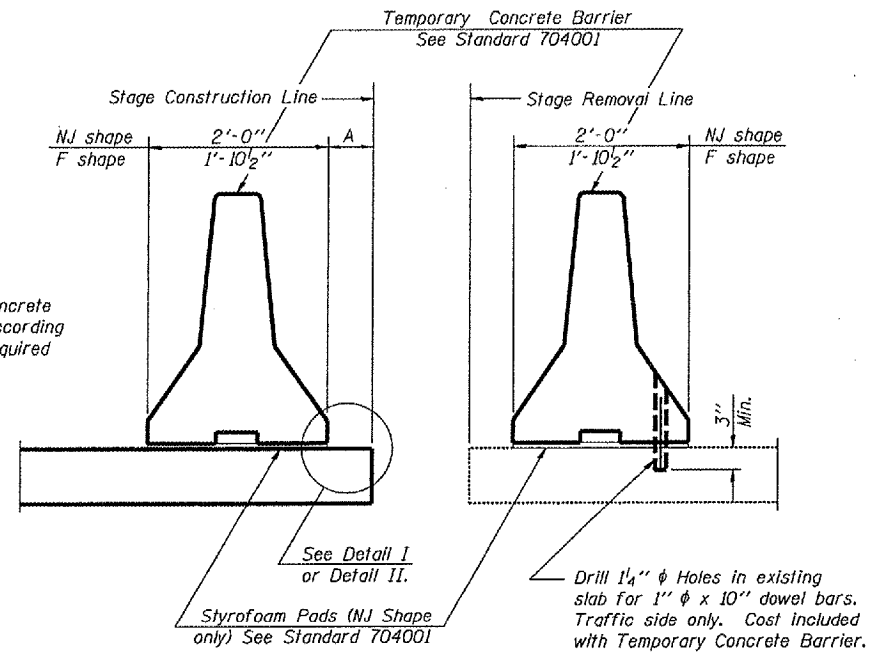

When "A" is 3'-6" or less, the temporary concrete barrier shall be anchored to the new slab according to Detail I or Detail II. No anchorage is required when "A" is greater than 3'-6".

NOTES

- Detail I - With Bar Splicer or Couplers:
Connect one (1) 1"x7"x10" steel P to the top layer of couplers with 2-5/8" φ bolts screwed to coupler at approximate C of each barrier panel.
 - Detail II - With Extended Reinforcement Bars:
Connect one (1) 1"x7"x10" steel P to the concrete slab with 2-5/8" φ Expansion Anchors or cast in place inserts spaced between the top layer of reinforcement at approximate C of each barrier panel.
- Cost of anchorage is included with Temporary Concrete Barrier.

NEW SLAB

EXISTING SLAB

SECTIONS THRU SLAB

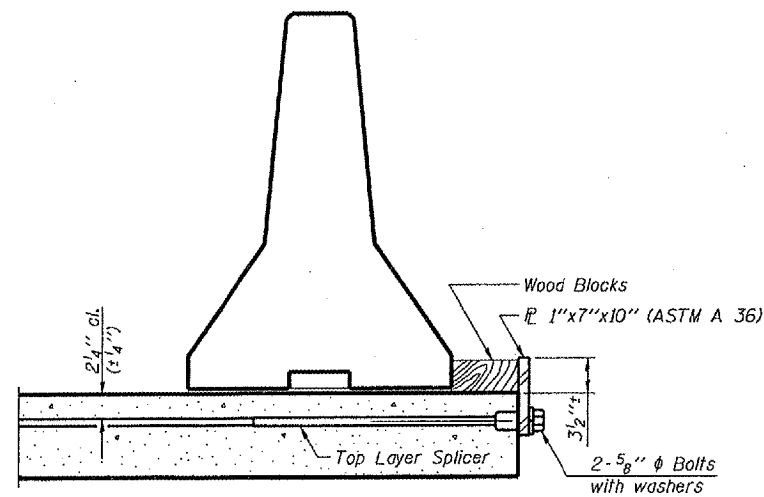

DETAIL I

The 1"x7"x10" Plate shall not be removed until Stage II Construction forms and reinforcement bars are in place.

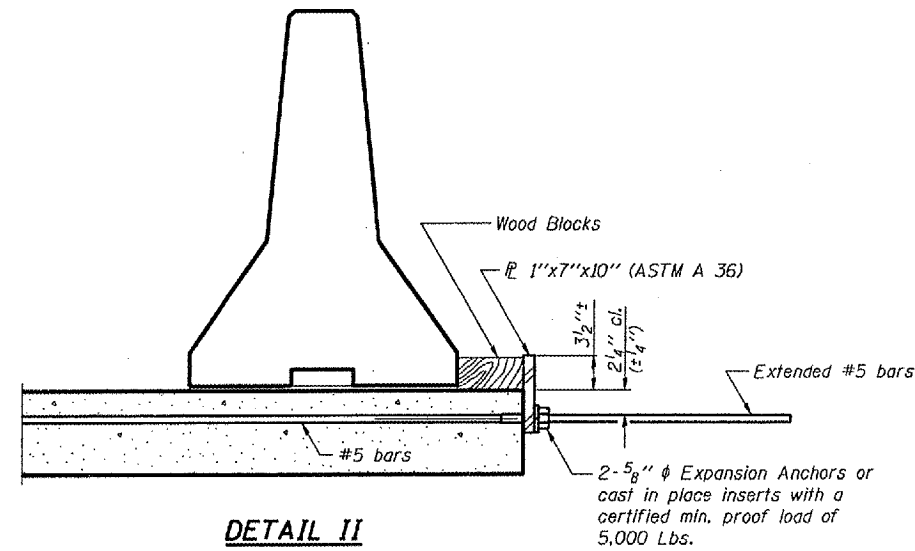

DETAIL II

The 1"x7"x10" Plate shall not be removed until Stage II Construction forms and all reinforcement bars are in place and the concrete is ready to be placed.

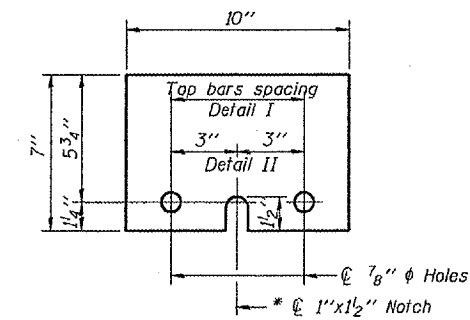

P 1"x7"x10"

* Required only with Detail II

**TEMPORARY CONCRETE BARRIER FOR
STAGE CONSTRUCTION
F.A.P. 310, SECTION (41A)BR-1
U.S. ROUTE 67 OVER GRINDSTONE CREEK
MCDONOUGH COUNTY
STA. 454+20 (S.N. 055-0049)**

WHA # 1050003