

STATE OF ILLINOIS
DEPARTMENT OF TRANSPORTATION

ROUTE NO.	SECTION	COUNTY	STATION	SHEET	SHEET NO. 8 16 SHEETS
FAP 132	1BR-2	SALINE	114	50	
ILLINOIS FEDERAL PROJECT					

78010

NOTES

- After beams have been erected, holes shall be drilled into substructure and dowels rods placed. Dowel holes shall be filled with non-shrink grout to top of beam and allowed to cure min. 24 hrs. prior to grouting the shear keys.
- Concrete wearing surface to be poured after grouting the shear keys.
- Dowel rods drilled in cap are included in the cost of Precast Prestressed Concrete Deck Beams (27" depth).
- The rail anchorage shall be cast with the beam or approach pavement and the wearing surface shall be cast in the field. Formwork necessary for the wearing surface may be secured utilizing the bottom rail anchorage inserts and/or additional inserts cast into the beam or approach pavement. Drilling into the beam will not be permitted.
- Anchor bolts shall be ASTM F1554 all-thread (or an Engineer-approved alternate material) of the grade(s) and diameter(s) specified. ASTM A307 Grade C anchor bolts may be used in lieu of ASTM F1554 Grade 36 (Fy=36ksi). The corresponding specified grade of AASHTO M314 anchor bolts may be used in lieu of ASTM F1554.
- Anchor bolts for side retainers may be cast in place or installed in holes drilled before or after members are in place.
- Drilled and set anchor bolts shall be installed according to Article 521.06 of the Standard Specifications.

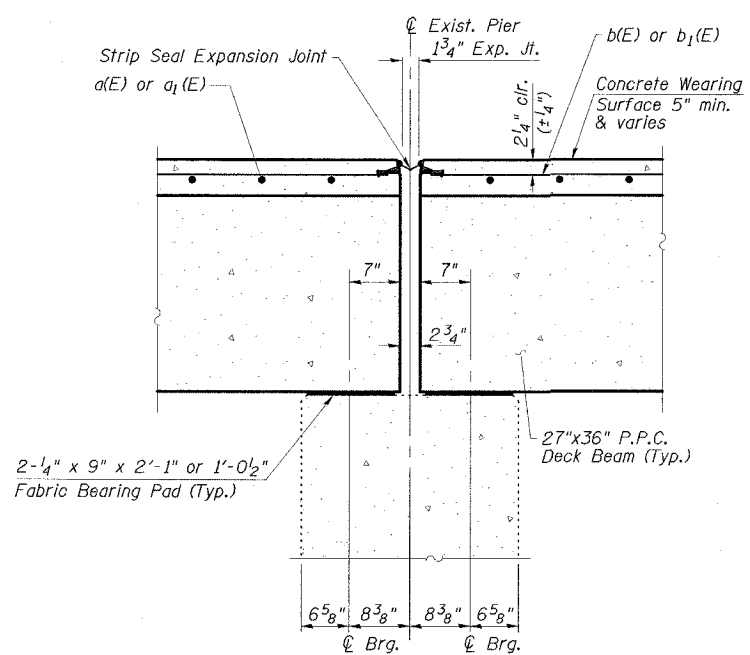

SECTION THRU PIER

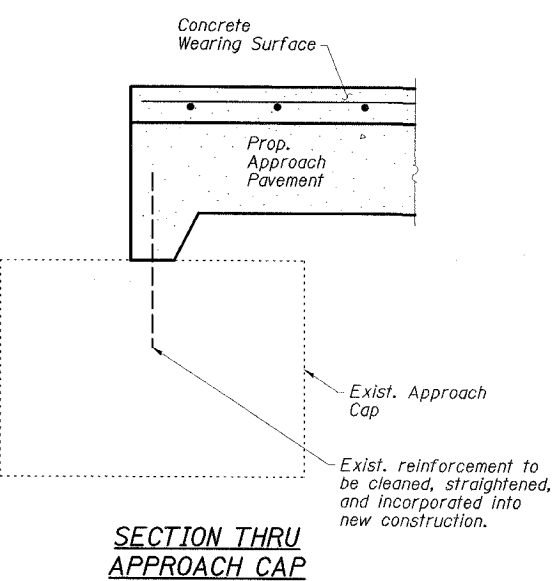

SECTION THRU APPROACH CAP

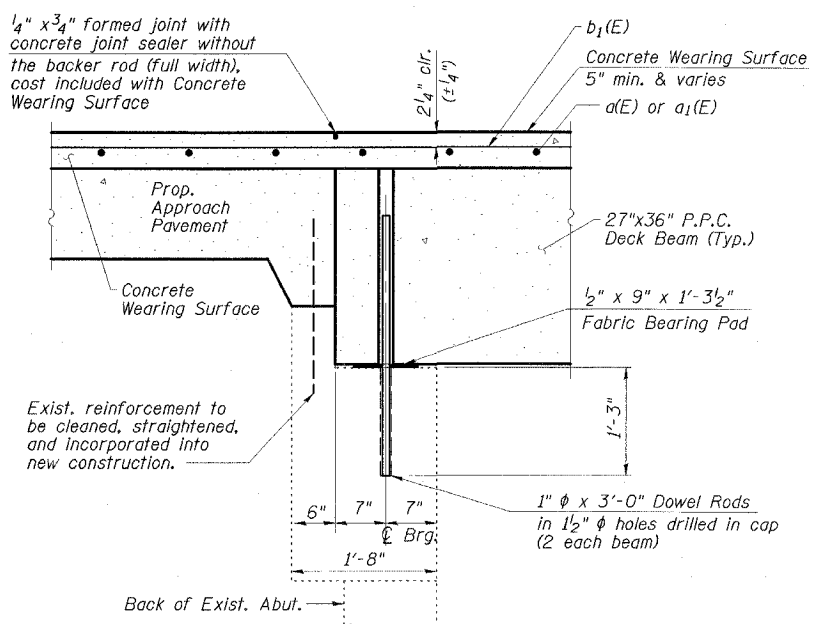

SECTION THRU ABUTMENT @ OUTSIDE BEAM

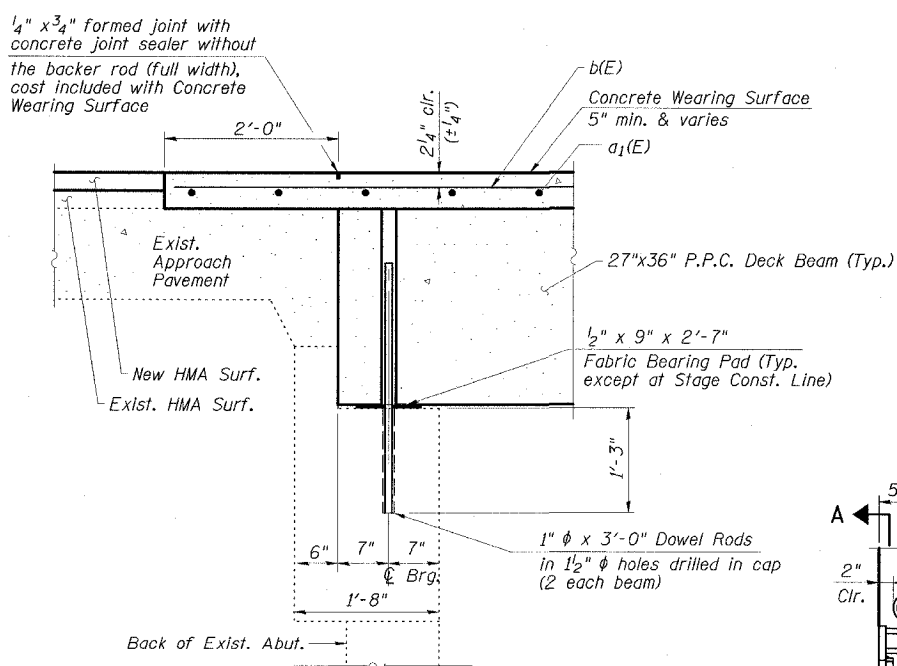

SECTION THRU ABUTMENT @ ROADWAY

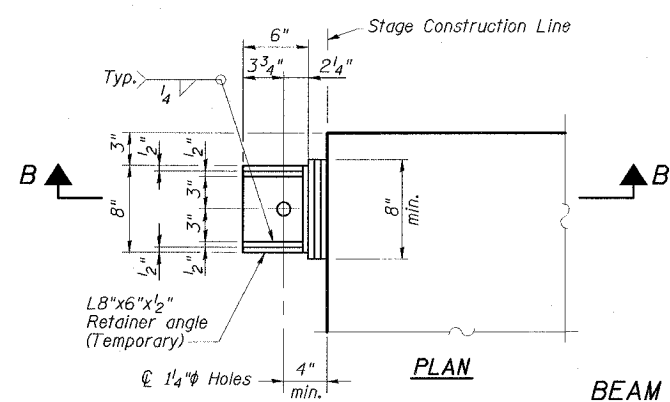

BEAM RETAINER DETAILS AT STAGE CONSTRUCTION LINE (2 Required)

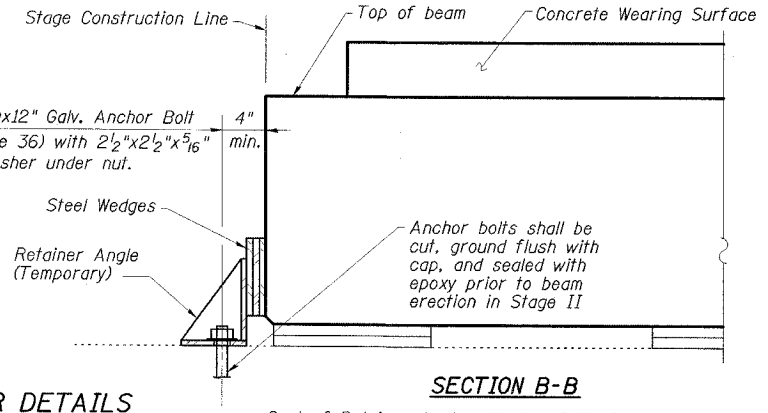

SECTION B-B

Cost of Retainer Angles, Anchor Bolts & accessories is included with Precast Prestressed Concrete Deck Beams.

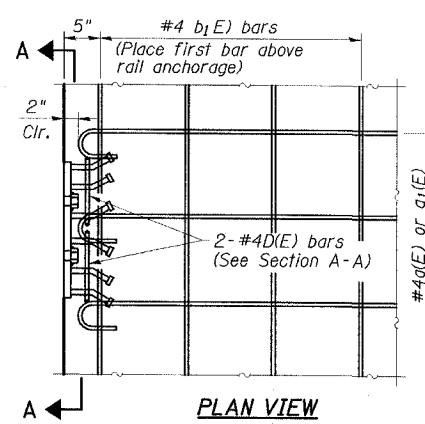

PLAN VIEW

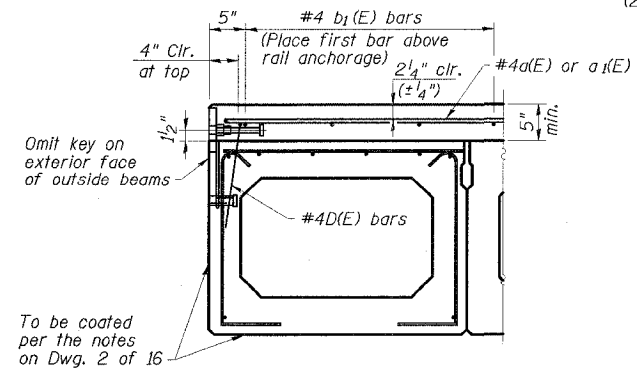

FASCIA BEAM CROSS SECTION

CONCRETE OVERLAY MODIFICATIONS FOR RAIL ANCHORAGE (Bridge shown, Approach similar)

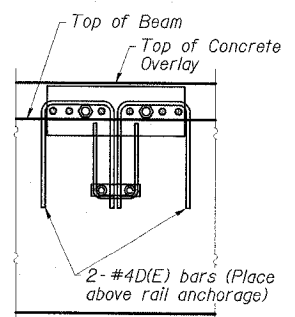

SECTION A-A

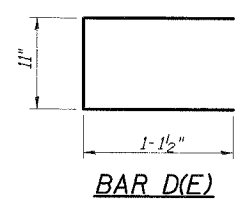

BAR D(E)

SUPERSTRUCTURE AND APPROACH DETAILS
IL 34/145 OVER SOUTH FORK SALINE RIVER
FAP ROUTE 134 - SECTION 1BR-2
SALINE COUNTY
STATION 235+10.00
STRUCTURE NO. 083-0019

ESCA
CONSULTANTS, INC.

DESIGNED BY:	JMS	05/07
DRAWN BY:	HAS	05/07
CHECKED BY:	MTD	06/07
APPROVED BY:	RDP	06/07