

STATE OF ILLINOIS
DEPARTMENT OF TRANSPORTATION

ROUTE NO.	SECTION	COUNTY	LEVEE	POST	SHEET NO. 2 16 SHEETS
FAP 132	1BR-3	SALINE	114	67	
FED. ROAD DIST. NO.	ILLINOIS	FED. AID PROJECT			

78010

GENERAL NOTES

1. Reinforcement bars shall conform to the requirements of ASTM A706 Gr 60 (IL Modified). See Special Provisions.
2. Plan dimensions and details relative to existing plans are subject to routine variations. The Contractor shall field verify existing dimensions and details affecting new construction and make necessary approved adjustments prior to construction or ordering of materials. Such variations shall not be cause for additional compensation for a change in scope of the work. However, the Contractor will be paid for the quantity actually furnished based upon the unit price bid for the work.
3. Concrete Sealer shall be applied to abutment bearing seats where Structural Repair of Concrete is performed.
4. All new structural steel shall be shop painted with an inorganic zinc rich primer per AASHTO M300 Type 1 unless noted otherwise.
5. No in-stream work will be allowed on this project.
6. The Contractor is advised that the existing PPC Deck Beams are in a deteriorated condition with reduced load carrying capacity. It is the Contractor's responsibility to account for the condition of the beams when developing construction procedures for removal and replacement of the superstructure.
7. If the Contractor's procedures for existing beam removal or placement of new beams involves placement of heavy equipment on the new or existing deck beams, a detailed procedure shall be submitted to the Engineer for approval. The procedure shall include calculations, sealed by an Illinois Licensed Structural Engineer, verifying the structural adequacy of the beams for the proposed loads. Cost included with Removal of Existing Superstructures No. 3.
8. The minimum thickness of the concrete overlay shall be 5" and varies as required to adjust for the new profile grade and beam camber.
9. Repair of the substructure shall be completed prior to placement of the new deck beams.
10. Stage Construction of Precast Prestressed Concrete Deck Beams shall be according to Article 504.06(d) of the Standard Specifications.

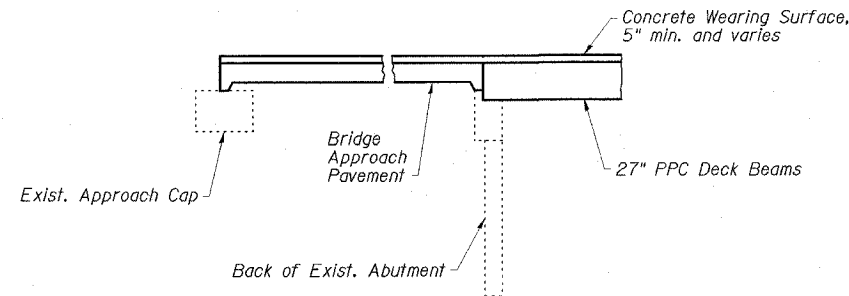

SECTION THRU ABUTMENTS
○ OUTSIDE BEAM

TOTAL BILL OF MATERIAL

ITEM	UNIT	SUPER	SUB	TOTAL
Bridge Approach Pavement (Special)	Sq. Yd.	26	-	26
Removal of Existing Superstructures No. 2	Each	1	-	1
Bridge Deck Grooving	Sq. Yd.	491	-	491
Protective Coat	Sq. Yd.	491	-	491
Precast Prestressed Concrete Deck Beams (27" Depth)	Sq. Ft.	3944	-	3944
Reinforcement Bars, Epoxy Coated	Pound	6370	-	6370
Bar Splicers	Each	124	-	124
Steel Railing, Type SM	Foot	343	-	343
Name Plates	Each	1	-	1
Preformed Joint Strip Seal	Foot	33	-	33
Concrete Sealer	Sq. Ft.	-	45	45
Epoxy Crack Injection	Foot	-	120	120
Structural Repair of Concrete (Depth Equal to or Less Than 5")	Sq. Ft.	-	69	69
Concrete Wearing Surface, 5"	Sq. Ft.	491	-	491
Asbestos Bearing Pad Removal	Each	-	44	44

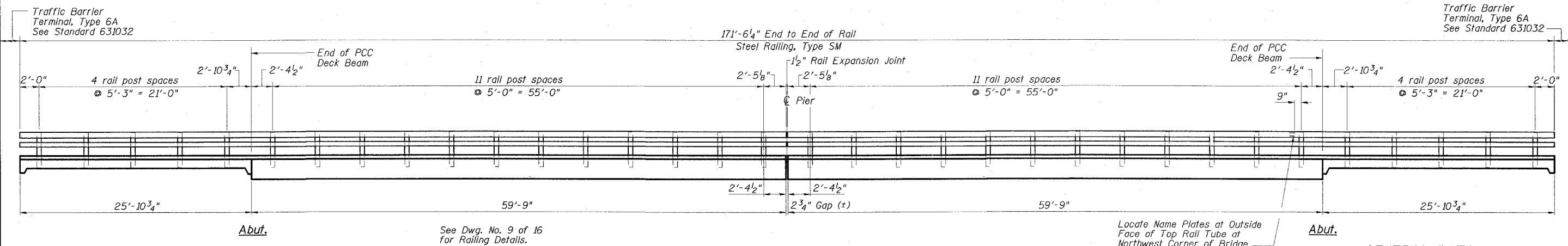

RAILING ELEVATION
(Showing Inside Face of East Railing;
West Railing Similar)

Locate Name Plates at Outside
Face of Top Rail Tube at
Northwest Corner of Bridge

GENERAL DATA
IL 34/145 OVER SOUTH FORK
SALINE RIVER OVERFLOW
FAP ROUTE 132 - SECTION 1BR-3
SALINE COUNTY
STATION 244+40.00
STRUCTURE NO. 083-0020

ESCA
CONSULTANTS, INC.

DESIGNED BY:	JMS	05/07
DRAWN BY:	HAS	05/07
CHECKED BY:	MTD	06/07
APPROVED BY:	RDP	06/07