

STATE OF ILLINOIS
DEPARTMENT OF TRANSPORTATION

ROUTE NO.	SECTION	COUNTY	SHEET NO.	SHEET NO.
FAP 132	IBR-3	SALINE	114	75
FED. ROAD DIST. NO.		ILLINOIS	FED. AID PROJECT	
78010				

SHEET NO. 10
16 SHEETS

GENERAL NOTES

The strip seal shall be made continuous and shall have a minimum thickness of 1/4". The configuration of the strip seal shall match the configuration of the Locking Edge Rails.

The height and thickness of the Locking Edge Rails shown are minimum dimensions. The actual configuration of the Locking Edge Rails and matching strip seal may vary from manufacturer to manufacturer. Flanged edge rails will not be allowed.

Locking Edge Rails may be spliced at slope discontinuities and stage construction joints.

The manufacturer's recommended installation methods shall be followed.

All steel components shall be galvanized after fabrication according to Article 520.03 of the Standard Specifications.

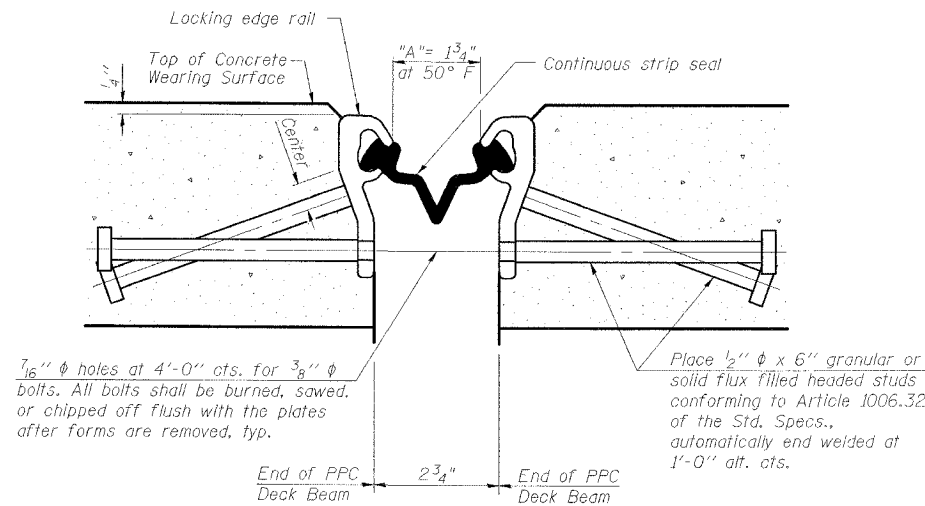

**SECTION THRU STRIP SEAL JOINT
FOR OVERLAY OVER DECK BEAMS**

Required Strip Seal rated movement	"A"
1"	1 1/8"
2"	1 3/4"

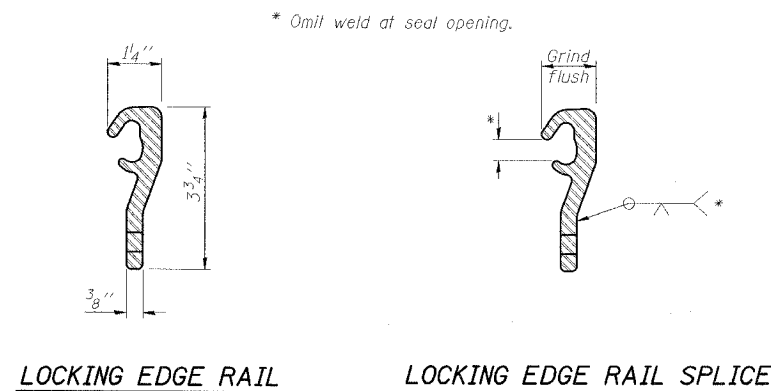

ESCA
CONSULTANTS, INC.

DESIGNED BY:	JMS	05/07
DRAWN BY:	HAS	05/07
CHECKED BY:	MTD	06/07
APPROVED BY:	RDP	06/07

**STRIP SEAL EXPANSION JOINT
IL 34/145 OVER SOUTH FORK
SALINE RIVER OVERFLOW
FAP ROUTE 132 - SECTION IBR-3
SALINE COUNTY
STATION 244+40.00
STRUCTURE NO. 083-0020**