

**STATE OF ILLINOIS  
DEPARTMENT OF TRANSPORTATION**

ROUTE NO.	SECTION	COUNTY	SHEETS	DATE
FAP 332	*	WHITE	13	11
FED. ROAD DIST. NO. 7	ILL. DIST.	FED. AID PROJECT		

Contract # 78015  
\* D9 CM BRIDGE REPAIR FY 08-1

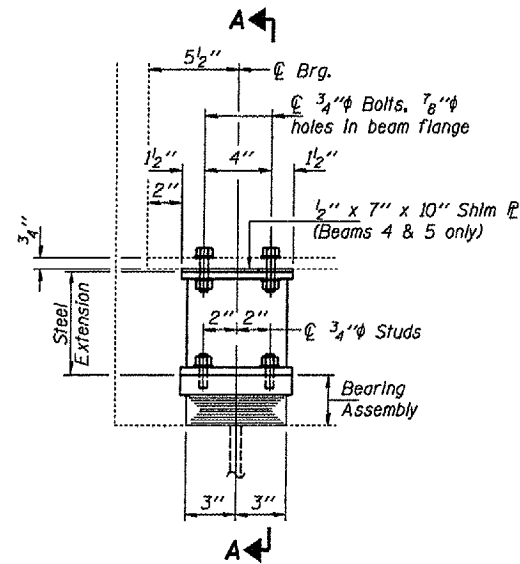

**ELEVATION AT ABUTMENT**

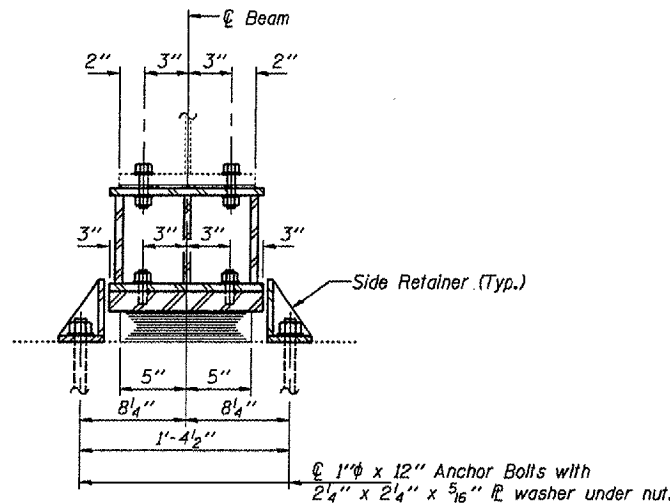

**SECTION A-A**

**TYPE I ELASTOMERIC EXP. BRG.**

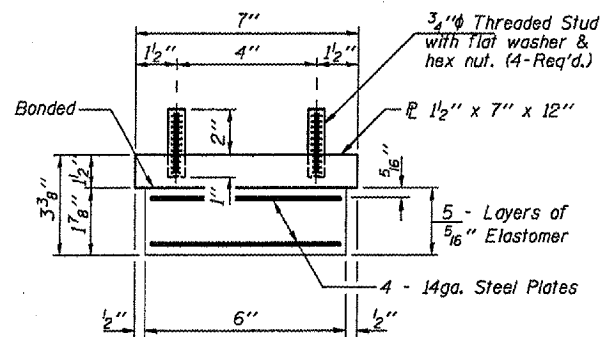

**BEARING ASSEMBLY**

Note:  
Shim plates shall not be placed under Bearing Assembly.

**BEAM REACTIONS**

RP	(K)	11.7
R <sub>L</sub>	(K)	26.5
Imp.	(K)	8.0
R (Total)	(K)	46.2

Notes:  
Diaphragm removal and reinstatement may be required to facilitate drilling holes. Cost included with Furnishing and Erecting Structural Steel.  
New steel extensions, shim plates and connection bolts are included with Furnishing and Erecting Structural Steel.  
Prior to ordering any material, the Contractor shall verify in the field all bearing height and shim thickness dimensions. Min. jack capacity = 25 Tons.  
Anchor bolts shall be ASTM F1554 all-thread (or an Engineer-approved alternate material) of the grade(s) and diameter(s) specified. ASTM A307 Grade C anchor bolts may be used in lieu of ASTM F1554 Grade 36 (Fy=36ksi). The corresponding specified grade of AASHTO M314 anchor bolts may be used in lieu of ASTM F1554.  
Drilled and set anchor bolts shall be installed according to Article 521.06 of the Standard Specifications.  
Side retainers shall be included in the cost of Elastomeric Bearing Assembly, Type I.

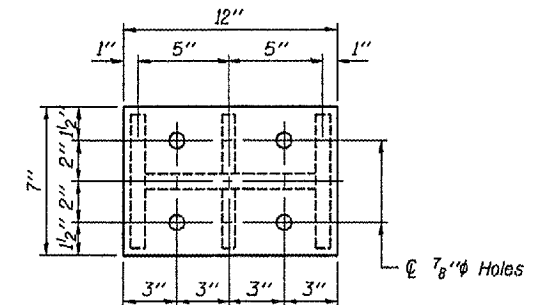

**PLAN TOP AND BOTTOM PLATE**

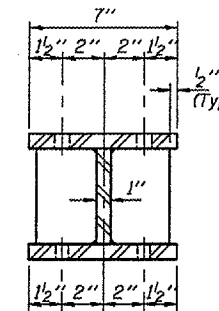

**SECTION B-B**

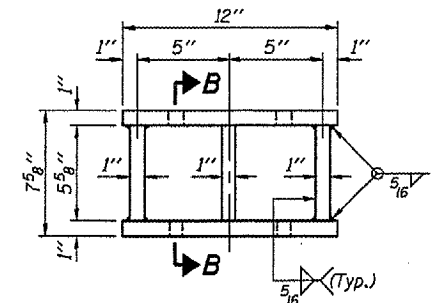

**STEEL EXTENSION DETAIL**

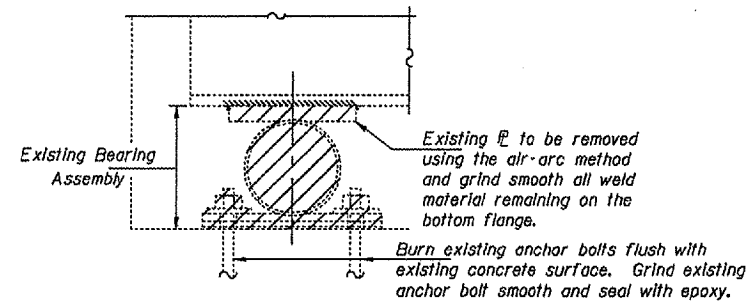

**EXISTING BEARING REMOVAL DETAIL**

Cost included with Jack and Remove Existing Bearings.

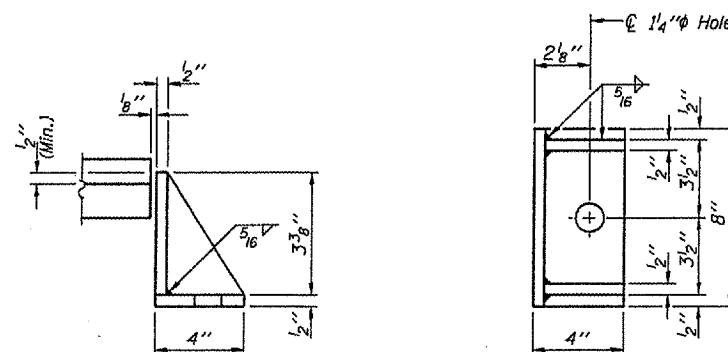

**SIDE RETAINER**

Equivalent rolled angle with stiffeners will be allowed in lieu of welded plates.

**BILL OF MATERIAL**

Item	Unit	Total
Elastomeric Bearing Assembly Type I	Each	16
Jack and Remove Existing Bearings	Each	16
Furnishing and Erecting Structural Steel	Pound	1530
Anchor Bolts	Each	32

DESIGNED	DAB
CHECKED	AJB
DRAWN	baliva
CHECKED	DAB AJB

TYI/REPS 11-01-2006

**BRIDGE REPAIRS  
FAP 332 OVER FRENCH CREEK  
WHITE COUNTY  
SN 097-0005**