

CONTRACT NO. 60B39

NOTE
 * MAXIMUM POST SPACING SHALL BE 3 m (10') C&C EXCEPT WHERE OTHERWISE SHOWN ON PLANS

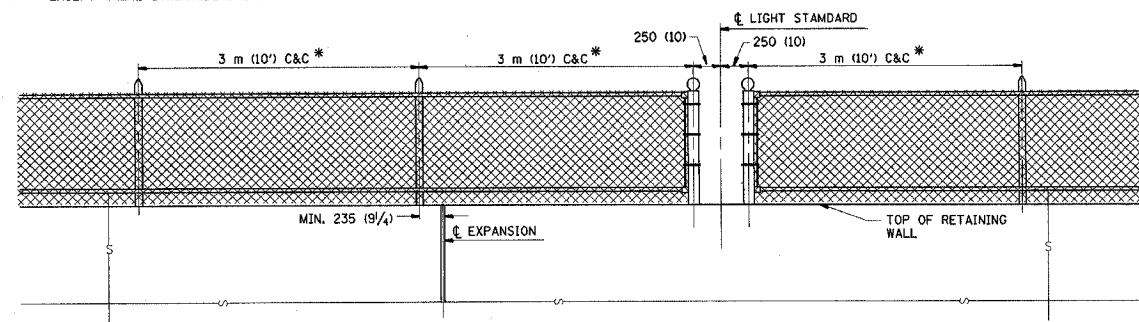

ELEVATION VIEW OF RETAINING WALL WITH PEDESTRIAN BARRIER TYPE III

FOR INFORMATIONAL PURPOSES ONLY

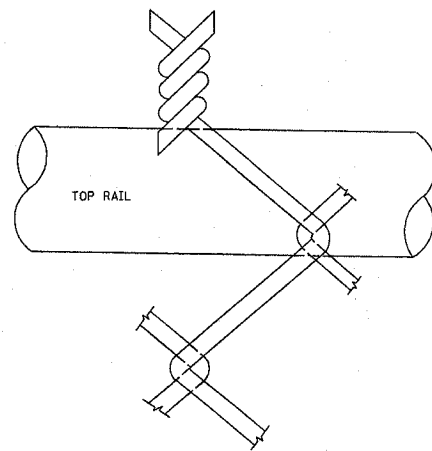

WIRE MESH FABRIC TO BE BARBED AT THE TOP

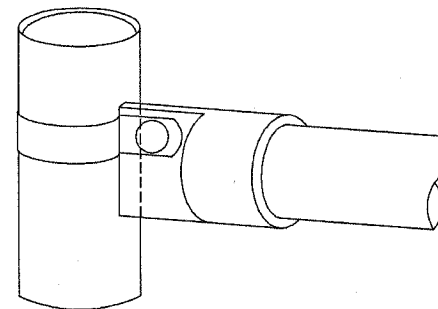

RAIL FITTING AT END POSTS

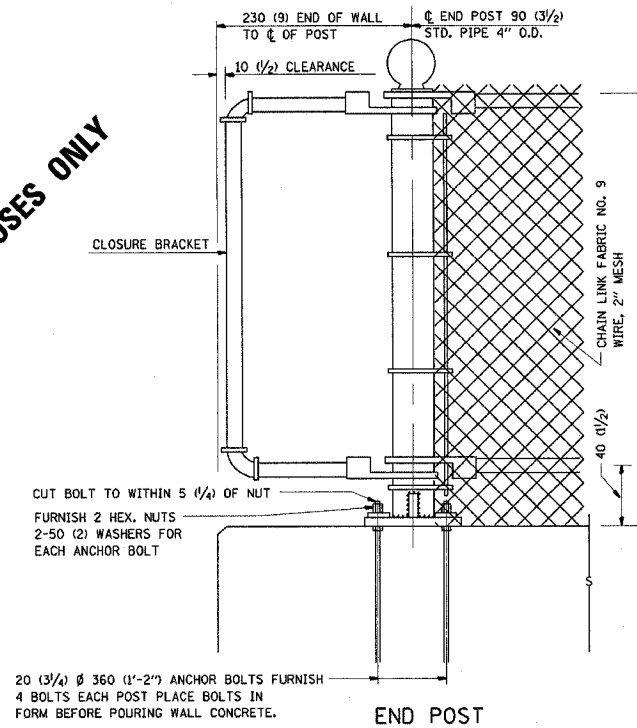

20 (3/4) ϕ 360 (1'-2") ANCHOR BOLTS FURNISH 4 BOLTS EACH POST PLACE BOLTS IN FORM BEFORE POURING WALL CONCRETE.

NOTE:
 THE COST OF FURNISHING ANCHOR BOLTS, NUTS, & WASHERS TO BE INCIDENTAL

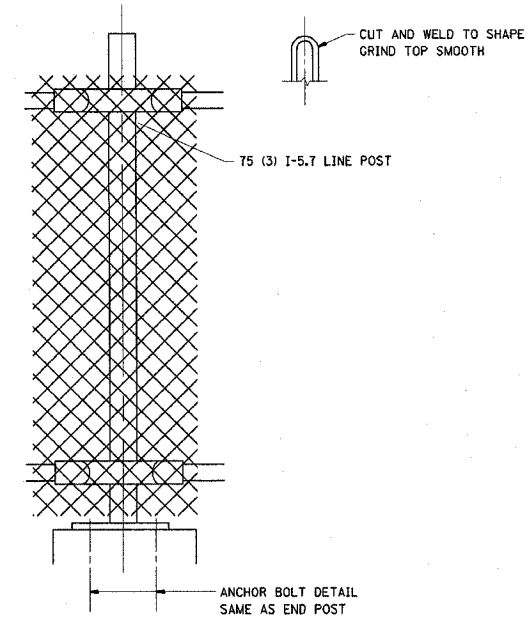

LINE POST

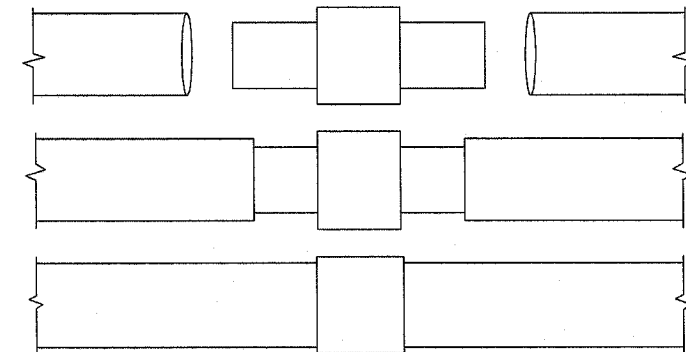

EXPANSION COUPLING DETAIL

NOTE:
 EXP. COUPLING TO APPEAR IN TOP AND BOTTOM RAILS WHERE EVER EXP. JT. APPEARS IN STRUCTURE.

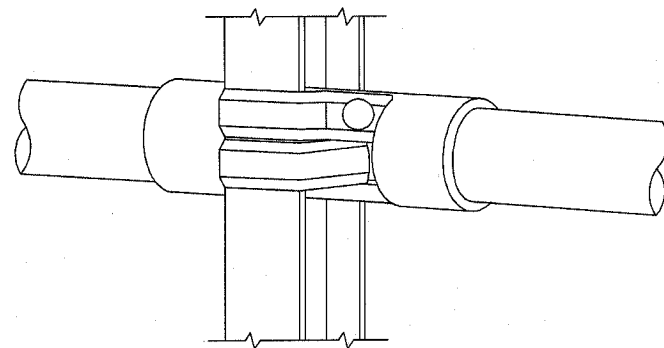

RAIL FITTING ON SECTION LINE POST

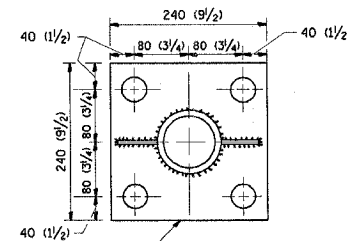

240 (9 1/2) X 80 (3 1/4) X 240 (9 1/2) BASE PLATE
 4-30 (1 1/4) ϕ HOLES FOR END ϕ LINE POSTS

ANCHOR PLATE DETAILS

NOTE:
 POST, PLATE AND GUSSET ASSEMBLY SHALL BE GALVANIZED AFTER ALL CUTTING, DRILLING, WELDING, AND FABRICATION HAVE BEEN COMPLETED. THE GALVANIZED COATING SHALL CONFORM TO THE REQUIREMENTS OF AASHTO M 120. THE GALVANIZED COATING SHALL NOT BE LESS THAN 610 G/50 M (2.0 OZ./50. FT.) OF SURFACE.

ALL DIMENSIONS ARE IN MILLIMETERS (INCHES) UNLESS OTHERWISE SHOWN.

ILLINOIS DEPARTMENT OF TRANSPORTATION

PEDESTRIAN BARRIER TYPE III
 STD. 10-SS-514 R

REVISIONS	
NAME	DATE

SCALE: NONE
 DATE: 9/28/2006

DRAWN BY: C.A.D.D.
 CHECKED BY: