

NOTE
 * MAXIMUM POST SPACING SHALL BE 3 m (10') C&C EXCEPT WHERE OTHERWISE SHOWN ON PLANS

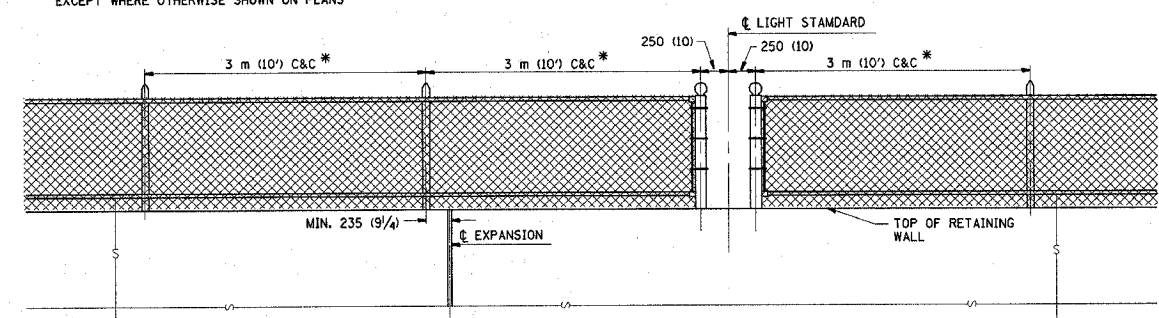

ELEVATION VIEW OF RETAINING WALL WITH PEDESTRIAN BARRIER TYPE III

FOR INFORMATIONAL PURPOSES ONLY

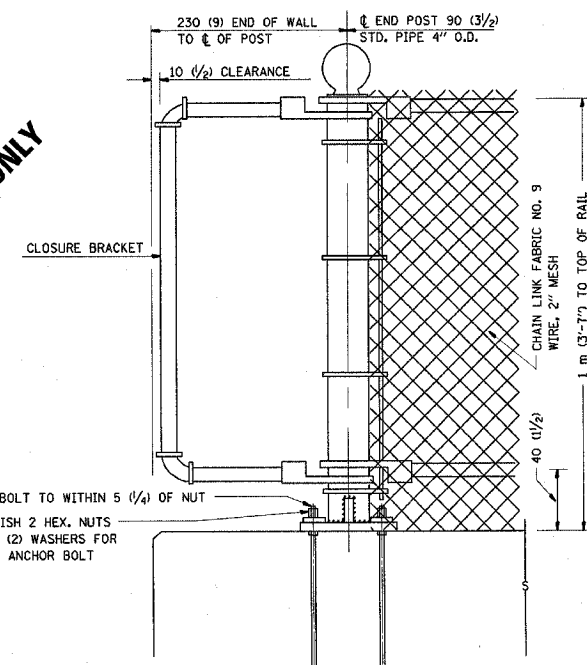

20 (3/4) Ø 360 (1'-2") ANCHOR BOLTS FURNISH 4 BOLTS EACH POST PLACE BOLTS IN FORM BEFORE POURING WALL CONCRETE.

END POST

NOTE:
 THE COST OF FURNISHING ANCHOR BOLTS, NUTS, & WASHERS TO BE INCIDENTAL

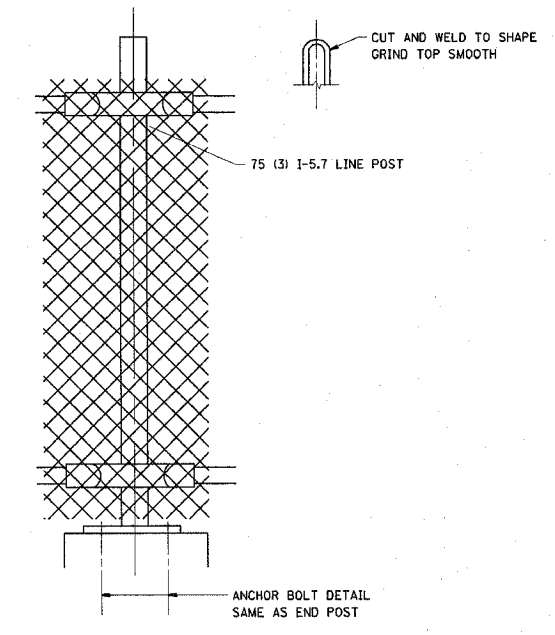

LINE POST

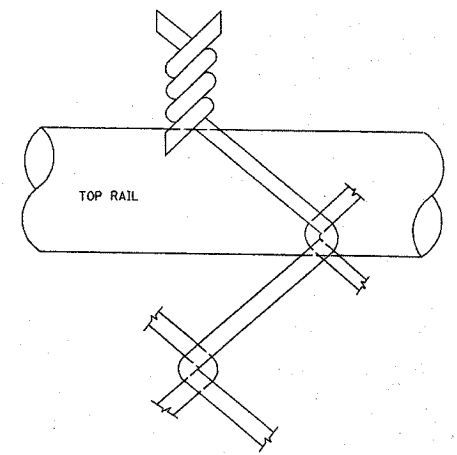

WIRE MESH FABRIC TO BE BARBED AT THE TOP

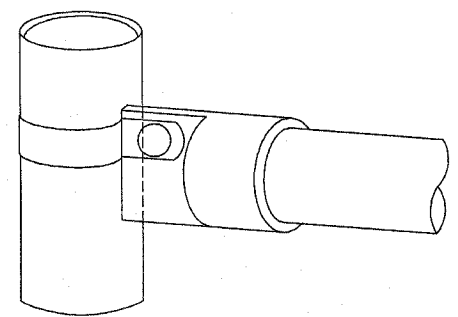

RAIL FITTING AT END POSTS

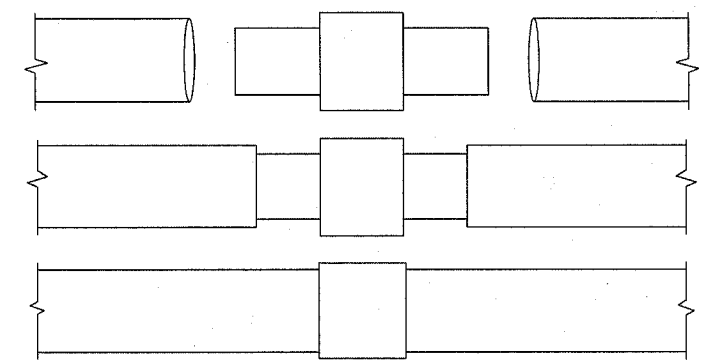

EXPANSION COUPLING DETAIL

NOTE:
 EXP. COUPLING TO APPEAR IN TOP AND BOTTOM RAILS WHERE EVER EXP. JT. APPEARS IN STRUCTURE.

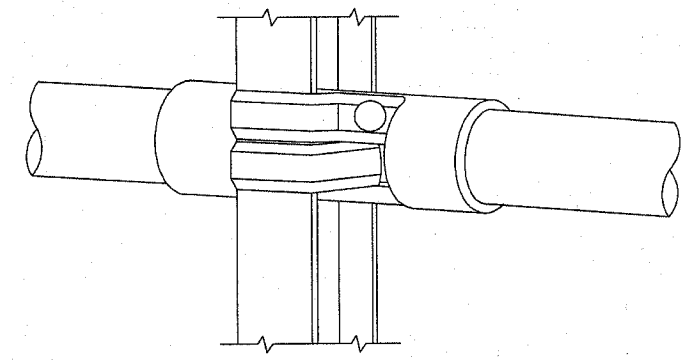

RAIL FITTING ON SECTION LINE POST

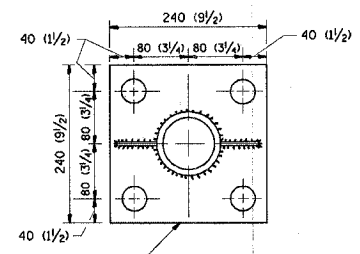

240 (9 1/2) X 80 (3 1/4) X 240 (9 1/2) BASE PLATE
 4-30 (1 1/4) Ø HOLES FOR END & LINE POSTS

ANCHOR PLATE DETAILS

NOTE:
 POST, PLATE AND GUSSET ASSEMBLY SHALL BE GALVANIZED AFTER ALL CUTTING, DRILLING, WELDING, AND FABRICATION HAVE BEEN COMPLETED. THE GALVANIZED COATING SHALL CONFORM TO THE REQUIREMENTS OF AASHTO M 120. THE GALVANIZED COATING SHALL NOT BE LESS THAN 610 G/50 M (2.0 OZ./50. FT.) OF SURFACE.

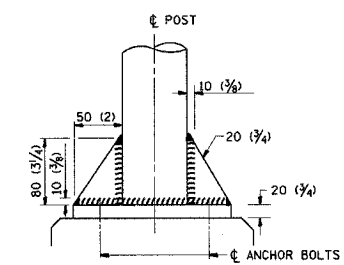

ALL DIMENSIONS ARE IN MILLIMETERS (INCHES) UNLESS OTHERWISE SHOWN.

ILLINOIS DEPARTMENT OF TRANSPORTATION
PEDESTRIAN BARRIER TYPE III
STD. 10-SS-514 R

SCALE: NONE
 DATE: 9/28/2006
 DRAWN BY: C.A.D.D.
 CHECKED BY:

REVISIONS	
NAME	DATE