

P.A. NO.	SECTION	COUNTY	TOTAL SHEETS	SHEET NO.
VAR. 2005-026 GRR	*		18	11
STA.	TO STA.			
FED. ROAD DIST. NO.	BLDG.	FED. AID PROJECT		

\* WILL, KANE, DU PAGE AND COOK  
**CONTRACT 62960**

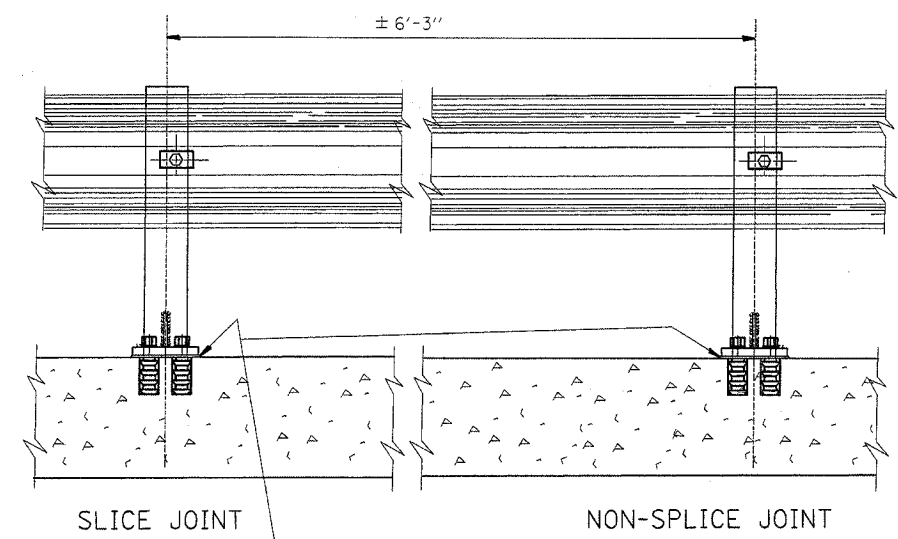

SEAL PERIMETER OF BASE OF POST TO MEDIAN WITH TWO COMPONENT NON-STAINING GRAY SEALING COMPOUND WITH POLYSULFIDE LIQUID POLYMERS - GUN GRADE WITH PRIMER

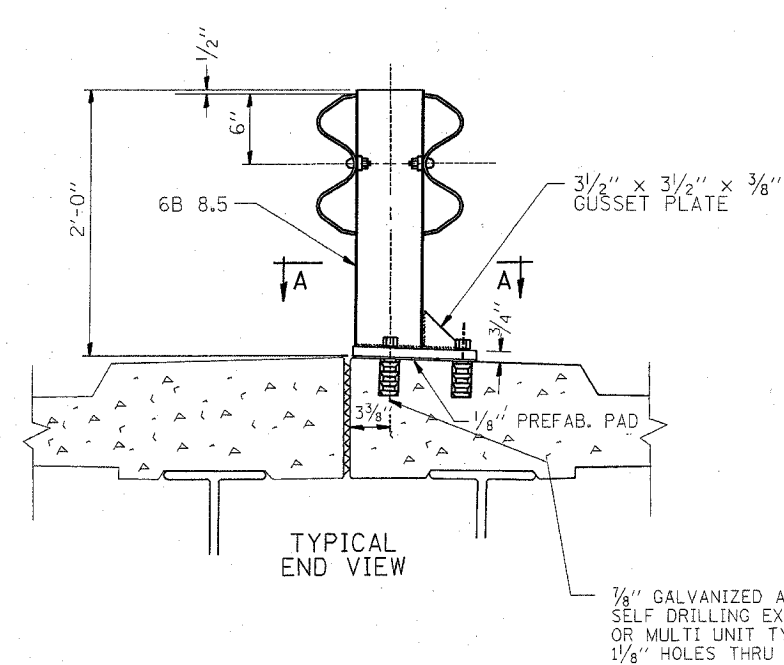
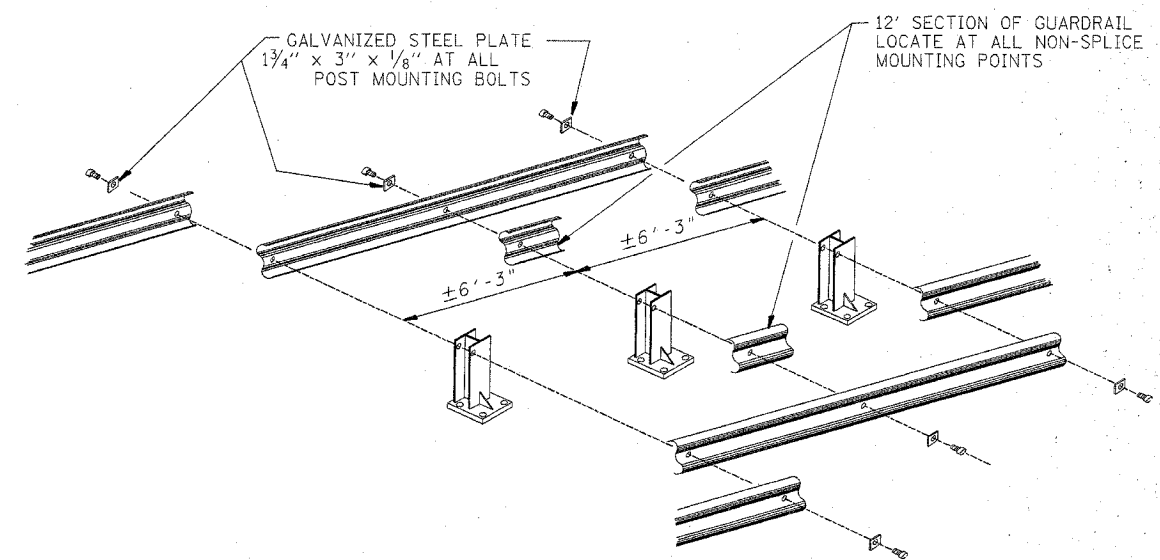

NOTE:  
 DIAMOND TIPPED DRILL SHALL BE USED TO DRILL THRU REINFORCEMENT BARS

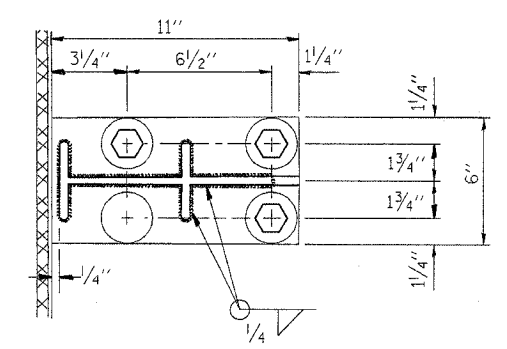

SEC. A-A

NOTE:  
 POSTS SHALL BE HOT DIPPED GALVANIZED AFTER FABRICATION IN ACCORDANCE WITH ASTM DESIGNATIONS A-123 AND A-385.  
 TWO PERCENT (2%) OF ALL ANCHOR BOLTS SHALL BE TEST LOADED IN PLACE. MIN. TEST LOAD = 8 KIPS.  
 ALL BOLTS, NUTS AND WASHERS SHALL BE GALVANIZED IN ACCORDANCE WITH ASTM DESIGNATION A-153.  
 FOR MATERIAL COMPOSITION OF PREFABRICATED PAD, SEE ARTICLE 54.9(F), (BEARING AND ANCHORAGE), OF THE STANDARD SPECIFICATIONS.  
 PROVIDE 1-1/8" AND 2-1/16" GALVANIZED STEEL SHIMS FOR 25% OF THE POSTS.  
 IF ONE ANCHOR BOLT FAILS DURING TEST, TWO OTHER ANCHOR BOLTS SHALL BE TESTED. TESTING EQUIPMENT CAN BE OBTAINED FROM BOLT COMPANIES.

REVISIONS	
NAME	DATE
CREATED	10-31-88

ILLINOIS DEPARTMENT OF TRANSPORTATION

**TYPICAL DETAIL FOR CENTER LONGITUDINAL JOINT GUARDRAIL JOINT**

SCALE: NONE  
 DATE: 10/2/2006

DRAWN BY: R.F.L.  
 CHECKED BY:

THIS SHEET IS FOR INFORMATION ONLY