

# GENERAL NOTES

ROUTE NO.	SEC.	COUNTY	TOTAL SHEETS	SHEET NO.
FAI 80 (I-80)	37-1HBR-1	Henry	133	4
FED ROAD DIST. NO.	ILLINOIS	PROJECT		
Contract #64602				

Bituminous and Aggregate Prime Coat shall be placed in accordance with Section 406 of the Standard Specifications. The cost of the prime coat shall be included in the contract unit price of the work for which it is required.

The new number for this structure will be 037-0171.

The contractor shall submit four copies of the required shop drawings for review and approval to the Bureau of Bridges and Structures, 2300 South Dirksen Parkway, Springfield, IL 62764. After approval of initial submittal, the contractor shall submit one set of shop drawings to Eric Harm, Engineer of Materials, 126 East Ash Street, Springfield, IL 62706, and eight (8) sets of shop drawings to be distributed to:

- District 2 District Engineer (1)
- Fabricator (1)
- Contractor (2)
- Resident Engineer (2)
- District 2 Bureau of Materials (2)

The additional thickness of proposed pavement required to match the bridge approach pavement, shown in Standard 420401, shall be included in the cost of the proposed pavement and not paid for separately.

The thickness for the Bridge Approach Pavement Connector (Flexible) adjacent to existing pavement shall be a minimum of 300 mm (12"). The material shall be 50 mm (2") Bituminous Concrete Surface Course Mixture D, and the remaining thickness shall be Bituminous Binder Course.

At bridge expansion joints, if temporary expansion joint bulkheads are attached to adjacent deck slabs or abutments for support, the Contractor shall cut the attachments as soon as the concrete has set to prevent joint damage due to horizontal contraction or expansion.

The curb is required on the bridge approach pavement as shown on Standard 420401.

Reflector Markers Type B shall be installed on the top of bridge parapet walls. The markers shall be according to Standard 635011 and the color and spacing according to Standard 635006, except the minimum is 2 per side.

The proposed pipes for entrances and side roads shall be placed in line with the existing or proposed ditch line.

It is anticipated that several mailboxes will require relocation to the approach side of the entrances. When this is done, the contractor shall be required to mount the mailbox on a 100 mm x 100 mm (4" x 4") wood post 1 m (40 inches) above the shoulder surface and extending to a minimum of 0.6 m (24 inches) into the embankment. This work shall be included in the contract unit price for the EARTH EXCAVATION. There are an estimated 3 mailboxes to be relocated.

Embankment quantities for the construction of the Traffic Barrier Terminals as shown in the plans are included in quantities for Furnished Excavation.

The Contractor shall supply the Resident Engineer with the manufacturer's installation requirements for the type of Steel Plate Beam Guardrail Terminal Type 1 Special (Tangent) or Steel Plate Beam Guardrail Terminal Type I Special (Flared).

One 16d galvanized nail shall be used to toe nail the wood block out to the wood post on all Traffic Barrier Terminal Type I Specials.

Delineators shall be installed as shown in Standard 635001, except that the post shall be rotated 180° and only metal-backed delineators shall be permitted.

Delineators shall be placed at the ends of approach guardrail terminal sections, and at each headwall or end section of AR Culverts. This work will be paid for at the contract unit price each for DELINEATORS.

Pavement Marking shall be done according to Standard 780001, except as follows:

1. All words, such as ONLY, shall be 2.4 m (8 feet) high.
2. All non-freeway arrows shall be the large size.
3. The distance between yellow no-passing lines shall be 200 mm (8"), not 180 mm (7") as shown in the detail of Typical Lane and Edge Lines.

PERMANENT SURVEY MARKERS, TYPE II, shall be set at intervals of 1.6 Km (1 mile) or as directed by the Engineer. Bridge or culvert projects shall have one survey marker placed near the structure. Estimated: 3 Each.

Permanent Survey Markers, Type II shall be cast-in-place as shown on District Standard 66.2.

The Resident Engineer shall determine the location of each Permanent Survey Marker Type II based on the project plans and modify locations as necessary. The Resident Engineer shall submit proposed locations to the Department's Chief of Survey a minimum of two weeks prior to Contractor installation for review and approval by the Department

The Contractor shall begin fence erection as soon as clearing operations permit. Before moving existing fence from an area that contains livestock, the Contractor shall erect, along the proposed right-of-way, a temporary fence or wire meeting the approval of the Engineer.

A contingency of 1,230 lineal feet of temporary fence has been included for those areas which might contain livestock. Temporary fence will be used as directed by the engineer.

All gutter outlets shall be extended to ditch flow as directed by the Engineer.

Right-of-way markers will be erected with the back face of the marker on the right-of-way line unless the new right-of-way line has been surveyed and pinned, in which instance the right-of-way markers will be set 300 mm (12 inches) inside the new right-of-way line.

The Contractor shall be responsible for protecting utility property during construction operations as outlined in Article 107.31 of the Standard Specifications. A minimum of 48 hours advance notice is required for non-emergency work. The JULIE number is 800-892-0123. The following listed utilities located within the project limits or immediately adjacent to the project construction limits are members of JULIE:

Geneseo Telephone  
Mediacom  
City of Colona

MidAmerican Energy Co.  
MCI World Com  
Geneseo Electric

Following are the known utilities located within the project limits or immediately adjacent to the project construction limits which are not members of JULIE and should be notified individually by the contractor:

Mr. Robert Delp  
Farmers Mutual Electric Co.  
PO Box 43  
1004 S. Chicago St.  
Geneseo, IL 61254-0043  
Ph. 309/944-4669

Mr. Kyle Lorenz  
IDOT - District 2  
819 Depot Ave.  
Dixon, IL 61021  
Ph. 815/284-5469

Program #5  
(Arch. Size)  
Enlarge  
200%  
Enlarge 107%

F.A.I. RTE.	SECTION	COUNTY	TOTAL SHEETS	SHEET NO.
80	37-1HBR-1	HENRY	133	9
STA. _____		TO STA. _____		
FED. ROAD DIST. NO. _____		ILLINOIS FED. AID PROJECT _____		

# TYPICAL SECTIONS

POPPY GARDEN RD  
STATION 35+90-44+50  
STATION 59+50-63+70

STRUCTURAL DESIGN INFORMATION - FLEXIBLE PAVEMENT  
STRUCTURAL DESIGN TRAFFIC: YEAR 2025  
PV = 2960 SU = 125 MU = 15

ROAD/STREET CLASSIFICATION: Class II

PERCENT OF STRUCTURAL DESIGN TRAFFIC IN DESIGN LANE:  
P = 50 S = 50 M = 50

TRAFFIC FACTOR: Actual TF = 0.202 Minimum TF = 0.5

AC Type = 20 AC Mixture Temp. = 78.6oF

AC Mixture Modulus = 585 Design Strain = 130

AC GRADE: Binder = PG 64-22 Surface = PG 64-22

Flexible Pavement Thickness = 8.5" Surface = 2" Binder = 6.5"

SUBGRADE SUPPORT RATING:

SSR = Poor (Sta. 35+90 to 63+70)

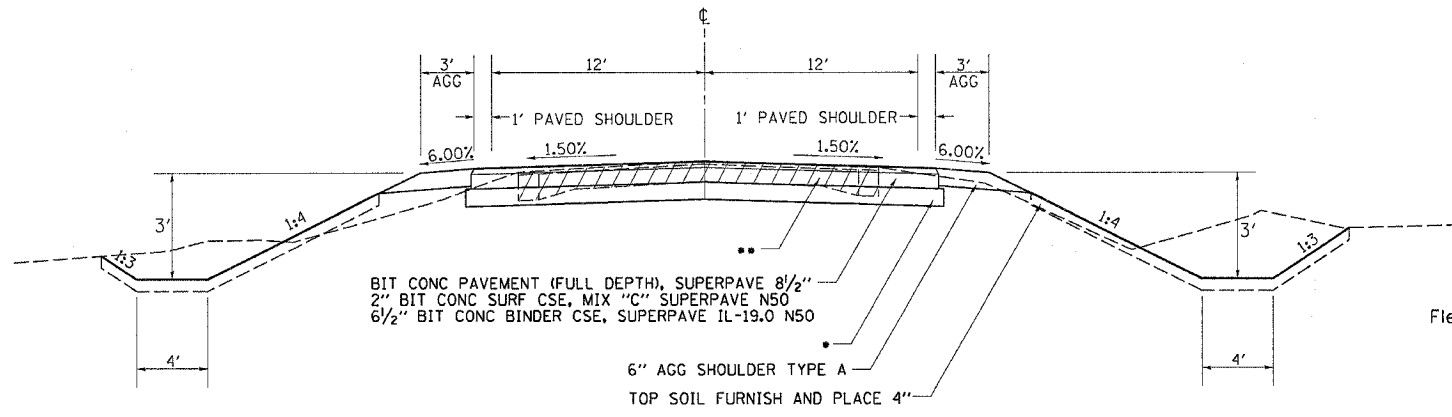

BRIDGE OMISSION 50+70.9 - 52+76.9

POPPY GARDEN RD  
STATION 44+50-45+50

NOTE:  
 • STATION 35+90-38+50 15" GRANULAR SUB-BASE MATERIAL TYPE "A" WITH GEOTECHNICAL FABRIC FOR GROUND STABILIZATION  
 • STATION 38+50-50+70.90 12" GRANULAR SUB-BASE MATERIAL TYPE "A"  
 • STATION 52+76.90-62+00 12" GRANULAR SUB-BASE MATERIAL TYPE "A"  
 • STATION 62+00-63+70 18" GRANULAR SUB-BASE MATERIAL TYPE "A" WITH GEOTECHNICAL FABRIC FOR GROUND STABILIZATION

NOTE:  
 PAVEMENT REMOVAL LIMITS  
 • STA 35+90 - STA 42+50  
 • STA 60+50 - STA 63+70  
 PAVEMENT BREAKING LIMITS  
 • STA 42+50 - STA 50+26  
 • STA 53+22 - STA 60+50  
 APPROACH SLAB REMOVAL  
 • STA 50+26 - STA 50+66  
 • STA 52+82 - STA 53+22

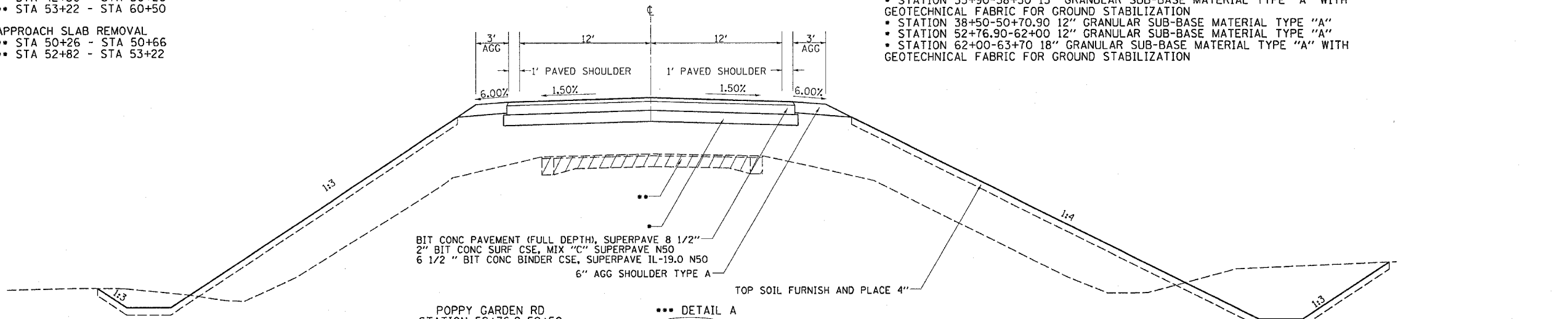

POPPY GARDEN RD  
STATION 52+76.9-59+50

\*\*\* DETAIL A

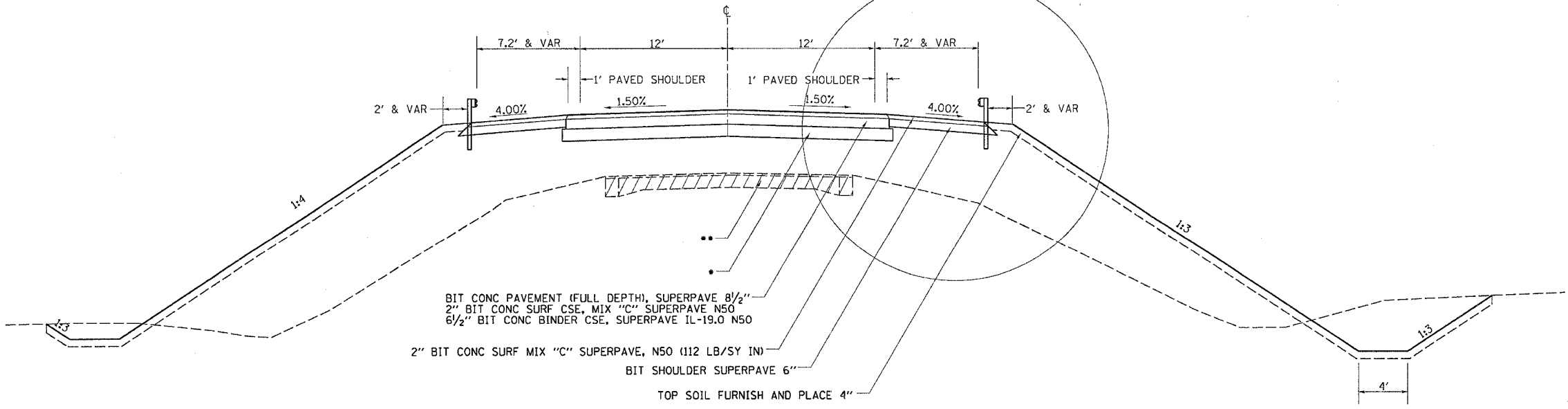

BIT CONC PAVEMENT (FULL DEPTH), SUPERPAVE 8 1/2"  
 2" BIT CONC SURF CSE, MIX "C" SUPERPAVE N50  
 6 1/2" BIT CONC BINDER CSE, SUPERPAVE IL-19.0 N50  
 2" BIT CONC SURF MIX "C" SUPERPAVE, N50 (112 LB/SY IN)  
 BIT SHOULDER SUPERPAVE 6"  
 TOP SOIL FURNISH AND PLACE 4"

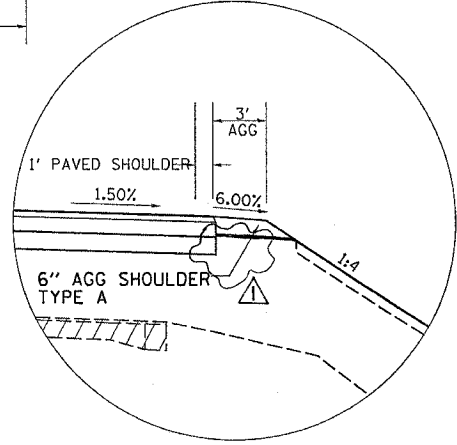

\*\*\* DETAIL A  
 STA 54+87.87 - STA 59+50 LT  
 STA 54+76.10 - STA 59+50 RT

**REVISED**  
 10-31-06

FILE NAME = #FILES  
 LEVELS = #LEVELS  
 PLOT SCALE = #PLOTS  
 PLOT DATE = FRI Sep 01 10:17:05 2006  
 PRINT DATE = FRI Sep 01 10:17:05 2006  
 REFERENCE = 49-0999 / IN  
 REFERENCE = #REF

F.A.I. RTE.	SECTION	COUNTY	TOTAL SHEETS	SHEET NO.
37	IHRB-J	HENRY	133	10
STA. _____ TO STA. _____		FED. ROAD DIST. NO. ILLINOIS FED. AID PROJECT		

# TYPICAL SECTIONS

- NOTE:  
 PAVEMENT REMOVAL LIMITS  
 •• STA 35+90 - STA 42+50  
 •• STA 60+50 - STA 63+70
- PAVEMENT BREAKING LIMITS  
 •• STA 42+50 - STA 50+26  
 •• STA 53+22 - STA 60+50
- APPROACH SLAB REMOVAL  
 •• STA 50+26 - STA 50+66  
 •• STA 52+82 - STA 53+22

• STA 45+50 - 46+00  
 LT FORESLOPE TRANSITIONS FROM 1:3 TO 1:2

POPPY GARDEN RD  
 STATION 45+50-50+70.9

..... DETAIL

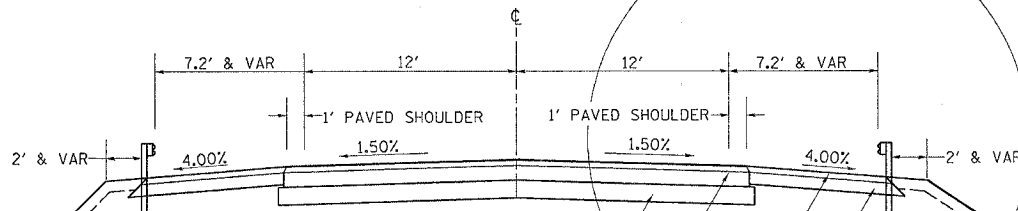

..... GUARDRAIL ON RT  
 STA 48+51.55 - STA 50+70.9

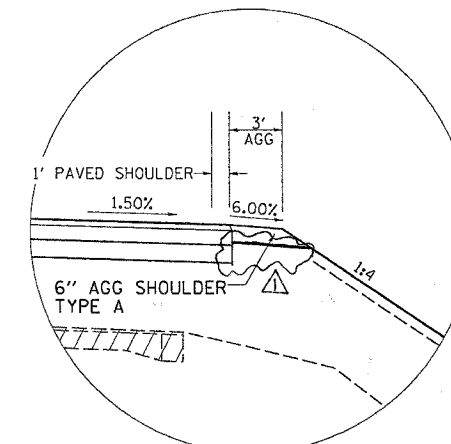

..... DETAIL  
 STA 45+50 - STA 48+59.36 RT

12" GRANULAR SUB-BASE MATERIAL TYPE A  
 BIT CONC PAVEMENT (FULL DEPTH), SUPERPAVE 8 1/2"  
 2" BIT CONC SURF CSE, MIX "C" SUPERPAVE N50  
 6 1/2" BIT CONC BINDER CSE, SUPERPAVE IL-19.0 N50  
 2" BIT CONC SURF MIX "C" SUPERPAVE, N50 (112 LB/SY IN)  
 BIT SHOULDER SUPERPAVE 6"

TOP SOIL FURNISH AND PLACE 4"

..... DETAIL A  
 STA 100+13 - STA 100+63.63 LT  
 STA 100+13 - STA 100+62.38 RT

CARROLL ST

..... DETAIL

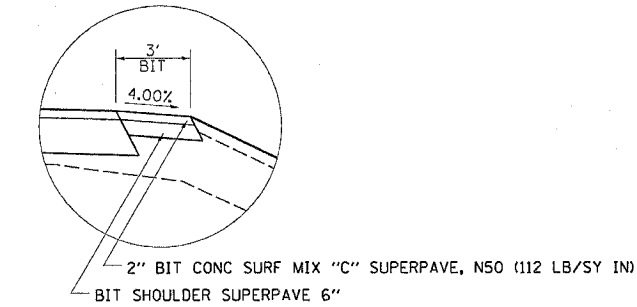
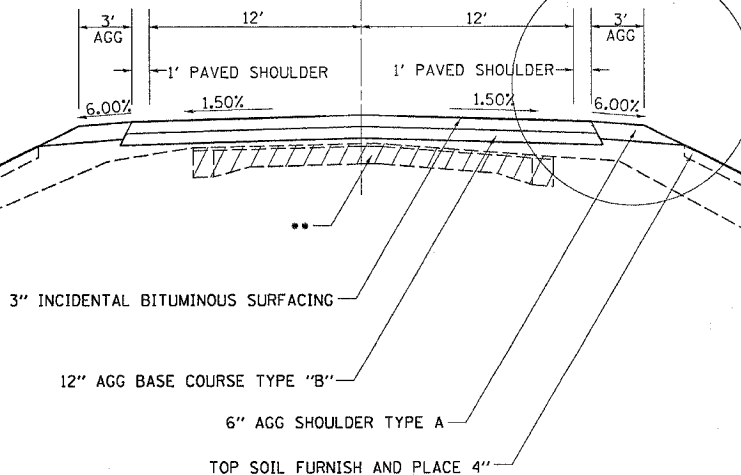

3" INCIDENTAL BITUMINOUS SURFACING  
 12" AGG BASE COURSE TYPE "B"  
 6" AGG SHOULDER TYPE A  
 TOP SOIL FURNISH AND PLACE 4"

STRUCTURAL DESIGN INFORMATION - FLEXIBLE PAVEMENT  
 STRUCTURAL DESIGN TRAFFIC: YEAR 2025  
 PV = 2960 SU = 125 MU = 15

ROAD/STREET CLASSIFICATION: Class II

PERCENT OF STRUCTURAL DESIGN TRAFFIC IN DESIGN LANE:  
 P = 50 S = 50 M = 50

TRAFFIC FACTOR: Actual TF = 0.202 Minimum TF = 0.5

AC Type = 20 AC Mixture Temp. = 78.6oF  
 AC Mixture Modulus = 585 Design Strain = 130  
 AC GRADE: Binder = PG 64-22 Surface = PG 64-22  
 Flexible Pavement Thickness = 8.5" Surface = 2" Binder = 6.5"  
 SUBGRADE SUPPORT RATING:  
 SSR = Poor (Sta. 35+90 to 63+70)

REVIS  
 10-31-06

FILE NAME = #FILES#  
 LEVELS = #LEVELS#  
 PLOT SCALE = #PLOTS/SCALE#  
 OPERATOR = Mon Oct 02 09:31:55 2006  
 OPERATOR = Mon Oct 02 09:31:55 2006  
 PLOT DATE = Mon Oct 02 09:31:55 2006  
 PLOT TIME = 10:07:00 AM  
 PLOT NAME = c:\pwork\10211108\10211108typ.dgn  
 PLOT SIZE = 11.00 x 17.00  
 PLOT REFERENCE = AREF#