

STATE OF ILLINOIS
DEPARTMENT OF TRANSPORTATION

ROUTE NO.	SECTION	COUNT	TOTAL SHEETS	SHEET NO.	SHEET NO. 18 36 SHEETS
F.A.P. 315	34-6, 55-1	HANCOCK	433	216	
FED. ROAD DIST. NO. 7	ILLINOIS	FED. AID PROJECT			

Contract #68206

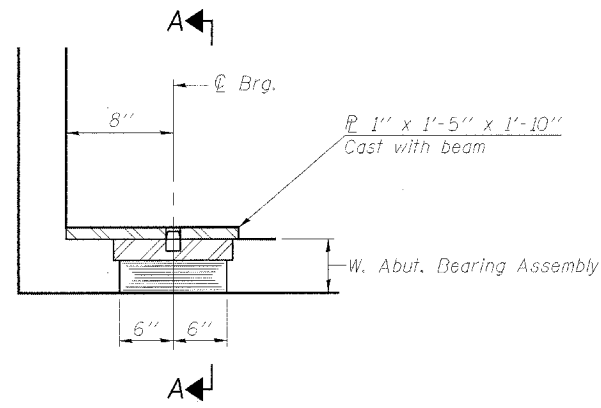

SECTION AT W. ABUT.

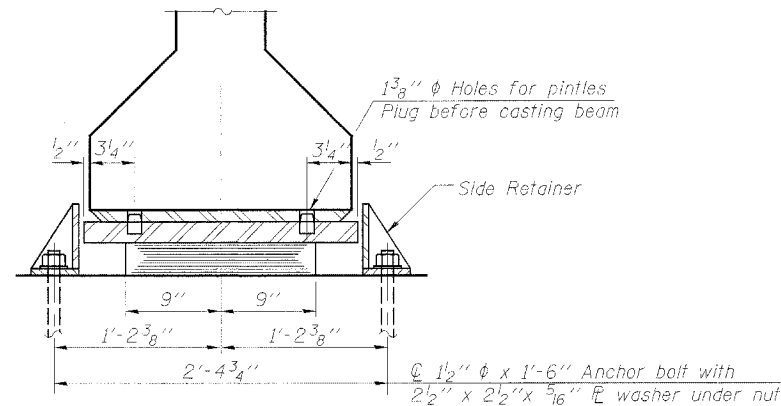

SECTION A-A

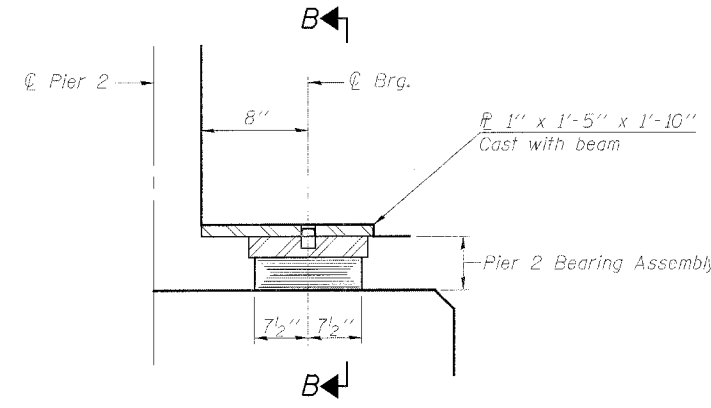

SECTION AT PIER 2

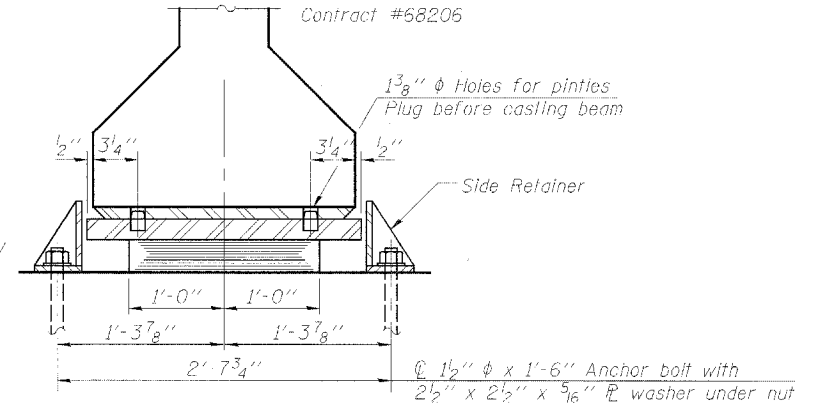

SECTION B-B

TYPE I ELASTOMERIC EXP. BRG.

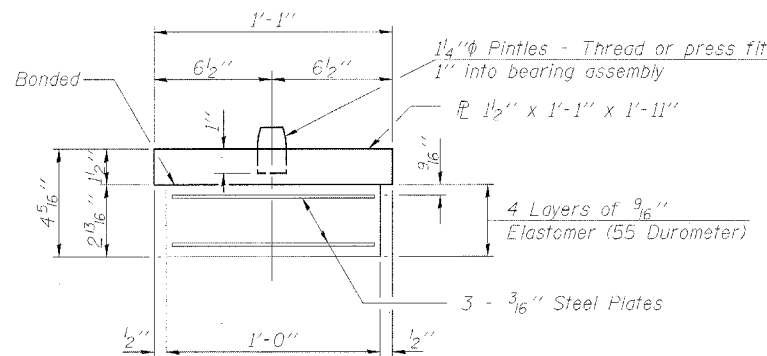

W. ABUT. BEARING ASSEMBLY



PINTLE

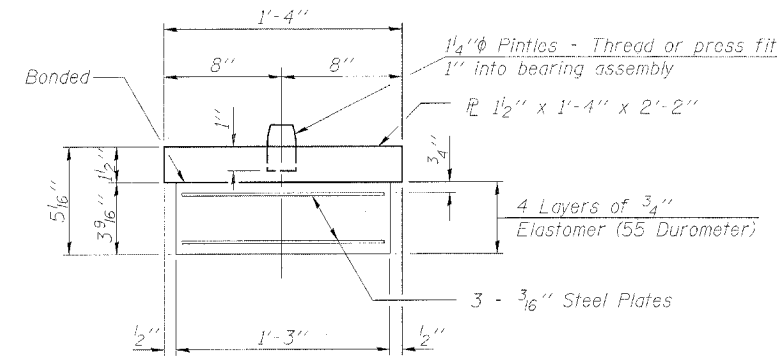

PIER 2 BEARING ASSEMBLY

Notes:
Holes at expansion bearings shall be drilled and anchor bolts grouted in place after beams have been erected.
See sheet 20 of 36 for anchor bolt installation.
See sheet 17 of 36 for additional details of plate cast with beam.

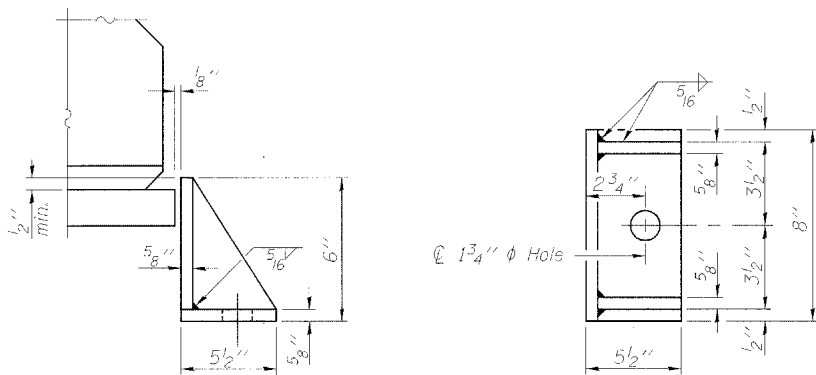

SIDE RETAINER

Cost included with Elastomeric Bearing Assembly, Type I.
Equivalent rolled angle with stiffeners will be allowed in lieu of welded plates.

DESIGNED	KLH
CHECKED	EML
DRAWN	KBF/EML
CHECKED	KPH

HORNER & SHIFRIN, INC.
ENGINEERS ■ ARCHITECTS ■ PLANNERS

BILL OF MATERIAL (W. ABUT.)
(ONE STRUCTURE)

Item	Unit	Total
Elastomeric Bearing Assembly, Type I	Each	6

BILL OF MATERIAL (PIER 2)
(ONE STRUCTURE)

Item	Unit	Total
Elastomeric Bearing Assembly, Type I	Each	12

BEARING DETAILS, TYPE I
ILLINOIS ROUTE 336 OVER
EAST FORK OF THE LAMOINE RIVER
F.A.P. ROUTE 315 - SECTION 34-6, 55-1
HANCOCK COUNTY; STA. 1432+02.61
STRUCTURE NO. 034-0511 (E.B.)
STRUCTURE NO. 034-0512 (W.B.)