

FAP ROUTE	SECTION	COUNTY	TOTAL SHEETS	SHEET NO.
42	2BR	WASHINGTON	33	4
STA.		TO STA.		

EXISTING CONDITIONS:
CONTRACT NO. 76389

DATE	BY	REVISION

PLAN
 NO. _____

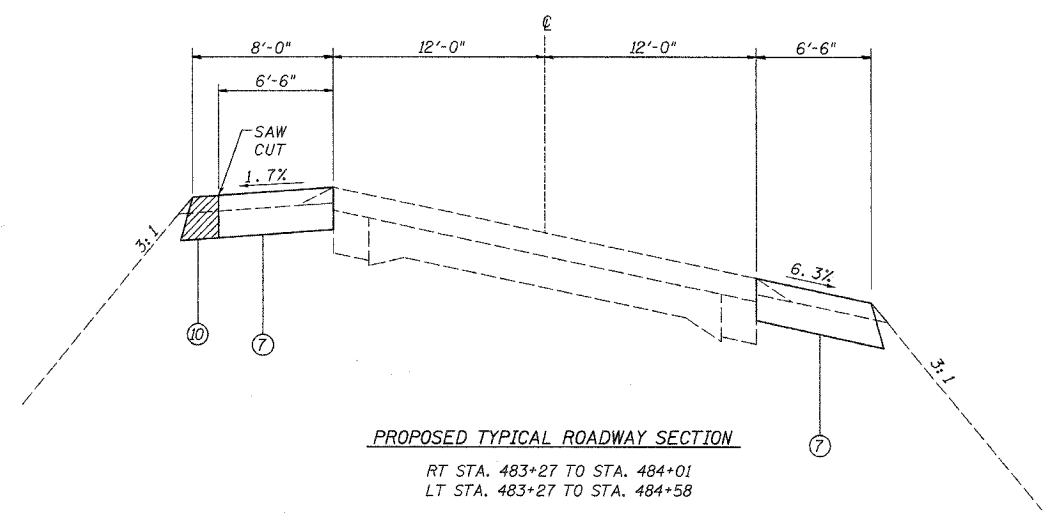

PROPOSED TYPICAL ROADWAY SECTION
 RT STA. 483+27 TO STA. 484+01
 LT STA. 483+27 TO STA. 484+58

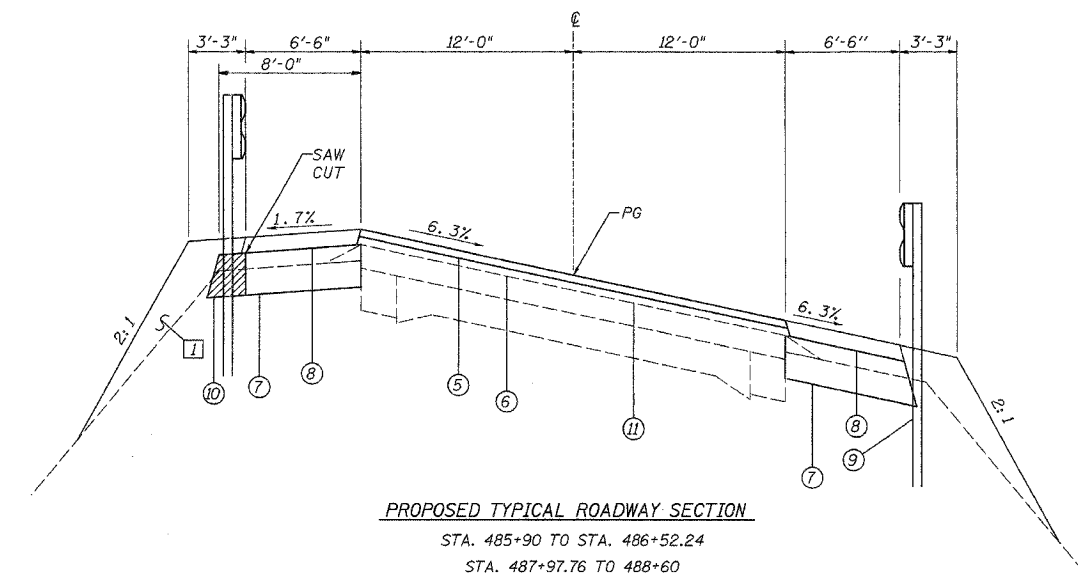

PROPOSED TYPICAL ROADWAY SECTION
 STA. 485+90 TO STA. 486+52.24
 STA. 487+97.76 TO 488+60

LEGEND

- 1 EXISTING CONCRETE PAVEMENT (9'-6"-9')
- 2 EXISTING CONCRETE WIDENING 8"
- 3 EXISTING BITUMINOUS CONCRETE 4 1/2"
- 4 EXISTING AGGREGATE SHOULDERS
- 5 PROPOSED BITUMINOUS CONCRETE SURFACE COURSE, SUPERPAVE, MIX "C", N70 1 1/2"
- 6 PROPOSED BITUMINOUS CONCRETE BINDER COURSE, SUPERPAVE, IL 19.0, N70 1 1/2"
- 7 PROPOSED BITUMINOUS BASE COURSE SUPERPAVE 8"
- 8 PROPOSED BITUMINOUS SHOULDERS, SUPERPAVE
- 9 PROPOSED STEEL PLATE BEAM GUARD RAIL TYPE A
- 10 PROPOSED PAVEMENT REMOVAL
- 11 BITUMINOUS MATERIALS (PRIME COAT)
- [] EMBANKMENT TO BE CONSTRUCTED IN PRELIMINARY PHASE

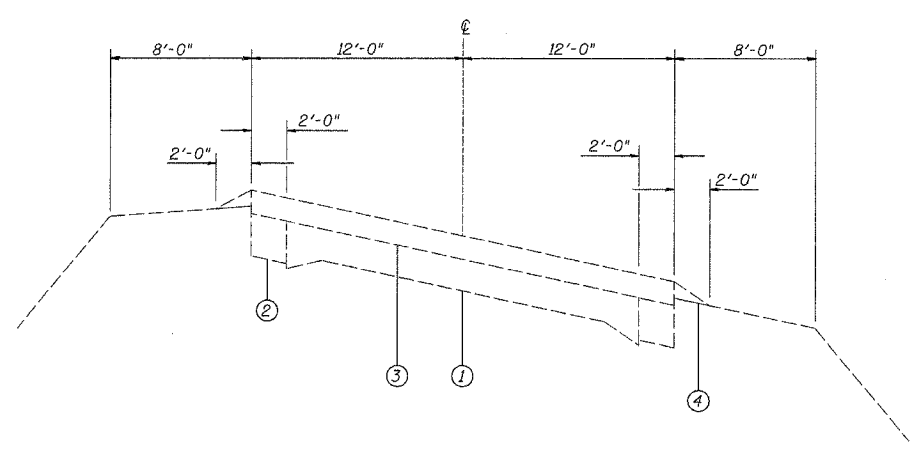

EXISTING TYPICAL ROADWAY SECTION
 STA. 483+27 TO STA. 486+97.7
 STA. 487+49.3 TO STA. 488+95.06

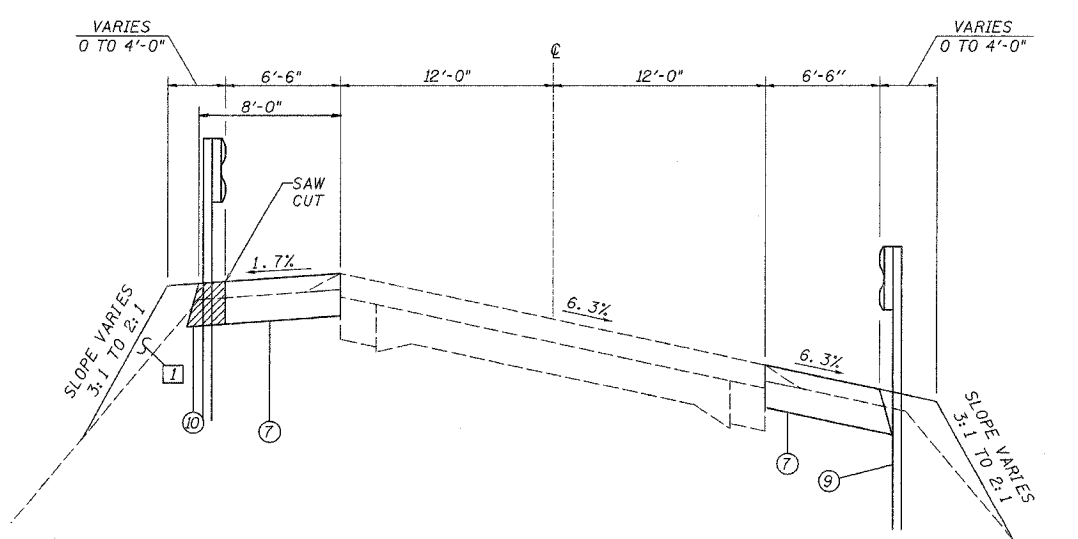

PROPOSED TYPICAL ROADWAY SECTION
 RT STA. 484+01 TO STA. 485+90
 LT STA. 484+58 TO STA. 485+90
 STA. 488+60 TO STA. 488+95.06

OMISSIONS:
 BRIDGE APPROACH PAVEMENT:
 @ STA 486+52.24 TO STA 486+82.24
 @ STA 487+67.76 TO STA 487+97.76
 BRIDGE:
 @ STA 486+82.24 TO STA 487+67.76

TYPICAL CROSS SECTIONS

FAP ROUTE 42 (IL 127)
 SECTION 2BR
 WASHINGTON COUNTY

CUMMINS ENGINEERING CORPORATION	JOB #: 2158
	FILE: 2158 typical
	DATE: 6/22/05

DATE-TIME
 DATE-TIME
 DATE-TIME
 DATE-TIME