

| F.A.U. RTE.         | SECTION | COUNTY      | TOTAL SHEETS     | SHEET NO. |
|---------------------|---------|-------------|------------------|-----------|
| 1441 DO-00059-00-BR |         | KANE        | 154              | 36        |
| STA. N/A            |         | TO STA. N/A |                  |           |
| FED. ROAD DIST. NO. |         | ILLINOIS    | FED. AID PROJECT |           |

| F.A. REC.             | SECTION | COUNTY   | TOTAL SHEETS     | SHEET NO. |
|-----------------------|---------|----------|------------------|-----------|
|                       |         |          |                  |           |
| STA.                  |         | TO STA.  |                  |           |
| FED. ROAD DIST. NO. 1 |         | ILLINOIS | FED. AID PROJECT |           |

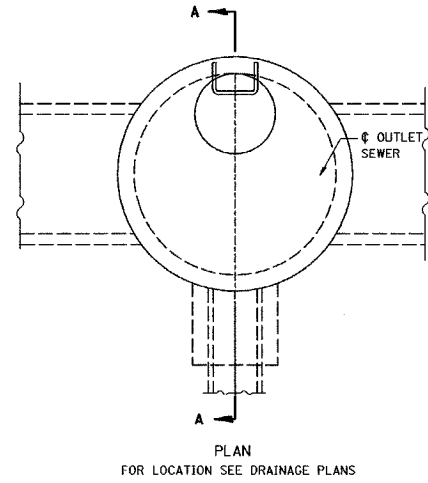

| ENCASEMENT DETAILS                       |  |
|--|--|
| DROP M.H. LOCATION STA., OFFSET          |  |
| INV. "A"                                 |  |
| INLET PIPE                               |  |
| INV. "B"                                 |  |
| INV. "C"                                 |  |
| A  |  |
| B  |  |
| "V" BAR LENGTH                           |  |
| NO. OF "U" BARS                          |  |
| REINF. BARS                              |  |
| CLASS "SI" CONC. (CUBIC METER (CIL YD.)) |  |

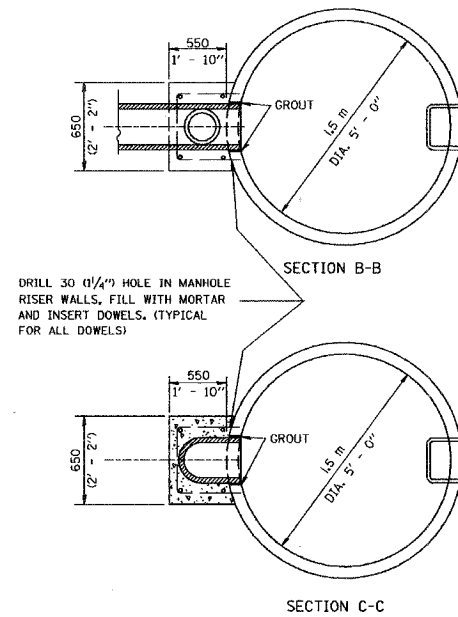
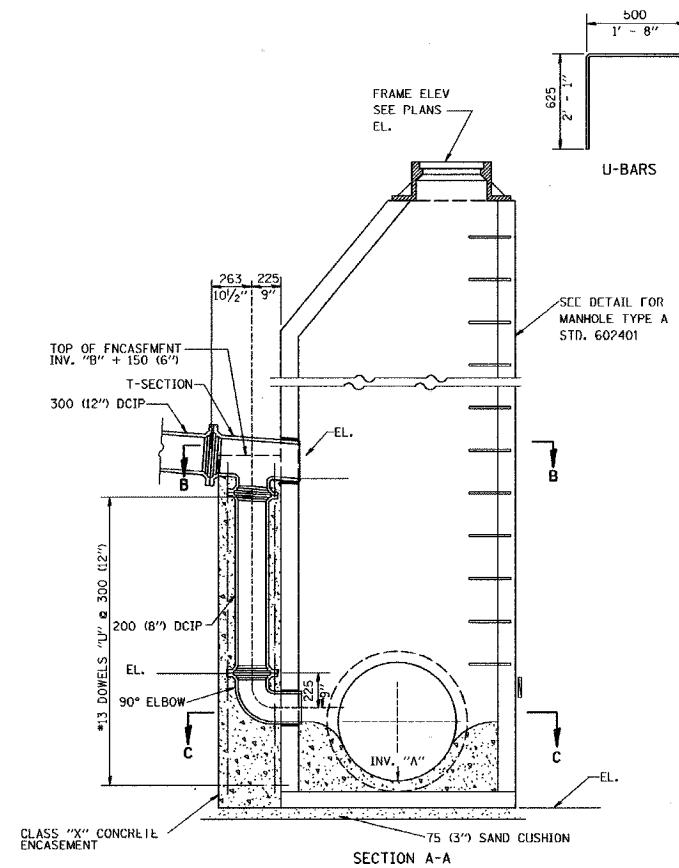

ALL DIMENSIONS ARE IN MILLIMETERS (INCHES) UNLESS OTHERWISE SHOWN

ILLINOIS DEPARTMENT OF TRANSPORTATION

DROP MANHOLE DETAILS

| REVISIONS |      |
|-----------|------|
| NAME      | DATE |
|           |      |
|           |      |
|           |      |
|           |      |
|           |      |

SCALE: NONE  
DATE 10/18/2002

DRAWN BY jls  
CHECKED BY [Signature]

- TYPE A1-1 MANHOLE WITH 1 DROP AND DEPTH UP TO 3 m (10')
- TYPE A1-2 " " " " FROM 3 m TO 1.5 m (10' TO 15')
- TYPE A1-3 " " " " FROM 1.5 m TO 6 m (15' TO 20')
- TYPE A1-4 " " " " OVER 6 m (20')
- TYPE A2-1 MANHOLE WITH 2 DROPS AND DEPTH UP TO 3 m (10')
- TYPE A2-2 " " " " FROM 3 m TO 1.5 m (10' TO 15')
- TYPE A2-3 " " " " FROM 1.5 m TO 6 m (15' TO 20')
- TYPE A2-4 " " " " OVER 6 m (20')

| REVISIONS |      |
|-----------|------|
| NAME      | DATE |
|           |      |
|           |      |
|           |      |
|           |      |
|           |      |

ILLINOIS DEPARTMENT OF TRANSPORTATION  
WILSON STREET  
DROP MANHOLE DETAILS

SCALE: NPS30  
DATE 07/28/2006

DRAWN BY AWM  
CHECKED BY AKK