

FAP. NO.	CONTRACT NO.	COUNTY	TOTAL SHEETS	SHEET NO.
348	83871	COOK	4	2
STA.	TO STA.			
FED. ROAD DIST. NO.	ILLINOIS	FED. AID PROJECT		

S.I. CODE NO.	PAY ITEM	UNIT	QUAN	SIDEWALKS	MARKINGS	LANDSCAPE
				CONSTRUCTION TYPE CODE		
				SFTY-1B	SFTY-1D	Y003
20200410	EARTH EXCAVATION (SPECIAL)	CU YD	2508	2508		
21101615	TOPSOIL FURNISH AND PLACE, 4"	SQ YD	1000			1000
25000210	SEEDING, CLASS 2A	ACRE	0.02			0.02
25000400	NITROGEN FERTILIZER NUTRIENT	POUND	2			2
25000500	PHOSPHORUS FERTILIZER NUTRIENT	POUND	2			2
25000600	POTASSIUM FERTILIZER NUTRIENT	POUND	2			2
25100630	EROSION CONTROL BLANKET	SQ YD	968			968
28000400	PERIMETER EROSION BARRIER	FOOT	1489	1489		
31101200	SUB-BASE GRANULAR MATERIAL, TYPE B 4"	SQ YD	836	836		
42001300	PROTECTIVE COAT	SQ YD	836	836		
42400200	PORTLAND CEMENT CONCRETE SIDEWALK 5 INCH	SQ FT	7525	7525		
42400800	DETECTABLE WARNINGS	SQ FT	48	48		
60300305	FRAMES AND LIDS TO BE ADJUSTED	EACH	2	2		
60605000	COMBINATION CONCRETE CURB AND GUTTER, TYPE B-6.24	FOOT	30	30		
67100100	MOBILIZATION	L SUM	1	1		
70101700	TRAFFIC CONTROL AND PROTECTION	L SUM	1	1		
* 78000400	THERMOPLASTIC PAVEMENT MARKING - LINE 6"	FOOT	90		90	

* - INDICATES SPECIALTY ITEMS

GENERAL NOTES

- ANY REFERENCE TO STANDARDS THROUGHOUT THE PLANS OR SPECIAL PROVISIONS SHALL BE INTERPRETED TO BE THE LATEST STANDARDS OF THE ILLINOIS DEPARTMENT OF TRANSPORTATION.
- ITEMS OF WORK LISTED IN THE SUMMARY OF QUANTITIES WHICH ARE NOT SPECIFICALLY INDICATED IN THE PLANS SHALL BE PERFORMED AT LOCATIONS AS DIRECTED BY THE ENGINEER.
- WHEN, IN THE CONSTRUCTION OPERATION, ANY LOOSE MATERIAL IS DEPOSITED IN THE FLOW LINE OF DITCHES, GUTTERS OR OTHER DRAINAGE STRUCTURES SO THAT THE NATURAL FLOW OF WATER IS OBSTRUCTED, IT SHALL BE REMOVED AT THE CLOSE OF EACH DAY BY THE CONTRACTOR AT HIS EXPENSE. AT THE CONCLUSION OF THE CONSTRUCTION OPERATIONS, ALL DRAINAGE STRUCTURES SHALL BE FREE FROM ALL DIRT AND DEBRIS. THIS WORK SHALL NOT BE PAID FOR SEPARATELY BUT SHALL BE CONSIDERED INCIDENTAL TO THE CONTRACT.
- THE APPROXIMATE LOCATION OF KNOWN PUBLIC UTILITIES ARE SHOWN ON THE PLANS. HOWEVER, THE DEPARTMENT DOES NOT GUARANTEE ITS ACCURACY. PRIOR TO COMMENCING OPERATIONS ON THE PROJECT WHICH MAY IN ANY WAY CREATE THE POSSIBILITY OF INVOLVEMENT WITH EXISTING UTILITIES, THE CONTRACTOR SHALL CONTACT THE UTILITY COMPANY INVOLVED. ADJUSTMENT OF ALL PUBLIC UTILITIES WITHIN THE LIMITS OF THIS IMPROVEMENT WILL BE DONE BY THE RESPECTIVE OWNERS. NO ADDITIONAL COMPENSATION WILL BE ALLOWED DUE TO DELAYS OR INCONVENIENCE CAUSED BY THESE ADJUSTMENTS. IT SHALL BE THE CONTRACTOR'S RESPONSIBILITY TO VERIFY LOCATIONS OF UNDERGROUND INSTALLATION BEFORE STARTING CONSTRUCTION OPERATIONS. PLANS FOR THESE ADJUSTMENTS WILL BE ON FILE IN THE OFFICE OF THE COOK COUNTY HIGHWAY DEPARTMENT, BUREAU OF CONSTRUCTION FOR INFORMATION AND USE.
- BEFORE STARTING ANY EXCAVATION, THE CONTRACTOR SHALL CALL "JULIE" AT 800-892-0123 FOR FIELD LOCATIONS OF BURIED ELECTRIC, TELEPHONE AND GAS FACILITIES. (48 HOURS NOTIFICATION IS REQUIRED).
- THE CONTRACTOR SHALL COORDINATE CONSTRUCTION ACTIVITIES WITH UTILITY COMPANIES.
- THE CONTRACTOR SHALL CONTACT THE DISTRICT ONE TRAFFIC CONTROL SUPERVISOR AT (847) 705-4150 A MINIMUM OF 5 WORKING DAYS IN ADVANCE OF BEGINNING WORK. THE CONTRACTOR SHALL ALSO CONTACT ROBINSON ENGINEERING (708) 331-6700, AND THE VILLAGE OF WORTH (708) 448-4256 A MINIMUM OF 72 HOURS IN ADVANCE OF BEGINNING WORK.
- ALL PAVEMENT, CURB AND SIDEWALK REMOVALS SHALL BE MADE BY MEANS OF STRAIGHT SAW CUT JOINT. THE COST FOR SAW CUTTING SHALL BE INCIDENTAL TO THE CONTRACT.
- CONTRACTOR SHALL BE RESPONSIBLE AT ALL TIMES FOR TRAFFIC CONTROL AND PROTECTION IN ACCORDANCE WITH THE IDOT STANDARD SPECIFICATIONS ADOPTED JANUARY 1, 2002, THE LATEST EDITION OF THE ILLINOIS MANUAL ON UNIFORM TRAFFIC CONTROL DEVICES FOR STREETS AND HIGHWAYS, AND THE STANDARD SPECIFICATIONS FOR TRAFFIC CONTROL ITEMS.

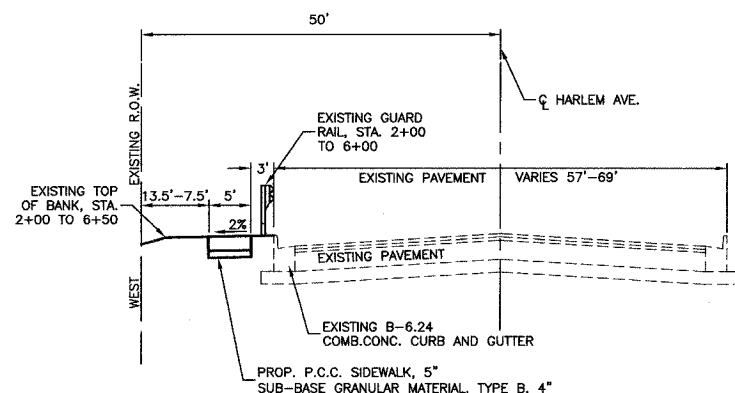

TYPICAL CROSS SECTION
STA. 2+13.64 TO STA. 17+75

NOTE: RESTORATION SHALL BE LIMITED TO 2' ON EITHER SIDE OF THE SIDEWALK UNLESS OTHERWISE APPROVED BY THE ENGINEER.

EARTHWORK QUANTITIES

TOTAL CUT - 2508 CY
TOTAL FILL - 10 CY
CUT TO FILL - 10 CY

ROBINSON ENGINEERING, LTD. CONSULTING REGISTERED PROFESSIONAL ENGINEERS AND PROFESSIONAL LAND SURVEYORS 17000 SOUTH PARK AVENUE SOUTH HOLLAND, ILLINOIS 60473 (708) 331-6700 FAX (708) 331-3828 © COPYRIGHT 2001 ILLINOIS DESIGN FIRM REGISTRATION NO. 184001128		REVISIONS No. Date Remarks	
SUMMARY OF QUANTITIES & GENERAL NOTES & TYPICAL SECTION HARLEM AVENUE SIDEWALK CONSTRUCTION SECTION NO. 04-0050-00-SW WORTH, ILLINOIS			
Drawn by: LTL	Date:	Checked by: PKB/WPD	Scale: NONE
Sheet 002 of 004	Project No. 04-625		