

RTE NO.	SECTION	COUNTY	TOTAL	SHEET #
FA 646	(Y)W-1, RS-3	PEORIA	142	13

LEGEND - EXISTING

- ① P.C.C. PAVEMENT
- ② P.C.C. WIDENING
- ③ FLEXIBLE PAVEMENT
- ④ BITUMINOUS OVERLAY (VARIABLE DEPTH)

REMOVAL

- ⑧ PAVEMENT REMOVAL (FLEXIBLE)
- ⑨ PAVED SHOULDER REMOVAL
- ⑩ BITUMINOUS SHOULDER REMOVAL (VARIABLE DEPTH, 150 mm OR 225 mm)
- ⑪ SOLID MEDIAN REMOVAL
- ⑫ COMBINATION CURB & GUTTER REMOVAL
- ⑬ BITUMINOUS SURFACE REMOVAL (VARIABLE DEPTH)

LEGEND - PROPOSED

SHOULDERS

- ⑳ AGGREGATE SHOULDERS, TYPE B, 150 mm
- ㉑ AGGREGATE SHOULDERS, TYPE B, (METRIC TON)
- ㉒ BITUMINOUS SHOULDERS, SUPERPAVE, 200 mm
- ㉓ BITUMINOUS SHOULDERS, SUPERPAVE, (METRIC TON)
- ㉔ BITUMINOUS SHOULDERS, SUPERPAVE, 150 mm

BASE COURSE

- ㉕ BITUMINOUS BASE COURSE, SUPERPAVE, 200 mm
- ㉖ BITUMINOUS BASE COURSE, SUPERPAVE, 250 mm
- ㉗ BITUMINOUS BASE COURSE, SUPERPAVE, (METRIC TON)
- ㉘ BITUMINOUS BASE COURSE WIDENING, SUPERPAVE, 250 mm
- ㉙ BITUMINOUS BASE COURSE WIDENING, SUPERPAVE, 200 mm

BINDER COURSE & LEVELING BINDER COURSE

- ㉚ BITUMINOUS CONCRETE BINDER COURSE SUPERPAVE, IL-19.0, N70, 38 mm
- ㉛ BITUMINOUS CONCRETE BINDER COURSE SUPERPAVE, IL-19.0, N70, 51 mm
- ㉜ LEVELING BINDER (MACHINE METHOD) SUPERPAVE, N70 - VARIABLE THICKNESS

SURFACE COURSE

- ㉝ BITUMINOUS CONCRETE SURFACE COURSE SUPERPAVE, MIXTURE "D", N70, 38 mm
- ㉞ BITUMINOUS CONCRETE SURFACE COURSE SUPERPAVE, MIXTURE "D", N70, 51 mm

FULL DEPTH PAVEMENT

- ㉟ BIT CONC PAVEMENT (FULL-DEPTH), SUPERPAVE, 300 mm
- ㊱ BIT CONC PAVEMENT (FULL-DEPTH), SUPERPAVE, 290 mm

MISC & STANDARDS

- ㊲ TOPSOIL (100 mm)
- ㊳ SUBBASE GRANULAR MATERIAL, TYPE A
- ㊴ COMBINATION CONC C&G, TYPE B-15.60
- ㊵ PIPE UNDERDRAINS, 100 mm
- ㊶ REFER TO STANDARD 482001 (TYPE C SUBBASE)
- ㊷ GRANULAR EMBANKMENT, SPECIAL
- ㊸ STRIP REFLECTIVE CRACK CONTROL

VERTICAL & HORIZONTAL CONTROL

- ㊹ CONTROL GRADE
- ㊺ EDGE OF NORTH BOUND LANES
- ㊻ EDGE OF PAVEMENT, RELOCATED IL RTE 40

NOTE:

THE FINAL LIFT OF BITUMINOUS CONCRETE PAVEMENT (FULL DEPTH), SUPERPAVE, 300 mm SHALL BE SURFACE COURSE MIX 38 mm THICK.

BITUMINOUS CONCRETE PAVEMENT (FULL DEPTH), SUPERPAVE, 290 mm SHALL BE BINDER COURSES ONLY AND THE TOP LIFT OF BINDER SHALL BE 38 mm THICK.

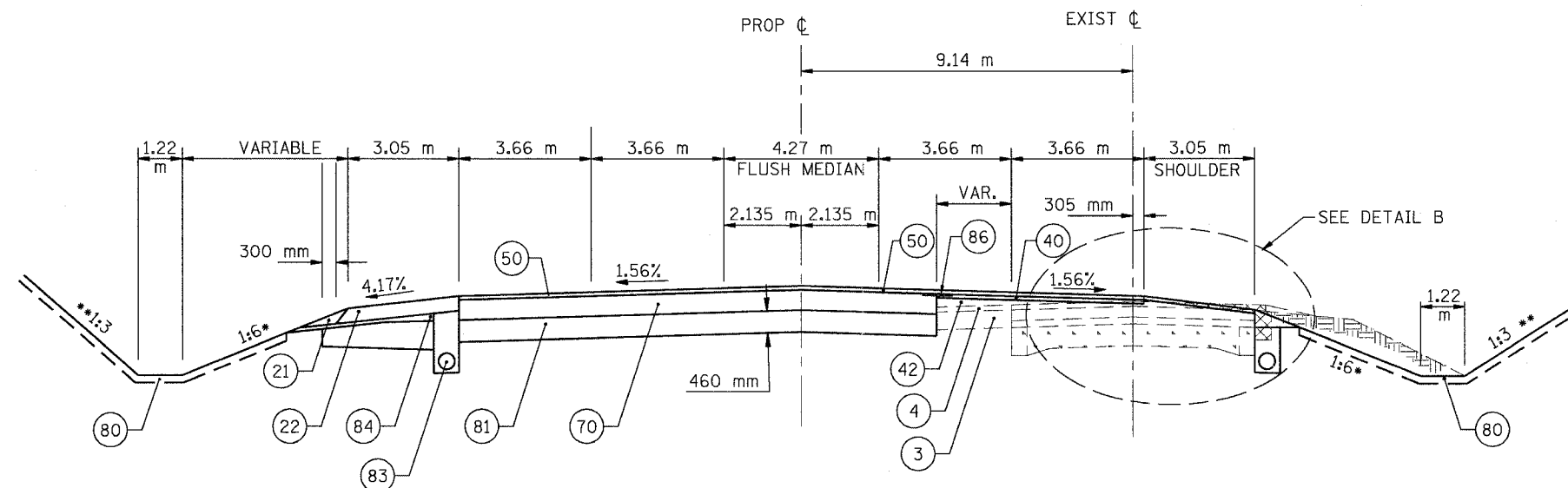

STATION 14+810 TO 14+937

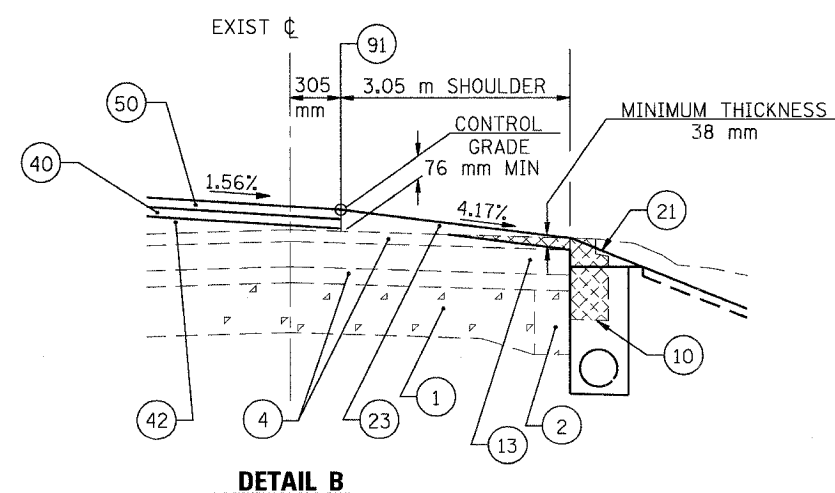

DETAIL B

* OR AS SHOWN ON CROSS SECTIONS (1:4 MAX)

** OR AS SHOWN ON CROSS SECTIONS

REVISIONS	
NAME	DATE

ILLINOIS DEPARTMENT OF TRANSPORTATION

**TYPICAL SECTIONS
ILLINOIS ROUTE 40**

SCALE: NONE
DATE: 09/01/06

DRAWN BY: JDU
CHECKED BY: ECM