

FRAMING PLAN



	0.4 Sp. 1 0.6 Sp. 5	Pier 1 Pier 4	0.5 Sp. 2 0.5 Sp. 4	Pier 2 Pier 3	0.5 Sp. 3
I	(in ⁴) 90956		90956		90956
I'	(in ⁴) 257302		257302		257302
S _b	(in ³) 5153		5153		5153
S _b '	(in ³) 8502		8502		8502
S _t	(in ³) 3736		3736		3736
S _t '	(in ³) 13368		13368		13368
Q	(k/')	1.050	1.050		1.050
M _Q	(k')	864	849		853
s _Q	(k/')	0.355	0.355	0.355	0.355
M _{sQ}	(k)	188	244	80	179
M _L	(k)	478	382	389	351
M (Imp)	(k)	116	92	94	84

I and I' are the moment of inertia and composite moment of inertia of the beam section.
 S_b and S_b' are the non-composite and composite section modulus for the bottom fiber of the prestressed beam.
 S_t and S_t' are the non-composite and composite section modulus for the top fiber of the prestressed beam.
 M_Q is the moment due to dead loads on the non-composite prestressed beam. It is conservatively calculated at 0.5 of the span.
 M_{sQ} is the moment due to dead loads on the composite section.
 M_L is the moment due to live load on the composite section.
 M (Imp) is the moment due to live load impact on the composite section.
 R (Total) is the sum of the reaction per bearing due to R_Q (non-composite) + R_{sQ} (composite) + R_L + I (Composite).

	S. Abutment N. Abutment	Pier 1, Span 1 Pier 4, Span 5	Pier 1, Span 2 Pier 4, Span 4	Pier 2, Span 2 Pier 3, Span 4	Pier 2, Span 3 Pier 3, Span 3
R _Q	(k) 42.3	42.3	42.0	42.0	42.1
R _{sQ}	(k) 11.6	16.6	16.6	14.3	14.3
R _L	(k) 30.7	33.3	32.1	32.3	32.2
R (Imp)	(k) 7.4	8.0	7.7	7.8	7.8
R Total	(k) 92.0	100.2	98.4	96.4	96.4

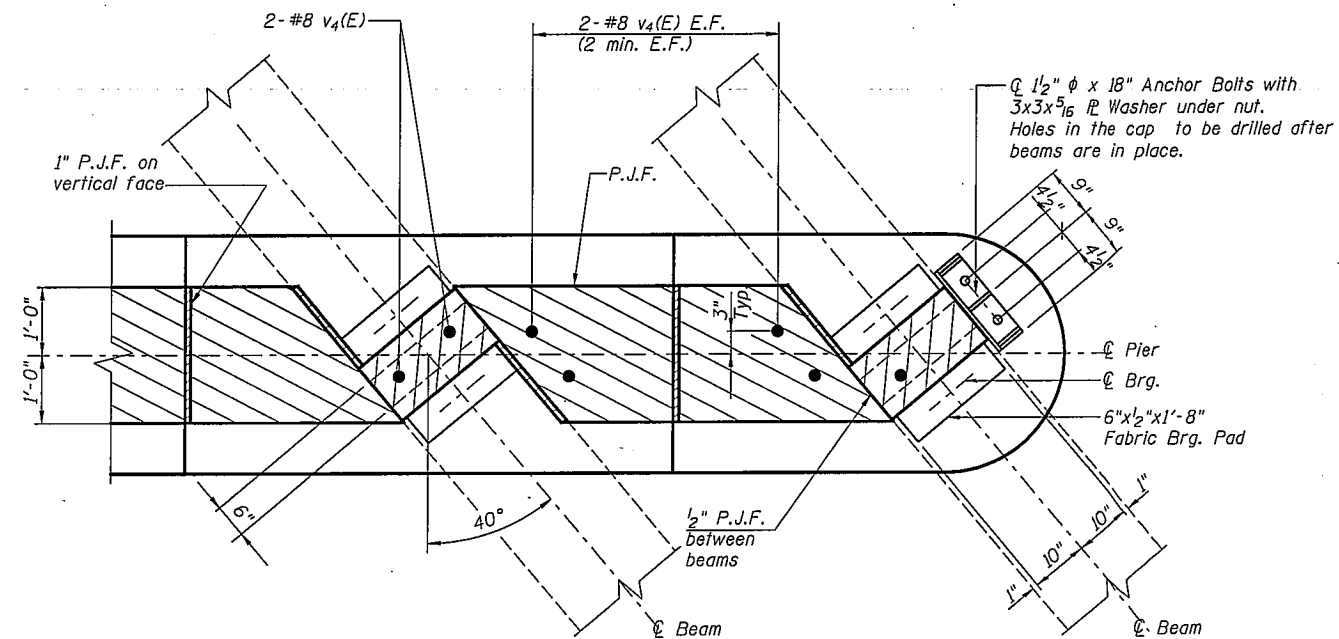

PLAN VIEW OF FIXED PIER

(Piers 2 & 3)

FRAMING PLAN
 U.S. ROUTE 136/IL. ROUTE 1 OVER
 NORTH FORK VERMILION RIVER
 F.A.P. ROUTE 332 SEC. RX-1-BR-1
 VERMILION COUNTY
 STATION 198+63.75
 STRUCTURE NO. 092-0205

CHAMPAIGN, ILLINOIS
 CHICAGO, ILLINOIS
 EVANSVILLE, INDIANA
 INDIANAPOLIS, INDIANA
 KENOSHA, WISCONSIN
 SPRING GREEN, WISCONSIN

REVISIONS	NAME	DATE

INFORMATIONAL DATA IS NOT TO BE DETAINED BY SCALING AND PORTION OF THIS DRAWING.

DESIGNED BY: JXX	CHECKED BY: 182288
DRAWN BY: HEV	DATE: X/85
CHECKED BY: NHM	
APPROVED BY: KXX	
ACTIVITY	DETAILS

DRAWING NUMBER
 S-12