

F.A.S. RTE.	SECTION	COUNTY	TOTAL SHEETS	SHEET NO.
642	99-00124-01-PV	COLES	157	1

D-95-025-97

FOR INDEX OF SHEETS, SEE SHEET 2
 FOR LIST OF STANDARDS, SEE SHEET 2
 FOR GENERAL NOTES, SEE SHEET 13

STATE OF ILLINOIS
 DEPARTMENT OF TRANSPORTATION
 DIVISION OF HIGHWAYS

**PLANS FOR PROPOSED
 FEDERAL AID HIGHWAY**

F.A.S. ROUTE 642 (C.H. 18)
 SECTION 99-00124-01-PV
 PROJECT HPD-ACSA-1037(004)
 C.H. 18 RECONSTRUCTION
 COLES COUNTY
 C-95-078-03

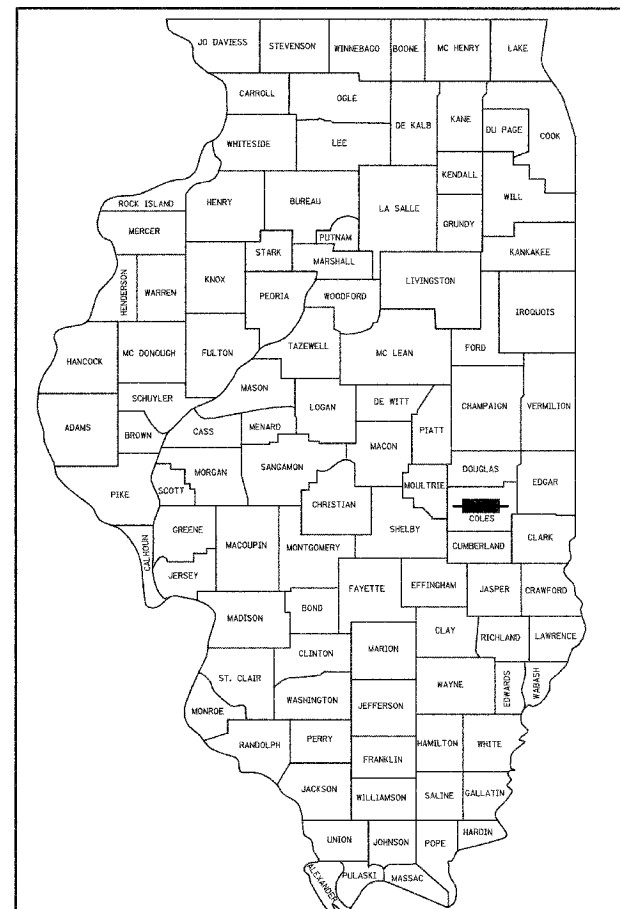

LOCATION OF SECTION INDICATED THUS: - [black box] -

UTILITY NOTE
 THE LOCATION OF THOSE BURIED AND ABOVEGROUND UTILITIES SHOWN ARE APPROXIMATE, ARE SHOWN FOR CONTRACTOR INFORMATIONAL USE ONLY, AND ARE NOT TO BE REFERENCE FOR CONSTRUCTION PURPOSES. THE IMPLIED PRESENCE OR ABSENCE OF UTILITIES IS NOT TO BE CONSTRUED BY THE OWNER, ENGINEER, CONTRACTOR, OR SUBCONTRACTORS TO BE AN ACCURATE AND COMPLETE REPRESENTATION OF UTILITIES THAT MAY OR MAY NOT EXIST ON THE CONSTRUCTION SITE. BURIED AND ABOVEGROUND UTILITY LOCATION, IDENTIFICATION, AND MARKINGS ARE THE SOLE RESPONSIBILITY OF THE CONTRACTOR, REROUTING, DISCONNECTION, PROTECTION, ETC. OF ANY UTILITIES MUST BE COORDINATED BETWEEN THE CONTRACTOR, UTILITY COMPANY, AND OWNER. SITE SAFETY, INCLUDING THE AVOIDANCE OF HAZARDS ASSOCIATED WITH BURIED AND ABOVEGROUND UTILITIES, REMAIN THE SOLE RESPONSIBILITY OF THE CONTRACTOR.

J.U.L.I.E.
 JOINT UTILITY LOCATION INFORMATION FOR EXCAVATION
 1-800-892-0123
 NORTH OKAW TOWNSHIP
 MATTOON TOWNSHIP
 HUMBOLDT TOWNSHIP
 LAFAYETTE TOWNSHIP

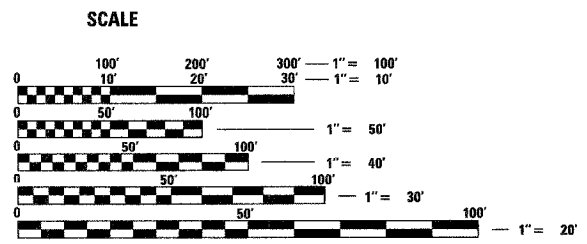
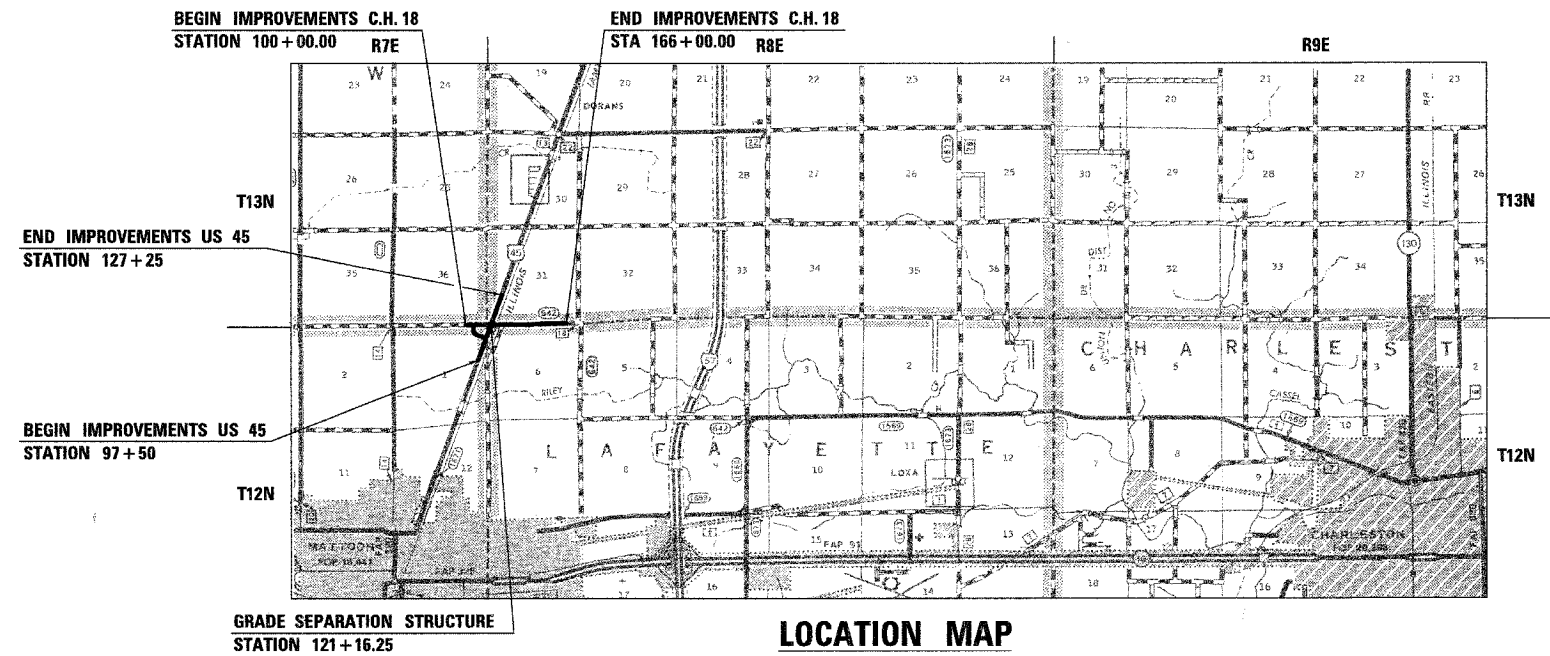

TOTAL LENGTH OF F.A.S. 642 IMPROVEMENT = 6,600 LIN. FT. = 1.250 MILES
 NET LENGTH OF F.A.S. 642 IMPROVEMENT = 6,600 LIN. FT. = 1.250 MILES
 TOTAL LENGTH OF US 45 IMPROVEMENT = 2,811 LIN. FT. = 0.532 MILES
 NET LENGTH OF US 45 IMPROVEMENT = 2,811 LIN. FT. = 0.532 MILES

FULL SIZE PLANS HAVE BEEN PREPARED USING STANDARD ENGINEERING SCALES. REDUCED SIZED PLANS WILL NOT CONFORM TO STANDARD SCALES. IN MAKING MEASUREMENTS ON REDUCED PLANS, THE ABOVE SCALES MAY BE USED.

TRAFFIC DATA
 DESIGN DESIGNATION: ADT = 8,400
 MAJOR COLLECTOR DESIGN SPEED = 60 mph

The Upchurch Group, Inc.
 engineers architects surveyors environmental consultants
 1810 CHARLESTON AVE. MATTOON, ILLINOIS 61938 (217) 235-3177
 PROFESSIONAL DESIGN FIRM LICENSE NO. 184-003401



STATE OF ILLINOIS
 DEPARTMENT OF TRANSPORTATION
 DIVISION OF HIGHWAYS

SUBMITTED Sept 12 2005
 Releasing For Bid Based on Limited Review [Signature] REGIONAL ENGINEER
 9/13 20 05
 PASSED [Signature] DISTRICT ENGINEER OF LOCAL ROADS AND STREETS
 August 22 20 05
[Signature] COLES COUNTY ENGINEER

**PRINTED BY THE AUTHORITY
 OF THE STATE OF ILLINOIS**

F.A.S. RTE.	SECTION	COUNTY	TOTAL SHEETS	SHEET NO.
642	99-00124-01-PV	COLES	157	2
STA.		TO STA.		
FED. ROAD DIST. NO.		ILLINOIS FED. AID PROJECT		

INDEX OF SHEETS

1	COVER SHEET
2	INDEX OF SHEETS AND HIGHWAY STANDARDS
3-4	EXISTING TYPICAL SECTIONS
5-12	PROPOSED TYPICAL SECTIONS
13	GENERAL NOTES
14-16	SUMMARY OF QUANTITIES
17-20	SCHEDULE OF QUANTITIES
21-22	GEOMETRIC CONTROL
23-24	CROSS TIES AND BENCHMARKS
25-29	PLAN AND PROFILE SHEETS - PROPOSED C.H. 18
30-31	PLAN AND PROFILE SHEETS - JUGHANDLE
32-34	PLAN AND PROFILE SHEETS - US RTE 45
35	PLAN AND PROFILE SHEETS- LOGAN ST.
36	PLAN AND PROFILE SHEETS- DRAINAGE EASEMENT
37-40	REMOVAL PLANS
41-44	PAVEMENT MARKINGS
45-48	INTERSECTION DETAILS
49-50	MASTERFOODS U.S.A. ENTRANCE PLAN
51-54	PAVEMENT JOINTING PLAN
55-56	SIGNING PLAN
57-60	DETOUR PLAN
61-63	STAGING PLAN
64-72	EROSION CONTROL PLANS
73	DETENTION AREA GRADING PLAN
74-83	MISCELLANEOUS DETAILS
84-104	BRIDGE PLANS
105	BRIDGE APPROACH PAVEMENT SPECIAL
106-108	MECHANICAL STABILIZED EARTH WALL
109-137	CROSS SECTIONS - PROPOSED C.H. 18
138-142	CROSS SECTIONS - JUGHANDLE
143-151	CROSS SECTIONS - US RTE 45
152	CROSS SECTIONS - MASTERFOODS USA ENTRANCE
153	CROSS SECTIONS - DRAINAGE EASEMENT
154-157	R.O.W. PLANS

ILLINOIS DOT HIGHWAY STANDARDS (IN PROPOSAL BOOKLET)

000001-04	STANDARD SYMBOLS, ABBREVIATIONS, AND PATTERNS
001001	AREAS OF REINFORCEMENT REBARS
001006	DECIMAL OF AN INCH AND A FOOT
280001-02	TEMPORARY EROSION CONTROL SYSTEMS
420001-06	PAVEMENT JOINTS
420101-03	24' JOINTED PCC PAVEMENT
420401-05	BRIDGE APPROACH PAVEMENT
442201-01	CLASS C & D PATCHES
482006-01	BITUMINOUS SHOULDER ADJACENT TO RIGID PAVEMENT
515001-02	NAME PLATE FOR BRIDGES
542301	PRECAST REINFORCED CONCRETE FLARED END SECTION
542306	PRECAST REINFORCED CONCRETE ELLIPTICAL FLARED END SECTION
542401	METAL END SECTION FOR PIPE <i>CULVERTS</i>
602301	INLET TYPE A
602401	MANHOLE TYPE A
602601	PRECAST REINFORCED CONCRETE FLAT SLAB TOP
602701	CAST IRON STEPS
604001-02	FRAME AND LIDS TYPE 1
604006-02	TYPE 3 FRAME & GRATE
604036-01	TYPE 8 GRATE
606001-02	CONCRETE CURB TYPE B AND COMBINATION CURB AND GUTTER
606301-02	PC CONCRETE ISLANDS AND MEDIANS
606401	PAVED DITCH
610001-02	SHOULDER INLET WITH CURB
630001-05	STEEL PLATE BEAM GUARDRAIL
630301-03	SHOULDER WIDENING FOR TYPE 1 GUARDRAIL TERMINAL
631031-05	TRAFFIC BARRIER TERMINAL TYPE 6
635001	DELINEATORS
635006-02	REFLECTOR AND TERMINAL MARKER PLACEMENT
635011-01	REFLECTIVE MARKER AND MOUNTING DETAILS
641006	SIGHTSCREEN WOODPLANK FENCE, TYPE P
666001	RIGHT OF WAY MARKERS
667101	PERMANENT SURVEY MARKERS
701001-01	OFF-RD OPERATION 2L, 2W, 4.5 m (15') MIN. AWAY FOR SPEEDS > 45 mph
701006-02	OFF-RD OPERATION 2L, 2W, 4.5 m (15') TO PAVEMENT EDGE FOR SPEEDS > 45 mph
701011-01	OFF-RD OPERATION MOVING OPERATIONS 2L, 2W DAY ONLY FOR SPEEDS > 45 mph
701201-02	LANE CLOSURE, 2L, 2W DAY ONLY ON-RD TO 600 mm (24") OFF-RD FOR SPEEDS > 45 mph
701301-02	LANE CLOSURE, 2L, 2W SHORT TERM OPERATIONS
701306-01	LANE CLOSURE, 2L, 2W SLOW MOVING OPERATIONS-DAY ONLY FOR SPEEDS > 45 mph
701311-02	LANE CLOSURE 2L, 2W MOVING OPERATIONS-DAY ONLY
701326-02	LANE CLOSURE 2L, 2W PAVEMENT WIDENING FOR SPEEDS > 45 mph
702001-05	TRAFFIC CONTROL DEVICES
704001-02	TEMPORARY CONCRETE BARRIERS
720001	SIGN PANEL MOUNTING DETAILS
720006	SIGN PANEL ERECTION DETAILS
720011	METAL POSTS FOR SIGNS, MARKERS & DELINEATORS
729001	APPLICATIONS OF TYPES A & B METAL POSTS (FOR SIGNS & MAKERS)
780001-01	TYPICAL PAVEMENT MARKINGS
781001-02	TYPICAL APPLICATIONS RAISED REFLECTIVE PAVEMENT MARKERS
BLR 21-6	TYPICAL APPLICATION OF TRAFFIC CONTROL DEVICES FOR CONSTRUCTION ON RURAL LOCAL HIGHWAYS
BLR 22-4	TYPICAL APPLICATION OF TRAFFIC CONTROL DEVICES FOR CONSTRUCTION ON RURAL LOCAL HIGHWAYS (TWO-LANE TWO WAY RURAL TRAFFIC) (ROAD CLOSED TO THRU TRAFFIC)
BLR 24-1	MAILBOX TURNOUT FOR LOCAL ROADS

TUG PROJ. #1997022-5
 SHEET-M.dgn
 04/04/2005

REVISIONS	
NAME	DATE

ILLINOIS DEPARTMENT OF TRANSPORTATION

INDEX OF SHEETS AND HIGHWAY STANDARDS

SCALE: VERT.
 HORIZ.
 DATE 04/04/2005

DRAWN BY SJF
 CHECKED BY MED

F.A.S. RTE.	SECTION	COUNTY	TOTAL SHEETS	SHEET NO.
642	99-00124-01-PV	COLES	157	3
STA.		TO STA.		
FED. ROAD DIST. NO.		ILLINOIS	FED. AID PROJECT	

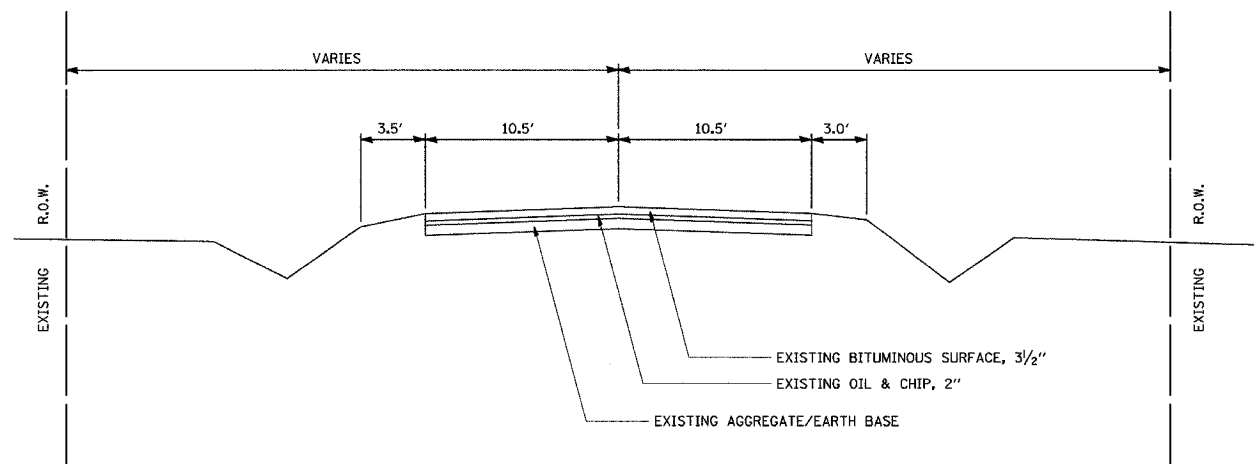

EXISTING TYPICAL SECTION 1

COUNTY HIGHWAY 18

STA. 100+00 TO STA. 119+25

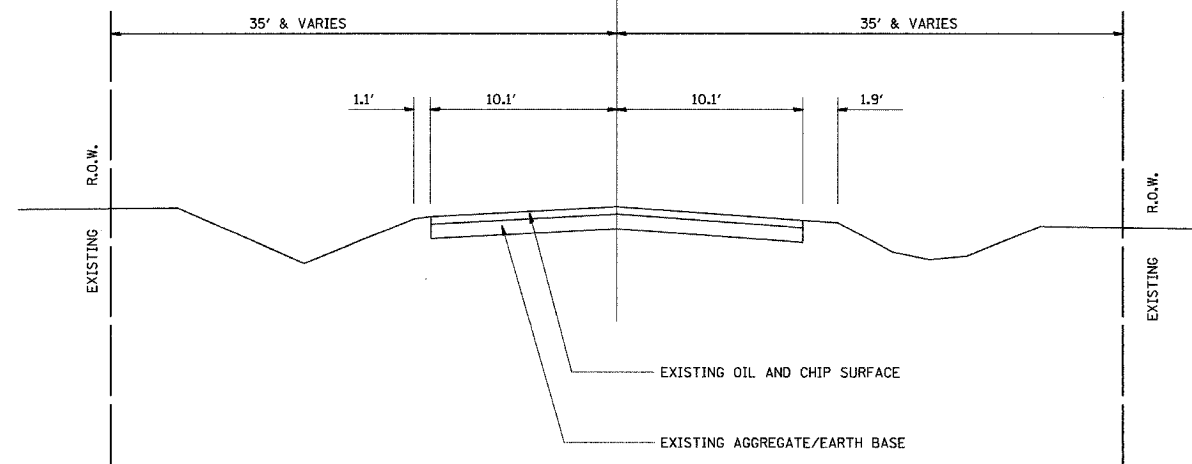

EXISTING TYPICAL SECTION 3

COUNTY HIGHWAY 18

STA. 143+13 TO STA. 166+00

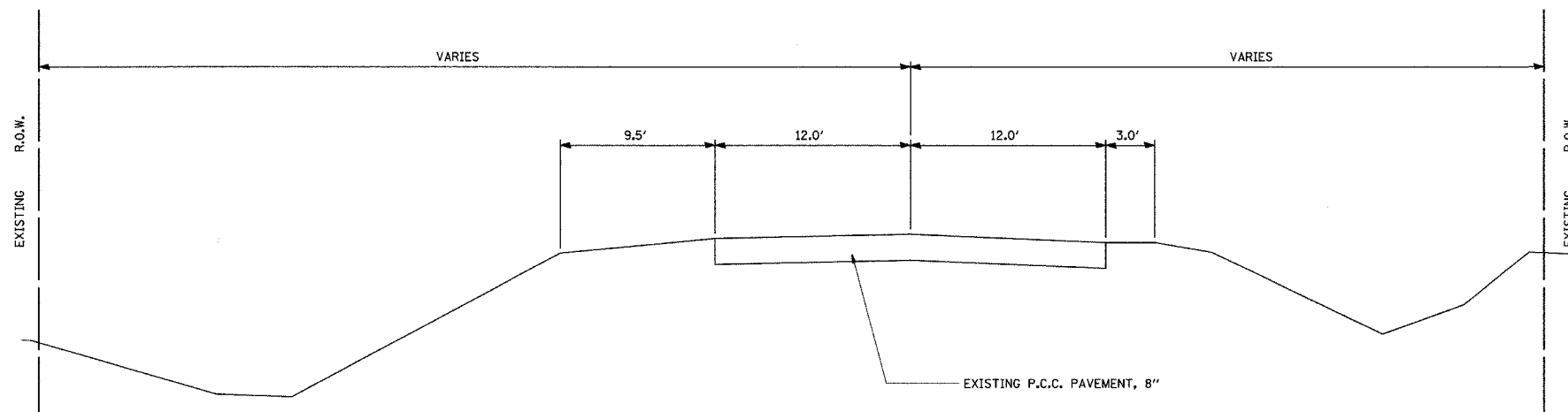

EXISTING TYPICAL SECTION 2

COUNTY HIGHWAY 18

STA. 119+25 TO STA. 143+13

NOTE: THIS TYPICAL SECTION IS ALSO THE EXISTING TYPICAL SECTION FOR PROPOSED TYPICAL SECTIONS 13 AND 14. (MASTERFOODS PARKING LOT ENTRANCE)

REVISIONS	
NAME	DATE

ILLINOIS DEPARTMENT OF TRANSPORTATION

**EXISTING TYPICAL SECTIONS
U.S. ROUTE 45**

SCALE: VERT.
HORIZ.
DATE 04/04/2005

DRAWN BY SJF
CHECKED BY MED

TUC PROJ. #13191022-5
SHEET-W-001
04/04/2005

F.A.S. RTE.	SECTION	COUNTY	TOTAL SHEETS	SHEET NO.
642	99-00124-01-PV	COLES	157	4
STA.	TO STA.			
FED. ROAD DIST. NO.	ILLINOIS	FED. AID PROJECT		

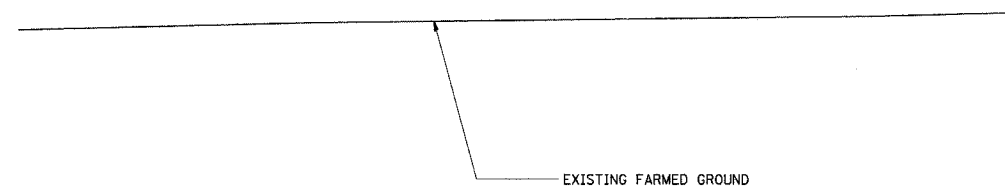

EXISTING TYPICAL SECTION 4

JUGHANDLE

STA. 100+30 TO STA. 116+28.11

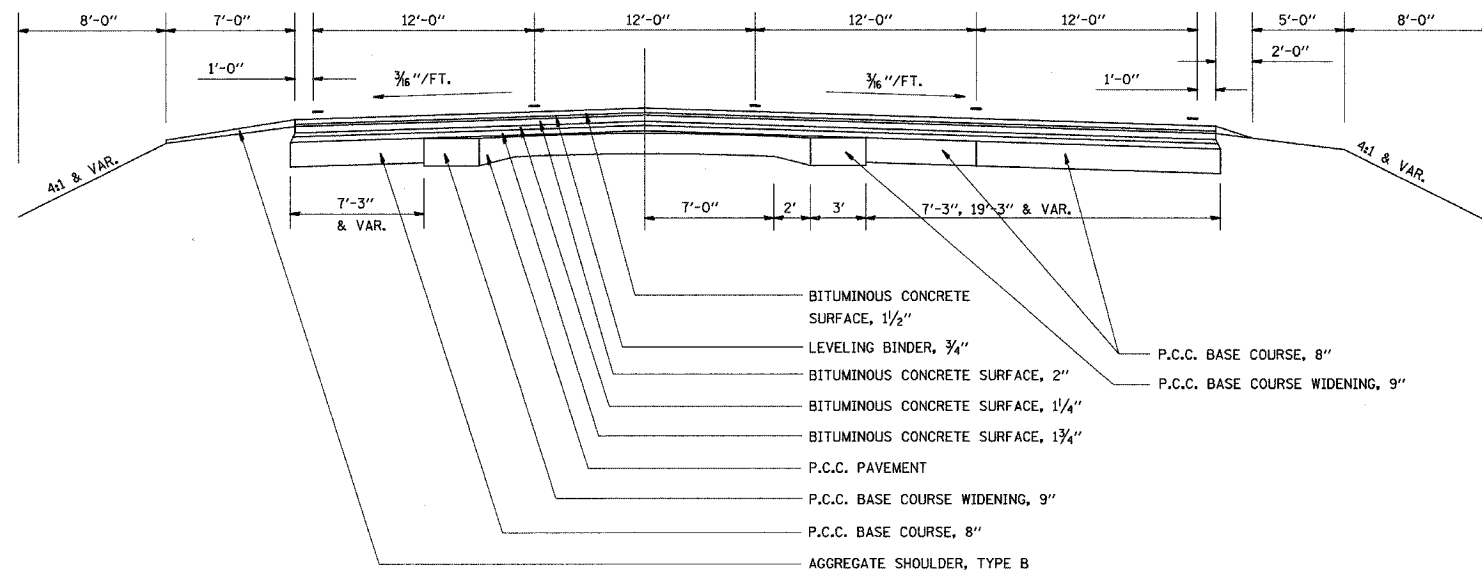

EXISTING TYPICAL SECTION 6

U.S. ROUTE 45

STA. 114+29.41 TO STA. 127+50.00

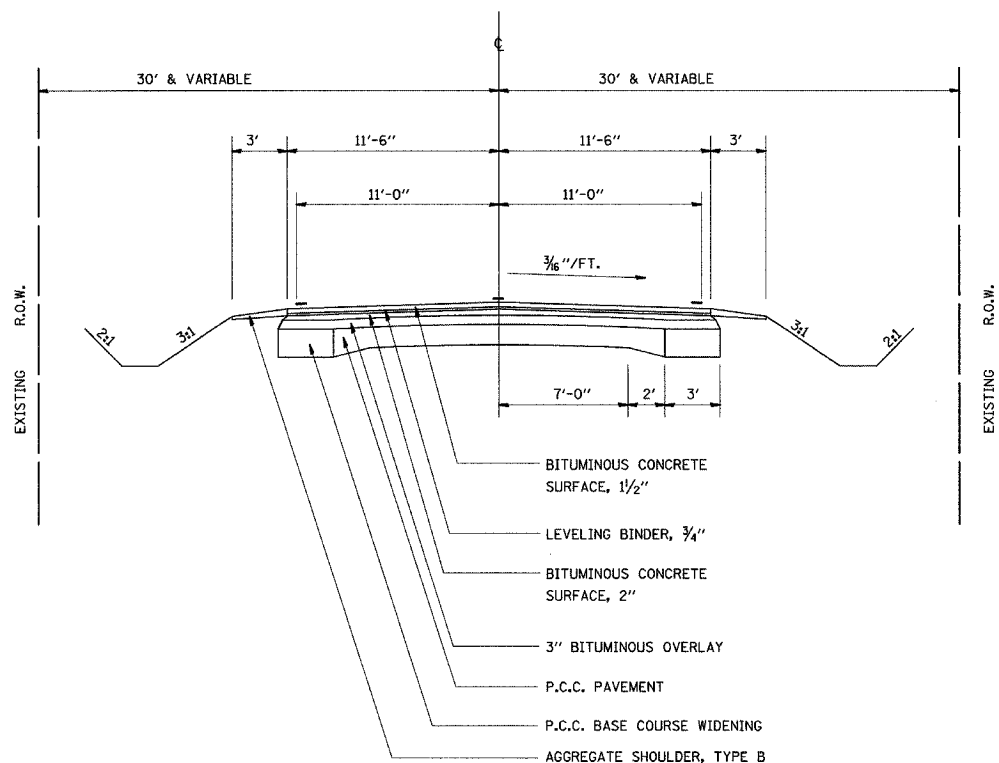

EXISTING TYPICAL SECTION 5

U.S. ROUTE 45

STA. 97+14 TO STA. 114+29.41

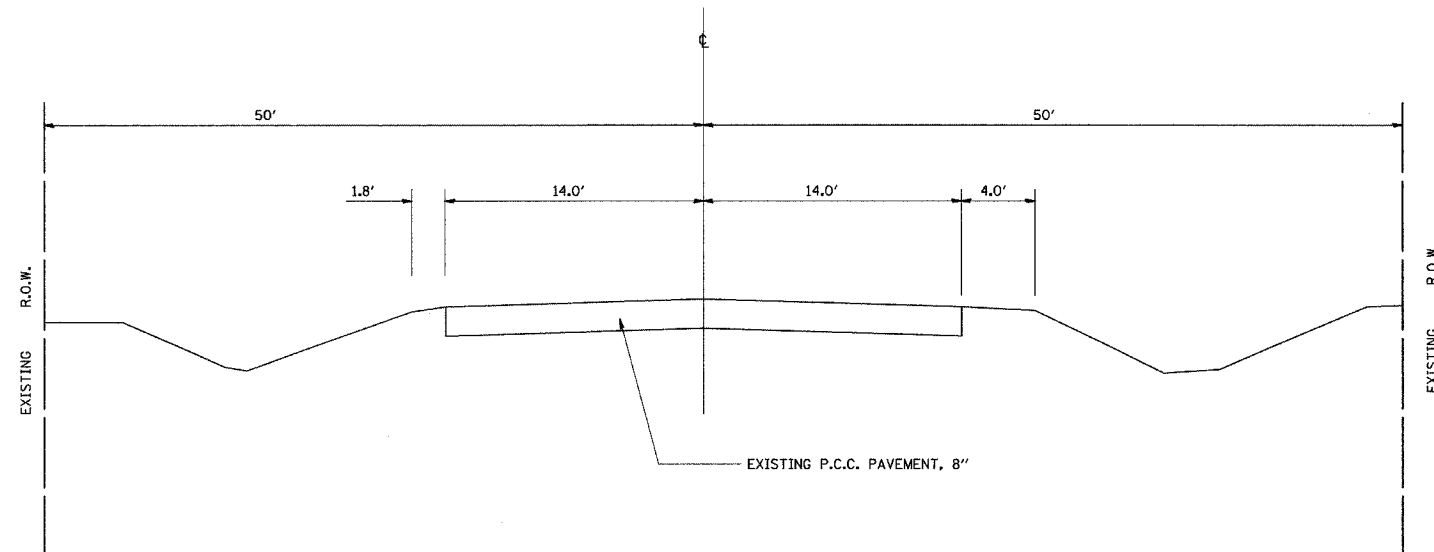

EXISTING TYPICAL SECTION 7

LOGAN STREET

STA. 8+50 TO STA. 10+00

REVISIONS	
NAME	DATE

ILLINOIS DEPARTMENT OF TRANSPORTATION

EXISTING TYPICAL SECTIONS

SCALE: VERT.
HORIZ.
DATE 04/04/2005

DRAWN BY SJF
CHECKED BY MED

TUG PROJ. #3197022-5
SHEET-N.dgn
04/04/2005

F.A.S. RTE.	SECTION	COUNTY	TOTAL SHEETS	SHEET NO.
642	99-00124-01-PV	COLES	157	5
STA. TO STA.		TO STA.		
FED. ROAD DIST. NO.		ILLINOIS	FED. AID PROJECT	

① PROPOSED TYPICAL CROSS SECTION
COUNTY HIGHWAY 18

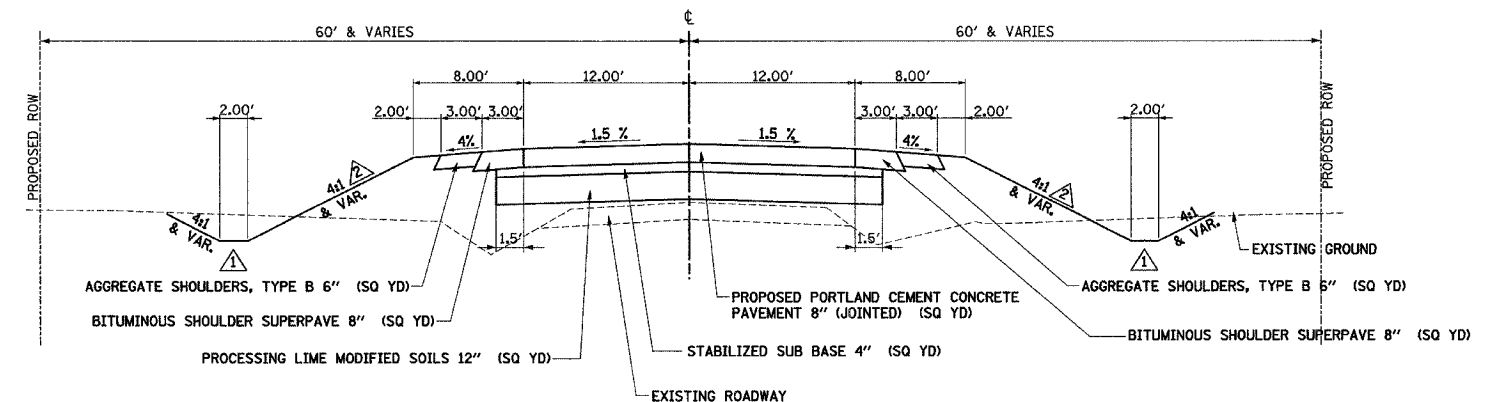

① STA 100+00.00 TO STA 100+60.90 ②
② STA 143+25.00 TO STA 161+98.47 ②

STRUCTURAL DESIGN TRAFFIC (2015) = 5080
PV = 90%, SU = 6%, MU = 4%
PERCENT OF STRUCTURAL DESIGN TRAFFIC IN DESIGN LANE = 50%
CLASS II ROAD
TRAFFIC FACTOR = 1.13
EXISTING A.D.T. = 1,200 V.P.D. STA. 100+00.00 TO STA. 100+59.55
EXISTING A.D.T. = 2,300 V.P.D. STA. 149+27.64 TO STA. 166+00.00

NOTES : SEE CROSS SECTIONS FOR DITCH ELEVATIONS
 FOR FILL SLOPES GREATER THAN 25', USE 2:1 SLOPES WITH GUARDRAIL.

② PROPOSED TYPICAL CROSS SECTION
COUNTY HIGHWAY 18

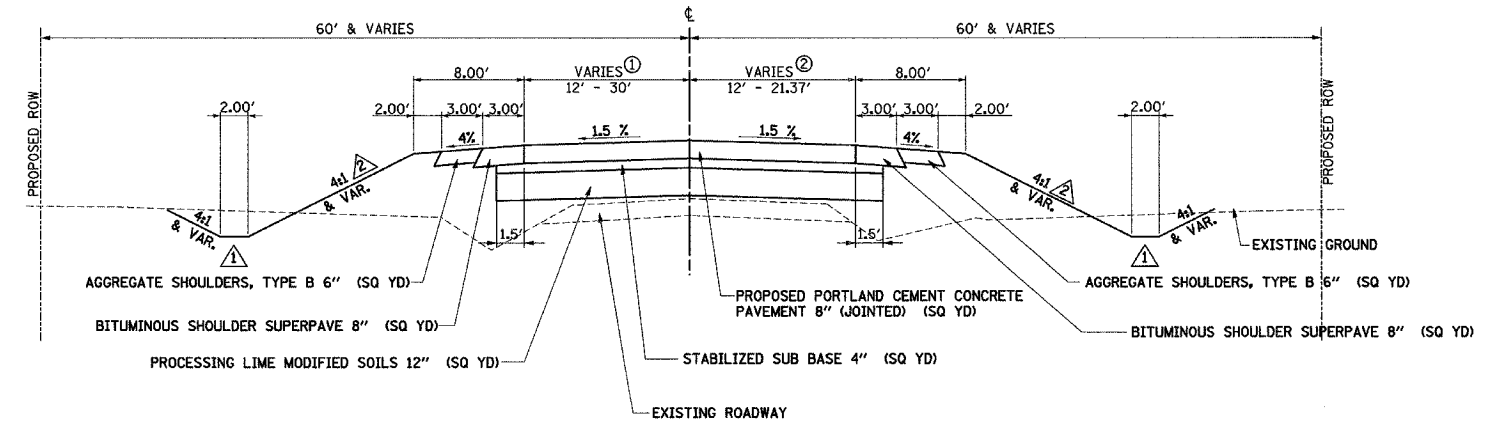

① 12.00' TO 12.80' STA 100+60.90 TO STA 102+01.30
12.80' TO 18.00' STA 102+01.30 TO STA 107+33.11
18.00' TO 30.00' STA 107+33.11 TO STA 108+16.81

30.00' TO 24.80' STA 137+31.00 TO STA 137+85.25
30.00' TO 24.80' STA 137+85.25 TO STA 140+45.49
24.80' TO 12.00' STA 140+45.49 TO STA 143+25.00

12.00' TO 18.00' STA 161+98.47 TO STA 164+99.74
18.00' TO 18.00' STA 164+99.74 TO STA 166+00.00

② 12.00' TO 26.60' STA 100+60.90 TO STA 103+41.30
26.60' TO 30.00' STA 103+41.30 TO STA 106+16.32
30.00' TO 18.00' STA 106+16.32 TO STA 108+16.81

18.00' TO 12.00' STA 137+31.00 TO STA 137+85.32
18.00' TO 12.00' STA 137+85.32 TO STA 140+85.29
12.00' TO 12.00' STA 140+85.29 TO STA 143+25.00

12.00' TO 12.00' STA 161+98.47 TO STA 162+01.16
12.00' TO 18.00' STA 162+01.16 TO STA 165+02.83
18.00' TO 21.37' STA 165+02.83 TO STA 166+00.00

① STA 100+60.90 TO STA 108+16.81 ③
③ STA 137+31.00 TO STA 143+25.00 ①
① STA 161+98.47 TO STA 166+00.00

STRUCTURAL DESIGN TRAFFIC (2015) = 5080
PV = 90%, SU = 6%, MU = 4%
PERCENT OF STRUCTURAL DESIGN TRAFFIC IN DESIGN LANE = 50%
CLASS II ROAD
TRAFFIC FACTOR = 1.13
EXISTING A.D.T. = 1,200 V.P.D. STA. 100+59.55 TO STA 108+11.77
EXISTING A.D.T. = 2,300 V.P.D. STA. 137+28.00 TO STA. 149+27.64

NOTES : SEE CROSS SECTIONS FOR DITCH ELEVATIONS
 FOR FILL SLOPES GREATER THAN 25', USE 2:1 SLOPES WITH GUARDRAIL.

REVISIONS		ILLINOIS DEPARTMENT OF TRANSPORTATION
NAME	DATE	
		<p>PROPOSED TYPICAL SECTIONS COUNTY HIGHWAY 18</p> <p>SCALE: VERT. DRAWN BY SJF HORIZ. CHECKED BY MED DATE 08/11/2005</p>

TUG PROJ. #1387022-5
...SHEET-W.dgn
08/11/2005

F.A.S. RTE.	SECTION	COUNTY	TOTAL SHEETS	SHEET NO.
642	99-00124-01-PV	COLES	157	6
STA. TO STA.		TO STA.		
FED. ROAD DIST. NO.		ILLINOIS	FED. AID PROJECT	

③ PROPOSED TYPICAL CROSS SECTION COUNTY HIGHWAY 18

(BA) = BRIDGE APPROACH

- ① 18.00' STA 108+16.81 TO STA 110+54.52
- 18.00' TO 12.00' STA 110+54.52 TO STA 115+44.36
- 12.00' STA 115+44.36 TO STA 120+00.67
- 18.00' STA 134+50.00 TO STA 135+00.19
- 18.00' TO 30.00' STA 135+00.19 TO STA 136+06.79
- 30.00' STA 136+06.79 TO STA 137+31.00

- ② 18.00' STA 108+16.81 TO STA 111+96.74
- 18.00' TO 12.00' STA 111+96.74 TO STA 117+33.66
- 12.00' STA 117+33.66 TO STA 120+00.67
- 18.00' STA 134+50.00 TO STA 137+31.00

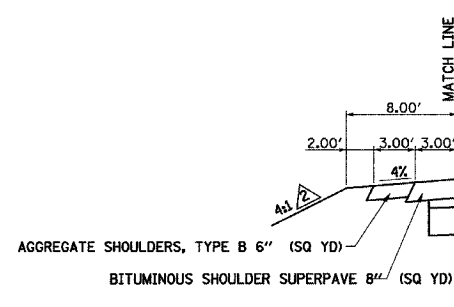

LT STA 108+11.77 TO STA 109+76.85
LT STA 135+32.37 TO STA 137+28.00

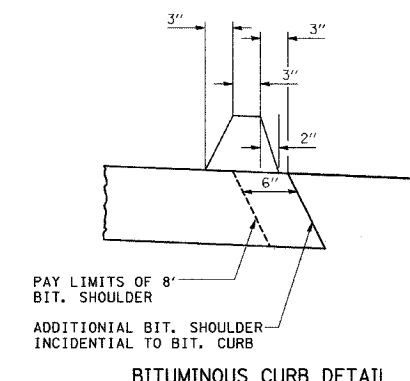
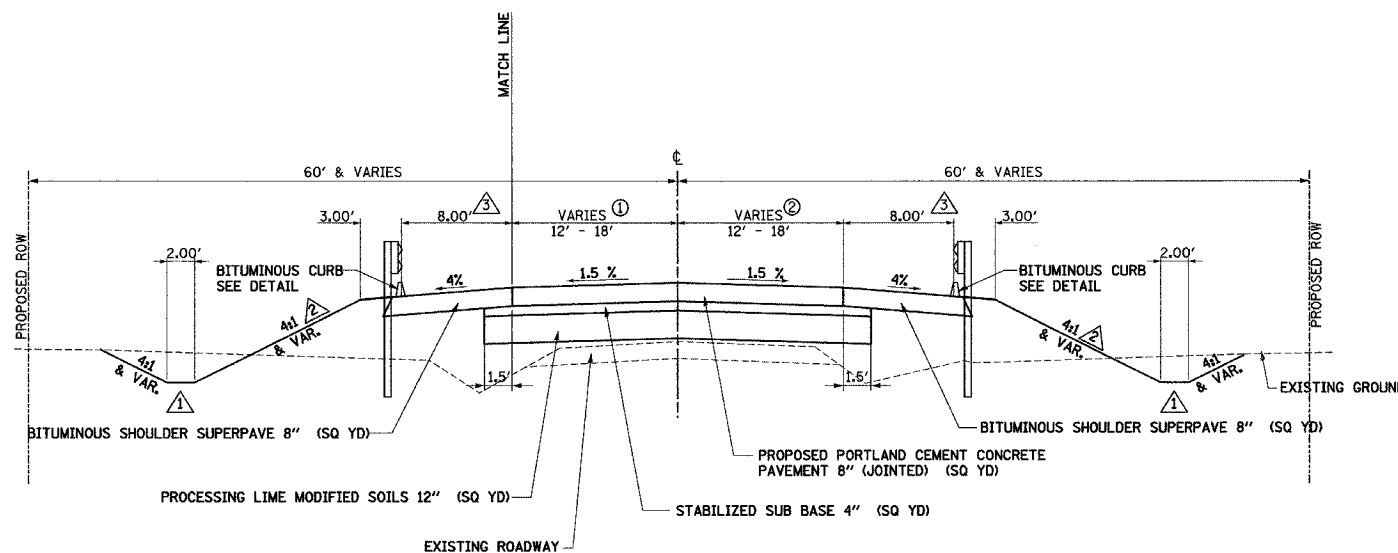

- NOTES :
- ▲ SEE CROSS SECTIONS FOR DITCH ELEVATIONS
 - ▲ FOR FILL SLOPES GREATER THAN 25', USE 2:1 SLOPES WITH GUARDRAIL.
 - ▲ FLARE SHOULDER OUT WITH GUARDRAIL AT TERMINAL END SECTIONS

- ② STA 108+11.77 TO STA 120+00.67 (BA)
- ④ STA 134+50.00 TO STA 137+31.00 ②

STRUCTURAL DESIGN TRAFFIC (2015) = 5080
PV = 90%, SU = 6%, MU = 4%
PERCENT OF STRUCTURAL DESIGN TRAFFIC IN DESIGN LANE = 50%
CLASS II ROAD
TRAFFIC FACTOR = 1.13
EXISTING A.D.T. = 2,500 V.P.D. STA. 134+50.07 TO STA. 137+28.00
EXISTING A.D.T. = 1,200 V.P.D. STA. 108+11.77 TO STA. 120+00.67

④ PROPOSED TYPICAL CROSS SECTION COUNTY HIGHWAY 18

(BA) = BRIDGE APPROACH

- ① 12.00' STA 123+71.40 TO STA 127+74.29
- 12.00' TO 18.00' STA 127+74.29 TO STA 130+74.29
- 18.00' STA 130+74.29 TO STA 134+50.00

- ② 12.00' STA 123+71.40 TO STA 127+74.29
- 12.00' TO 18.00' STA 127+74.29 TO STA 130+74.29
- 18.00' STA 130+74.29 TO STA 134+50.00

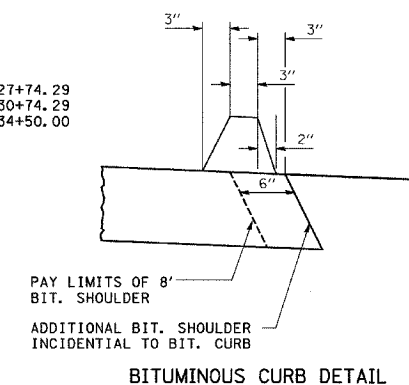
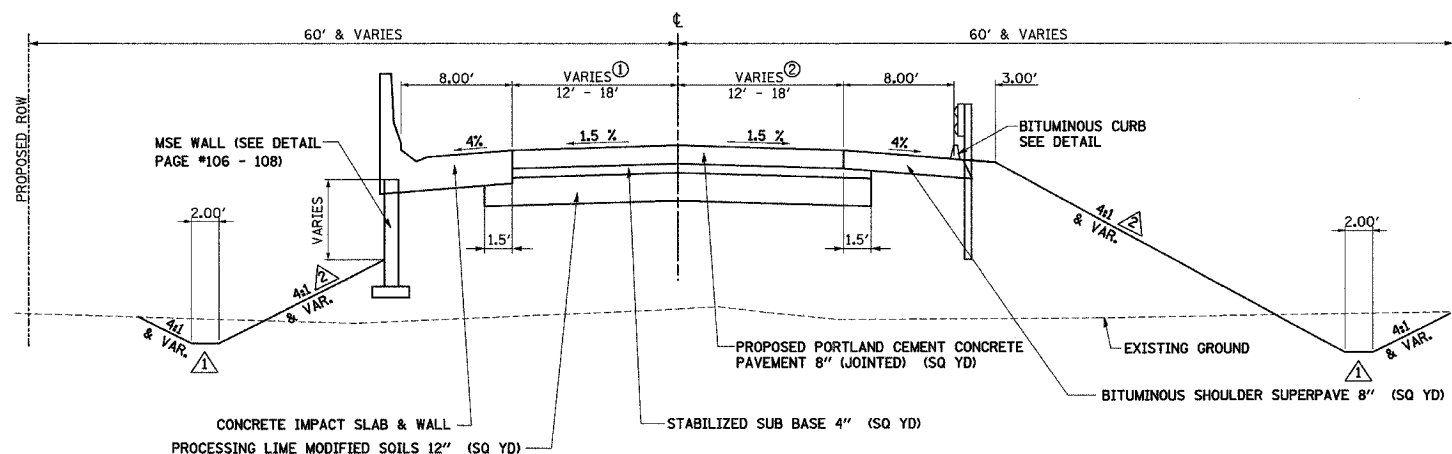

- NOTES :
- ▲ SEE CROSS SECTIONS FOR DITCH ELEVATIONS
 - ▲ FOR FILL SLOPES GREATER THAN 25', USE 2:1 SLOPES WITH GUARDRAIL.
 - ▲ FLARE SHOULDER OUT WITH GUARDRAIL AT TERMINAL END SECTIONS

- (BA) STA 123+71.40 TO STA 134+50.00 ③

STRUCTURAL DESIGN TRAFFIC (2015) = 5080
PV = 90%, SU = 6%, MU = 4%
PERCENT OF STRUCTURAL DESIGN TRAFFIC IN DESIGN LANE = 50%
CLASS II ROAD
TRAFFIC FACTOR = 1.13
EXISTING A.D.T. = 2,300 V.P.D.

REVISIONS	
NAME	DATE

ILLINOIS DEPARTMENT OF TRANSPORTATION
**PROPOSED TYPICAL SECTIONS
COUNTY HIGHWAY 18**

SCALE: VERT.
HORIZ.
DATE 08/11/2005

DRAWN BY SJF
CHECKED BY MED

F.A.S. RTE.	SECTION	COUNTY	TOTAL SHEETS	SHEET NO.
642	99-00124-01-PV	COLES	157	7
STA.		TO STA.		
FED. ROAD DIST. NO.		ILLINOIS FED. AID PROJECT		

⑤ PROPOSED TYPICAL CROSS SECTION JUGHANDLE

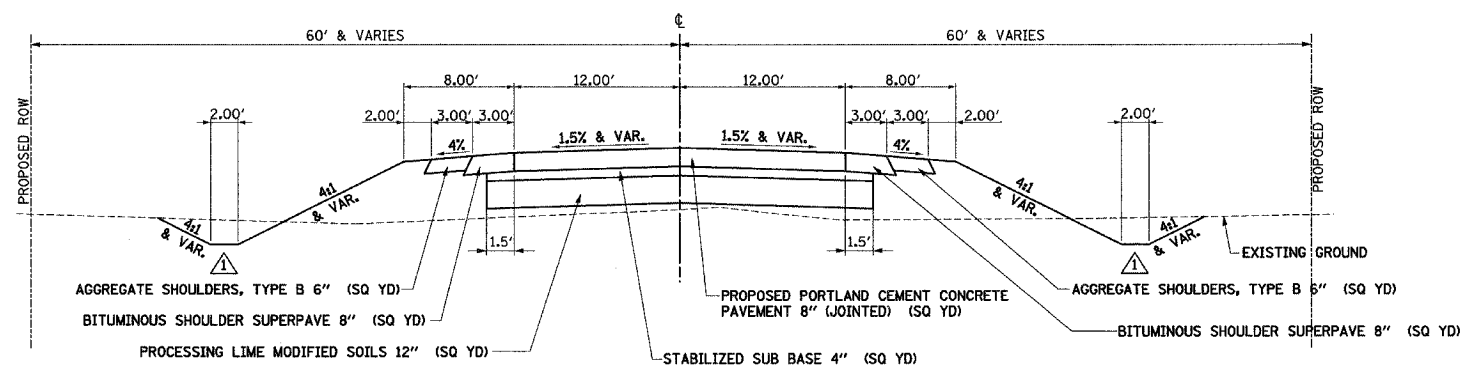

STA 100+30.00 TO STA 100+82.26 ⑥

STRUCTURAL DESIGN TRAFFIC (2015) = 4200
 PV = 92%, SU = 6%, MU = 2%
 PERCENT OF STRUCTURAL DESIGN TRAFFIC IN DESIGN LANE = 50%
 CLASS II ROAD

NOTES : △ SEE CROSS SECTIONS FOR DITCH ELEVATIONS

⑥ PROPOSED TYPICAL CROSS SECTION JUGHANDLE

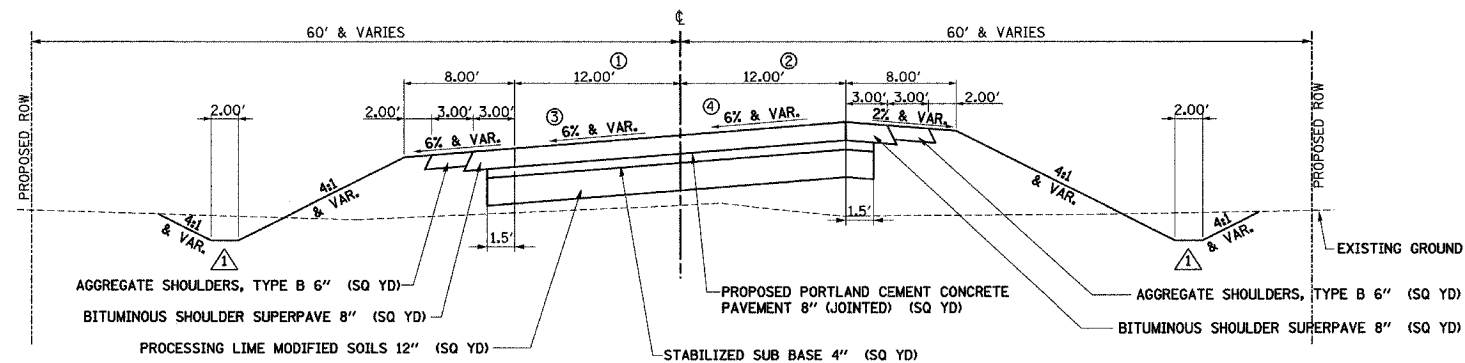

⑤ STA 100+82.26 TO STA 110+38.51 ⑦

- ① 12.00' TO 14.64' STA 109+19.88 TO STA 110+38.51
- ③ -1.5% TO -6.0% STA 100+82.26 TO STA 101+57.26
 -1.5% TO -6.0% STA 101+57.26 TO STA 102+69.76
 -6.0% TO -1.5% STA 102+69.76 TO STA 108+51.01
 -6.0% TO -1.5% STA 108+51.01 TO STA 109+63.51
 -1.5% TO -1.5% STA 109+63.51 TO STA 110+38.51

- ② 12.00' TO 14.64' STA 109+19.88 TO STA 110+38.51
- ④ -1.5% TO 6.0% STA 100+82.26 TO STA 102+69.76
 6.0% TO 6.0% STA 102+69.76 TO STA 108+51.01
 6.0% TO -1.5% STA 108+51.01 TO STA 110+38.51

REVISIONS	
NAME	DATE

ILLINOIS DEPARTMENT OF TRANSPORTATION

PROPOSED TYPICAL SECTIONS
 JUGHANDLE

SCALE: VERT.
 HORIZ.
 DATE 04/04/2005

DRAWN BY SJF
 CHECKED BY MED

TUG PROJ. #1817022-5
 SHEET-W.dgn
 04/04/2005

F.A.S. RTE.	SECTION	COUNTY	TOTAL SHEETS	SHEET NO.
642	99-00124-01-PV	COLES	157	8
STA. TO STA.		TO STA.		
FED. ROAD DIST. NO.		ILLINOIS FED. AID PROJECT		

⑦ PROPOSED TYPICAL CROSS SECTION
JUGHANDLE

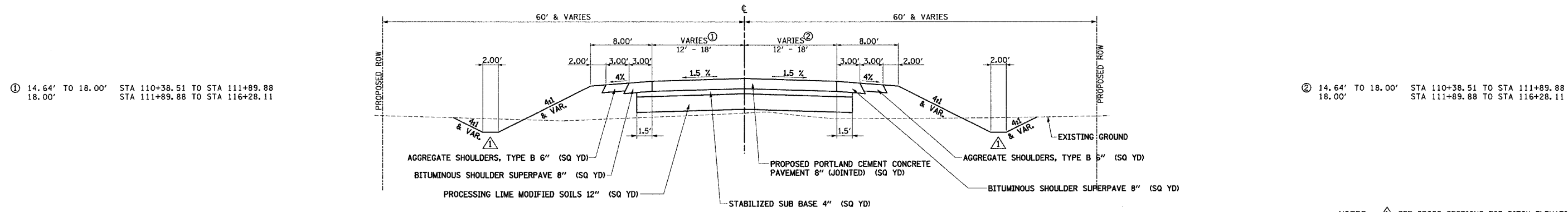

NOTES : SEE CROSS SECTIONS FOR DITCH ELEVATIONS

STRUCTURAL DESIGN TRAFFIC (2015) = 4200
PV = 92%, SU = 6%, MU = 2%
PERCENT OF STRUCTURAL DESIGN TRAFFIC IN DESIGN LANE = 50%
CLASS II ROAD

⑥ STA 110+38.51 TO STA 116+28.11

⑧ PROPOSED TYPICAL CROSS SECTION
U.S. RTE. 45

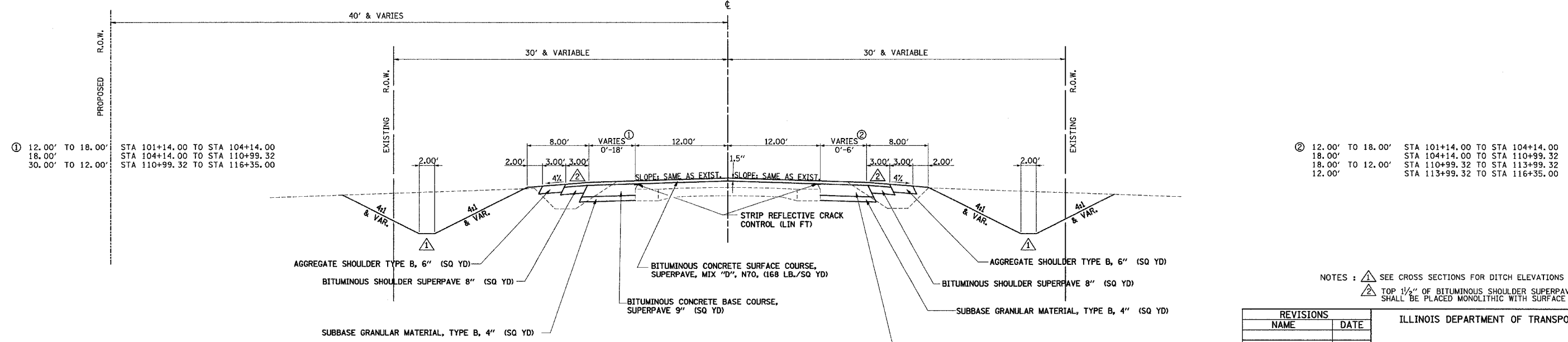

NOTES : SEE CROSS SECTIONS FOR DITCH ELEVATIONS
 TOP 1/2" OF BITUMINOUS SHOULDER SUPERPAVE SHALL BE PLACED MONOLITHIC WITH SURFACE COURSE

STRUCTURAL DESIGN TRAFFIC (2015) = 6675
PV = 92%, SU = 5%, MU = 3%
PERCENT OF STRUCTURAL DESIGN TRAFFIC IN DESIGN LANE = 50%
CLASS II ROAD

STA 101+14.00 TO STA 116+35.00 ⑨

REVISIONS	
NAME	DATE

ILLINOIS DEPARTMENT OF TRANSPORTATION

**PROPOSED TYPICAL SECTIONS
U.S. ROUTE 45**

SCALE: VERT. DRAWN BY SJF
 HORIZ. CHECKED BY MED
DATE 08/22/2005

TUG PROJ. #13197022-5
SHEET W-401
08/22/2005

F.A.S. RTE.	SECTION	COUNTY	TOTAL SHEETS	SHEET NO.
642	99-00124-01-PV	COLES	157	9
STA.		TO STA.		
FED. ROAD DIST. NO.		ILLINOIS FED. AID PROJECT		

9 PROPOSED TYPICAL CROSS SECTION
U.S. RTE. 45

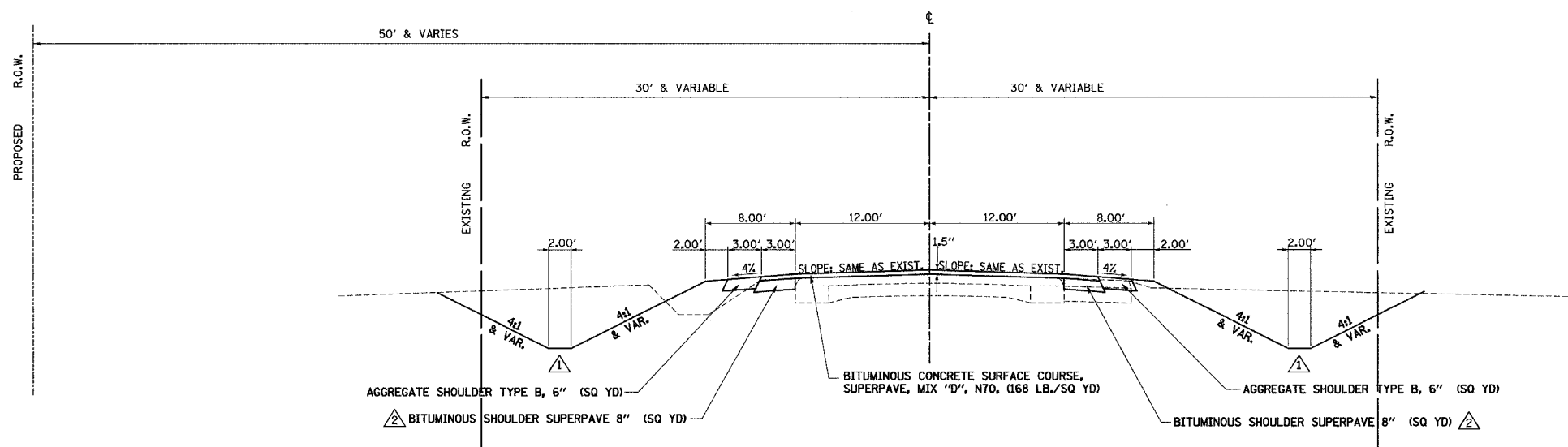

NOTES : \triangle SEE CROSS SECTIONS FOR DITCH ELEVATIONS
 \triangle TOP 1 1/2" OF BITUMINOUS SHOULDER SUPERPAVE SHALL BE PLACED MONOLITHIC WITH SURFACE COURSE

STRUCTURAL DESIGN TRAFFIC (2015) = 6675
 PV = 92%, SU = 5%, MU = 3%
 PERCENT OF STRUCTURAL DESIGN TRAFFIC IN DESIGN LANE = 50%
 CLASS II ROAD

8 STA 116+35.00 TO STA 121+00.00 10

10 PROPOSED TYPICAL CROSS SECTION
U.S. RTE. 45

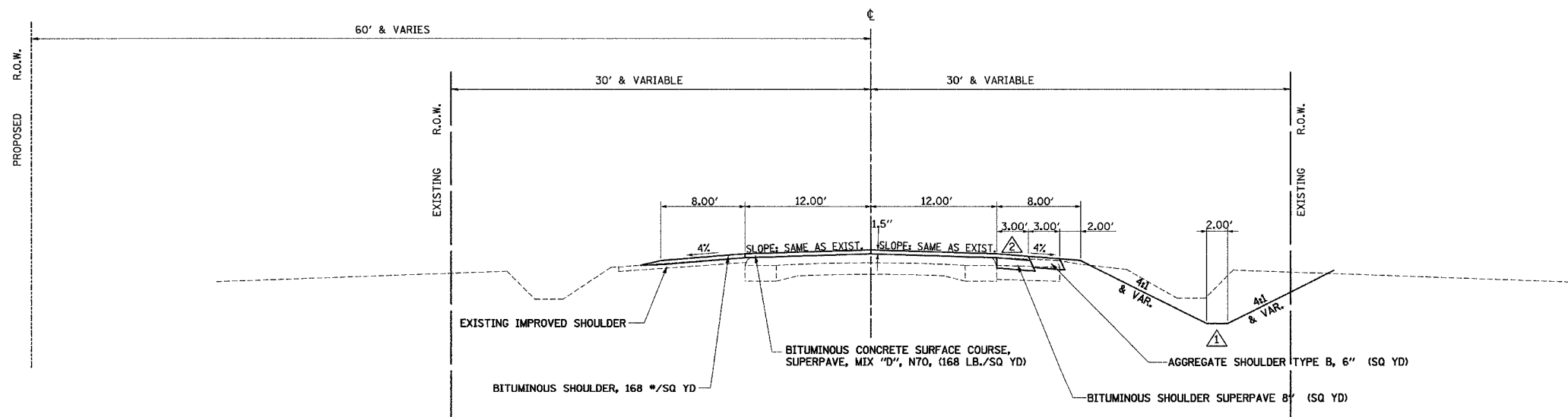

NOTES : \triangle SEE CROSS SECTIONS FOR DITCH ELEVATIONS
 \triangle TOP 1 1/2" OF BITUMINOUS SHOULDER SUPERPAVE SHALL BE PLACED MONOLITHIC WITH SURFACE COURSE

STRUCTURAL DESIGN TRAFFIC (2015) = 6675
 PV = 92%, SU = 5%, MU = 3%
 PERCENT OF STRUCTURAL DESIGN TRAFFIC IN DESIGN LANE = 50%
 CLASS II ROAD

9 STA 121+00.00 TO STA 127+25.00

REVISIONS	
NAME	DATE

ILLINOIS DEPARTMENT OF TRANSPORTATION
PROPOSED TYPICAL SECTIONS
U.S. ROUTE 45 & LOGAN STREET
 SCALE: VERT. _____
 HORIZ. _____
 DATE 08/22/2005
 DRAWN BY SJF
 CHECKED BY MED

TUC PROJ. #13197022-5
 SHEET-W4.dgn
 08/22/2005

F.A.S. RTE.	SECTION	COUNTY	TOTAL SHEETS	SHEET NO.
642	99-00124-01-PV	COLES	157	10
STA.		TO STA.		
FED. ROAD DIST. NO.		ILLINOIS FED. AID PROJECT		

⑪ PROPOSED TYPICAL CROSS SECTION
LOGAN STREET

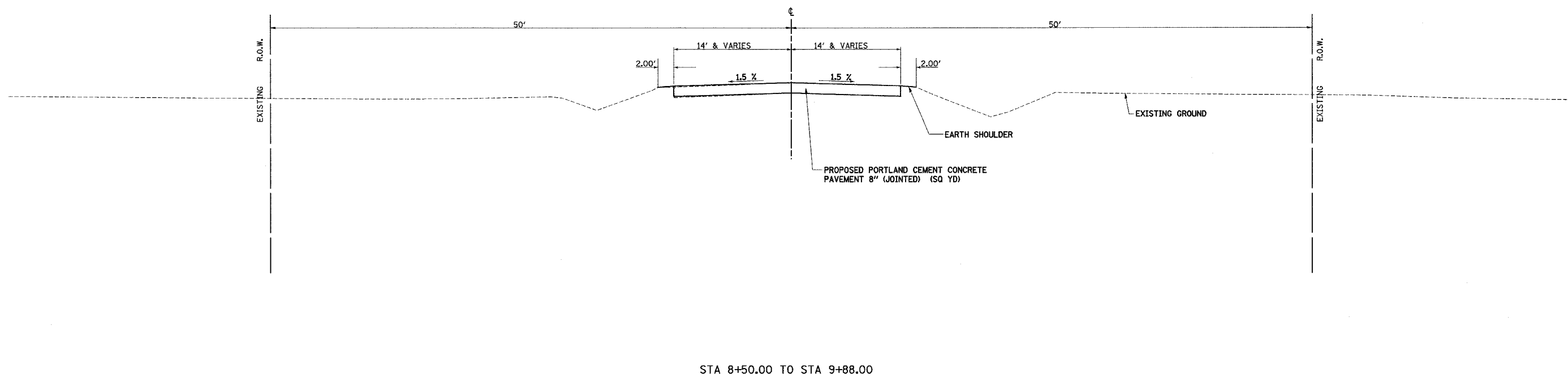

⑫ PROPOSED TYPICAL CROSS SECTION
TEMPORARY ENTRANCE

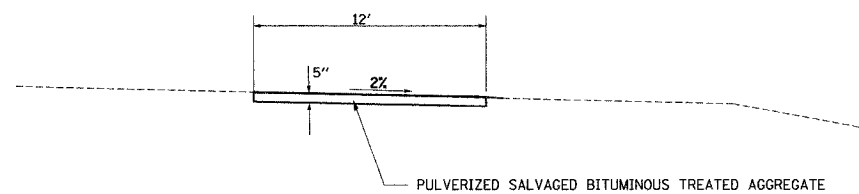

REVISIONS	
NAME	DATE

ILLINOIS DEPARTMENT OF TRANSPORTATION

PROPOSED TYPICAL SECTIONS

SCALE: VERT.
HORIZ.
DATE 04/04/2005

DRAWN BY RLH
CHECKED BY MED

TUG PROJ. #1917022-5
SHEET-W.dgn
04/04/2005

F.A.S. RTE.	SECTION	COUNTY	TOTAL SHEETS	SHEET NO.
642	99-00124-01-PV	COLES	157	11
STA.		TO STA.		
FED. ROAD DIST. NO.		ILLINOIS FED. AID PROJECT		

13 PROPOSED TYPICAL CROSS SECTION
MASTERFOODS PARKING LOT ENTRANCE

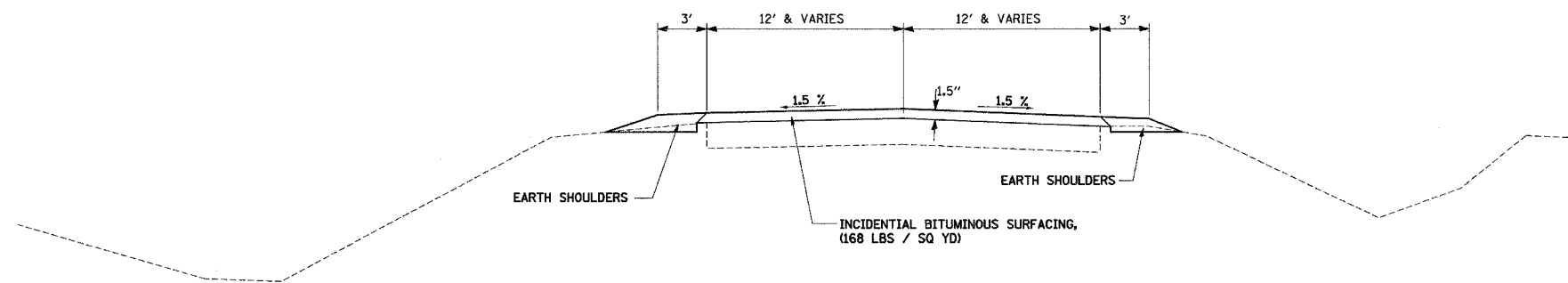

STA 3+16.62 TO STA 5+73.31 14

14 PROPOSED TYPICAL CROSS SECTION
MASTERFOODS PARKING LOT ENTRANCE

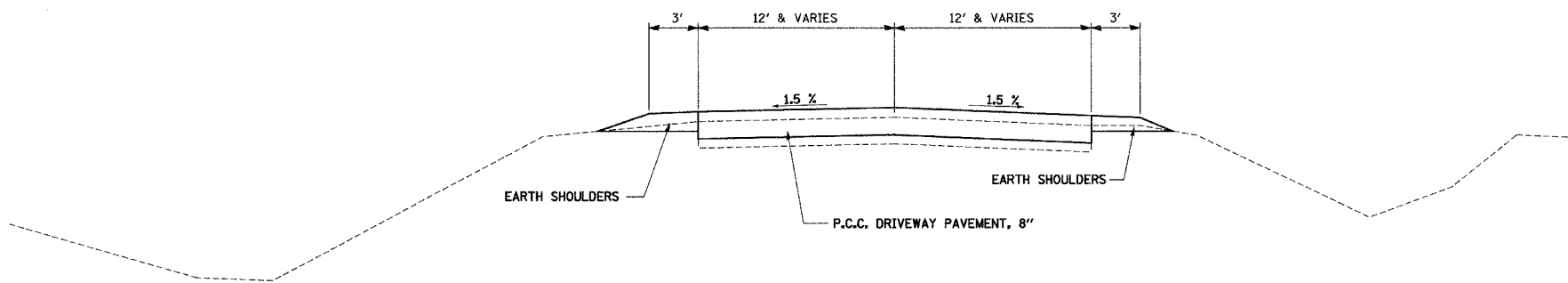

13 STA 5+73.31 TO STA 9+82.60

REVISIONS	
NAME	DATE

ILLINOIS DEPARTMENT OF TRANSPORTATION

PROPOSED TYPICAL SECTIONS

SCALE: VERT. DRAWN BY RLH
 HORIZ. CHECKED BY MED
 DATE 04/04/2005

TUG PROJ. #13191022-5
 ...SHEET-W.dgn
 04/04/2005

F.A.S. RTE.	SECTION	COUNTY	TOTAL SHEETS	SHEET NO.
642	99-00124-01-PV	COLES	157	12
STA.		TO STA.		
FED. ROAD DIST. NO.		ILLINOIS FED. AID PROJECT		

15 PROPOSED TYPICAL CROSS SECTION
MASTERFOODS TRUCK ENTRANCE

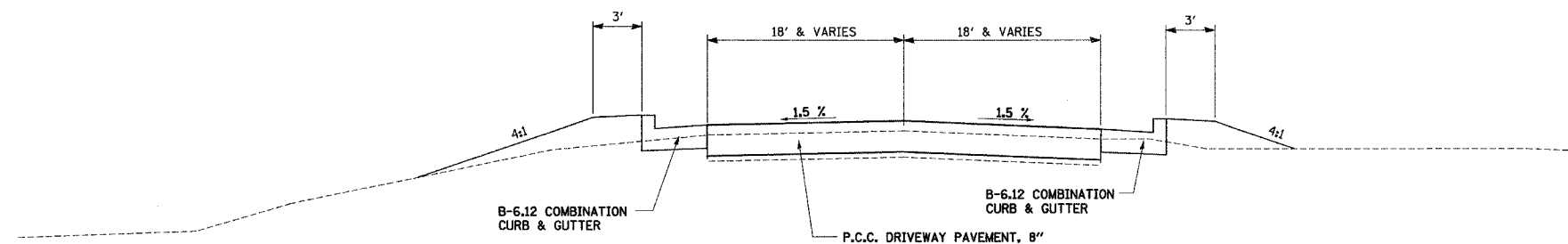

STA 20+30.00 TO STA 25+26.43

16 PROPOSED TYPICAL CROSS SECTION
EXISTING C.H. 18 WIDENING

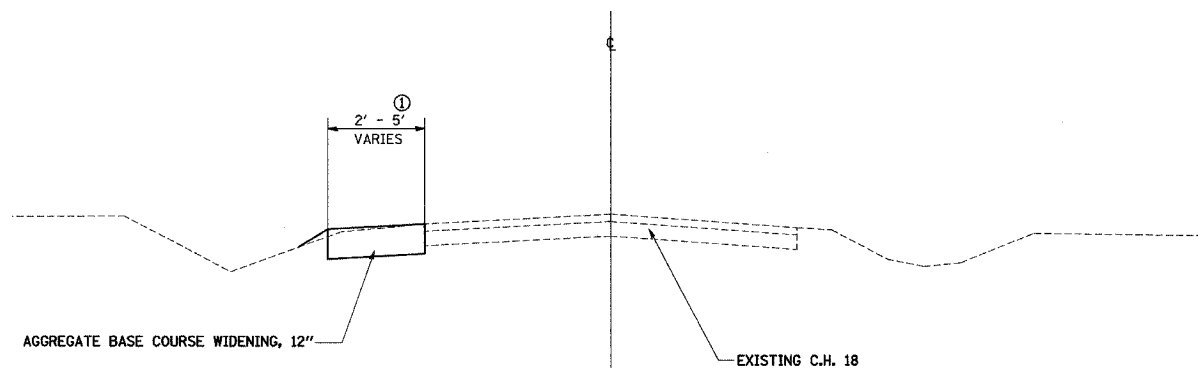

- ① 2' STA 146+00 TO STA 147+00
- 2' TO 3' STA 147+00 TO STA 148+00
- 3' STA 148+00 TO STA 155+00
- 3' TO 5' STA 155+00 TO STA 156+00
- 5' STA 156+00 TO STA 158+00
- 5' TO 2' STA 158+00 TO STA 159+00

TUG PROJ. #13191022-5
SHEET-W.dgn
04/04/2005

REVISIONS	
NAME	DATE

ILLINOIS DEPARTMENT OF TRANSPORTATION

PROPOSED TYPICAL SECTIONS

SCALE: VERT.
HORIZ.
DATE 04/04/2005

DRAWN BY RLH
CHECKED BY MED

F.A.S. RTE.	SECTION	COUNTY	TOTAL SHEETS	SHEET NO.
642	99-00124-01-PV	COLES	157	13
STA.		TO STA.		
FED. ROAD DIST. NO.	ILLINOIS	FED. AID PROJECT		

G.N. -100
ENGLISH UNITS OF MEASUREMENT SHALL GOVERN OVER AND SUPERSEDE ANY METRIC UNITS SHOWN IN THIS CONTRACT. WHERE INCLUDED, METRIC UNITS ARE FOR INFORMATION ONLY.

G.N. -107.20
THE CONTRACTOR SHALL TAKE SPECIAL NOTICE THAT IRON PINS HAVE BEEN SET AT THE CORNERS OF LOCATIONS DESIGNATED IN THE PLANS AS 'PROPOSED RIGHT-OF-WAY'. THE CONTRACTOR SHALL PROTECT AND CAREFULLY PRESERVE ALL OF THESE IRON PINS AS SPECIFIED IN ARTICLE 107. OF THE STANDARD SPECIFICATIONS.

G.N. -107.12
THE NAME, ADDRESS AND TELEPHONE NUMBER OF THE LOCAL RAILROAD CONTACT IS:
HARDY TAYLOR, CANADIAN NATIONAL/ILLINOIS CENTRAL R.R. (217) 238-2443

SPECIAL ATTENTION IS CALLED TO ARTICLE 107.12 REGARDING RAILROAD FLAGGERS.
THE NAME, ADDRESS AND TELEPHONE NUMBER OF THE RAILROAD FLAGGER CONTACT IS:
TOM TUCKER (248) 740-6227

G.N. -107.31
UTILITY LINES WERE PLOTTED FROM INFORMATION FURNISHED BY THE VARIOUS UTILITY COMPANIES INVOLVED (QUALITY LEVEL C &/OR QUALITY LEVEL D) AND THE ACCURACY SHOULD BE CONSIDERED APPROXIMATE ONLY.

UTILITY COMPANIES MAY BE ADJUSTING THEIR FACILITIES DURING CONSTRUCTION. THE CONTRACTOR SHALL COOPERATE WITH THESE ORGANIZATIONS WHILE THESE ADJUSTMENTS ARE BEING PERFORMED. J.U.L.I.E. - UTILITY LOCATION INFORMATION FOR EXCAVATORS SYSTEM (800)892-0123.

G.N. 250C
SEEDING, CLASS 7 AND MULCH, METHOD 2 IS INCLUDED IN THIS CONTRACT TO SEED NEW EARTH SHOULDERS DURING TIME PERIODS WHEN PERMANENT SEEDING IS NOT ALLOWED. SOME OR ALL OF THE CLASS 7 SEEDING AND MULCH WILL BE DELETED IF IT IS POSSIBLE TO PLACE PERMANENT SEEDING ON EARTH SHOULDERS AT THE TIME OF THEIR COMPLETION.

G.N. -406 SP
THE QUANTITIES INCLUDED IN THE PLANS FOR BITUMINOUS CONCRETE RESURFACING ARE INTENDED TO GIVE THE COVERAGE SHOWN ON THE TYPICAL CROSS SECTIONS. IT IS NOT INTENDED TO INCREASE THE THICKNESS OF THE BITUMINOUS MIXTURE IN ORDER TO USE ALL OF THE QUANTITIES INCLUDED IN THE CONTRACT. FOR THE PAY ITEM BITUMINOUS MATERIALS (PRIME COAT), EITHER RC-70 OR AN EMULSIFIED POLYMER PRIME SS-1HP SHALL BE USED.

G.N. -443-SPL
STRIP REFLECTIVE CRACK CONTROL TREATMENT SHALL BE PLACED WHERE THE BITUMINOUS CONCRETE BASE COURSE ABUTS THE EXISTING PAVEMENT AS DIRECTED BY THE ENGINEER.

G.N. -482
ALL MATERIAL PLACED AS BITUMINOUS SHOULDERS SUPERPAVE SHALL BE COMPACTED TO 94.0-98.4 PERCENT OF THE MAXIMUM THEORETICAL DENSITY. THIS REQUIREMENT SHALL APPLY TO BOTH B.A.M. AND IL 9.5L GRADATION SHOULDER MIXES. THIS MAXIMUM DENSITY SHALL BE DETERMINED FROM THE MOVING AVERAGE OF FOUR TESTS AS IN OTHER QC/QA TESTING. A NUCLEAR GAUGE DENSITY/CORE CORRELATION SHALL BE PERFORMED FOR BOTH THE B.A.M. AND IL 9.5L MIXES USING STANDARD CORRELATION PROCEDURES.

G.N. -506
ALL FINAL SURFACES OF THE BEAMS SHALL BE PAINTED WITH LIGHT GREY (MUNSELL COLOR STANDARD - 10Y 7/1) EXCEPT THE EXTERIOR SURFACES OF THE EXTERIOR BEAMS WHICH SHALL BE PAINTED WITH INTERSTATE GREEN (MUNSELL COLOR STANDARD 7.5G 4/8).

G.N. -542
BEFORE ORDERING PIPE CULVERTS, THE CONTRACTOR SHALL CONSULT THE ENGINEER FOR THE EXACT LENGTHS.

G.N. - 542B
ALL THE ENTRANCE CULVERTS LENGTHS SHOWN IN THE PLANS WERE CALCULATED WITH THE ASSUMPTION THAT METAL PIPES AND METAL END SECTIONS WOULD BE USED.

G.N. -542.07
AT LOCATIONS WHERE END SECTIONS ARE SPECIFIED, CAST-IN-PLACE CONCRETE HEADWALLS SHALL NOT BE ALLOWED.

G.N. -550
BEFORE ORDERING STORM SEWERS, THE CONTRACTOR SHALL CONSULT THE ENGINEER FOR THE EXACT LENGTHS.

G.N. -631
IF THE CONTRACTOR ELECTS TO USE THE ALTERNATE MOUNTING METHOD OF THRU DRILLING THE MOUNTING HOLES FOR THE TRAFFIC BARRIER TERMINALS, TYPE 6, THE HOLES SHALL BE DRILLED USING A CORE DRILL. A HAMMER DRILL WILL NOT BE ALLOWED.

G.N. 668-SPL
ALL MARKERS USED TO DEFINE THE SURVEY CENTERLINE CONTROL POINTS (P.C.'S, P.I.'S, P.T.'S, P.O.T.'S) AND LAND SURVEY MONUMENTS (LAND SECTION OR SUB-SECTION CORNERS) THAT ARE WITHIN THE PROJECT LIMITS SHALL BE PRESERVED IN ACCORDANCE WITH THE PLANS, SPECIAL DETAILS, AND AS DIRECTED BY THE ENGINEER.

AN ILLINOIS PROFESSIONAL LAND SURVEYOR IS REQUIRED IN REGARDS TO LAND SURVEY MONUMENTS TO BE PRESERVED.

THE RESIDENT ENGINEER SHALL CONTACT THE COLES COUNTY ENGINEER PRIOR TO THE PRE-CONSTRUCTION CONFERENCE FOR INSTRUCTION AS TO SETTING OF TEMPORARY OR PERMANENT TIES FOR CENTERLINE ALIGNMENT CONTROL SURVEY MARKERS AND TO DETERMINE IF IT WILL BE NECESSARY FOR THE CONTRACTOR TO HIRE AN ILLINOIS LAND SURVEYOR.

G.N. -703A
SHORT TERM PAVEMENT MARKING SHALL BE APPLIED TO THE PAVEMENT AFTER ANY OF THE FOLLOWING: COLD MILLING AND/OR PLACING BITUMINOUS MATERIALS (PRIME COAT), LEVELING BINDER (MACHINE METHOD), BINDER AND SURFACE COURSES. SHORT TERM PAVEMENT MARKING PLACED ON THE SURFACE, SHALL COINCIDE WITH THE FINAL PAVEMENT STRIPING. SHORT TERM PAVEMENT MARKING PLACED PRIOR TO THE SURFACE SHALL COINCIDE WITH THE EXISTING PAVEMENT MARKINGS. USE 4 FEET PER 40 FEET (OR 10' PER STATION).

G.N. -781
RAISED REFLECTIVE PAVEMENT MARKERS SHALL BE PLACED IN ACCORDANCE WITH STANDARD 781001, AND THE DETAILS SHOWN IN THE PLANS. IF THERE IS ANY DISCREPANCY BETWEEN THE STANDARD AND THE DETAILS IN THE PLANS, THE DETAILS IN THE PLANS SHALL GOVERN. THE FINAL PAVEMENT MARKINGS SHALL BE IN PLACE PRIOR TO PLACING THE RAISED REFLECTIVE PAVEMENT MARKERS AND THE RAISED REFLECTIVE PAVEMENT MARKERS SHALL BE PLACED MIDWAY IN THE 30 FOOT (9 m) SPACE BETWEEN THE DASHED CENTERLINE STRIPES (WHEN APPLICABLE).

G.N. -1004.01
COARSE AGGREGATE GRADATION CA-10 MAY BE USED WHENEVER COARSE AGGREGATE CA-6 IS SPECIFIED IN THE STANDARD SPECIFICATIONS.

G.N. -1004.03
REVISE ARTICLE 1004.03 (c) NOTE 5/ OF THE STANDARD SPECIFICATIONS TO READ:
'5/ GRADATION CA-16 SHALL BE USED IN LIEU OF CA-13 WHEN THE SURFACE COURSE IS LESS THAN 1 3/4 INCHES IN THICKNESS. CA-13 OR CA-16 MAY BE USED WHEN THE SURFACE COURSE IS 1 3/4 INCHES OR MORE IN THICKNESS.'

G.N. -Z0038
AN ALUMINUM TABLET OF THE TYPE SHOWN ON STANDARD 667101 SHALL BE PLACED ON THE PROPOSED STRUCTURE AS DIRECTED BY THE ENGINEER. THE BENCH MARK ELEVATION WILL BE ESTABLISHED AND MARKED BY THE DEPARTMENT. THIS WORK WILL BE PAID FOR AT THE CONTRACT UNIT PRICE EACH FOR PERMANENT BENCH MARKS.

UNDISTRIBUTED QUANTITIES HAVE BEEN INCLUDED IN THE CONTRACT QUANTITIES TO REPAIR UNKNOWN FIELD TILES ENCOUNTERED DURING CONSTRUCTION. THESE QUANTITIES WILL BE USED AS NEEDED IN ACCORDANCE WITH THE FIELD TILE REPAIR DETAIL. UNUSED QUANTITIES WILL BE DELETED UPON COMPLETION OF THE CONTRACT.
THESE ITEMS INCLUDE:
PAVED DITCH (SPECIAL)
MISCELLANEOUS CONCRETE
STORM SEWER PROTECTED, CLASS A, VARIOUS SIZES
FIELD TILE JUNCTION VAULT, 2' DIA.
INSPECTION WELLS

INTERNET ACCESSIBILITY TO THE BITUMINOUS PLANT QUALITY CONTROL LAB WILL BE PROVIDED SO THAT BITUMINOUS PLANT REPORTS CAN BE E-MAILED TO THE DISTRICT HEADQUARTERS. THIS WORK SHALL BE INCLUDED IN THE COST OF ALL BITUMINOUS PAY ITEMS.

G.N. -406H
THE FOLLOWING MIXTURE REQUIREMENTS ARE APPLICABLE FOR THIS PROJECT:

LOCATION MIXTURE USE	INCIDENTAL	US 45 & CH 18 BIT SHLDR SPAVE >2 1/4" THICKNESS	US 45 & CH18 BIT SHOULDERS < 2 1/4"	CH 18 4" STAB. SUB-BASE	US 45 BIT BASE CSE	US 45 SURFACE
AC/PG	PG 64-22	PG 58-22	PG 58-22	PG 64-22	PG 64-22	PG 64-22
RAP % (MAX)	15%	30%	30%	30%	25%	15%
DESIGN AIR VOIDS	4.0% @ NDES = 50	2.0% @ NDES = 30	3.0% @ NDES = 30	4.0% @ NDES = 30	4.0% @ NDES = 70	4.0% @ NDES = 70
MIX COMP (GRADATION)	IL 9.5	B.A.M.	IL 9.5L	IL 19.0L	IL 19.0	IL 9.5
FRICION AGGREGATE	MIX C	N.A.	MIX C	N.A.	N.A.	MIX D

REVISIONS		ILLINOIS DEPARTMENT OF TRANSPORTATION
NAME	DATE	
		GENERAL NOTES

SCALE: VERT. HORIZ.
DATE 08/22/2005

DRAWN BY RLH
CHECKED BY MED

TUG PROJ. #131022-5
SHEET-W.D01
08/22/2005

F.A.S. RTE.	SECTION	COUNTY	TOTAL SHEETS	SHEET NO.
642	99-00124-01-PV	COLES	157	14
STA.		TO STA.		
FED. ROAD DIST. NO.		ILLINOIS	FED. AID PROJECT	

SUMMARY OF QUANTITIES

PAY LIMITS = 102+50 TO 141+25 C.H. 18 (BRIDGE & APPROACHES ONLY) **ICC ELIGIBLE**
 PAY LIMITS = 102+50 TO 141+25 C.H. 18 **ICC ELIGIBLE**
 PAY LIMITS = 100+00 TO 166+00 C.H. 18

ITEM NUMBER	ITEM	UNIT	TOTAL QUANTITY	X571-2A (1)	J000-2A	X571-2A (2)
20200100	EARTH EXCAVATION	CU YD	162453	141629	14934	5890
20400800	FURNISHED EXCAVATION	CU YD	91921	84782	3603	3536
20700400	POROUS GRANULAR EMBANKMENT (SPECIAL)	CU YD	362	362		
20800150	TRENCH BACKFILL	CU YD	163	154		9
21301052	EXPLORATION TRENCH 52" DEPTH	FOOT	5565	3420		2145
25000200	SEEDING, CLASS 2	ACRE	34.1	8.9	17.5	7.7
25000350	SEEDING, CLASS 7	ACRE	34.1	8.9	17.5	7.7
25000400	NITROGEN FERTILIZER NUTRIENT	POUND	3065	801	1575	689
25000500	PHOSPHORUS FERTILIZER NUTRIENT	POUND	3065	801	1575	689
25000600	POTASSIUM FERTILIZER NUTRIENT	POUND	3065	801	1575	689
25000700	AGRICULTURAL GROUND LIMESTONE	TON	68	17.8	35	15.2
25000750	MOWING	ACRE	34.1			34.1
25100115	MULCH, METHOD 2	ACRE	68.1	17.8	35	15.3
25100630	EROSION CONTROL BLANKET	SQ YD	19743	18728		1015
28000250	TEMPORARY EROSION CONTROL SEEDING	POUND	3290			3290
28000300	TEMPORARY DITCH CHECKS	EACH	64	11	41	12
28000400	PERIMETER EROSION BARRIER	FOOT	4314	2987	430	897
28000500	INLET AND PIPE PROTECTION	EACH	25	9	2	14
28100107	STONE RIPRAP, CLASS A4	SQ YD	18			18
28200200	FILTER FABRIC	SQ YD	18			18
XX006230	PROCESSING LIME MODIFIED SOILS 12"	SQ YD	29761	12128	6246	11387
XX006231	WATER	UNIT	149	61	31	57
30201500	LIME	TON	670	273	141	256
31101200	SUBBASE GRANULAR MATERIAL, TYPE B 4"	SQ YD	2502		2219	283
31200100	STABILIZED SUB-BASE 4"	SQ YD	29761	12128	6246	11387
35100100	AGGREGATE BASE COURSE, TYPE A	TON	137	18		119
40200800	AGGREGATE SURFACE COURSE, TYPE B	TON	154	154		
40600100	BITUMINOUS MATERIALS (PRIME COAT)	GALLON	1260		1260	
40600300	AGGREGATE (PRIME COAT)	TON	18		18	
40600980	BITUMINOUS SURFACE REMOVAL - BUTT JOINT	SQ YD	160		160	
40600990	TEMPORARY RAMP	SQ YD	112		112	
40800010	BITUMINOUS MATERIALS (PRIME COAT)	GALLON	133	93		40
40800040	INCIDENTAL BITUMINOUS SURFACING	TON	152	106		46
42000301	PORTLAND CEMENT CONCRETE PAVEMENT 8" (JOINTED)	SQ YD	27658	8896	7377	11385
42001165	BRIDGE APPROACH PAVEMENT	SQ YD	138	138		
42001300	PROTECTIVE COAT	SQ YD	28080	28080		
42001400	BRIDGE APPROACH PAVEMENT (SPECIAL)	SQ YD	141		141	
42001420	BRIDGE APPROACH PAVEMENT CONNECTOR (PCC)	SQ YD	55	55		
42300400	PORTLAND CEMENT CONCRETE DRIVEWAY PAVEMENT, 8 INCH	SQ YD	5527		5527	
44000100	PAVEMENT REMOVAL	SQ YD	10615	7327	1096	2192
44000200	DRIVEWAY PAVEMENT REMOVAL	SQ YD	4707		2719	1988
44000500	COMBINATION CURB AND GUTTER REMOVAL	FOOT	1458	155	331	972
44002500	GUTTER OUTLET REMOVAL	EACH	2	2		
44002805	ISLAND REMOVAL	SQ FT	415	415		
44003100	MEDIAN REMOVAL	SQ FT	992	992		
44004250	PAVED SHOULDER REMOVAL	SQ YD	130		130	
44004300	PAVEMENT BREAKING	SQ YD	2822	2822		
44100300	PAVEMENT REPLACEMENT (SPECIAL)	SQ YD	86	86		
44200089	PAVEMENT PATCHING, TYPE I, 8"	SQ YD	36	9		27
44200094	PAVEMENT PATCHING, TYPE II, 8"	SQ YD	15	15		
44300200	STRIP REFLECTIVE CRACK CONTROL TREATMENT	FOOT	2730		2730	
48101500	AGGREGATE SHOULDERS, TYPE B 6"	SQ YD	4564	387	2439	1738
48201000	BITUMINOUS SHOULDERS	TON	47		47	
48202600	BITUMINOUS SHOULDERS SUPERPAVE 8"	SQ YD	7947	5710	1676	561
48300300	PORTLAND CEMENT CONCRETE SHOULDERS 8"	SQ YD	142	142		
50104400	CONCRETE HEADWALL REMOVAL	EACH	2	2		
50105220	PIPE CULVERT REMOVAL	FOOT	1261	444		817
50200100	STRUCTURE EXCAVATION	CU YD	618	312		306
50300100	FLOOR DRAINS	EACH	8	4		4
50300225	CONCRETE STRUCTURES	CU YD	767	75	336	356
50300255	CONCRETE SUPERSTRUCTURES	CU YD	486.8	261		225.8
50300260	BRIDGE DECK GROOVING	SQ YD	1337	722		615

REVISIONS	
NAME	DATE

ILLINOIS DEPARTMENT OF TRANSPORTATION

SUMMARY OF QUANTITIES

SCALE: VERT. DRAWN BY RLH
 HORIZ. CHECKED BY MED
 DATE: 09/02/2005

TUG PROJ. #13157022-5
 ...SHEET #4 of 4
 09/02/2005

F.A.S. RTE.	SECTION	COUNTY	TOTAL SHEETS	SHEET NO.
642	99-00124-01-PV	COLES	157	15
STA.		TO STA.		
FED. ROAD DIST. NO.	ILLINOIS	FED. AID PROJECT		

SUMMARY OF QUANTITIES

PAY LIMITS = 141+25 C.H. 18
102+50 TO APPROACHES ONLY
(BRIDGE & APPROACHES ONLY)
ICC ELIGIBLE

PAY LIMITS = 141+25 C.H. 18
102+50 TO 141+25 C.H. 18
ICC ELIGIBLE

PAY LIMITS = 100+00 TO 102+50 C.H. 18
141+25 TO 166+00 C.H. 18
ICC ELIGIBLE

ITEM NUMBER	ITEM	UNIT	TOTAL QUANTITY	X571-2A	3000-2A	X571-2A
50300300	PROTECTIVE COAT	SQ YD	1672	903		769
50500105	FURNISHING AND ERECTING STRUCTURAL STEEL	L SUM	1	0.5		0.5
50500505	STUD SHEAR CONNECTORS	EACH	2400	1296		1104
50800105	REINFORCEMENT BARS	POUND	250	57		193
50800205	REINFORCEMENT BARS, EPOXY COATED	POUND	202620	107815		94805
51100100	SLOPE WALL, 4"	SQ YD	825	428		397
51201900	FURNISHING STEEL PILES HP 14X89	FOOT	2687	1451		1236
51202700	DRIVING STEEL PILES	FOOT	2687	1451		1236
51203900	TEST PILE, STEEL HP 14X89	EACH	2	2		
51500100	NAME PLATES	EACH	1	1		
54200430	PIPE CULVERTS, TYPE 1 RCCP 15"	FOOT	8		8	
54200433	PIPE CULVERTS, TYPE 1 RCCP 18"	FOOT	144		16	128
54200439	PIPE CULVERTS, TYPE 1 RCCP 24"	FOOT	296	296		
54200451	PIPE CULVERTS, TYPE 1 RCCP 36"	FOOT	80			80
54201291	PIPE CULVERTS, TYPE 2 RCCP 36"	FOOT	98	98		
54204861	PIPE CULVERTS, TYPE 7 RCCP 36"	FOOT	160	160		
54207171	PIPE CULVERTS, TYPE 1, REINFORCE CONCRETE - ELLIPTICAL, EQ RS 36"	FOOT	292	64	152	76
54207783	PIPE CULVERTS, TYPE 1, CORRUGATED STEEL OR ALUMINUM, EQ RS 18"	FOOT	43	43		
54207789	PIPE CULVERTS, TYPE 1, CORRUGATED STEEL OR ALUMINUM, EQ RS 24"	FOOT	283	88		195
54207801	PIPE CULVERTS, TYPE 1, CORRUGATED STEEL OR ALUMINUM, EQ RS 36"	FOOT	55			55
5421D012	PIPE CULVERTS, CLASS D, TYPE 1 12" (TEMPORARY)	FOOT	222	68		154
5421D024	PIPE CULVERTS, CLASS D, TYPE 1 24" (TEMPORARY)	FOOT	70	70		
54213657	PRECAST REINFORCED CONCRETE FLARED END SECTIONS 12"	EACH	1			1
54213660	PRECAST REINFORCED CONCRETE FLARED END SECTIONS 15"	EACH	1		1	
54213663	PRECAST REINFORCED CONCRETE FLARED END SECTIONS 18"	EACH	6		2	4
54213669	PRECAST REINFORCED CONCRETE FLARED END SECTIONS 24"	EACH	5	4		1
54213681	PRECAST REINFORCED CONCRETE FLARED END SECTIONS 36"	EACH	8	4		4
54214731	PRECAST REINFORCED CONCRETE FLARED END SECTIONS - ELL EQ RS 36"	EACH	8	2	4	2
54215547	METAL END SECTIONS 12"	EACH	17	17		
54215763	METAL END SECTIONS, EQUIVALENT ROUND-SIZE 18"	EACH	2	2		
54215769	METAL END SECTIONS, EQUIVALENT ROUND-SIZE 24"	EACH	12	4		8
54215781	METAL END SECTIONS, EQUIVALENT ROUND-SIZE 36"	EACH	2			2
550A0030	STORM SEWERS, CLASS A, TYPE 1 8"	FOOT	71		71	
550A0050	STORM SEWERS, CLASS A, TYPE 1 12"	FOOT	486	237	249	
550A0120	STORM SEWERS, CLASS A, TYPE 1 24"	FOOT	233	233		
550A0410	STORM SEWERS, CLASS A, TYPE 2 24"	FOOT	317	317		
550B0160	STORM SEWERS, CLASS B, TYPE 1 36"	FOOT	1144			1144
55100500	STORM SEWER REMOVAL 12"	FOOT	197	61	136	
60100945	PIPE DRAINS 12"	FOOT	1032	1032		
60218500	MANHOLES, TYPE A, 4' DIAMETER, TYPE 3 FRAME AND GRATE	EACH	1		1	
60221100	MANHOLES, TYPE A, 5'-DIAMETER, TYPE 1 FRAME, CLOSED LID	EACH	3	1		2
60221700	MANHOLES, TYPE A, 5'-DIAMETER, TYPE B GRATE	EACH	2	1		1
60223100	MANHOLES, TYPE A, SPECIAL, 5'-DIAMETER, TYPE 1 FRAME, CLOSED LID	EACH	1	1		
60235700	INLETS, TYPE A, TYPE 3 FRAME AND GRATE	EACH	2		2	
60500060	REMOVE INLETS	EACH	7	5	2	
60600095	CLASS SI CONCRETE (OUTLET)	CU YD	4		4	
60603500	COMBINATION CONCRETE CURB AND GUTTER, TYPE B-6.06	FOOT	11		11	
60603800	COMBINATION CONCRETE CURB AND GUTTER, TYPE B-6.12	FOOT	1044		1044	
60605000	COMBINATION CONCRETE CURB AND GUTTER, TYPE B-6.24	FOOT	453		453	
60605500	COMBINATION CONCRETE CURB AND GUTTER, TYPE B-6.24 (VWGF)	FOOT	18		18	
60614600	PAVED DITCH (SPECIAL)	FOOT	50			50
60618300	CONCRETE MEDIAN SURFACE, 4 INCH	SQ FT	89		89	
60900515	CONCRETE THRUST BLOCKS	EACH	18	18		
61000115	TYPE E INLET BOX, STANDARD 610001	EACH	14	14		
61000120	TYPE E INLET BOX, STANDARD 610001 (SPECIAL)	EACH	9	9		
61100605	MISCELLANEOUS CONCRETE	CU YD	16	16		
61101005	STORM SEWER PROTECTED, CLASS A, 4"	FOOT	120			120
61101007	STORM SEWER PROTECTED, CLASS A, 6"	FOOT	120			120
61101009	STORM SEWER PROTECTED, CLASS A, 8"	FOOT	120			120
61101011	STORM SEWER PROTECTED, CLASS A 10"	FOOT	120			120
61101013	STORM SEWER PROTECTED, CLASS A, 12"	FOOT	120			120

REVISIONS	
NAME	DATE

ILLINOIS DEPARTMENT OF TRANSPORTATION

SUMMARY OF QUANTITIES

SCALE: VERT. DRAWN BY RLH
 HORIZ. CHECKED BY MED
 DATE 09/02/2005

TUG PROJ. #13187022-5
 11/13/02
 12/22/2005

F.A.S. RTE.	SECTION	COUNTY	TOTAL SHEETS	SHEET NO.
642	99-00124-01-PV	COLES	157	16
STA.		TO STA.		
FED. ROAD DIST. NO.	ILLINOIS	FED. AID PROJECT		

SUMMARY OF QUANTITIES

PAY LIMITS = 141+25 C.H. 18
102+50 TO APPROACHES ONLY
(BRIDGE & APPROACHES ONLY)
ICC ELIGIBLE

PAY LIMITS = 141+25 C.H. 18
102+50 TO APPROACHES ONLY
ICC ELIGIBLE

PAY LIMITS = 102+50 C.H. 18
141+25 TO 166+00 C.H. 18
ICC ELIGIBLE

ITEM NUMBER	ITEM	UNIT	TOTAL QUANTITY	X571-2A	J000-2A	X571-2A
61101020	STORM SEWER PROTECTED, CLASS A, 18"	FOOT	120			120
61101026	STORM SEWER PROTECTED, CLASS A, 24"	FOOT	120			120
61133100	FIELD TILE JUNCTION VAULTS, 2' DIA.	EACH	8			8
63000000	STEEL PLATE BEAM GUARD RAIL, TYPE A	FOOT	3413	3413		
63100085	TRAFFIC BARRIER TERMINAL, TYPE 6	EACH	4	4		
63100169	TRAFFIC BARRIER TERMINAL, TYPE 1, SPECIAL (FLARED)	EACH	4	4		
63500105	DELINEATORS	EACH	32	28		4
66101120	BITUMINOUS SHOULDER CURB	FOOT	3459	3459		
66600105	FURNISHING AND ERECTING RIGHT-OF-WAY MARKERS	EACH	46	15	13	18
67000400	ENGINEER'S FIELD OFFICE, TYPE A	CAL MO	16	5	2	9
67000600	ENGINEER'S FIELD LABORATORY	CAL MO	16	5	2	9
67100100	MOBILIZATION	L SUM	1			1
70100460	TRAFFIC CONTROL AND PROTECTION, STANDARD 701306	L SUM	1		1	
70100500	TRAFFIC CONTROL AND PROTECTION, STANDARD 701326	L SUM	1		1	
70300100	SHORT-TERM PAVEMENT MARKING	FOOT	500		500	
70300220	TEMPORARY PAVEMENT MARKING-LINE 4"	FOOT	4925	425	4500	
70301000	WORK ZONE PAVEMENT MARKING REMOVAL	SQ FT	1808		1808	
70400100	TEMPORARY CONCRETE BARRIER	FOOT	165	165		
72000100	SIGN PANEL - TYPE 1	SQ FT	149	45	104	
72000200	SIGN PANEL - TYPE 2	SQ FT	67	26	41	
72800100	TELESCOPING STEEL SIGN SUPPORT	FOOT	550	129	421	
*78000100	THERMOPLASTIC PAVEMENT MARKING - LETTERS AND SYMBOLS	SQ FT	156		156	
*78000200	THERMOPLASTIC PAVEMENT MARKING - LINE 4"	FOOT	12791		12791	
*78000600	THERMOPLASTIC PAVEMENT MARKING - LINE 12"	FOOT	263		263	
*78001110	PAINT PAVEMENT MARKING - LINE 4"	FOOT	11755	4163	3496	4096
*78005100	EPOXY PAVEMENT MARKING - LETTERS AND SYMBOLS	SQ FT	437	312	125	
*78005110	EPOXY PAVEMENT MARKING - LINE 4"	FOOT	24030	15764	654	7612
*78005150	EPOXY PAVEMENT MARKING - LINE 12"	FOOT	1011	527	354	130
*78005180	EPOXY PAVEMENT MARKING - LINE 24"	FOOT	63		63	
*78100100	RAISED REFLECTIVE PAVEMENT MARKER	EACH	156		156	
*78200100	MONODIRECTIONAL PRISMATIC BARRIER REFLECTOR	EACH	8	8		
*78200300	PRISMATIC CURB REFLECTOR	EACH	6		6	
*78200410	GUARDRAIL MARKERS, TYPE A	EACH	15	15		
*78201000	TERMINAL MARKER -DIRECT APPLIED	EACH	4	4		
78300100	PAVEMENT MARKING REMOVAL	SQ FT	2515		2515	
78300200	RAISED REFLECTIVE PAVEMENT MARKER REMOVAL	EACH	156		156	
X0321100	GEOTEXTILE RETAINING WALL	SQ FT	804		804	
X3550600	BITUMINOUS BASE COURSE SUPERPAVE 9"	SQ YD	2219		2219	
X4066426	BITUMINOUS CONCRETE SURFACE COURSE, SUPERPAVE, MIX "D", N70	TON	771		771	
X6020073	INLETS, TYPE A, TYPE B GRATE, TEMPORARY	EACH	1			1
X7015005	CHANGEABLE MESSAGE SIGN	CAL DAY	14		14	
XX002909	CLASS SI CONCRETE	CU YD	2.3		2.3	
X0322024	TRENCH DRAIN	EACH	1		1	
XX006414	PORTLAND CEMENT CONCRETE BASE COURSE, 8" (SPECIAL)	SQ YD	86		86	
XZ193300	SURVEY MARKER, TYPE 1 (SPECIAL)	EACH	1		1	
Z0000990	AGGREGATE FOR TEMPORARY ACCESS	TON	150	150		
Z0002600	BAR SPLICERS	EACH	80	80		
Z0007601	BUILDING REMOVAL NO. 1	L SUM	1			1
Z0007602	BUILDING REMOVAL NO. 2	L SUM	1			1
Z0007603	BUILDING REMOVAL NO. 3	L SUM	1			1
Z0007604	BUILDING REMOVAL NO. 4	L SUM	1			1
Z0030900	INSPECTION WELLS	EACH	16	16		
Z0037300	PAVEMENT GROOVING (Approach Slabs)	SQ. YD.	279	279		
Z0038700	PERMANENT BENCH MARKS (At Bridges)	EACH	2	2		
Z0047300	PROTECTIVE SHIELD	SQ YD	473	255	218	
Z0048665	RR LIABILITY & PROTECTION INSURANCE	L SUM	1	1		
Z0049801	REMOVAL AND DISPOSAL OF FRIABLE ASBESTOS BUILDING NO. 1	L SUM	1			1
Z0049904	REMOVAL AND DISPOSAL OF NON-FRIABLE ASBESTOS BUILDING NO. 4	L SUM	1			1
XX004056	MECHANICALLY STABILIZED EARTH RETAINING WALL	SQ FT	17341		17341	
XX006411	US 45 DETOUR	L SUM	1		1	
XX006412	COARSE AGGREGATE EMBANKMENT (SPECIAL)	CU YD	3266	3266		
XX006413	GUARDRAIL AGGREGATE EROSION CONTROL	CU YD	243	243		

*SPECIALTY ITEMS

REVISIONS	
NAME	DATE

ILLINOIS DEPARTMENT OF TRANSPORTATION

SUMMARY OF QUANTITIES

SCALE: VERT. DRAWN BY RLH
 HORIZ. CHECKED BY MED
 DATE 09/02/2005

TUG PROJ #13107022-5
 SHEET-W.dgn
 09/02/2005

F.A.S. RTE.	SECTION	COUNTY	TOTAL SHEETS	SHEET NO.
642	99-00124-01-PV	COLES	157	17
STA.		TO STA.		
FED. ROAD DIST. NO.	ILLINOIS	FED. AID PROJECT		

CULVERT SCHEDULE

SIDE	STATION	REMARKS	RCCP, TYPE 1				RCCP, TYPE 2	RCCP, TYPE 7	CSCP, TYPE 1			TEMP. PIPE CULVERT CLASS D, TYPE 1		METAL END SECTION			PRC FLARED END SECTION					INLET, TYPE A, TYPE 8 GRATE, TEMP.	TRENCH BACKFILL	
			15"	18"	24"	36"	ELP. EQUIV. 36"	36"	36"	ARCH EQUIV. 18"	ARCH EQUIV. 24"	ARCH EQUIV. 36"	12"	24"	EQUIV. 18"	EQUIV. 24"	EQUIV. 36"	15"	18"	24"	36"			EQUIV. 36"
			LIN FT	LIN FT	LIN FT	LIN FT	LIN FT	LIN FT	LIN FT	LIN FT	LIN FT	LIN FT	LIN FT	LIN FT	EACH	EACH	EACH	EACH	EACH	EACH	EACH	EACH	CU. YD.	
LT	102+81	FIELD ENTRANCE									45					2								
RT	103+01	FIELD ENTRANCE								43					2									
	103+50	ACROSS ROAD					64														2			
LT	107+05	FIELD ENTRANCE								160						2								
	118+00	ACROSS ROAD																			2			
	120+78	ACROSS ROAD			128																			
	123+05	ACROSS ROAD			168																		7.5	
	125+00	ACROSS ROAD (TEMPORARY)											68										2.0	
	138+00	ACROSS ROAD (TEMPORARY)												70									23.0	
	138+00	ACROSS ROAD							75												1			
LT	138+00	OULET FROM MANHOLE						23													1			
LT	144+00	ACROSS ROAD (TEMPORARY)											30										0.7	
	148+00	ACROSS ROAD					64														1		3.7	
LT	148+00	TEMPORARY EXTENSION					12														1			
RT	149+48	COMMERCIAL ENTRANCE		56																	2			
LT	149+50	ACROSS ROAD (TEMPORARY)											24									1	0.9	
LT	150+63	FIELD ENTRANCE											53			2								
RT	152+64	COMMERCIAL ENTRANCE		72																				
LT	154+27	PRIVATE ENTRANCE											43											
LT	156+70	FIELD ENTRANCE											50											
LT	158+00	158+00 LT TO 159+00 LT												100									3.2	
RT	158+40	LOGAN STREET				80																		
LT	163+00	FIELD ENTRANCE											49			2								
RT	163+00	FIELD ENTRANCE												55							2			
JUGHANDLE																								
	104+98	ACROSS ROAD					56															2		
LT	114+26	DETENTION OUTLET		16																		2		
	115+85	ACROSS ROAD					96																	
MASTERFOODS, USA																								
LT	23+84	EXTEND CULVERT	8																					
TOTALS			8	144	296	80	292	98	160	43	283	55	222	70	2	12	2	1	6	4	6	8	1	41.0

GUARDRAIL MARKER SCHEDULE

LOCATION	GUARDRAIL MARKERS TYPE A	MONODIRECTIONAL PRISMATIC BARRIER REFLECTOR
	EACH	EACH
108+57, RT	1	
109+37, RT	1	
110+17, RT	1	
110+81, LT	1	
110+97, RT	1	
111+77, RT	1	
112+57, RT	1	
114+81, LT	1	
116+57, RT	1	
118+81, LT	1	
120+57, RT		1
122+81, LT		1
124+57, RT	1	
126+81, LT		1
128+57, RT	1	
130+81, LT		1
131+61, LT		1
132+41, LT		1
132+57, RT	1	
133+21, LT		1
134+01, LT		1
134+81, LT	1	
136+57, RT	1	
TOTALS	15	8

EXPLORATION TRENCH 52" DEPTH SCHEDULE

STATION TO STATION	LENGTH
	LIN FT
100+00 TO 120+45	2045
122+75 TO 135+50	1275
137+75 TO 151+65	1390
155+25 TO 157+45	220
159+65 TO 166+00	635
TOTAL	5565

DELINEATOR SCHEDULE

LOCATION	DELINEATOR
	EACH
100+95 LT & RT	2
102+20 - 109+35 LT & RT	24
@ 65" SPACING	
110+60 LT & RT	2
112+50 LT & RT	2
114+50 LT & RT	2
TOTAL	32

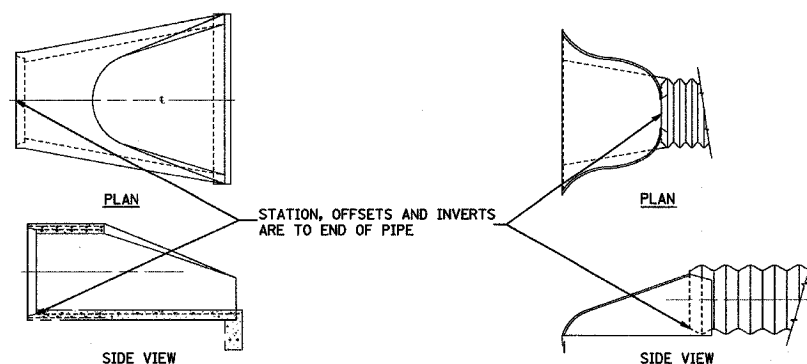

REVISIONS		ILLINOIS DEPARTMENT OF TRANSPORTATION
NAME	DATE	
		SCHEDULES

SCALE: VERT. _____
 HORIZ. _____
 DATE 04/08/2005

DRAWN BY RLH
 CHECKED BY MED

TUG PROJ. #181022-5
 \SHEET-W.dgn
 04/08/2005

DRAINAGE STRUCTURE SCHEDULE

F.A.S. RTE.	SECTION	COUNTY	TOTAL SHEETS	SHEET NO.
642	99-00124-01-PV	COLES	157	18
STA.		TO STA.		
FED. ROAD DIST. NO.	ILLINOIS	FED. AID PROJECT		

STRUCTURE	LOCATION	DESCRIPTION
COUNTY HIGHWAY 18		
1	108+70.00, 26.00' RT	TYPE E INLET BOX, STD. 610001
2	108+70.29, 63.21' RT	METAL END SECTION 12"
3	110+32.03, 26.00' LT	TYPE E INLET BOX, STD. 610001
4	110+32.09, 65.20' LT	METAL END SECTION 12"
5	111+07.16, 26.00' RT	TYPE E INLET BOX, STD. 610001
6	111+07.29, 67.79' RT	METAL END SECTION 12"
7	112+00.89, 73.36' LT	METAL END SECTION 12"
8	112+00.97, 25.07' LT	TYPE E INLET BOX, STD. 610001
9	114+01.04, 72.29' LT	METAL END SECTION 12"
10	114+01.18, 21.23' LT	TYPE E INLET BOX, STD. 610001
11	114+06.64, 24.24' RT	TYPE E INLET BOX, STD. 610001
12	114+07.94, 69.91' RT	METAL END SECTION 12"
13	116+94.87, 75.84' LT	METAL END SECTION 12"
14	116+95.06, 20.00' LT	TYPE E INLET BOX, STD. 610001
15	117+06.05, 20.03' RT	TYPE E INLET BOX, STD. 610001
16	117+06.18, 75.90' RT	METAL END SECTION 12"
17	119+81.00, 20.00' RT	TYPE E INLET BOX, STD. 610001
18	119+81.00, 82.37' RT	METAL END SECTION 12"
19	119+95.80, 20.00' LT	TYPE E INLET BOX, STD. 610001
20	119+95.80, 84.49' LT	METAL END SECTION 12"
21	123+77.29, 84.05' RT	METAL END SECTION 12"
22	123+77.46, 20.00' RT	TYPE E INLET BOX, STD. 610001
23	123+90.67, 20.00' LT	TYPE E INLET BOX, STD. 610001 (SPECIAL)
24	124+50.00, 20.00' LT	TYPE E INLET BOX, STD. 610001 (SPECIAL)
25	124+77.47, 20.00' RT	TYPE E INLET BOX, STD. 610001 (SPECIAL)
26	124+77.10, 86.91' RT	METAL END SECTION 12"
27	127+41.07, 20.00' LT	TYPE E INLET BOX, STD. 610001 (SPECIAL)
28	127+52.47, 20.00' RT	TYPE E INLET BOX, STD. 610001 (SPECIAL)
29	127+52.40, 75.02' RT	METAL END SECTION 12"
30	130+41.00, 25.40' LT	TYPE E INLET BOX, STD. 610001 (SPECIAL)
31	130+52.15, 25.56' RT	TYPE E INLET BOX, STD. 610001 (SPECIAL)
32	130+52.09, 74.02' RT	METAL END SECTION 12"
33	133+00.00, 44.50' LT	MANHOLE TYPE A, 5' DIAMETER, TYPE 8 GRATE
34	133+01.34, 97.78' LT	PRC FLARED END SECTION 24"
35	133+41.00, 26.00' LT	TYPE E INLET BOX, STD. 610001 (SPECIAL)
36	133+51.06, 26.00' RT	TYPE E INLET BOX, STD. 610001 (SPECIAL)
37	133+50.99, 62.00' RT	METAL END SECTION 12"
38	134+82.65, 26.00' LT	TYPE E INLET BOX, STD. 610001
39	134+82.69, 36.76' LT	MANHOLE TYPE A, 5' DIAMETER, TYPE 1 FRAME CL
40	135+02.90, 26.00' RT	TYPE E INLET BOX, STD. 610001
41	135+02.90, 62.03' RT	METAL END SECTION 12"
42	136+77.90, 26.00' RT	TYPE E INLET BOX, STD. 610001
43	136+77.90, 59.00' RT	METAL END SECTION 12"
44	138+00.00, 31.20' LT	MANHOLE TYPE A, SPECIAL, 5' DIAMETER, TYPE 1 FRAME CL
45	143+45.91, 47.48' RT	MANHOLE TYPE A, 5' DIAMETER, TYPE 8 GRATE
46	144+95.91, 47.48' RT	PRC FLARED END SECTION 36"
MASTERFOODS TRUCK ENTRANCE		
47	22+11.18, 24.00' LT	INLET TYPE A, TYPE 3 FRAME & GRATE
48	22+98.03, 77.49' LT	TRENCH DRAIN
49	23+34.04, 27.18' LT	INLET TYPE A, TYPE 3 FRAME & GRATE
50	23+53.77, 35.21' RT	MANHOLE TYPE A, 4' DIAMETER, TYPE 3 FRAME & GRATE
51	23+82.32, 77.85' RT	PRC FLARED END SECTION 36"
DRAINAGE EASMENT		
52	24+47.50, 0.00' RT	MANHOLE TYPE A, 5' DIAMETER, TYPE 1 FRAME CL
53	28+47.50, 0.00' RT	MANHOLE TYPE A, 5' DIAMETER, TYPE 1 FRAME CL
54	30+55.24, 0.00' RT	PRC FLARED END SECTION 36"

STORM SEWER SCHEDULE

FROM STRUCTURE	TO STRUCTURE	TRENCH BACKFILL CU. YD.	PIPE DRAIN 12"	STORM SEWER (RCCP) CLASS A, TYPE 1			STORM SEWER (RCCP) CL A, TY 2		CL B, TY 1
				8"	12"	24"	24"	36"	
1	2		36						
3	4		44						
5	6		44						
8	7		52						
10	9		58						
11	12		54						
14	13		66						
15	16		66						
17	18		74						
19	20		77						
22	21		81						
23	24				59				
24	25				44				
25	26		78						
27	28				37				
28	29		66						
30	31	5.4			49				
31	32		52						
34	33					48			
33	39					178			
35	36	6.4			48				
36	37		45						
38	39		9						
40	41		41						
39	44	49.4					312		
42	43		38						
47	50	41.3			138				
48	49	0.7		71					
49	50	9.6			63				
50	51	0.3			48				
46	45						148		
45	52						395		
52	53						395		
53	54						206		
		113.1	981	71	486	226	312	1144	

REVISIONS	
NAME	DATE

ILLINOIS DEPARTMENT OF TRANSPORTATION

SCHEDULES

SCALE: VERT. DATE 04/08/2005

DRAWN BY RLH CHECKED BY MED

TUG PROJ. #13191022-5
...SHEET-W.dgn
04/08/2005

F.A.S. RTE.	SECTION	COUNTY	TOTAL SHEETS	SHEET NO.
642	99-00124-01-PV	COLES	157	19
STA.		TO STA.		
FED. ROAD DIST. NO.	ILLINOIS	FED. AID PROJECT		

EARTHWORK SCHEDULE

STA. TO STA.	EARTH EXCAVATION CU. YD.	EARTH EXCAVATION ADJUSTED FOR SHINKAGE 25% CU. YD.	EMBANKMENT CU. YD.	FURNISHED EXCAVATION OR WASTE (-) CU. YD.	COARSE AGGREGATE EMBANKMENT, SPECIAL CU. YD.	SEEDING CLASS 2 ACRE	SEEDING CLASS 7 ACRE	NITROGEN FERTILIZER NUTRIENT POUND	PHOSPHORUS FERTILIZER NUTRIENT POUND	POTASSIUM FERTILIZER NUTRIENT POUND	AGRICULTURAL GROUND LIMESTONE TON	MOWING ACRE	MULCH METHOD 2 ACRE
COUNTY HIGHWAY 18													
100+00.00 TO 111+00.00	1642	1231	12767	11536		2.03	2.03	182	182	182	4.05	2.03	4.05
111+00.00 TO 120+29.00	291	218	90967	90749		2.76	2.76	249	249	249	5.53	2.76	5.53
123+45.50 TO 126+00.00	16	12	35877	35865		1.40	1.40	126	126	126	2.80	1.40	2.80
126+00.00 TO 141+00.00	5070	3803	60216	56413	3266	4.03	4.03	363	363	363	8.06	4.03	8.06
141+00.00 TO 156+00.00	3461	2596	3233	637		2.88	2.88	259	259	259	5.75	2.88	5.75
156+00.00 TO 166+00.00	2420	1815	3250	1435		1.81	1.81	163	163	163	3.63	1.81	3.63
JUGHANDLE													
100+30.00 TO 106+00.00	917	688	1943	1255		0.72	0.72	65	65	65	1.45	0.72	1.45
106+00.00 TO 116+58.21	8432	6324	1479	-4845		1.66	1.66	149	149	149	3.32	1.66	3.32
US ROUTE 45													
97+50.00 TO 102+50.00	329	247	48	-199		0.27	0.27	24	24	24	0.54	0.27	0.54
102+50.00 TO 117+50.00	4188	3141	1285	-1856		1.90	1.90	171	171	171	3.79	1.90	3.79
117+50.00 TO 127+25.00	889	667	209	-457		0.56	0.56	51	51	51	1.12	0.56	1.12
MASTERFOODS USA ENTRANCE													
	179	134	2482	2348		0.38	0.38	34	34	34	0.76	0.38	0.76
JUGHANDLE INFIELD													
	134611	100958	1	-100957		12.76	12.76	1149	1149	1149	25.53	12.76	25.53
DRAINAGE EASEMENT													
	8	6	3	-3		0.90	0.90	81	81	81	1.79	0.90	1.79
PROJECT TOTAL													
	162453	121840	213761	91921	3266	34.06	34.06	3065	3065	3065	68.12	34.06	68.12

REVISIONS	
NAME	DATE

ILLINOIS DEPARTMENT OF TRANSPORTATION

EARTHWORK SCHEDULE

SCALE: VERT.
HORIZ.
DATE 09/02/2005

DRAWN BY SJF
CHECKED BY MED

TUC PROJ #118102-5
SHEET # 19 OF 19
09/02/2005

F.A.S. RTE.	SECTION	COUNTY	TOTAL SHEETS	SHEET NO.
642	99-00124-01-PV	COLES	157	20
STA.		TO STA.		
FED. ROAD DIST. NO.	ILLINOIS	FED. AID PROJECT		

PAVING SCHEDULE

STA. TO STA.	PCC PAVEMENT 8" (JOINTED) SQ. YD.	BRIDGE APPROACH PAVEMENT SQ. YD.	BRIDGE APPROACH PAVEMENT (SPECIAL) SQ. YD.	PROTECTIVE COAT SQ. YD.	BIT. CONCRETE SURFACE COURSE SUPERPAVE, MIX D TON	BITUMINOUS SHOULDERS SUPERPAVE, 8" SQ. YD.	BITUMINOUS SHOULDERS TON	AGGREGATE SHOULDERS, TYPE B, 6" SQ. YD.	STABILIZED SUBBASE, 4" SQ. YD.
COUNTY HIGHWAY 18									
100+00.00 TO 111+00.00	4561.0			4575.8		918.9		488.3	4889.2
111+00.00 TO 120+29.00	2784.7	138		2989.9		1598.4			3085.4
123+45.50 TO 126+00.00	598.6		141	755.5		205.0			674.8
126+00.00 TO 141+00.00	6047.0			6091.4		1343.4		232.9	6547.0
141+00.00 TO 156+00.00	4129.0			4129.0		831.7		841.9	4629.0
156+00.00 TO 166+00.00	3016.0			3016.0		612.2		573.0	3316.2
JUGHANDLE									
100+30.00 TO 106+00.00	1948.0			1948.0		334.2		327.0	2139.8
106+00.00 TO 116+58.21	3865.0			3865.0		634.4		626.4	4240.5
US ROUTE 45									
97+50.00 TO 102+50.00					35.8	90.8		90.7	
102+50.00 TO 117+50.00					517.1	936.8		942.1	
117+50.00 TO 127+25.00					218.4	441.6	47	441.7	
LOGAN STREET	709.0			709.0					772.7
PROJECT TOTAL	27658.3	138	141	28079.6	771.3	7947.4	47	4564.0	30294.6

STA. TO STA.	LIME MODIFIED SOILS, 12" SQ. YD.	LIME TON	WATER UNIT	BITUMINOUS CONCRETE BASE COURSE SUPERPAVE, 9" SQ. YD.	SUBBASE GRANULAR MATERIAL TYPE B, 4" SQ. YD.	STRIP REFLECTIVE CRACK CONTROL LIN. FT.	PCC SHOULDERS, 8" SQ. YD.	BITUMINOUS MATERIALS (PRIME COAT) GALLON	AGGREGATE (PRIME COAT) TON
COUNTY HIGHWAY 18									
100+00.00 TO 111+00.00	4889.2	110.0	24.4				14.8	45.9	
111+00.00 TO 120+29.00	3085.4	69.4	15.4				67.2	79.9	
123+45.50 TO 126+00.00	674.8	15.2	3.4				15.9	10.3	
126+00.00 TO 141+00.00	6547.0	147.3	32.7				44.4	67.2	
141+00.00 TO 156+00.00	4629.0	104.2	23.1					41.6	
156+00.00 TO 166+00.00	3316.2	74.6	16.6					30.6	
JUGHANDLE									
100+30.00 TO 106+00.00	2139.8	48.1	10.7					16.7	
106+00.00 TO 116+58.21	4240.5	95.4	21.2					31.7	
US ROUTE 45									
97+50.00 TO 102+50.00				63.0	93.2	272		44.0	0.7
102+50.00 TO 117+50.00				2155.9	2408.8	2458		554.6	8.0
117+50.00 TO 127+25.00								337.7	5.2
LOGAN STREET	772.7	17.4	3.9						
PROJECT TOTAL	30294.6	681.6	151.5	2218.9	2502.0	2730	142.3	1260.2	13.9

REVISIONS	
NAME	DATE

ILLINOIS DEPARTMENT OF TRANSPORTATION

PAVING SCHEDULE

SCALE: VERT.
HORIZ.
DATE 04/08/2005

DRAWN BY SJF
CHECKED BY MED

TUG PROJ #1917022-5
-L-PAVING SCHEDULE-W.dgn
04/08/2005

F.A.S. RTE.	SECTION	COUNTY	TOTAL SHEETS	SHEET NO.
642	*	COLES	157	21
STA. 100+00.00		TO STA. 326+00.00		
FED. ROAD DIST. NO.		ILLINOIS FED. AID PROJECT		
99-00124-01-PV				

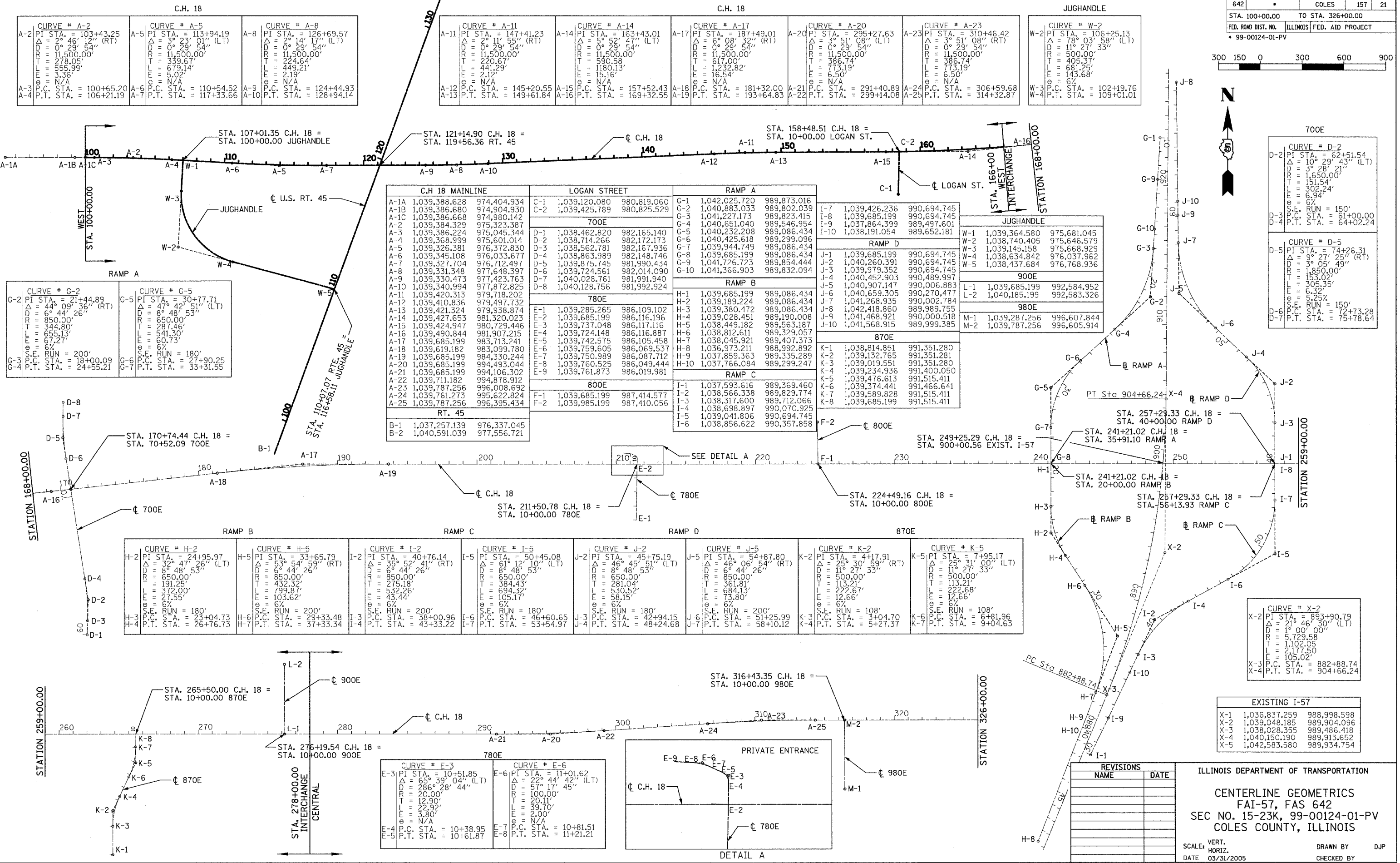
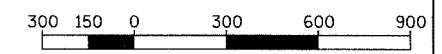

C.H. 18		
CURVE # A-2 PI STA. = 103+43.25 Δ = 6° 46' 12" (RT) D = 11,500.00' R = 278.05' T = 555.99' L = 3.36' E = N/A	CURVE # A-5 PI STA. = 113+94.19 Δ = 3° 23' 01" (LT) D = 11,500.00' R = 339.67' T = 679.14' L = 5.02' E = N/A	CURVE # A-8 PI STA. = 126+69.57 Δ = 2° 14' 17" (LT) D = 11,500.00' R = 224.64' T = 449.21' L = 2.19' E = N/A
A-2 P.C. STA. = 100+65.20 A-3 P.T. STA. = 106+21.19	A-5 P.C. STA. = 110+54.52 A-6 P.T. STA. = 117+33.66	A-8 P.C. STA. = 124+44.93 A-10 P.T. STA. = 128+94.14

C.H. 18			JUGHANDLE		
CURVE # A-11 PI STA. = 147+41.23 Δ = 2° 11' 55" (RT) D = 11,500.00' R = 220.67' T = 441.29' L = 2.12' E = N/A	CURVE # A-14 PI STA. = 163+43.01 Δ = 5° 52' 47" (LT) D = 11,500.00' R = 590.58' T = 1180.13' L = 15.16' E = N/A	CURVE # A-17 PI STA. = 187+49.01 Δ = 6° 08' 32" (RT) D = 11,500.00' R = 617.00' T = 1,232.82' L = 16.54' E = N/A	CURVE # A-20 PI STA. = 295+27.63 Δ = 3° 51' 08" (LT) D = 11,500.00' R = 386.74' T = 773.19' L = 6.50' E = N/A	CURVE # A-23 PI STA. = 310+46.42 Δ = 3° 51' 08" (RT) D = 11,500.00' R = 386.74' T = 773.19' L = 6.50' E = N/A	CURVE # W-2 PI STA. = 106+25.13 Δ = 78° 03' 58" (LT) D = 11° 27' 33" (LT) R = 500.00' T = 405.37' L = 681.25' E = 143.68' E = 67' S.E. RUN = 102+19.76 P.C. STA. = 102+19.76 P.T. STA. = 109+01.01
A-11 P.C. STA. = 145+20.55 A-12 P.T. STA. = 149+61.84	A-14 P.C. STA. = 157+52.43 A-15 P.T. STA. = 169+32.55	A-17 P.C. STA. = 181+32.00 A-19 P.T. STA. = 193+64.83	A-20 P.C. STA. = 291+40.89 A-22 P.T. STA. = 299+14.08	A-23 P.C. STA. = 306+59.68 A-25 P.T. STA. = 314+32.87	

RAMP A		RAMP D	
CURVE # G-2 PI STA. = 21+44.89 Δ = 44° 09' 36" (RT) D = 850.00' R = 344.80' T = 655.13' L = 67.27' E = 67' S.E. RUN = 200' P.C. STA. = 18+00.09 P.T. STA. = 24+55.21	CURVE # G-5 PI STA. = 30+77.71 Δ = 47° 42' 51" (LT) D = 850.00' R = 287.46' T = 541.30' L = 60.73' E = 67' S.E. RUN = 180' P.C. STA. = 27+90.25 P.T. STA. = 33+31.55	CURVE # J-1 PI STA. = 1039.685.199 Δ = 1040.260.391 Δ = 1039.979.352 Δ = 1040.452.903 Δ = 1040.907.147 Δ = 1040.659.305 Δ = 1041.268.935 Δ = 1042.418.860 Δ = 1041.468.921 Δ = 1041.568.915	CURVE # J-2 PI STA. = 990.694.745 Δ = 990.694.745 Δ = 990.694.745 Δ = 990.489.997 Δ = 990.006.883 Δ = 990.270.477 Δ = 990.002.784 Δ = 990.989.755 Δ = 990.000.518 Δ = 990.999.385

C.H. 18 MAINLINE		LOGAN STREET		RAMP A		RAMP D		RAMP B		RAMP C		RAMP D		870E			
A-1A	1,039,388.628	974,404.934	C-1	1,039,120.080	980,819.060	G-1	1,042,025.720	989,873.016	H-1	1,039,685.199	989,086.434	I-1	1,037,593.616	989,369.460	K-1	1,038,814.851	991,351.280
A-1B	1,039,386.680	974,904.930	C-2	1,039,425.789	980,825.529	G-2	1,040,883.033	989,802.039	H-2	1,039,189.224	989,086.434	I-2	1,038,566.358	989,829.774	K-2	1,039,132.765	991,351.281
A-1C	1,039,386.668	974,980.142	700E		G-3	1,041,227.173	989,823.415	H-3	1,039,380.472	989,086.434	I-3	1,038,317.600	989,712.066	K-3	1,039,019.551	991,351.280	
A-2	1,039,384.329	975,323.387	D-1	1,038,462.820	982,165.140	G-4	1,040,651.040	989,546.954	H-4	1,039,028.451	989,100.008	I-4	1,038,698.897	990,070.925	K-4	1,039,234.936	991,400.050
A-3	1,039,386.224	975,045.344	D-2	1,038,714.266	982,172.173	G-5	1,040,232.208	989,086.434	H-5	1,038,449.182	989,563.187	I-5	1,039,041.806	990,694.745	K-5	1,039,476.613	991,515.411
A-4	1,039,368.999	975,601.014	D-3	1,038,562.781	982,167.936	G-6	1,040,425.618	989,299.096	H-6	1,038,812.611	989,329.057	I-6	1,038,589.828	991,515.411	EXISTING I-57		
A-5	1,039,326.381	976,372.830	D-4	1,038,863.989	982,148.746	G-7	1,039,944.749	989,086.434	H-7	1,038,045.921	989,407.373	X-1	1,036,837.259	988,998.598			
A-6	1,039,345.108	976,033.677	D-5	1,039,875.745	981,990.434	G-8	1,039,685.199	990,694.745	H-8	1,036,973.211	988,992.892	X-2	1,039,048.185	989,904.096			
A-7	1,039,327.704	976,712.497	D-6	1,039,724.561	982,014.090	G-9	1,041,726.723	989,854.444	H-9	1,037,859.363	989,335.289	X-3	1,038,028.355	989,486.418			
A-8	1,039,331.348	977,648.397	D-7	1,040,028.761	981,991.940	G-10	1,041,366.903	989,832.094	H-10	1,037,766.084	989,299.247	X-4	1,040,150.190	989,913.652			
A-9	1,039,330.473	977,423.763	D-8	1,040,128.756	981,992.924	RAMP B		K-6	1,039,374.441	991,466.641	X-5	1,042,583.580	989,934.754				
A-10	1,039,340.994	977,872.825	A-11	1,039,420.313	979,718.202	RAMP C		K-7	1,039,589.828	991,515.411							
A-11	1,039,410.836	979,497.732	A-12	1,039,421.324	979,938.874	RAMP D											
A-12	1,039,421.324	979,938.874	A-13	1,039,427.653	981,320.023												
A-13	1,039,427.653	981,320.023	A-14	1,039,424.947	980,729.446												
A-14	1,039,424.947	980,729.446	A-15	1,039,490.844	981,907.215												
A-15	1,039,490.844	981,907.215	A-16	1,039,685.199	983,713.241												
A-16	1,039,685.199	983,713.241	A-17	1,039,619.182	983,099.780												
A-17	1,039,619.182	983,099.780	A-18	1,039,685.199	984,330.244												
A-18	1,039,685.199	984,330.244	A-19	1,039,685.199	994,493.044												
A-19	1,039,685.199	994,493.044	A-20	1,039,711.182	994,878.912												
A-20	1,039,711.182	994,878.912	A-21	1,039,787.256	996,008.692												
A-21	1,039,787.256	996,008.692	A-22	1,039,761.273	995,622.824												
A-22	1,039,761.273	995,622.824	A-23	1,039,985.199	987,414.577												
A-23	1,039,985.199	987,414.577	A-24	1,039,985.199	987,410.056												
A-24	1,039,985.199	987,410.056	RT. 45														
A-25	1,037,257.139	976,337.045	B-1	1,037,257.139	976,337.045												
A-26	1,040,591.039	977,556.721	B-2	1,040,591.039	977,556.721												

LAYOUT: DJP 11/23/03
 DRAWN: DJP 11/23/03
 REVIEWED:
 03/31/2005
 P:\CIVIL\57PH2\c-ccc\c-ccc.dwg

REVISIONS	
NAME	DATE

ILLINOIS DEPARTMENT OF TRANSPORTATION
 CENTERLINE GEOMETRICS
 FAI-57, FAS 642
 SEC NO. 15-23K, 99-00124-01-PV
 COLES COUNTY, ILLINOIS

SCALE: VERT. DRAWN BY DJP
 HORIZ. CHECKED BY

DATE: 03/31/2005

F.A. RTE.	SECTION	COUNTY	TOTAL SHEETS	SHEET NO.
642		COLES	157	22
STA. 326+00.00		TO STA. 637+00.00		
FED. ROAD DIST. NO.		ILLINOIS FED. AID PROJECT		
* 99-00124-01-PV				

CURVE # V-2		CURVE # V-5	
V-2	PI STA. = 75+00.25 Δ = 6° 15' 57" (LT) D = 1° 58' 00" R = 2,913.49' T = 159.47' L = 318.62' E = 4.36' e = N/A	V-5	PI STA. = 79+27.45 Δ = 5° 58' 53" (RT) D = 1° 45' 00" R = 3,274.17' T = 171.06' L = 341.82' E = 4.47' e = N/A
V-3	P.C. STA. = 73+40.79	V-6	P.T. STA. = 77+56.39
V-4	P.T. STA. = 76+59.40	V-7	P.C. STA. = 80+98.20

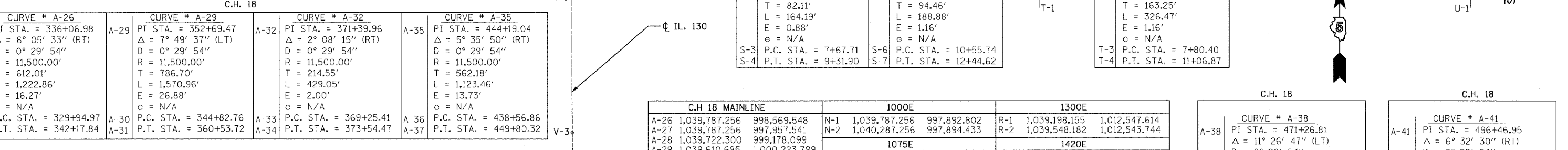
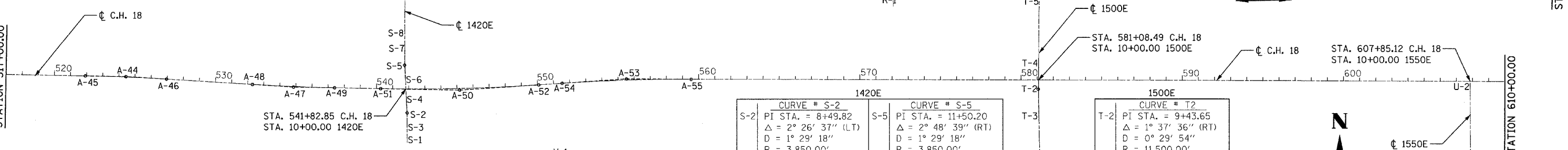
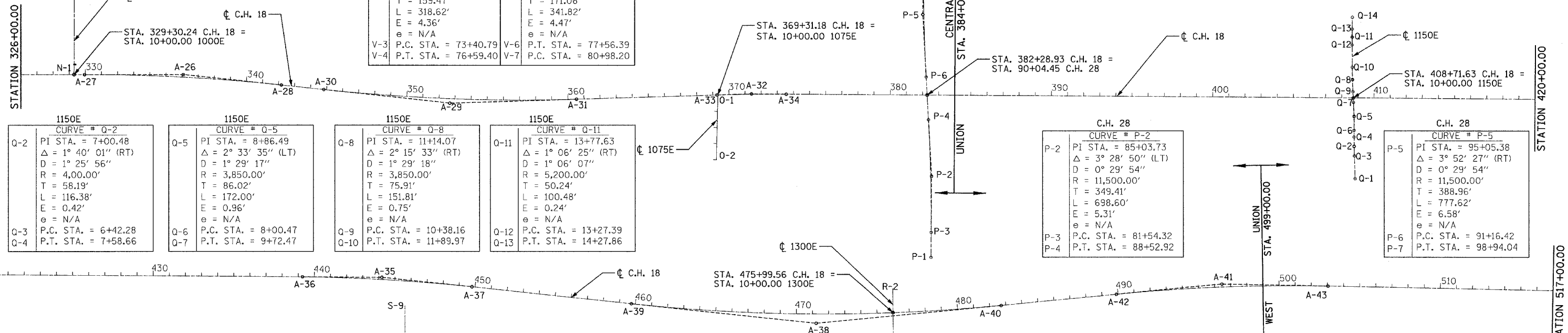

CURVE # A-26		CURVE # A-29		CURVE # A-32		CURVE # A-35	
A-26	PI STA. = 336+06.98 Δ = 6° 05' 33" (RT) D = 0° 29' 54" R = 11,500.00' T = 612.01' L = 1,222.86' E = 16.27' e = N/A	A-29	PI STA. = 352+69.47 Δ = 7° 49' 37" (LT) D = 0° 29' 54" R = 11,500.00' T = 786.70' L = 1,570.96' E = 26.88' e = N/A	A-32	PI STA. = 371+39.96 Δ = 2° 08' 15" (RT) D = 0° 29' 54" R = 11,500.00' T = 214.55' L = 429.05' E = 2.00' e = N/A	A-35	PI STA. = 444+19.04 Δ = 5° 35' 50" (RT) D = 0° 29' 54" R = 11,500.00' T = 562.18' L = 1,123.46' E = 13.73' e = N/A
A-27	P.C. STA. = 329+94.97	A-30	P.C. STA. = 344+82.76	A-33	P.C. STA. = 369+25.41	A-36	P.C. STA. = 438+56.86
A-28	P.T. STA. = 342+17.84	A-31	P.T. STA. = 360+53.72	A-34	P.T. STA. = 373+54.47	A-37	P.T. STA. = 449+80.32

CURVE # A-44		CURVE # A-47		CURVE # A-50		CURVE # A-53	
A-44	PI STA. = 524+43.33 Δ = 2° 30' 35" (RT) D = 0° 29' 54" R = 11,500.00' T = 251.90' L = 503.73' E = 2.76' e = N/A	A-47	PI STA. = 534+84.82 Δ = 2° 32' 33" (LT) D = 0° 29' 54" R = 11,500.00' T = 255.19' L = 510.29' E = 2.83' e = N/A	A-50	PI STA. = 545+16.50 Δ = 4° 53' 23" (LT) D = 0° 29' 54" R = 11,500.00' T = 491.01' L = 981.41' E = 10.48' e = N/A	A-53	PI STA. = 555+53.43 Δ = 3° 59' 26" (RT) D = 0° 29' 54" R = 11,500.00' T = 400.65' L = 800.97' E = 6.98' e = N/A
A-45	P.C. STA. = 521+91.43	A-48	P.C. STA. = 532+29.63	A-51	P.C. STA. = 540+25.50	A-54	P.C. STA. = 551+52.78
A-46	P.T. STA. = 526+95.15	A-49	P.T. STA. = 537+39.92	A-52	P.T. STA. = 550+06.91	A-55	P.T. STA. = 559+53.75

CURVE # S-2		CURVE # S-5	
S-2	PI STA. = 8+49.82 Δ = 2° 26' 37" (LT) D = 1° 29' 18" R = 3,850.00' T = 82.11' L = 164.19' E = 0.88' e = N/A	S-5	PI STA. = 11+50.20 Δ = 2° 48' 39" (RT) D = 1° 29' 18" R = 3,850.00' T = 94.46' L = 188.88' E = 1.16' e = N/A
S-3	P.C. STA. = 7+67.71	S-6	P.C. STA. = 10+55.74
S-4	P.T. STA. = 9+31.90	S-7	P.T. STA. = 12+44.62

C.H. 18 MAINLINE		1000E		1300E		
A-26	1,039,787.256	998,569.548	N-1	1,039,787.256	997,892.802	
A-27	1,039,787.256	997,957.541	N-2	1,040,287.256	997,894.433	
A-28	1,039,722.300	999,178.099	1075E		1420E	
A-29	1,039,610.685	1,000,223.789	O-1	1,039,661.049	1,001,887.193	
A-30	1,039,694.182	999,441.530	O-2	1,039,261.153	1,001,878.344	
A-31	1,039,634.494	1,001,010.131	C.H. 28		1500E	
A-32	1,039,667.369	1,002,095.877	P-1	1,038,655.780	1,003,208.430	
A-33	1,039,660.876	1,001,881.425	P-2	1,039,159.499	1,003,211.868	
A-34	1,039,665.859	1,002,310.422	P-3	1,038,810.099	1,003,209.483	
A-35	1,039,616.128	1,009,374.818	P-4	1,039,508.399	1,003,193.036	
A-36	1,039,620.085	1,008,812.657	P-5	1,040,159.905	1,003,157.871	
A-37	1,039,557.358	1,009,933.912	P-6	1,039,771.512	1,003,178.835	
A-38	1,039,332.965	1,012,068.638	P-7	1,040,548.827	1,003,163.198	
A-39	1,039,453.452	1,010,922.403	P-8	1,040,671.176	1,003,164.874	
A-40	1,039,442.344	1,013,215.986	1150E		1550E	
A-41	1,039,572.859	1,014,585.033	Q-1	1,039,142.130	1,005,839.110	
A-42	1,039,510.489	1,013,930.794	Q-2	1,039,341.661	1,005,833.011	
A-43	1,039,560.289	1,015,242.118	Q-3	1,039,283.494	1,005,834.789	
A-44	1,039,519.348	1,017,382.334	Q-4	1,039,399.855	1,005,832.926	
A-45	1,039,524.166	1,017,130.476	Q-5	1,039,527.678	1,005,832.739	
A-46	1,039,503.506	1,017,633.739	Q-6	1,039,441.663	1,005,832.865	
A-47	1,039,453.846	1,018,421.838	Q-7	1,039,613.602	1,005,828.772	
A-48	1,039,469.894	1,018,167.156	Q-8	1,039,755.051	1,005,822.241	
A-49	1,039,449.111	1,018,676.981	Q-9	1,039,679.219	1,005,825.742	
A-50	1,039,434.701	1,019,453.432	Q-10	1,039,830.962	1,005,821.732	
A-51	1,039,443.812	1,018,962.511	Q-11	1,040,018.617	1,005,820.473	
A-52	1,039,467.468	1,019,943.343	Q-12	1,039,968.379	1,005,820.810	
A-53	1,039,503.939	1,020,488.638	Q-13	1,040,068.852	1,005,821.107	
A-54	1,039,477.202	1,020,088.882	Q-14	1,040,141.250	1,005,822.020	
A-55	1,039,502.791	1,020,889.285	1500E		1550E	
A-56	1,039,481.451	1,028,334.767	U-1	1,038,986.210	1,025,723.290	
A-57	1,039,480.664	1,028,635.502	U-2	1,039,488.944	1,025,720.634	

CURVE # A-38		CURVE # A-41	
A-38	PI STA. = 471+26.81 Δ = 11° 26' 47" (LT) D = 0° 29' 54" R = 11,500.00' T = 1,152.55' L = 2,297.43' E = 57.61' e = N/A	A-41	PI STA. = 496+46.95 Δ = 6° 32' 30" (RT) D = 0° 29' 54" R = 11,500.00' T = 657.20' L = 1,312.98' E = 18.76' e = N/A
A-39	P.C. STA. = 459+74.27	A-42	P.C. STA. = 489+89.74
A-40	P.T. STA. = 482+71.69	A-43	P.T. STA. = 503+02.72

03/31/2005
 PACMIN\JSTPH\cwg\pge2.lpdgn
 LAYOUT: DJP 11/23/03
 DRAWN: DJP 11/23/03
 REVIEWED:

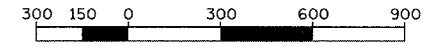

REVISIONS	
NAME	DATE

ILLINOIS DEPARTMENT OF TRANSPORTATION
 CENTERLINE GEOMETRICS
 FAI-57, FAS 642
 SEC NO. 15-23K, 99-00124-01-PV
 COLES COUNTY, ILLINOIS
 SCALE: VERT. HORIZ.
 DATE: 03/31/2005
 DRAWN BY: DJP
 CHECKED BY:

F.A.S. NO.	SECTION	COUNTY	TOTAL SHEETS	SHEET NO.
642	99-00124-01-PV	COLES	157	23
STA.	TO STA.			
FED. ROAD DIST. NO.	ILLINOIS	FED. AID PROJECT		

P.O.T.
C.H. 18 STA.100+00.00
N 1039386.67
E 974980.14

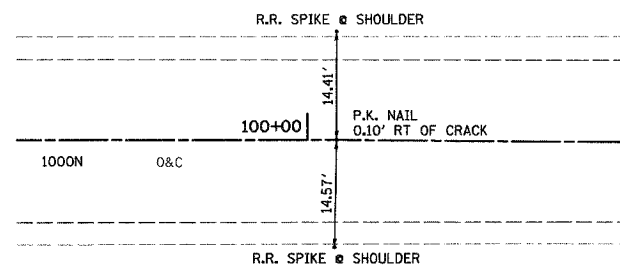

P.I.
C.H. 18 STA.103+43.25
N 1039384.33
E 975323.39

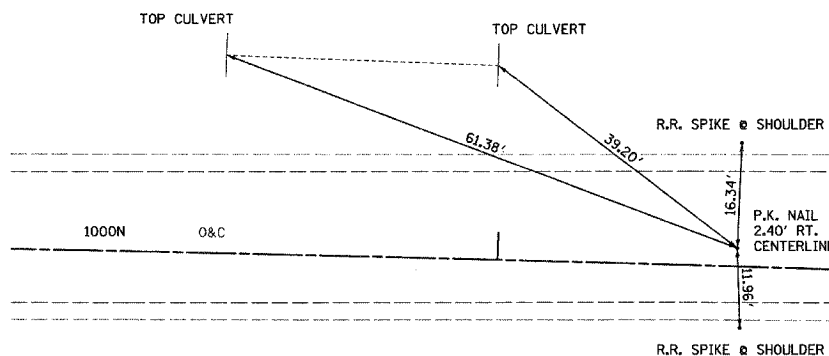

P.I.
C.H. 18 STA.113+94.19
N 1039326.38
E 976372.83

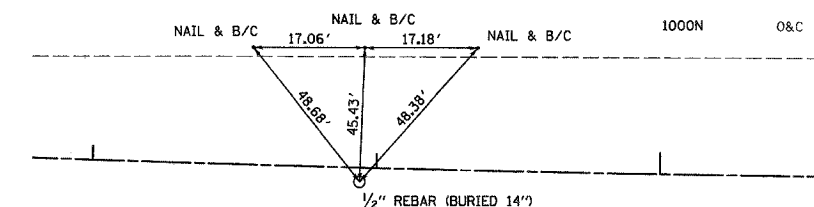

P.I.
C.H. 18 STA.126+69.57
N 1039331.35
E 977648.40

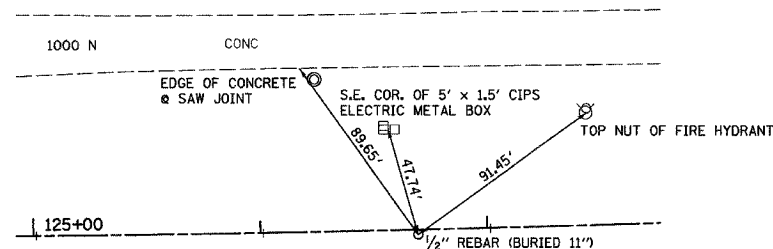

P.O.T.
C.H. 18 STA.137+00
N 1039375.60
E 978677.94

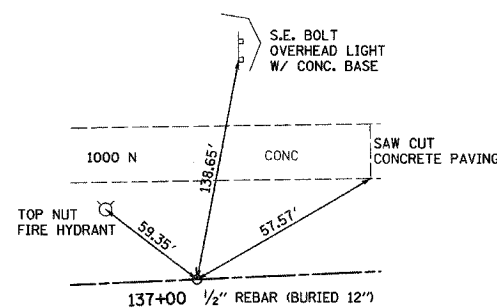

P.I.
C.H. 18 STA.147+41.23
N 1039420.31
E 979718.20

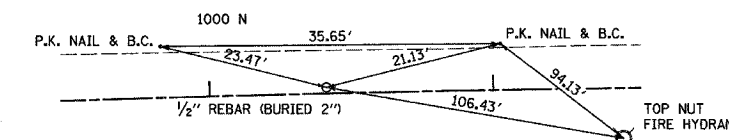

P.O.T.
C.H. 18 STA.155+00
N 1039423.79
E 980477.02

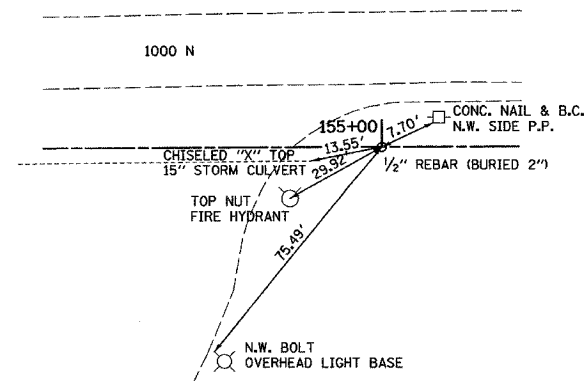

P.I.
C.H. 18 STA.163+43.01
N 1039427.65
E 981320.02

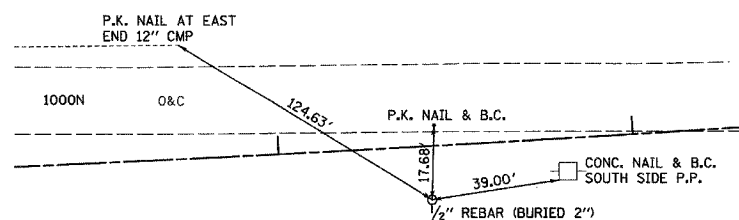

P.O.T.
C.H. 18 STA.175+00.00
N 1039551.56
E 982471.40

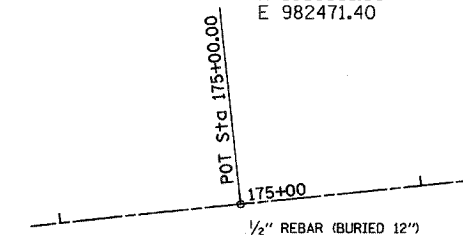

REVISIONS	
NAME	DATE

ILLINOIS DEPARTMENT OF TRANSPORTATION

TIE POINTS

SCALE: VERT. N.T.S.
HORIZ. N.T.S.
DATE 04/08/2005
DRAWN BY CAI
CHECKED BY MED

F.A.S. RTE.	SECTION	COUNTY	TOTAL SHEETS	SHEET NO.
642	99-00124-01-PV	COLES	157	24
STA.		TO STA.		
FED. ROAD DIST. NO.		ILLINOIS FED. AID PROJECT		

P.O.T.
JUGHANDLE STA.100+00.00

N 1039364.58
E 975681.04

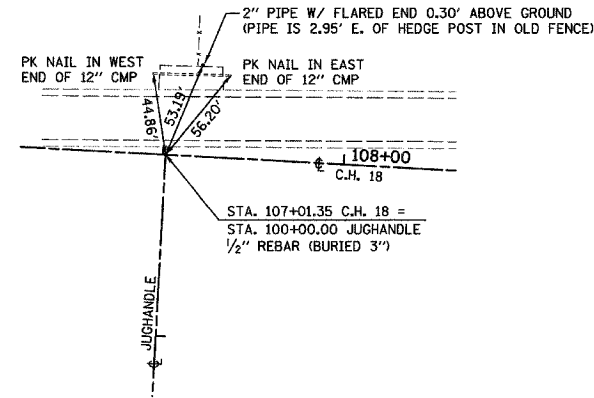

P.C.
JUGHANDLE STA.102+19.76

N 1039145.16
E 975668.93

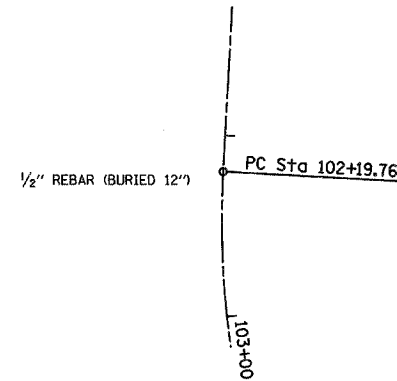

P.T.
JUGHANDLE STA.109+01.01

N 1038634.84
E 976037.96

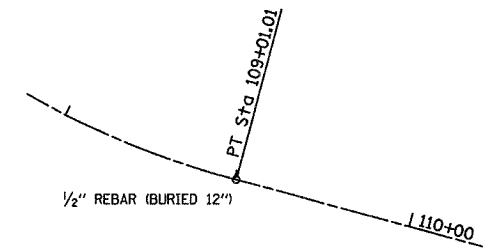

P.O.T.
JUGHANDLE STA.116+58.11

N 1038437.68
E 976768.94

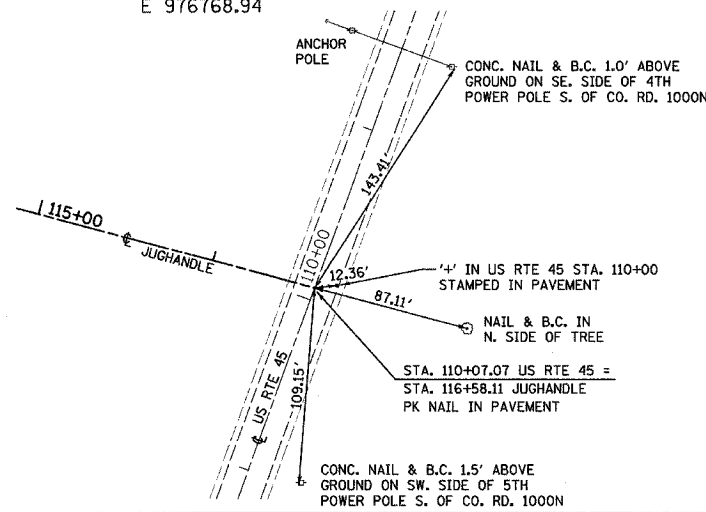

P.O.T.
LOGAN ST. STA.6+94.22

N 1039120.08
E 980819.06

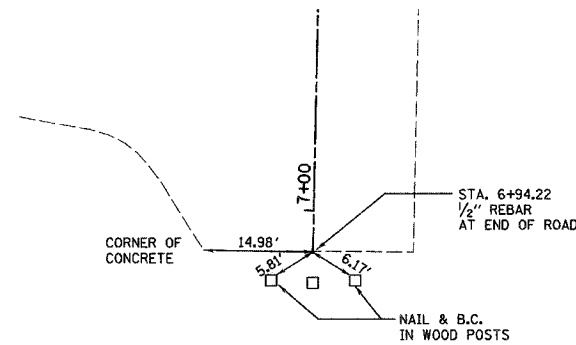

P.O.T.
LOGAN ST. STA.8+98.29

N 1039324.10
E 980823.38

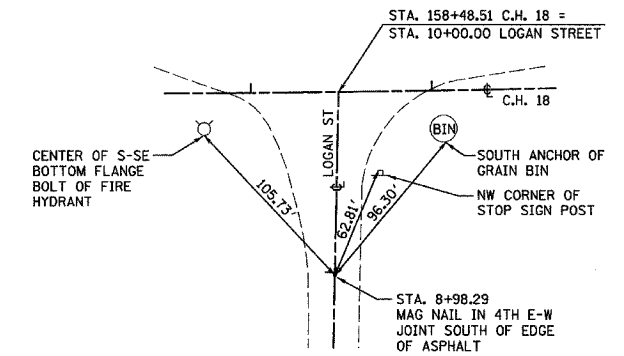

BENCHMARK	DESCRIPTION	STATION	OFFSET	ELEVATION	ROAD
B.M. 500	TOP OF 2" PIPE, 0.3' ABOVE GROUND, 2.9' EAST OF HEDGE POST	107+20	50' LT	702.27	C. H. 18
B.M. 12	S. E. BOLT PAINTED ORANGE ON R. R. SIGNAL FOUNDATION	123+10	104' LT	701.55	C. H. 18
B.M. 600A	TOP CAP BOLT NEXT TO "M" IN MUELLER, 1ST FIRE HYDRANT EAST OF INTERSECTION 620 E./1000 N., SOUTH SIDE OF ROAD	127+44	50' LT	699.58	C. H. 18
B.M. 13	CHISELED SQUARE ON SOUTH SIDE OF LIGHT FOUNDATION AT ENTRANCE TO KAL KAN PARKING LOT	130+57	132' LT	698.82	C. H. 18
B.M. 600B	TOP CAP BOLT NEXT TO "M" IN MUELLER, 2ND FIRE HYDRANT WEST OF AMPAD, S. SIDE OF ROAD	148+45	17' RT	696.79	C. H. 18
B.M. 600C	TOP CAP BOLT NEXT TO "M" IN MUELLER, FIRE HYDRANT EAST SIDE OF EAST ENTRANCE TO AMPAD WAREHOUSE LODGING DOCKS	154+74	14' RT	698.85	C. H. 18
B.M. 15	CHISELED SQUARE ON NORTH SIDE OF GRAIN BIN FOUNDATION	159+05	14' RT	697.35	C. H. 18

REVISIONS	
NAME	DATE

ILLINOIS DEPARTMENT OF TRANSPORTATION

TIE POINTS / BENCHMARKS

SCALE: VERT. N.T.S.
HORIZ. N.T.S.
DATE 04/08/2005

DRAWN BY CAI
CHECKED BY MED

TUG PROJ. #3197022-5
SHEETS.GDD

F.A.S. RTE.	SECTION	COUNTY	TOTAL SHEETS	SHEET NO.
642	99-00124-01-PV	COLES	157	25
STA. 100+00	TO STA. 111+00			
FED. ROAD DIST. NO.	ILLINOIS	FED. AID PROJECT		

NOTE: SEE RIGHT OF WAY PLAN SHEETS FOR RIGHT OF WAY AND EASEMENT INFORMATION

R. O. W. MARKER	
LOCATION	EACH
100+00.00, 30' LT	1
100+00.00, 60' LT	1
100+00.00, 30' RT	1
100+00.00, 60' RT	1
100+55.20, 60' LT	1
100+55.20, 60' RT	1
106+21.19, 60' LT	1
106+21.19, 60' RT	1
108+00.00, 60' LT	1
108+00.00, 60' RT	1
110+54.52, 85' LT	1
110+54.52, 85' RT	1
TOTAL THIS SHEET	10

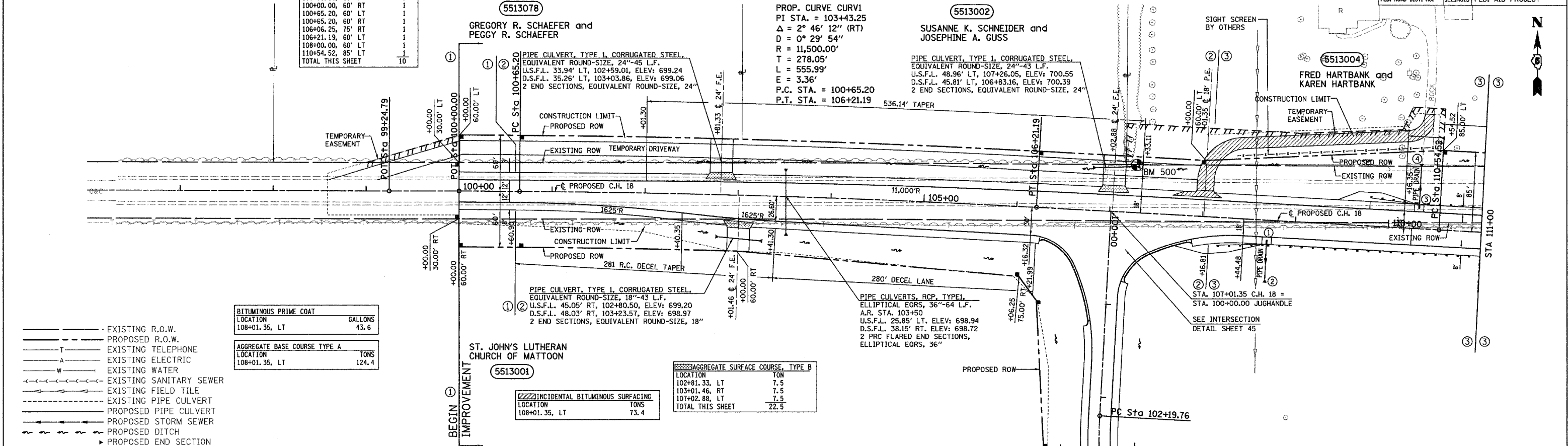
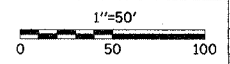

AGGREGATE BASE COURSE TYPE A	
LOCATION	TONS
108+01.35, LT	124.4

AGGREGATE SURFACE COURSE, TYPE B	
LOCATION	TONS
102+81.33, LT	7.5
103+01.46, RT	7.5
107+02.88, LT	7.5
TOTAL THIS SHEET	22.5

INCIDENTAL BITUMINOUS SURFACING	
LOCATION	TONS
108+01.35, LT	73.4

- EXISTING R.O.W.
- - - PROPOSED R.O.W.
- T - EXISTING TELEPHONE
- A - EXISTING ELECTRIC
- W - EXISTING WATER
- - - - - EXISTING SANITARY SEWER
- - - - - EXISTING FIELD TILE
- - - - - EXISTING PIPE CULVERT
- - - - - PROPOSED PIPE CULVERT
- - - - - PROPOSED STORM SEWER
- - - - - PROPOSED DITCH
- ▶ PROPOSED END SECTION

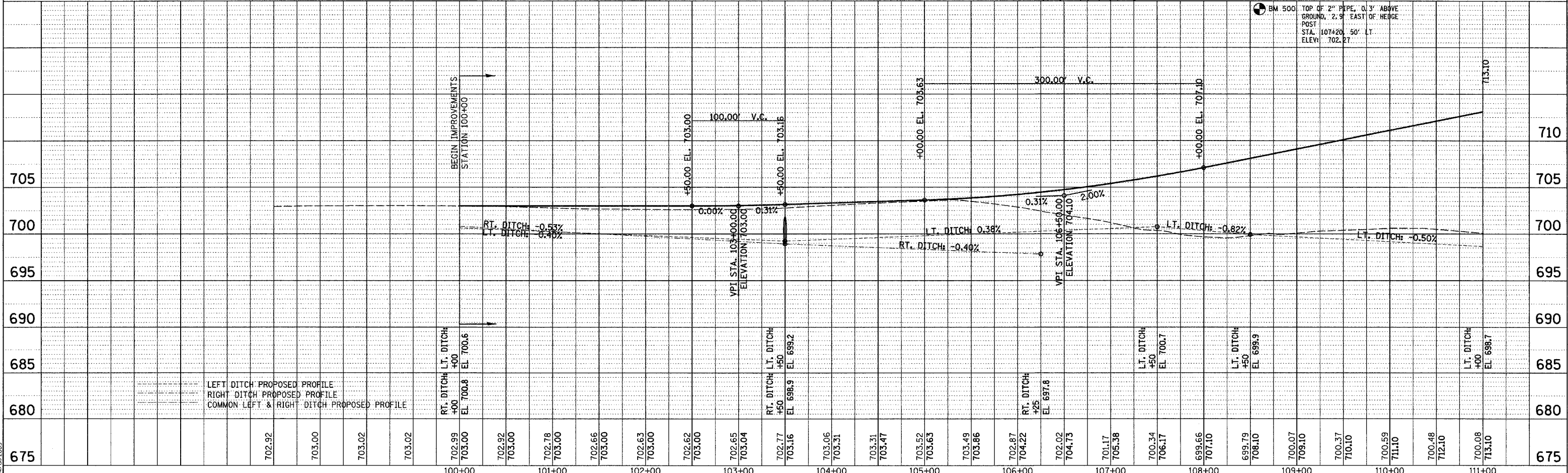

NOTE: SEE RIGHT OF WAY PLAN SHEETS FOR RIGHT OF WAY AND EASEMENT INFORMATION

PROP. CURVE CURV2
 PI STA. = 113+94.19
 $\Delta = 3^\circ 23' 01''$ (LT)
 $D = 0^\circ 29' 54''$
 $R = 11,500.00'$
 $T = 339.67'$
 $L = 679.14'$
 $E = 5.02'$
 P.C. STA. = 110+54.52
 P.T. STA. = 117+33.66

STEEL PLATE BEAM GUARDRAIL, TYPE A	
LOCATION	LN. FT.
108+64.00 RT TO 119+90.47 RT	1128
110+29.00 LT TO 120+05.27 LT	976
123+66.84 RT TO 126+00.00 RT	233
TOTAL THIS SHEET	2337

TERMINAL MARKER, DIRECT APPLIED	
LOCATION	EACH
108+64.00 RT.	1
110+29.00 LT.	1
TOTAL THIS SHEET	2

R.O.W. MARKER	
LOCATION	EACH
117+00.00, 85' LT	1
118+00.00, 95' LT	1
120+39.96, 95' LT	1
123+80.53, 60' LT	1
126+00.00, 100' RT	1
TOTAL THIS SHEET	5

STEEL TRAFFIC BARRIER TERMINAL, TYPE 6	
LOCATION	EACH
119+90.47 RT. TO 120+20.47 RT.	1
120+05.27 LT. TO 120+35.27 LT.	1
123+36.84 RT. TO 123+66.84 RT.	1
TOTAL THIS SHEET	3

SEE SHEET 34 FOR CONTINUATION OF US RTE 45 WORK

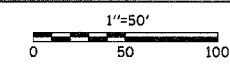

F.A.S. RTE.	SECTION	COUNTY	TOTAL SHEETS	SHEET NO.
642	99-00124-01-PV	COLES	157	26
STA. 111+00		TO STA. 126+00		
FED. ROAD DIST. NO.		ILLINOIS		FED. AID PROJECT

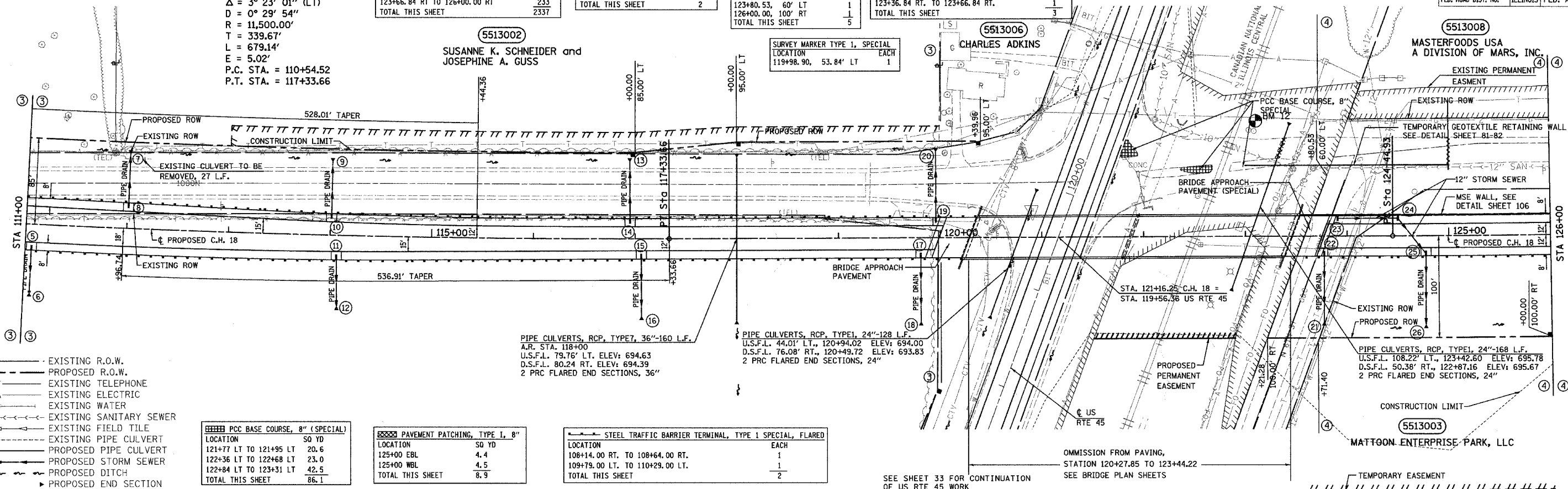

- EXISTING R.O.W.
- - - PROPOSED R.O.W.
- T EXISTING TELEPHONE
- A EXISTING ELECTRIC
- W EXISTING WATER
- EXISTING SANITARY SEWER
- EXISTING FIELD TILE
- EXISTING PIPE CULVERT
- PROPOSED PIPE CULVERT
- PROPOSED STORM SEWER
- PROPOSED DITCH
- ▶ PROPOSED END SECTION

PCC BASE COURSE, 8" (SPECIAL)	
LOCATION	SQ YD
121+77 LT TO 121+95 LT	20.6
122+36 LT TO 122+68 LT	23.0
122+84 LT TO 123+31 LT	42.5
TOTAL THIS SHEET	86.1

PAVEMENT PATCHING, TYPE 1, 8"	
LOCATION	SQ YD
125+00 EBL	4.4
125+00 WBL	4.5
TOTAL THIS SHEET	8.9

STEEL TRAFFIC BARRIER TERMINAL, TYPE 1 SPECIAL, FLARED	
LOCATION	EACH
108+14.00 RT. TO 108+64.00 RT.	1
109+79.00 LT. TO 110+29.00 LT.	1
TOTAL THIS SHEET	2

SEE SHEET 33 FOR CONTINUATION OF US RTE 45 WORK

OMISSION FROM PAVING, STATION 120+27.85 TO 123+44.22
 SEE BRIDGE PLAN SHEETS

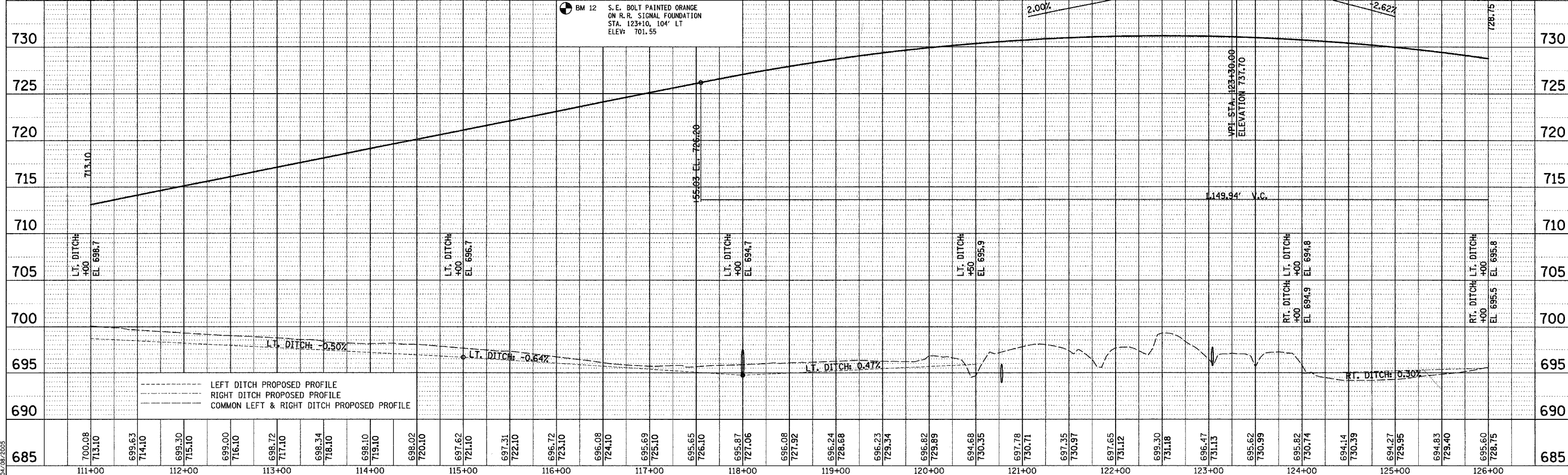

DRAWN BY: S.F.
 CHECKED BY: MED
 TITLE: PROJ. # 91292-5
 SHEET: P1-R-W.dgn
 DATE: 08/28/05

NOTE: SEE RIGHT OF WAY PLAN SHEETS FOR RIGHT OF WAY AND EASEMENT INFORMATION

STEEL TRAFFIC BARRIER TERMINAL, TYPE 6	EACH	1
LOCATION		
134+50.07 LT. TO 134+80.07 LT.		

STEEL TRAFFIC BARRIER TERMINAL, TYPE 1 SPECIAL, FLARED	EACH	1
LOCATION		
136+72.50 RT. TO 137+22.50 RT.		
134+80.07 LT. TO 135+30.07 LT.		
TOTAL THIS SHEET		2

TERMINAL MARKER, DIRECT APPLIED	EACH	1
LOCATION		
137+22.50 RT.		
137+80.00 LT.		
TOTAL THIS SHEET		2

STORM SEWER, CL. A, 24"	
TY 2, 312' @ 0.17%	
U.S.F.L. = 692.05	
D.S.F.L. = 691.52	

SEE SHEETS 49-50 FOR COMMERCIAL ENTRANCE DETAILS

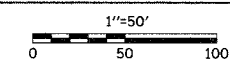

F.A.S. RTE.	SECTION	COUNTY	TOTAL SHEETS	SHEET NO.
642	99-00124-01-PV	COLES	157	27
STA. 126+00	TO STA. 141+00			
FED. ROAD DIST. NO.	ILLINOIS		FED. AID PROJECT	

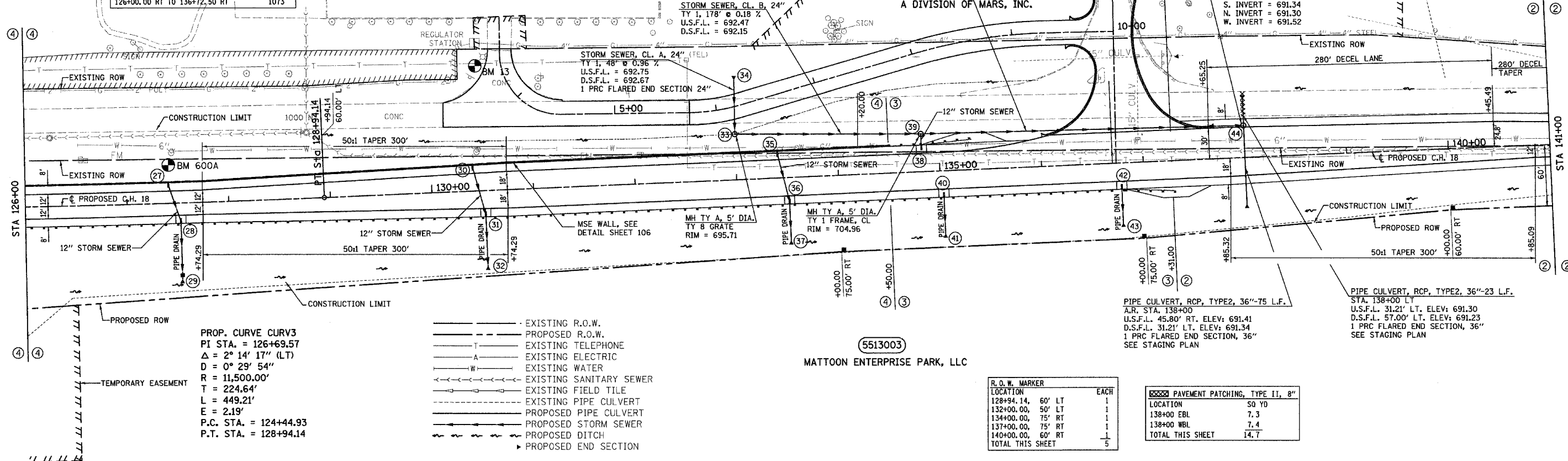

PROP. CURVE CURV3
 PI STA. = 126+69.57
 $\Delta = 2^\circ 14' 17''$ (LT)
 $D = 0^\circ 29' 54''$
 $R = 11,500.00'$
 $T = 224.64'$
 $L = 449.21'$
 $E = 2.19'$
 P.C. STA. = 124+44.93
 P.T. STA. = 128+94.14

- EXISTING R.O.W.
- - - PROPOSED R.O.W.
- - - EXISTING TELEPHONE
- - - EXISTING ELECTRIC
- - - EXISTING WATER
- - - EXISTING SANITARY SEWER
- - - EXISTING FIELD TILE
- - - EXISTING PIPE CULVERT
- - - PROPOSED PIPE CULVERT
- - - PROPOSED STORM SEWER
- - - PROPOSED DITCH
- ▶ PROPOSED END SECTION

R.O.W. MARKER	EACH	
LOCATION		
128+94.14, 60' LT	1	
132+00.00, 50' LT	1	
134+00.00, 75' RT	1	
137+00.00, 75' RT	1	
140+00.00, 60' RT	1	
TOTAL THIS SHEET		5

PAVEMENT PATCHING, TYPE II, 8"	
LOCATION	SQ YD
138+00 EBL	7.3
138+00 WBL	7.4
TOTAL THIS SHEET	14.7

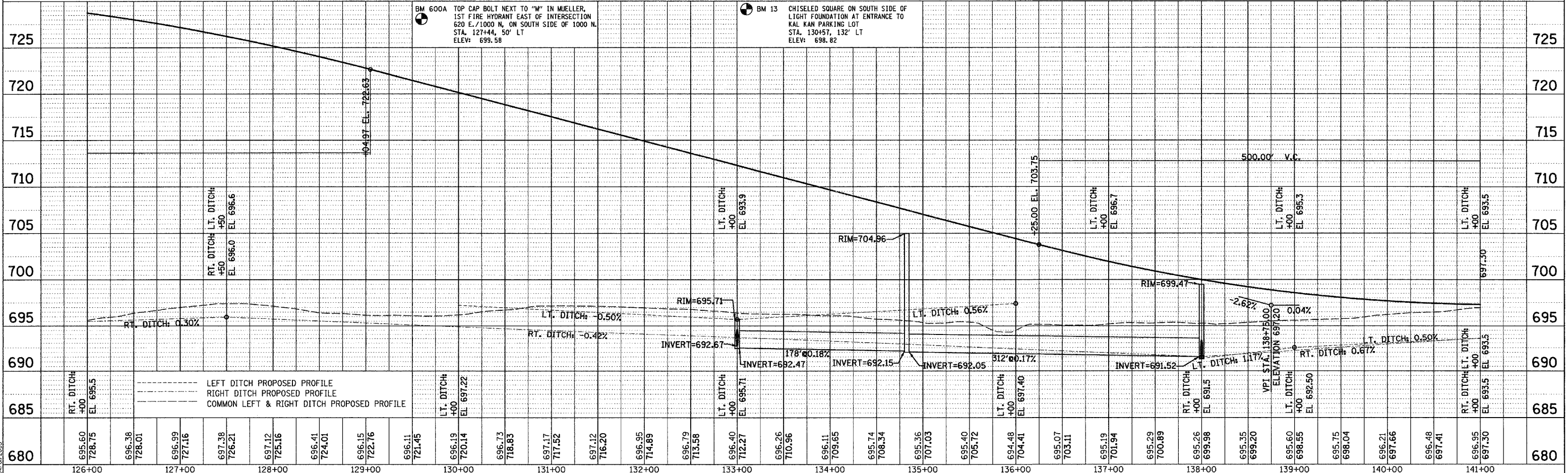

DRAWN BY: S.F. CHK'D BY: M.E.D. TUG PROJ. #1997022-5 11/20/2005

NOTE: SEE RIGHT OF WAY PLAN SHEETS FOR RIGHT OF WAY AND EASEMENT INFORMATION

SURVEY MARKER VAULT		
LOCATION	EACH	
145+24.03, 4.19' RT	1	

R.O.W. MARKER		
LOCATION	EACH	
142+00.00, 50' LT	1	
142+30.00, 80' LT	1	
143+30.00, 80' LT	1	
143+50.00, 60' LT	1	
145+20.55, 60' LT	1	
145+20.55, 60' RT	1	
149+61.84, 60' LT	1	
TOTAL THIS SHEET	7	

F.A.S. RTE.	SECTION	COUNTY	TOTAL SHEETS	SHEET NO.
642	99-00124-01-PV	COLES	157	28
STA. 141+00		TO STA. 156+00		
FED. ROAD DIST. NO.		ILLINOIS FED. AID PROJECT		

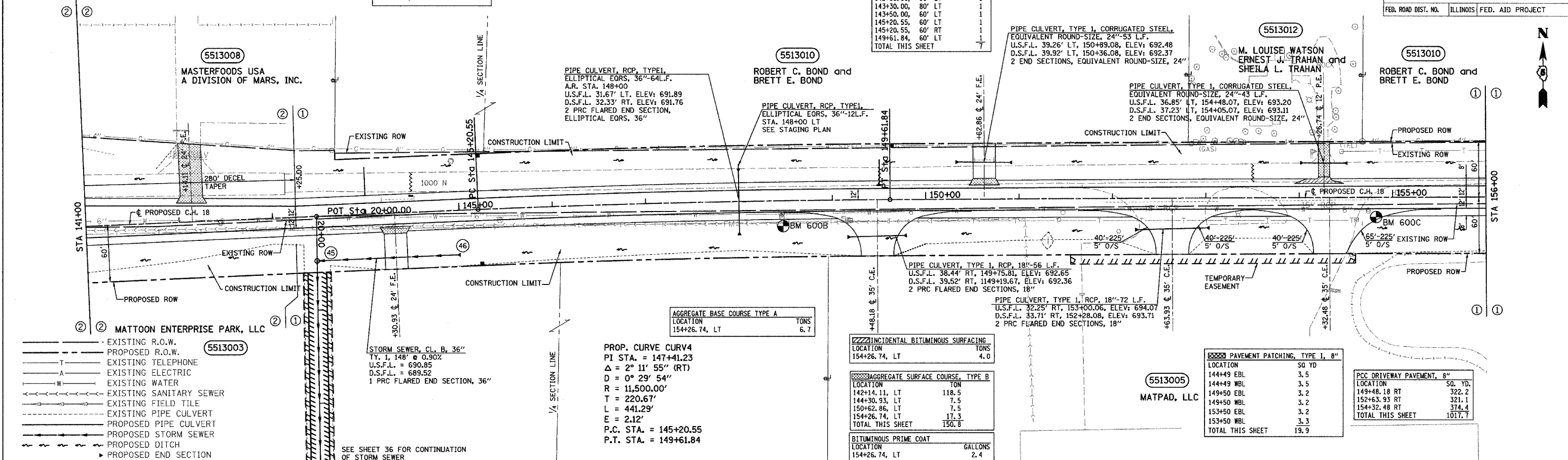
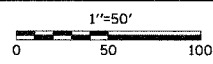

- EXISTING R.O.W.
- - - PROPOSED R.O.W.
- T - EXISTING TELEPHONE
- A - EXISTING ELECTRIC
- W - EXISTING WATER
- S - EXISTING SANITARY SEWER
- F - EXISTING FIELD TILE
- P - EXISTING PIPE CULVERT
- P - PROPOSED PIPE CULVERT
- S - PROPOSED STORM SEWER
- D - PROPOSED DITCH
- P - PROPOSED END SECTION

STORM SEWER, CL. B, 36"	
TY. 1, 148" @ 0.90%	
U.S.F.L. = 690.85	
D.S.F.L. = 689.52	
1 PRC FLARED END SECTION, 36"	

PROP. CURVE CURV4	
PI STA. = 147+41.23	
Δ = 2° 11' 55" (RT)	
D = 0° 29' 54"	
R = 11,500.00'	
T = 220.67'	
L = 441.29'	
E = 2.12'	
P.C. STA. = 145+20.55	
P.T. STA. = 149+61.84	

AGGREGATE BASE COURSE TYPE A	
LOCATION	TONS
154+26.74, LT	6.7

INCIDENTAL BITUMINOUS SURFACING	
LOCATION	TONS
154+26.74, LT	4.0

AGGREGATE SURFACE COURSE, TYPE B	
LOCATION	TONS
142+14.11, LT	118.5
144+30.93, LT	7.5
150+62.86, LT	7.5
154+26.74, LT	17.3
TOTAL THIS SHEET	150.8

BITUMINOUS PRIME COAT	
LOCATION	GALLONS
154+26.74, LT	2.4

PAVEMENT PATCHING, TYPE I, 8"	
LOCATION	SQ YD
144+49 EBL	3.5
144+49 WBL	3.5
149+50 EBL	3.2
149+50 WBL	3.2
153+50 EBL	3.2
153+50 WBL	3.3
TOTAL THIS SHEET	19.9

PCC DRIVEWAY PAVEMENT, 8"	
LOCATION	SQ. YD.
149+48.18 RT	322.2
152+63.93 RT	321.1
154+32.48 RT	374.4
TOTAL THIS SHEET	1017.7

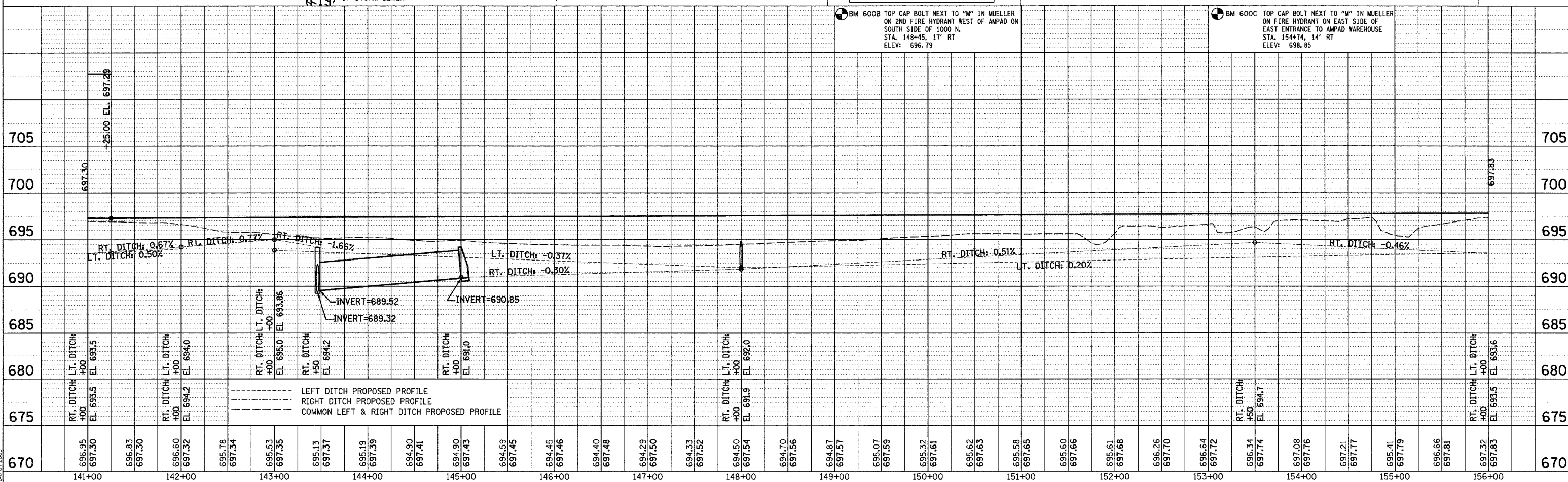

--- LEFT DITCH PROPOSED PROFILE
 - - - RIGHT DITCH PROPOSED PROFILE
 - - - COMMON LEFT & RIGHT DITCH PROPOSED PROFILE

BM 600B TOP CAP BOLT NEXT TO "M" IN MUELLER ON 2ND FIRE HYDRANT WEST OF AMPAD ON SOUTH SIDE OF 1000 N. STA. 148+45, 17' RT ELEV: 696.79

BM 600C TOP CAP BOLT NEXT TO "M" IN MUELLER ON FIRE HYDRANT ON EAST SIDE OF EAST ENTRANCE TO AMPAD WAREHOUSE STA. 154+74, 14' RT ELEV: 698.85

DRAWN BY: S.F. CLK'D BY: M.E.D. TUE. PROJ. #1597022-5 SHEET # 28 OF 28

NOTE: SEE RIGHT OF WAY PLAN SHEETS FOR RIGHT OF WAY AND EASEMENT INFORMATION

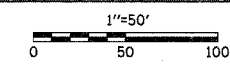

F.A.S. RTE.	SECTION	COUNTY	TOTAL SHEETS	SHEET NO.
642	99-00124-01-PV	COLES	157	29
STA. 156+00		TO STA. 166+00		
FED. ROAD DIST. NO.	ILLINOIS	FED. AID PROJECT		

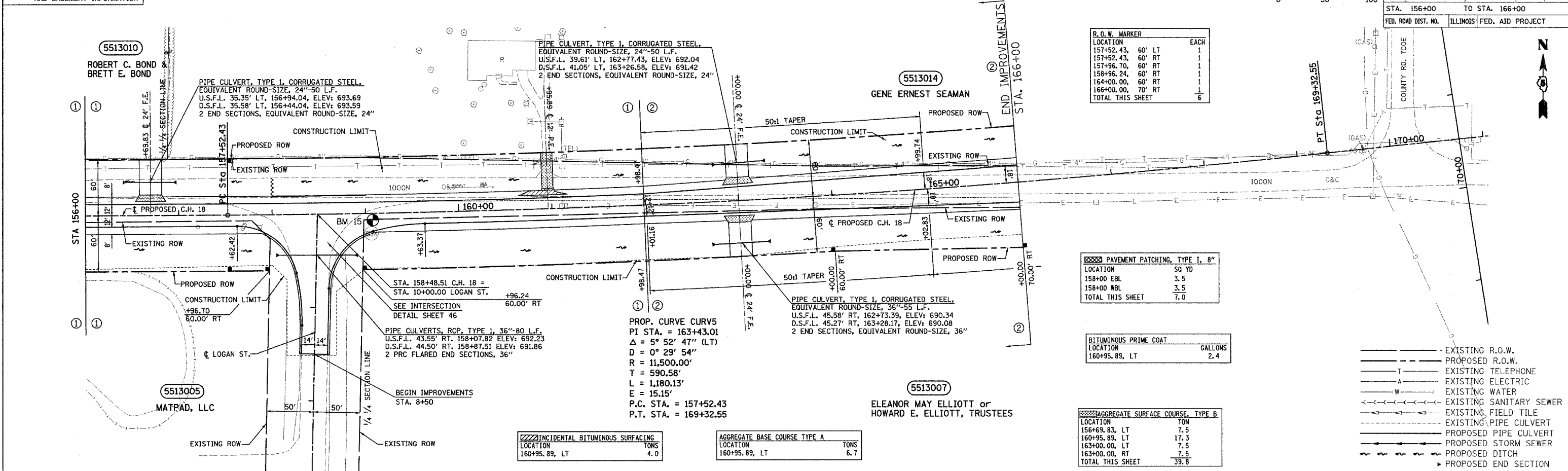

R.O.W. MARKER

LOCATION	EACH
157+52.43, 60' LT	1
157+52.43, 60' RT	1
157+96.70, 60' RT	1
158+96.24, 60' RT	1
164+00.00, 60' RT	1
166+00.00, 70' RT	1
TOTAL THIS SHEET	6

PAVEMENT PATCHING, TYPE I, 8"

LOCATION	SQ YD
158+00 EBL	3.5
158+00 WBL	3.5
TOTAL THIS SHEET	7.0

BITUMINOUS PRIME COAT

LOCATION	GALLONS
160+95.89, LT	2.4

AGGREGATE SURFACE COURSE, TYPE B

LOCATION	TON
156+69.83, LT	7.5
160+95.89, LT	17.3
163+00.00, LT	7.5
163+00.00, RT	7.5
TOTAL THIS SHEET	39.8

- EXISTING R.O.W.
- - - PROPOSED R.O.W.
- T — EXISTING TELEPHONE
- A — EXISTING ELECTRIC
- W — EXISTING WATER
- — — EXISTING SANITARY SEWER
- — — EXISTING FIELD TILE
- — — EXISTING PIPE CULVERT
- — — PROPOSED PIPE CULVERT
- — — PROPOSED STORM SEWER
- — — PROPOSED DITCH
- ▶ PROPOSED END SECTION

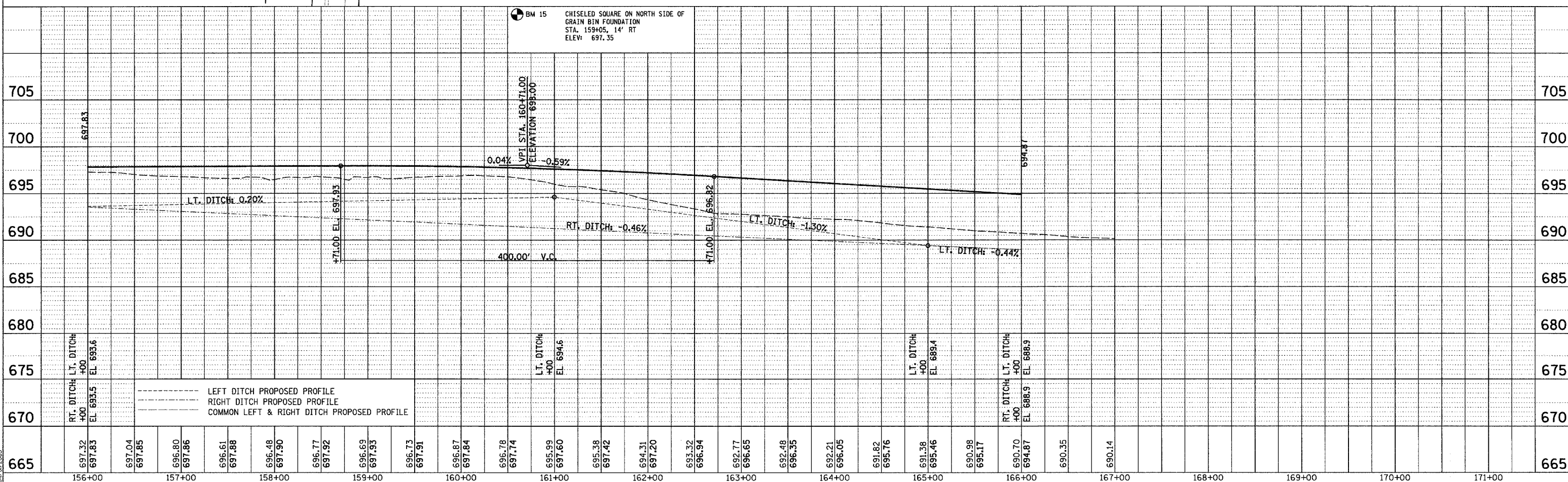

DRAWN BY: S.F.
 CHECKED BY: M.E.D.
 TITLE: PROJ. #397022-5
 SHEET: P.L.P. - M.D.P.
 DATE: 02/20/05

NOTE: SEE RIGHT OF WAY PLAN SHEETS FOR RIGHT OF WAY AND EASEMENT INFORMATION

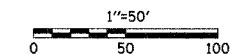

F.A.S. RTE.	SECTION	COUNTY	TOTAL SHEETS	SHEET NO.
642	99-00124-01-PV	COLES	157	30
STA. 100+00		TO STA. 106+00		
FED. ROAD DIST. NO.	ILLINOIS	FED. AID PROJECT		

S. E. = 6.00%
 SUPERELEVATION TRANSITIONS:
 -1.5% TO 6.0% RT STA 100+82.26 TO RT STA 102+69.76
 -1.5% TO -6.0% LT STA 101+57.26 TO LT STA 102+69.76
 -6.0% TO -1.5% RT STA 108+51.01 TO RT STA 109+63.51
 6.0% TO -1.5% RT STA 108+51.01 TO RT STA 110+38.51

PIPE CULVERTS, RCP, TYPE I,
 ELLIPTICAL EQRS, 36"-56" L.F.
 U.S.F.L. 24.23' RT, 104+84.76 ELEV: 693.97
 D.S.F.L. 24.68' LT, 105+11.71 ELEV: 693.27
 2' PRC FLARED END SECTIONS,
 ELLIPTICAL EQRS, 36"

COMBINATION CONCRETE CURB & GUTTER TYPE B-6, 24

LOCATION	LIN. FT
100+24.98 LT TO 100+74.03 RT	91.3
100+31.00 RT TO 101+23.17 RT	115.7
TOTAL THIS SHEET	207.0

AGGREGATE SURFACE COURSE, TYPE B

LOCATION	TON
106+00.00, LT	7.5

R. O. W. MARKER

LOCATION	EACH
101+00.00, 75' RT	1
102+50.00, 60' RT	1
TOTAL THIS SHEET	2

- EXISTING R.O.W.
- - - PROPOSED R.O.W.
- T EXISTING TELEPHONE
- A EXISTING ELECTRIC
- W EXISTING WATER
- - - - - EXISTING SANITARY SEWER
- - - - - EXISTING FIELD TILE
- - - - - EXISTING PIPE CULVERT
- - - - - PROPOSED PIPE CULVERT
- - - - - PROPOSED STORM SEWER
- - - - - PROPOSED DITCH
- ▶ PROPOSED END SECTION

5513004
 FRED HARTBANK and
 KAREN HARTBANK

5513002
 SUSANNE K. SCHNEIDER and
 JOSEPHINE A. GUSS

5513001
 ST. JOHN'S LUTHERAN
 CHURCH OF MATTOON

PROP. CURVE CURVE1-45
 PI STA. = 106+25.13
 $\Delta = 78^\circ 03' 58''$ (LT)
 D = 11' 27' 33"
 R = 500.00'
 T = 405.37'
 L = 681.25'
 E = 143.68'
 P.C. STA. = 102+19.76
 P.T. STA. = 109+01.01
 $e = 6\%$
 ATTAIN S.E. STA. 101+69.76 TO 103+19.76
 REMOVE S.E. STA. 108+01.01 TO 109+51.01

BM 500 TOP OF 2" PIPE, 0.3' ABOVE GROUND, 2.9' EAST OF HEDGE POST
 STA. 107+20, 50' LT
 ELEV: 702.27

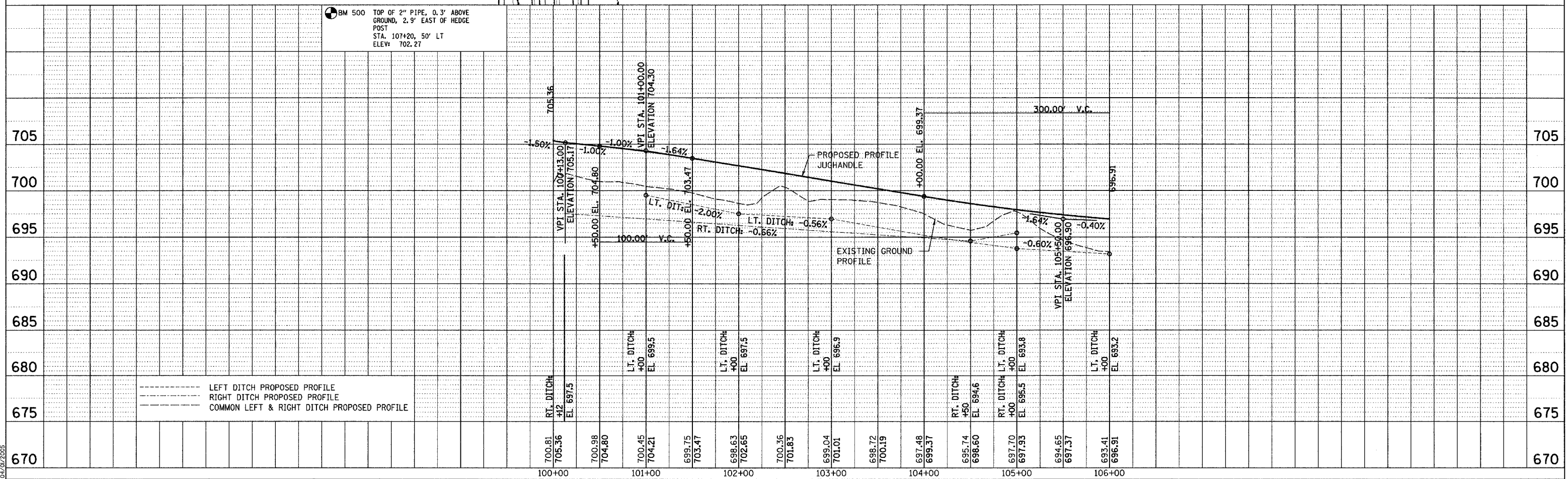

DRAWN BY: S.J.F.
 CHECKED BY: M.E.D.
 TUC PROJ. #1597022-5
 SHEET PLOT: W.0501
 5/12/2025

NOTE: SEE RIGHT OF WAY PLAN SHEETS FOR RIGHT OF WAY AND EASEMENT INFORMATION

S. E. = 6.00%
 SUPERELEVATION TRANSITIONS:
 -1.5% TO 6.0% RT STA 100+82.26 TO RT STA 102+69.76
 -1.5% TO -6.0% LT STA 101+57.26 TO LT STA 102+69.76
 -6.0% TO -1.5% RT STA 108+51.01 TO RT STA 109+63.51
 6.0% TO -1.5% RT STA 108+51.01 TO RT STA 110+38.51

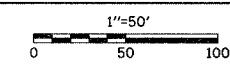

F.A.S. RTE.	SECTION	COUNTY	TOTAL SHEETS	SHEET NO.
642	99-00124-01-PV	COLES	157	31
STA. 106+00		TO STA. 116+58.11		
FED. ROAD DIST. NO.		ILLINOIS	FED. AID PROJECT	

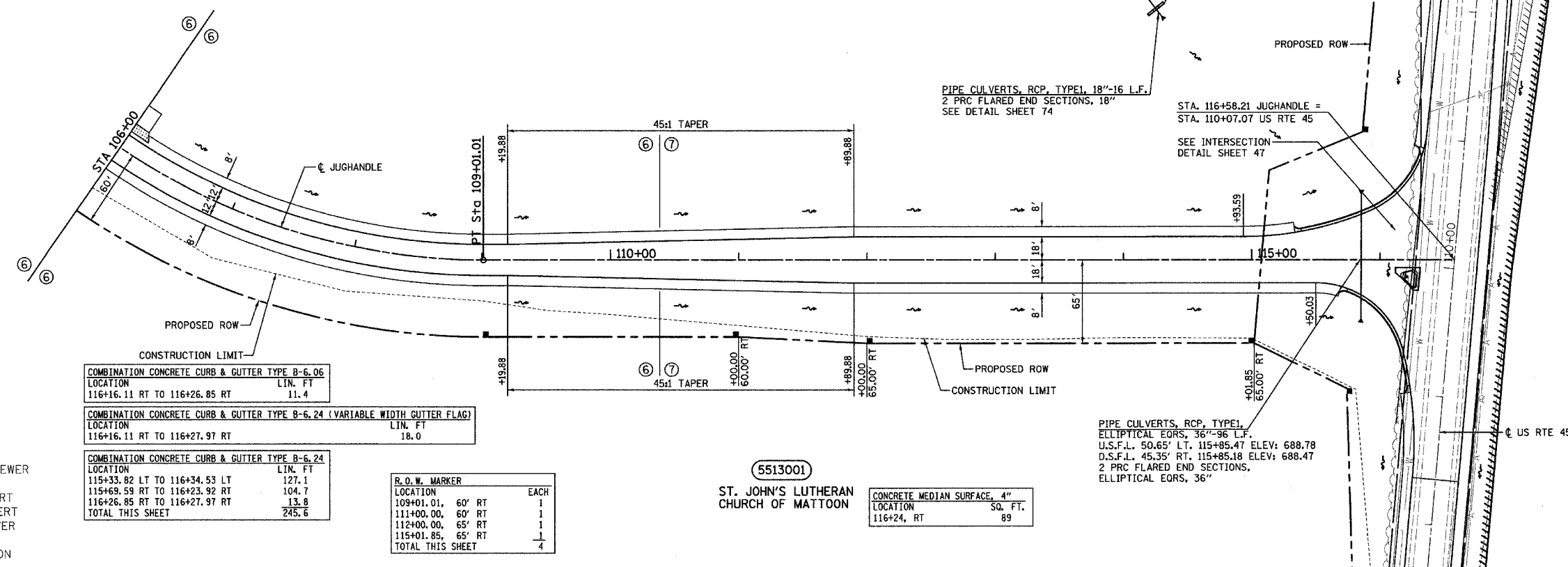

- EXISTING R.O.W.
- - - PROPOSED R.O.W.
- T - EXISTING TELEPHONE
- A - EXISTING ELECTRIC
- W - EXISTING WATER
- S - EXISTING SANITARY SEWER
- F - EXISTING FIELD TILE
- P - EXISTING PIPE CULVERT
- P - PROPOSED PIPE CULVERT
- S - PROPOSED STORM SEWER
- D - PROPOSED DITCH
- P - PROPOSED END SECTION

COMBINATION CONCRETE CURB & GUTTER TYPE B-6.06	
LOCATION	LIN. FT
116+16.11 RT TO 116+26.85 RT	11.4
COMBINATION CONCRETE CURB & GUTTER TYPE B-6.24 (VARIABLE WIDTH GUTTER FLAG)	
LOCATION	LIN. FT
116+16.11 RT TO 116+27.97 RT	18.0
COMBINATION CONCRETE CURB & GUTTER TYPE B-6.24	
LOCATION	LIN. FT
115+33.82 LT TO 116+34.53 LT	127.1
115+69.59 RT TO 116+23.92 RT	104.7
116+26.85 RT TO 116+27.97 RT	13.8
TOTAL THIS SHEET	245.6

R.O.W. MARKER		
LOCATION	TYPE	EACH
109+01.01, 60' RT	1	1
111+00.00, 60' RT	1	1
112+00.00, 65' RT	1	1
115+01.85, 65' RT	1	1
TOTAL THIS SHEET		4

CONCRETE MEDIAN SURFACE, 4"	
LOCATION	SQ. FT.
116+24, RT	89

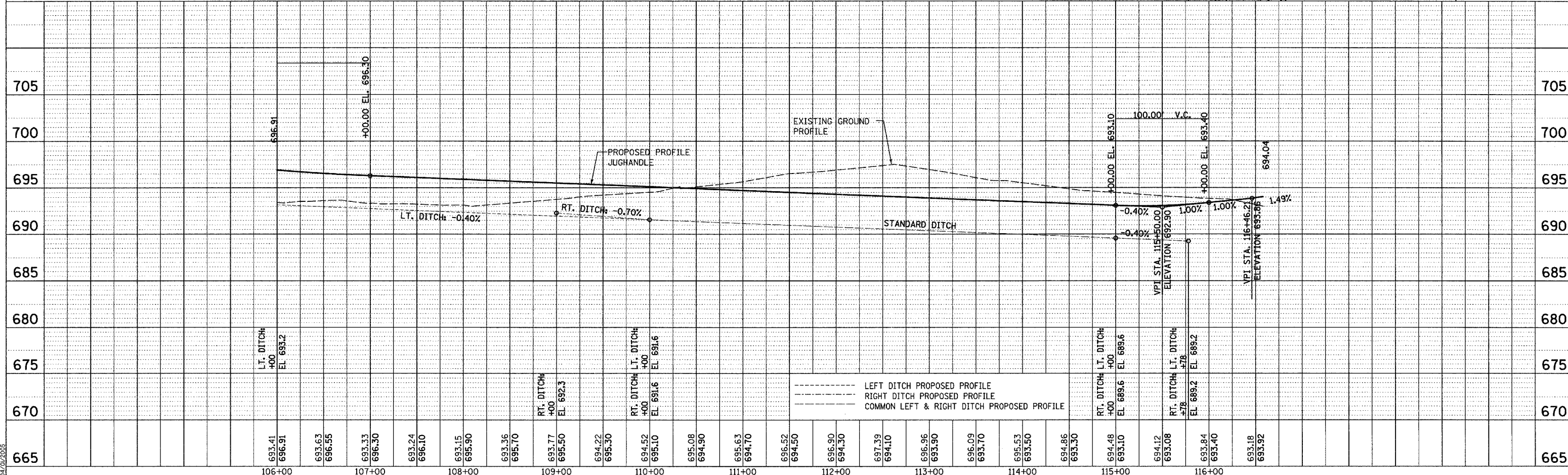

--- LEFT DITCH PROPOSED PROFILE
 --- RIGHT DITCH PROPOSED PROFILE
 --- COMMON LEFT & RIGHT DITCH PROPOSED PROFILE

DRAWN BY: S.F.
 CHKD BY: MED
 TUG PROJ: 1997022-5
 SHEET: PR-M-09
 04/02/2005

NOTE: SEE RIGHT OF WAY PLAN SHEETS FOR RIGHT OF WAY AND EASEMENT INFORMATION

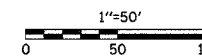

F.A.S. RTE.	SECTION	COUNTY	TOTAL SHEETS	SHEET NO.
642	99-00124-01-PV	COLES	157	32
STA. 97+50		TO STA. 102+50		
FED. ROAD DIST. NO.		ILLINOIS		FED. AID PROJECT

BIT. CONC. BASE COURSE, SUPERPAVE, 9"	
LOCATION	SO. YD.
101+14.00 LT TO 102+50.00 LT	31.1
101+14.00 RT TO 102+50.00 RT	31.9
TOTAL THIS SHEET	63.0

SUBBASE GRANULAR MATERIAL, TYPE B, 4"	
LOCATION	SO. YD.
101+14.00 LT TO 102+50.00 LT	31.1
101+14.00 RT TO 102+50.00 RT	31.9
TOTAL THIS SHEET	63.0

STRIP REFLECTIVE CRACK CONTROL	
LOCATION	FOOT
101+14.00 LT TO 102+50.00 LT	136
101+14.00 RT TO 102+50.00 RT	136
TOTAL THIS SHEET	272

- — — — — EXISTING R.O.W.
- — — — — PROPOSED R.O.W.
- T — — — — EXISTING TELEPHONE
- A — — — — EXISTING ELECTRIC
- W — — — — EXISTING WATER
- S — — — — EXISTING SANITARY SEWER
- F — — — — EXISTING FIELD TILE
- C — — — — EXISTING PIPE CULVERT
- P — — — — PROPOSED PIPE CULVERT
- S — — — — PROPOSED STORM SEWER
- D — — — — PROPOSED DITCH
- ▶ — — — — PROPOSED END SECTION

R.O.W. MARKER	
LOCATION	EACH
97+50.00, 30' LT	1
99+50.00, 40' LT	1
TOTAL THIS SHEET	2

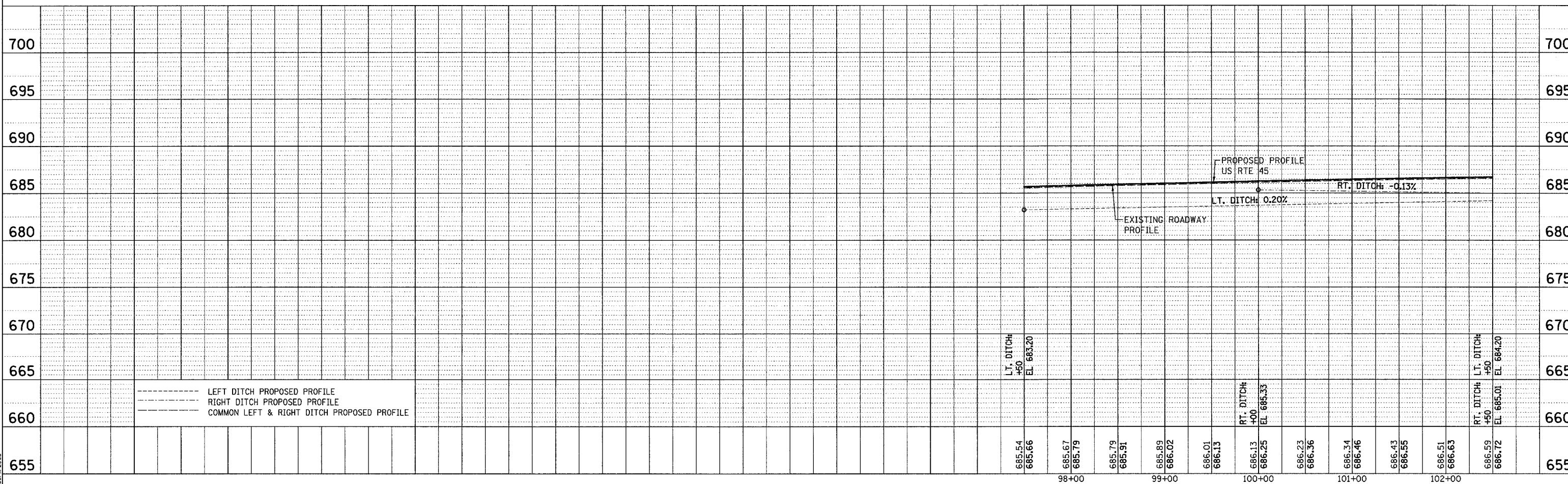
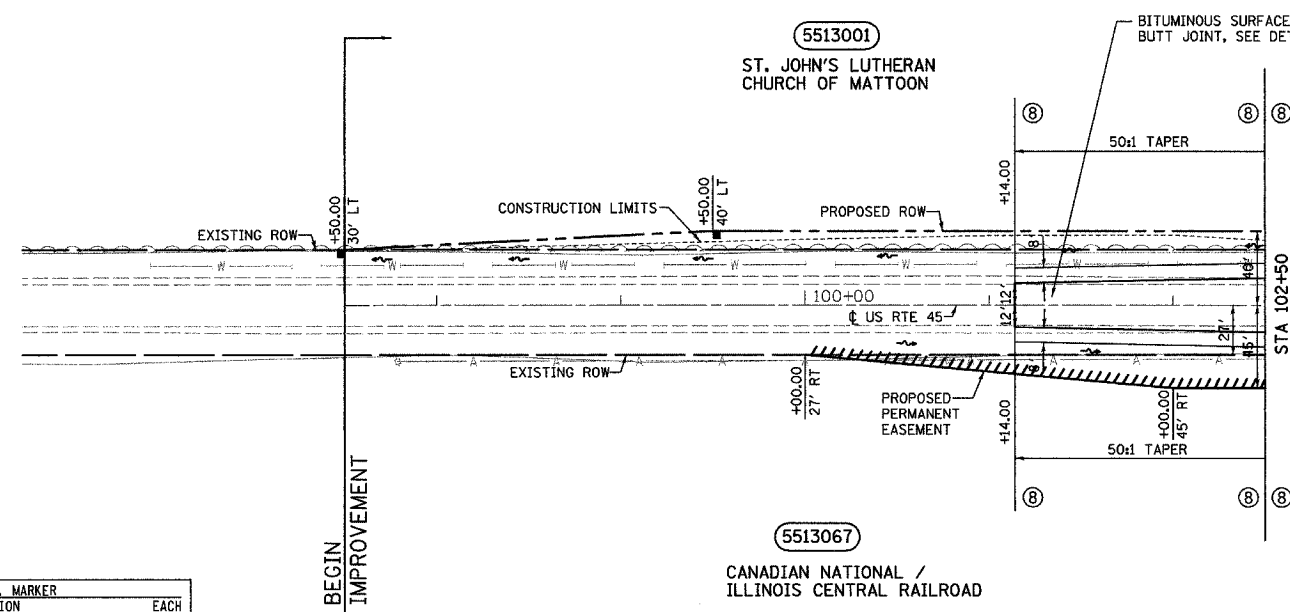

DRAWN BY: SUP
 TUG PROJ: M397022-5
 SHEET: PR-W-001
 08/17/2005

NOTE: SEE RIGHT OF WAY PLAN SHEETS FOR RIGHT OF WAY AND EASEMENT INFORMATION

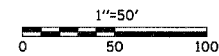

F.A.S. RTE.	SECTION	COUNTY	TOTAL SHEETS	SHEET NO.
642	99-00124-01-PV	COLES	157	33
STA. 102+50		TO STA. 117+50		
FED. ROAD DIST. NO.		ILLINOIS		FED. AID PROJECT

BIT. CONC. BASE COURSE, SUPERPAVE, 9"	
LOCATION	SQ. YD.
102+50.00 LT TO 115+77.67 LT	1495.0
102+50.00 RT TO 113+80.29 RT	660.9
TOTAL THIS SHEET	2155.9

SUBBASE GRANULAR MATERIAL, TYPE B, 4"	
LOCATION	SQ. YD.
102+50.00 LT TO 115+77.67 LT	1495.0
102+50.00 RT TO 113+80.29 RT	660.9
TOTAL THIS SHEET	2155.9

STRIP REFLECTIVE CRACK CONTROL	
LOCATION	FOOT
102+50.00 LT TO 115+77.67 LT	1327.7
102+50.00 RT TO 113+80.29 RT	1130.3
TOTAL THIS SHEET	2458.0

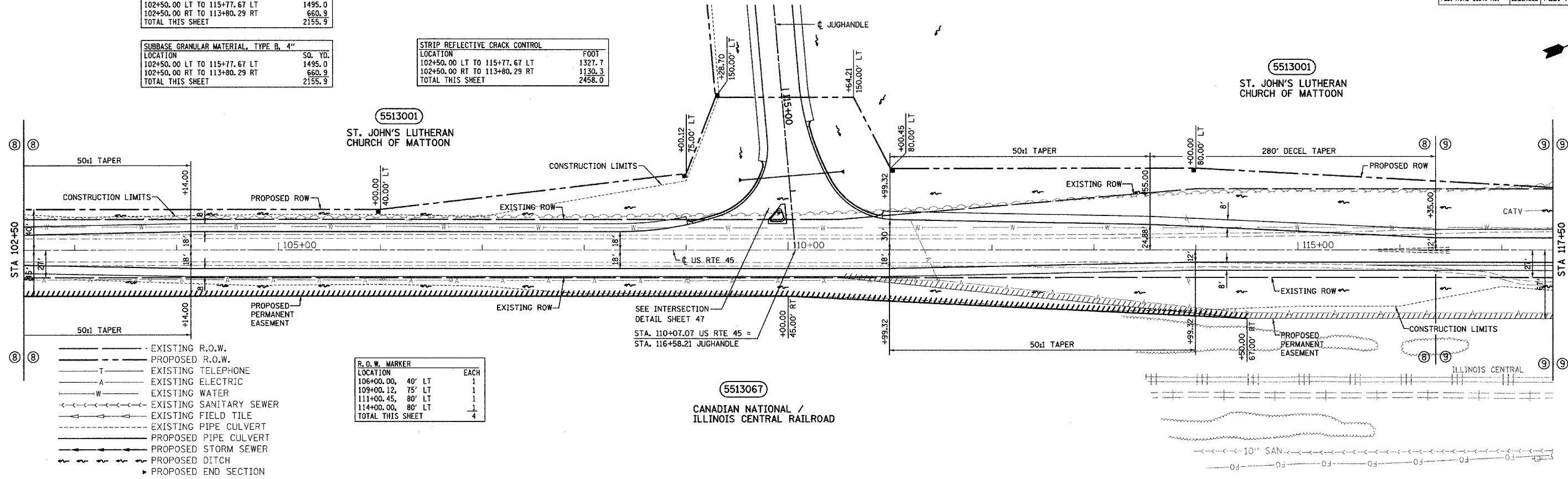

R.O.W. MARKER	
LOCATION	EACH
106+00.00, 40' LT	1
109+00.12, 75' LT	1
111+00.45, 80' LT	1
114+00.00, 80' LT	1
TOTAL THIS SHEET	4

- EXISTING R.O.W.
- PROPOSED R.O.W.
- T- EXISTING TELEPHONE
- A- EXISTING ELECTRIC
- W- EXISTING WATER
- S- EXISTING SANITARY SEWER
- F- EXISTING FIELD TILE
- P- EXISTING PIPE CULVERT
- P- PROPOSED PIPE CULVERT
- S- PROPOSED STORM SEWER
- D- PROPOSED DITCH
- ▶ PROPOSED END SECTION

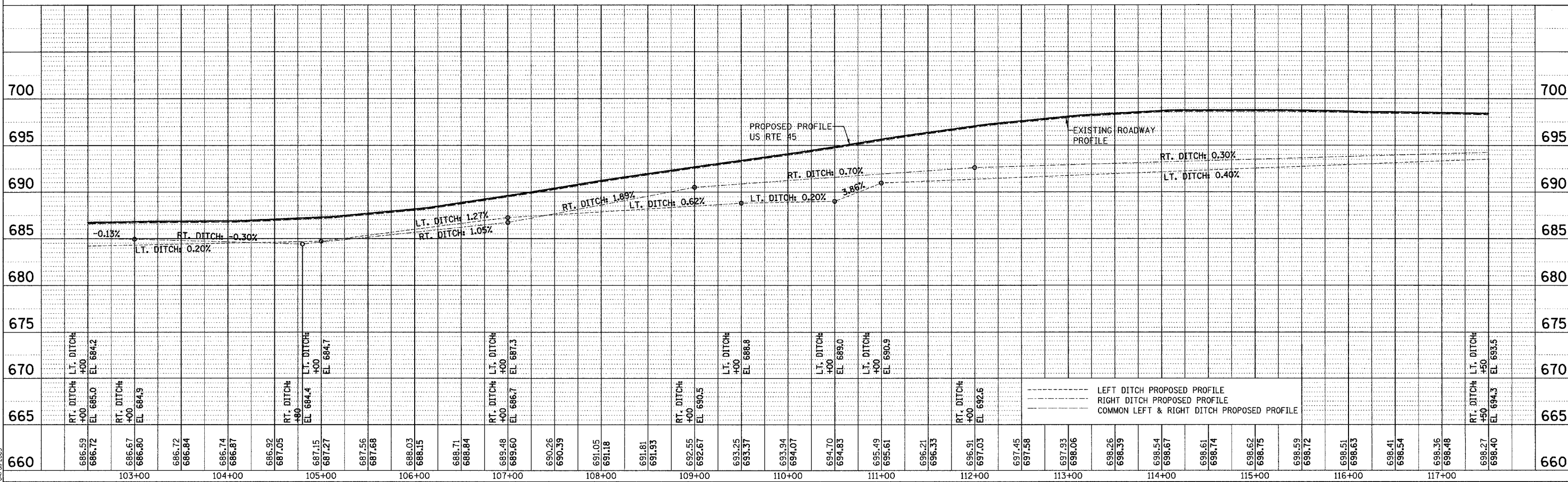

DRAWN BY: S.F.
 CHECKED BY: M.E.D.
 TUG PROJ. #397022-5
 SHEET PLOT: P1-W.dgn
 07/22/05

NOTE: SEE RIGHT OF WAY PLAN SHEETS FOR RIGHT OF WAY AND EASEMENT INFORMATION

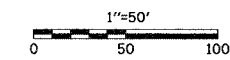

F.A.S. RTE.	SECTION	COUNTY	TOTAL SHEETS	SHEET NO.
642	99-00124-01-PV	COLES	157	34
STA. 117+50		TO STA. 132+50		
FED. ROAD DIST. NO.		ILLINOIS	FED. AID PROJECT	

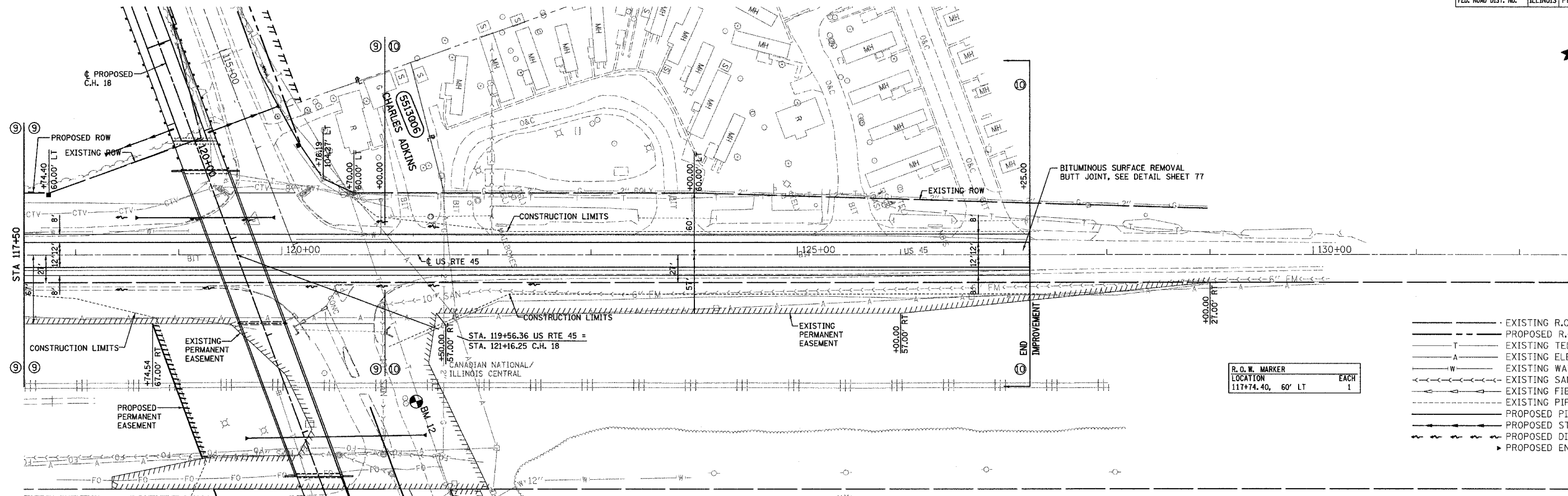

R.O.W. MARKER
LOCATION 117+74.40, 60' LT
EACH 1

BM 12
S. E. BOLT PAINTED ORANGE
ON R. R. SIGNAL FOUNDATION
STA. 123+10, 104' LT
ELEV: 701.55

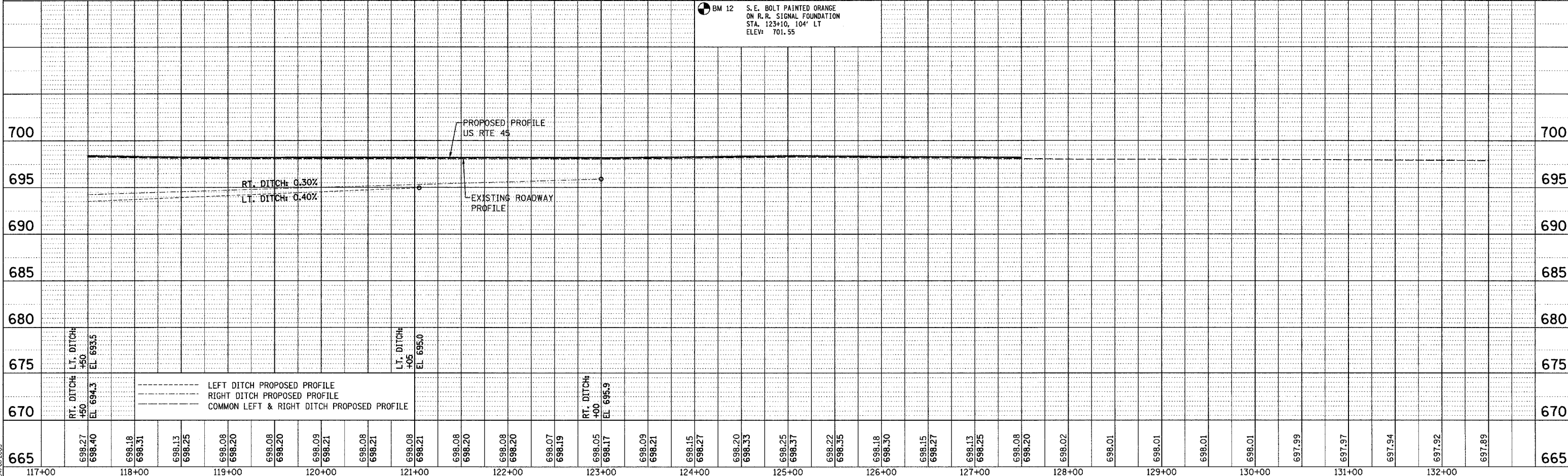

DRAWN BY: S.F.
 CHK'D BY: M.E.D.
 TLU PROJ. #197022-5
 SHEET PLOT - W.dgn
 04/07/2025

NOTE: SEE RIGHT OF WAY PLAN SHEETS FOR RIGHT OF WAY AND EASEMENT INFORMATION

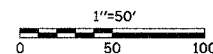

F.A.S. RTE.	SECTION	COUNTY	TOTAL SHEETS	SHEET NO.
642	99-00124-01-PV	COLES	157	35
STA. 8+50	TO STA. 10+00			
FED. ROAD DIST. NO.	ILLINOIS	FED. AID PROJECT		

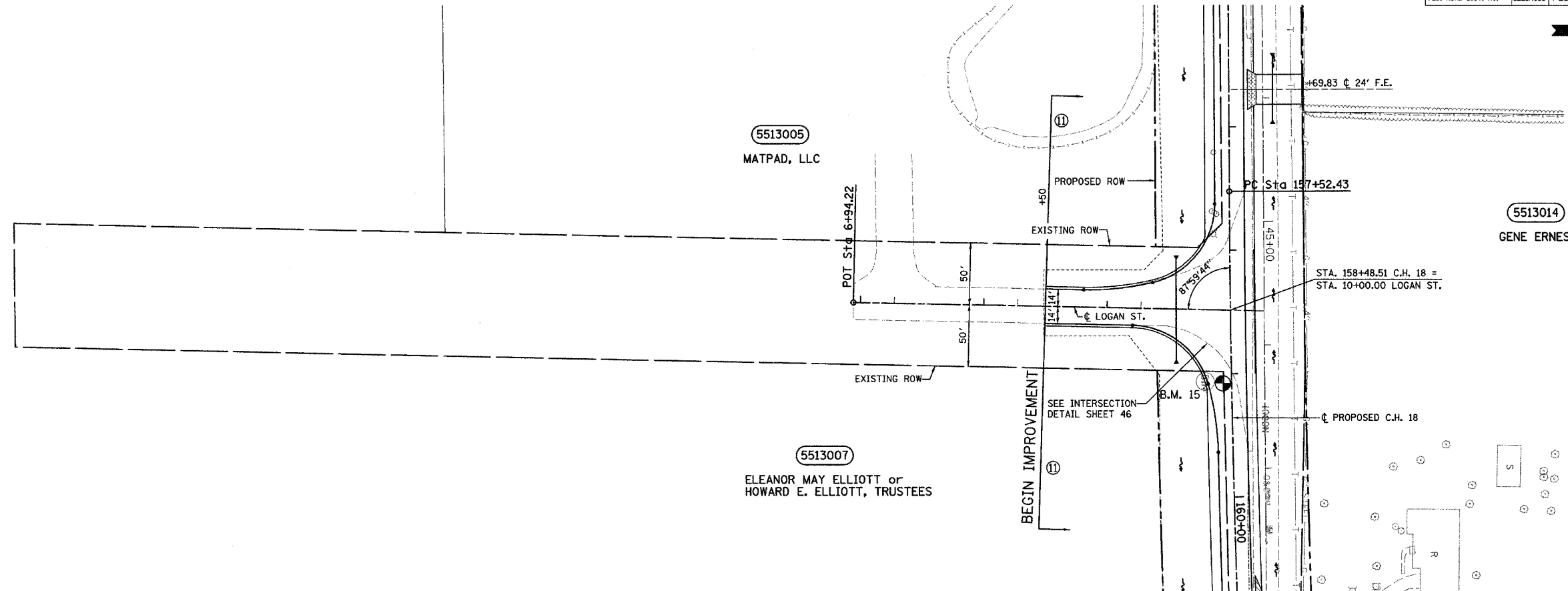

- EXISTING R.O.W.
- - - PROPOSED R.O.W.
- T - EXISTING TELEPHONE
- A - EXISTING ELECTRIC
- W - EXISTING WATER
- - - - - EXISTING SANITARY SEWER
- - - - - EXISTING FIELD TILE
- - - - - EXISTING PIPE CULVERT
- - - - - PROPOSED PIPE CULVERT
- - - - - PROPOSED STORM SEWER
- - - - - PROPOSED DITCH
- ▶ PROPOSED END SECTION

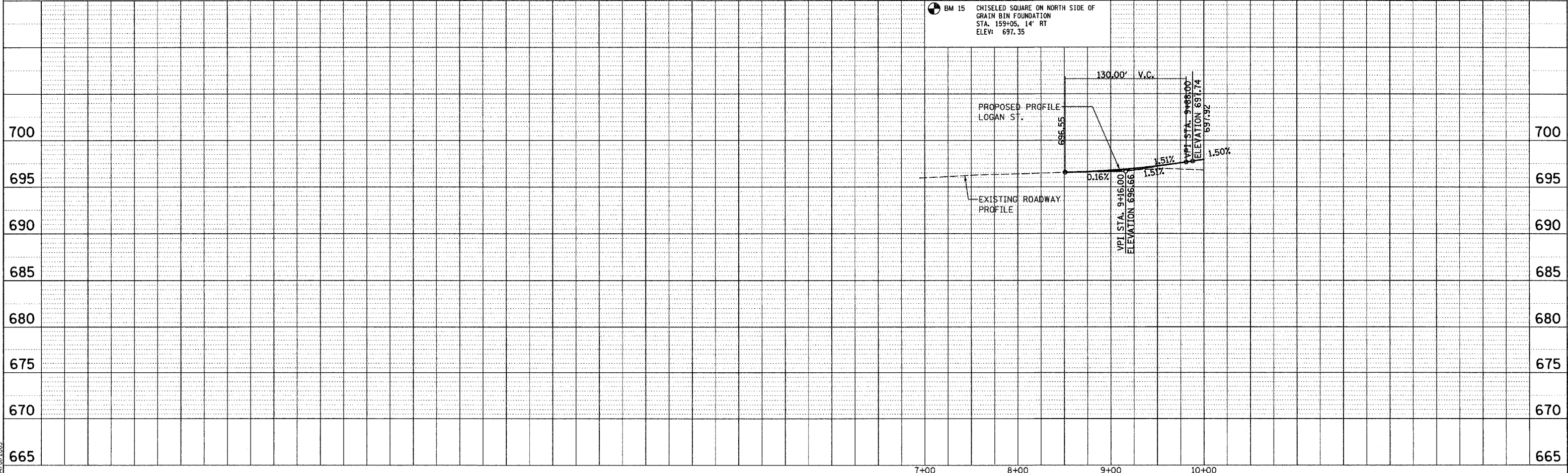

BM 15 CHISELED SQUARE ON NORTH SIDE OF GRAIN BIN FOUNDATION STA. 159+05.14' RT ELEV: 697.35

DRAWN BY: SJF
 CK'D BY: MED
 TUC FROM: PR-1001
 04/20/2005

F.A.S. RTE.	SECTION	COUNTY	TOTAL SHEETS	SHEET NO.
642	99-00124-01-PV	COLES	157	36
STA. TO STA.				
FED. ROAD DIST. NO.	ILLINOIS	FED. AID PROJECT		

NOTE: SEE RIGHT OF WAY PLAN SHEETS FOR RIGHT OF WAY AND EASEMENT INFORMATION

- EXISTING R.O.W.
- - - PROPOSED R.O.W.
- - - EXISTING TELEPHONE
- - - EXISTING ELECTRIC
- - - EXISTING WATER
- - - EXISTING SANITARY SEWER
- - - EXISTING FIELD TILE
- - - EXISTING PIPE CULVERT
- - - PROPOSED PIPE CULVERT
- - - PROPOSED STORM SEWER
- - - PROPOSED DITCH
- ▶ PROPOSED END SECTION

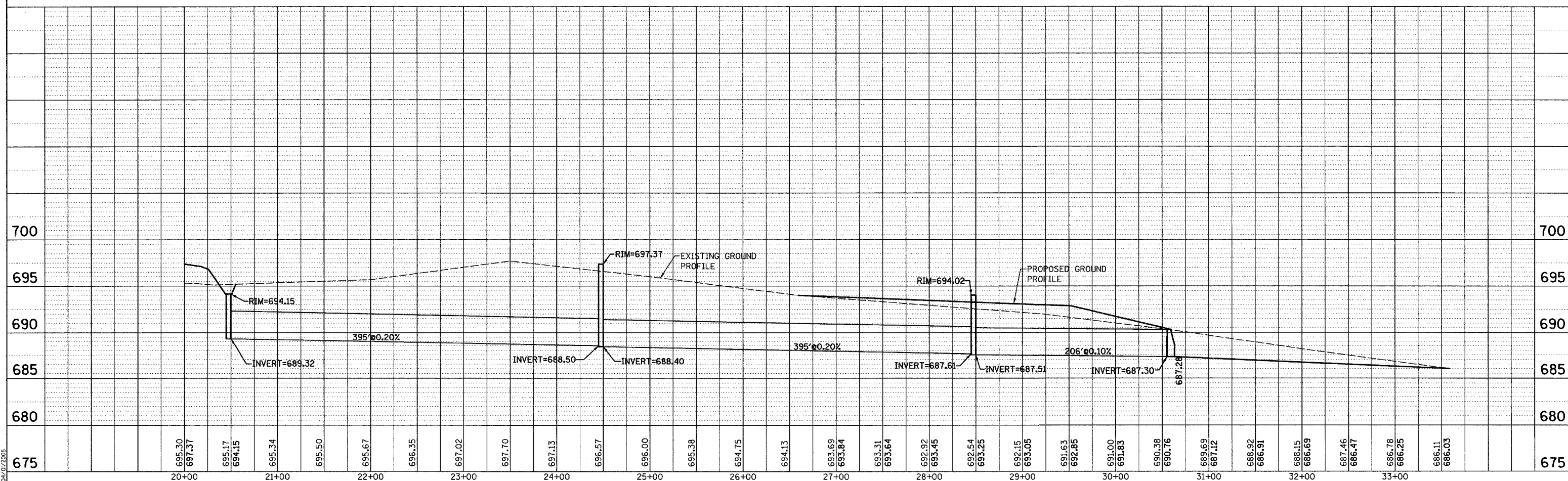
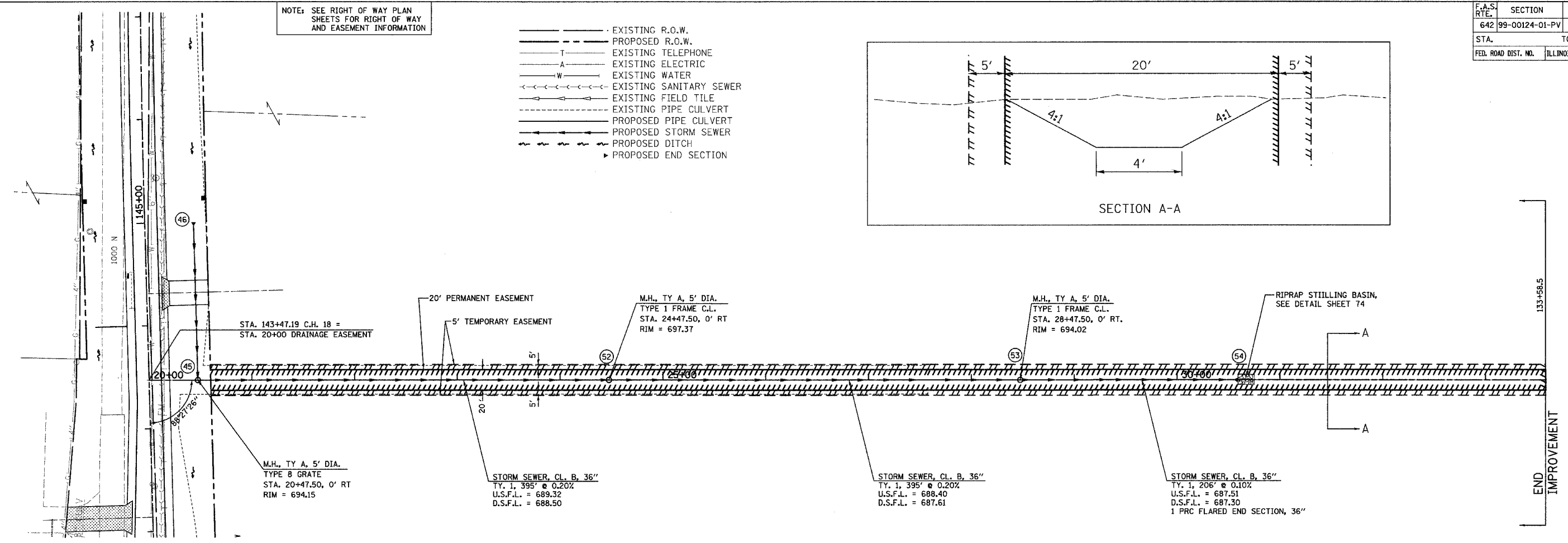
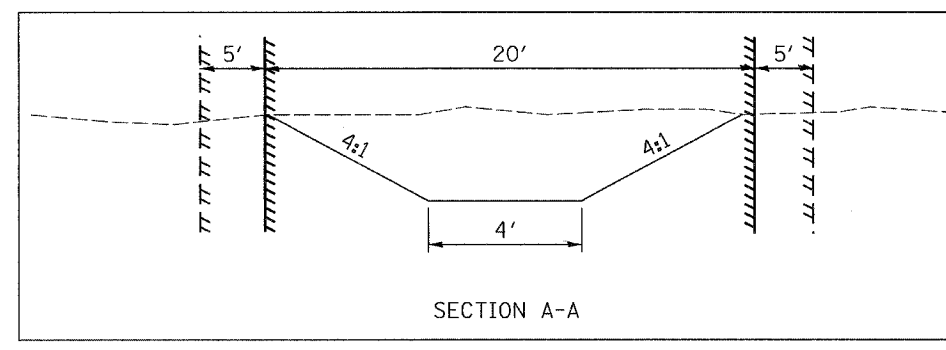

DRAWN BY: S.F.
 CHECKED BY: M.E.D.
 TUG PROJ. # 997022-5
 SHEET # 36 OF 157
 DATE: 07/20/05

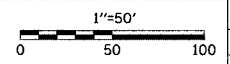

F.A.S. RTE.	SECTION	COUNTY	TOTAL SHEETS	SHEET NO.
642	99-00124-01-PV	COLES	157	37
STA. 100+00		TO STA. 126+00		
FED. ROAD DIST. NO.	ILLINOIS	FED. AID PROJECT		

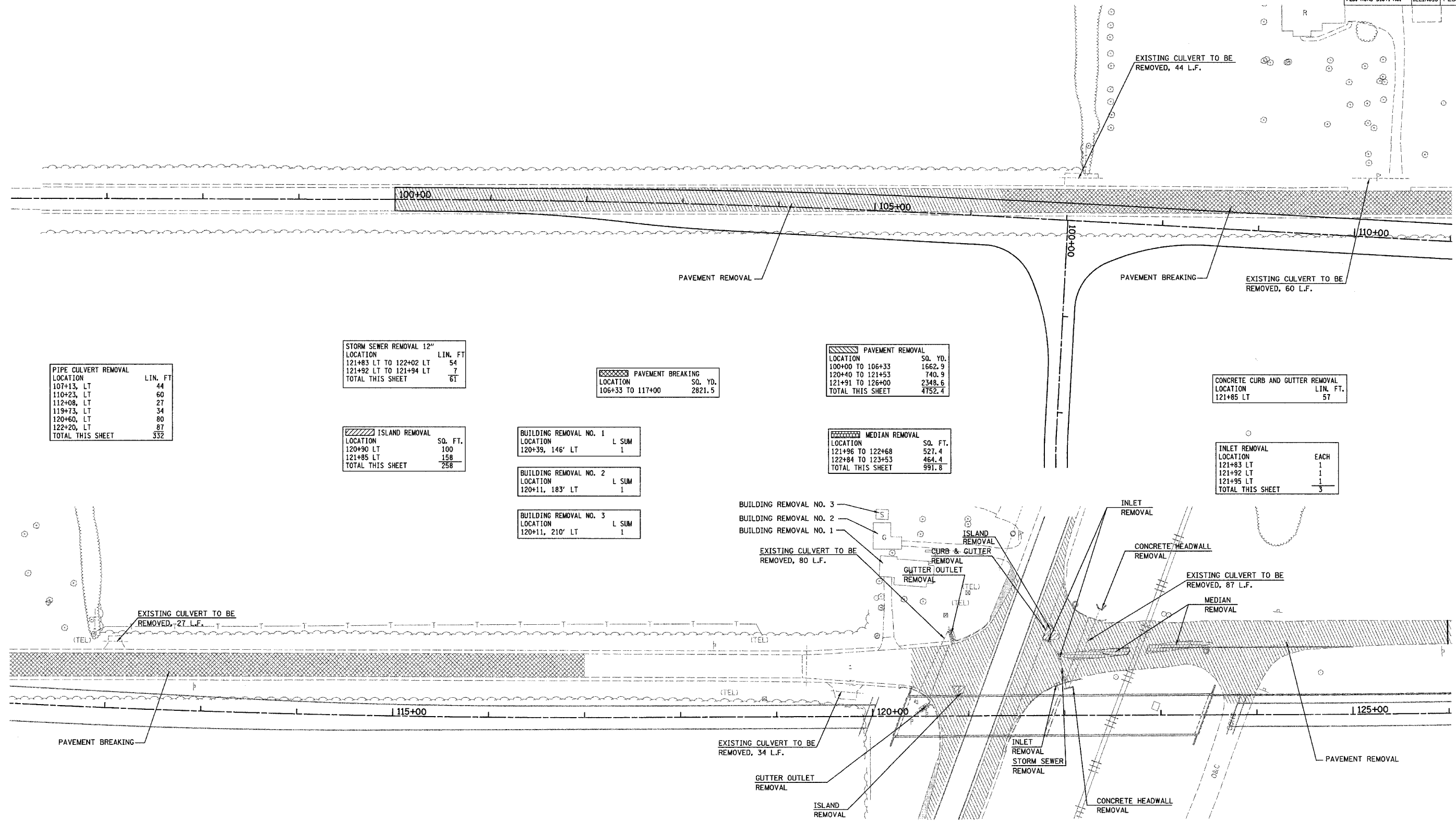

PIPE CULVERT REMOVAL	
LOCATION	LIN. FT.
107+13, LT	44
110+23, LT	60
112+08, LT	27
119+73, LT	34
120+60, LT	80
122+20, LT	87
TOTAL THIS SHEET	332

STORM SEWER REMOVAL 12"	
LOCATION	LIN. FT.
121+83 LT TO 122+02 LT	54
121+92 LT TO 121+94 LT	7
TOTAL THIS SHEET	61

PAVEMENT BREAKING	
LOCATION	SQ. YD.
106+33 TO 117+00	2821.5

PAVEMENT REMOVAL	
LOCATION	SQ. YD.
100+00 TO 106+33	1662.9
120+40 TO 121+53	740.9
121+91 TO 126+00	2348.6
TOTAL THIS SHEET	4752.4

CONCRETE CURB AND GUTTER REMOVAL	
LOCATION	LIN. FT.
121+85 LT	57

ISLAND REMOVAL	
LOCATION	SQ. FT.
120+90 LT	100
121+85 LT	158
TOTAL THIS SHEET	258

BUILDING REMOVAL NO. 1	
LOCATION	L SUM
120+39, 146' LT	1

BUILDING REMOVAL NO. 2	
LOCATION	L SUM
120+11, 183' LT	1

BUILDING REMOVAL NO. 3	
LOCATION	L SUM
120+11, 210' LT	1

MEDIAN REMOVAL	
LOCATION	SQ. FT.
121+96 TO 122+68	527.4
122+84 TO 123+53	464.4
TOTAL THIS SHEET	991.8

INLET REMOVAL	
LOCATION	EACH
121+83 LT	1
121+92 LT	1
121+95 LT	1
TOTAL THIS SHEET	3

GUTTER OUTLET REMOVAL	
LOCATION	EACH
120+56 LT	1
120+83 LT	1
TOTAL THIS SHEET	2

CONCRETE HEADWALL REMOVAL	
LOCATION	EACH
122+05 LT	1
122+37 LT	1
TOTAL THIS SHEET	2

REVISIONS	
NAME	DATE

ILLINOIS DEPARTMENT OF TRANSPORTATION

REMOVAL PLAN

SCALE: VERT. DRAWN BY RLH
 HORIZ. 1" = 50' CHECKED BY MED
 DATE 08/12/2005

TUC PROJ. #197022-5
 .. SITE REMOVAL - W.dgn
 08/12/2005

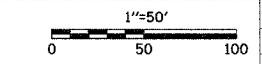

F.A.S. RTE.	SECTION	COUNTY	TOTAL SHEETS	SHEET NO.
642	99-00124-01-PV	COLES	157	38
STA. 126+00		TO STA. 156+00		
FED. ROAD DIST. NO.		ILLINOIS	FED. AID PROJECT	

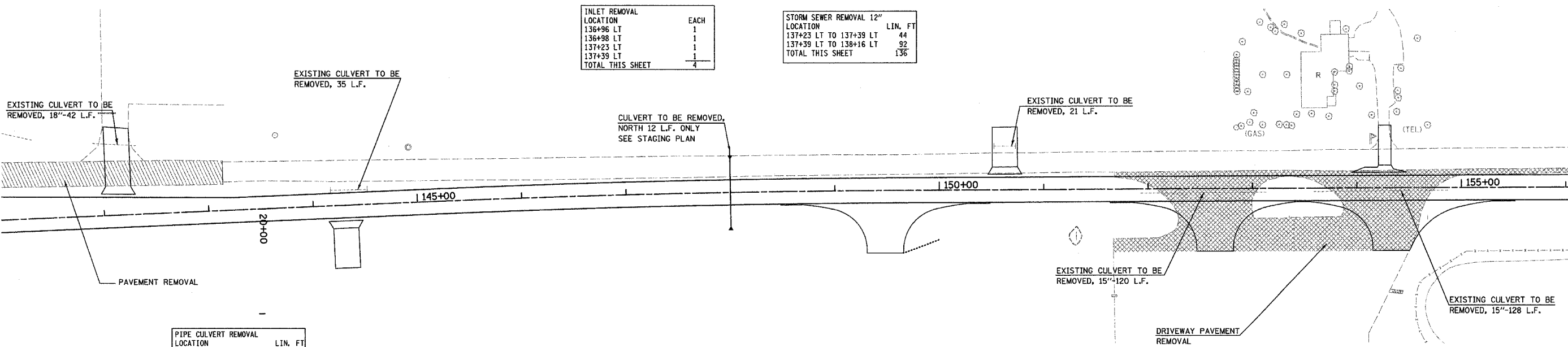
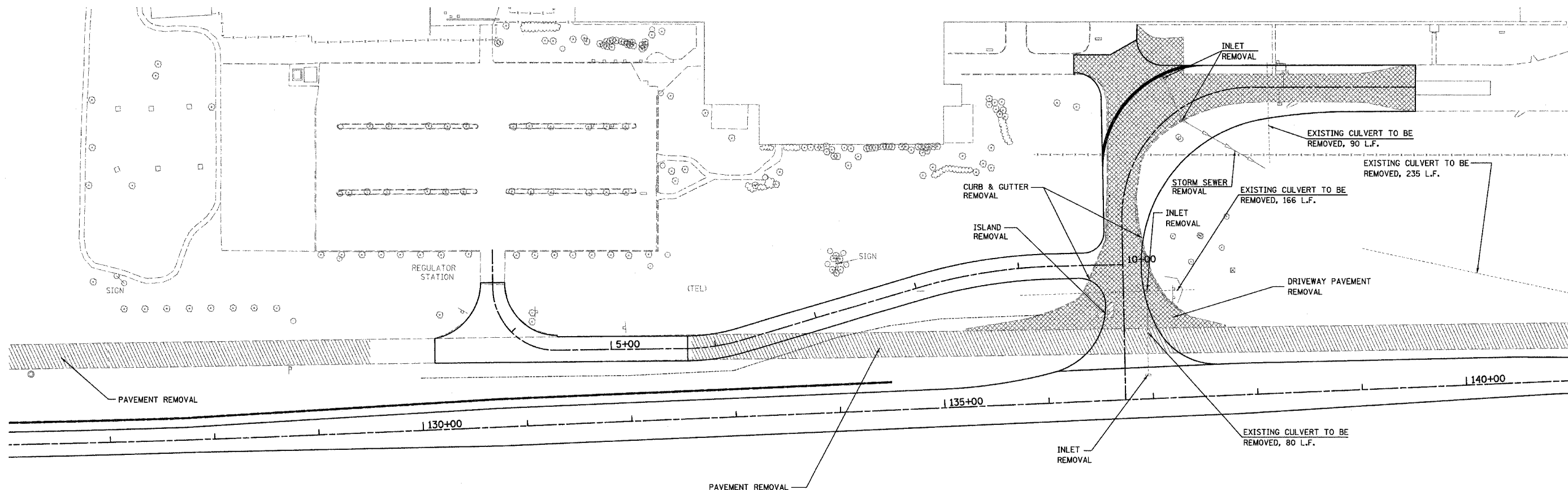

INLET REMOVAL LOCATION	EACH
136+96 LT	1
136+98 LT	1
137+23 LT	1
137+39 LT	1
TOTAL THIS SHEET	4

STORM SEWER REMOVAL 12" LOCATION	LIN. FT
137+23 LT TO 137+39 LT	44
137+39 LT TO 138+16 LT	92
TOTAL THIS SHEET	136

PIPE CULVERT REMOVAL LOCATION	LIN. FT
136+60, LT	166
136+97, LT	80
138+21, LT	90
140+20, LT	235
142+11, LT	42
144+35, LT	35
148+00, LT	12
150+63, LT	21
152+53, RT	120
154+23, RT	128
TOTAL THIS SHEET	929

CONCRETE CURB AND GUTTER REMOVAL LOCATION	LIN. FT.
135+24 LT TO 136+37 LT	353
137+72 LT TO 139+63 LT	479
137+42 LT TO 139+65 LT	222
TOTAL THIS SHEET	1054

DRIVEWAY PAVEMENT REMOVAL LOCATION	SQ. YD.
136+67.00 LT	2719.2
152+63.93 RT	993.3
154+32.48 RT	994.1
TOTAL THIS SHEET	4706.6

ISLAND REMOVAL LOCATION	SQ. FT.
136+60 LT	156.7

PAVEMENT REMOVAL LOCATION	SQ. YD.
126+00 TO 129+50	932.1
132+60 TO 143+14	2805.8
TOTAL THIS SHEET	3737.9

REVISIONS	
NAME	DATE

ILLINOIS DEPARTMENT OF TRANSPORTATION

REMOVAL PLAN

SCALE: VERT. 1" = 50'
 HORIZ. 1" = 50'
 DATE: #DATE#

DRAWN BY: RLH
 CHECKED BY: MED

TUG PROJ. #13197022-5
 @FILE:ABREV#
 @DATE#

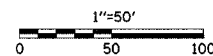

F.A.S. RTE.	SECTION	COUNTY	TOTAL SHEETS	SHEET NO.
642	99-00124-01-PV	COLES	157	39
STA. 156+00		TO STA. 171+00		
FED. ROAD DIST. NO.	ILLINOIS	FED. AID PROJECT		

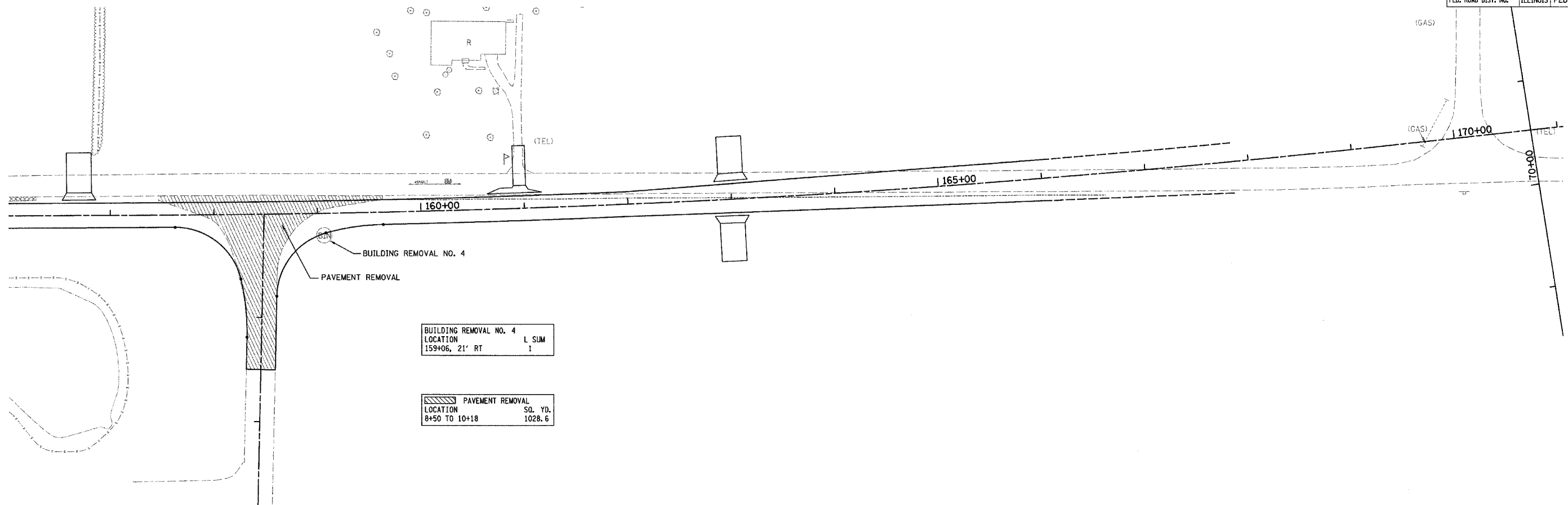

BUILDING REMOVAL NO. 4	
LOCATION	L. SUM
159+06, 21' RT	1

PAVEMENT REMOVAL	
LOCATION	SQ. YD.
8+50 TO 10+18	1028.6

REVISIONS	
NAME	DATE

ILLINOIS DEPARTMENT OF TRANSPORTATION

REMOVAL PLAN

SCALE: VERT. DRAWN BY RLH
 HORIZ. 1" = 50'
 DATE 08/12/2005 CHECKED BY MED

TUC PROJ. #1387022-5
 .. SHEET REMOVAL-W.dgn
 08/12/2005

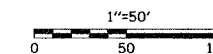

F.A.S. RTE.	SECTION	COUNTY	TOTAL SHEETS	SHEET NO.
642	99-00124-01-PV	COLES	157	40
STA. 102+50		TO STA. 132+50		
FED. ROAD DIST. NO.		ILLINOIS	FED. AID PROJECT	



CONCRETE CURB AND GUTTER REMOVAL	LOCATION	LIN. FT.
	118+93 LT TO 119+53 LT	108
	119+29 RT TO 120+27 RT	120
	120+20 LT TO 120+56 LT	51
	120+93 RT TO 121+16 RT	68
TOTAL THIS SHEET		347

PAVED SHOULDER REMOVAL	LOCATION	SQ. YD.
	117+67 LT TO 118+93 LT	91.0
	120+55 LT TO 121+12 LT	39.1
TOTAL THIS SHEET		130.1

PAVEMENT REMOVAL	LOCATION	SQ. YD.
	115+76 RT TO 119+59 RT	498.8
	116+24 LT TO 118+93 LT	122.2
	121+03 LT TO 127+25 LT	240.4
	121+32 RT TO 127+22 RT	235.0
TOTAL THIS SHEET		1096.4

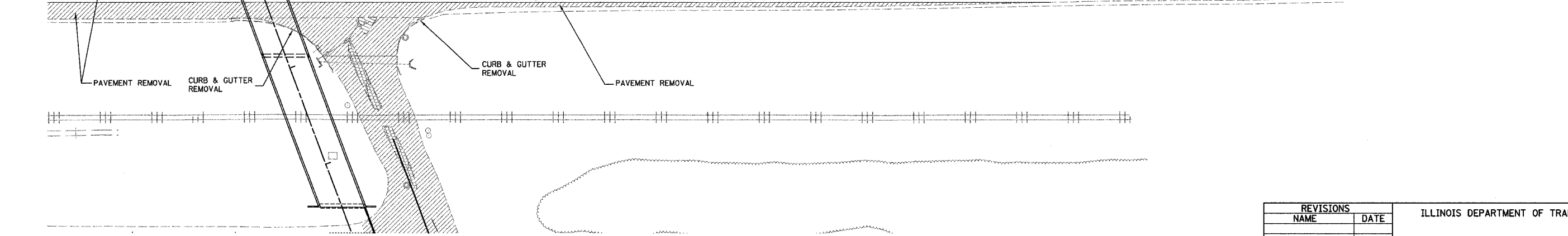
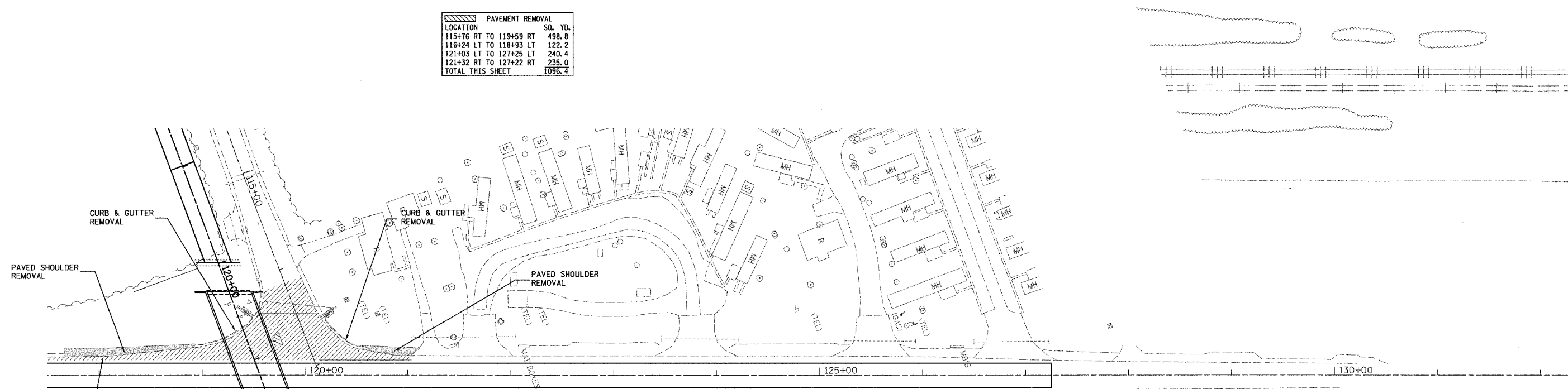
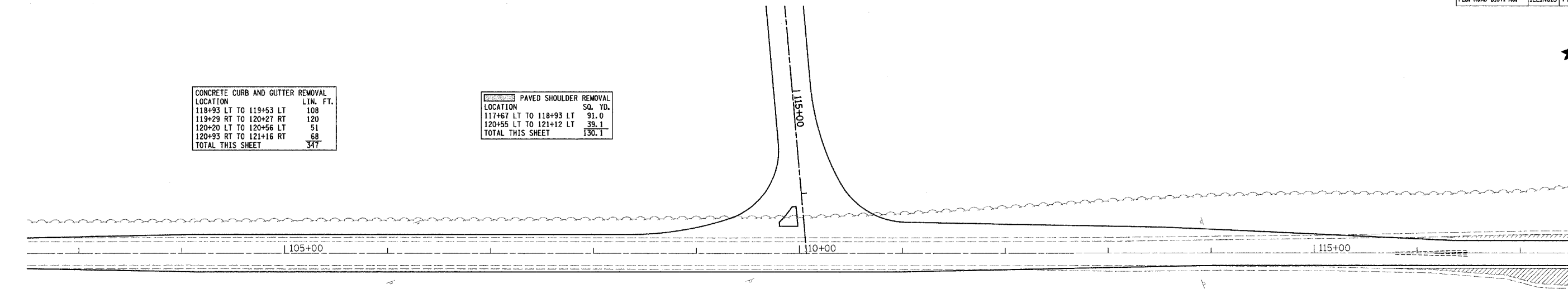

REVISIONS	
NAME	DATE

ILLINOIS DEPARTMENT OF TRANSPORTATION

REMOVAL PLAN

SCALE: VERT. 1" = 50'
 HORIZ. 1" = 50'
 DATE @DATE#

DRAWN BY RLH
 CHECKED BY MED

TUC PROJ. #1917022-5
 #FILE ABBREV#
 #DATE#

F.A.S. RTE.	SECTION	COUNTY	TOTAL SHEETS	SHEET NO.
642	99-00124-01-PV	COLES	157	41
STA. TO STA.				
FED. ROAD DIST. NO.		ILLINOIS	FED. AID PROJECT	

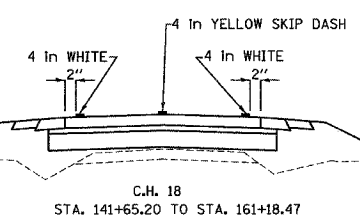
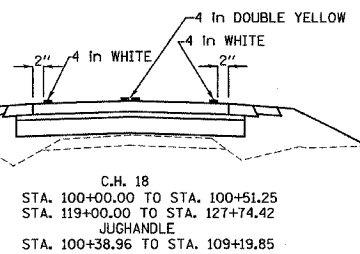
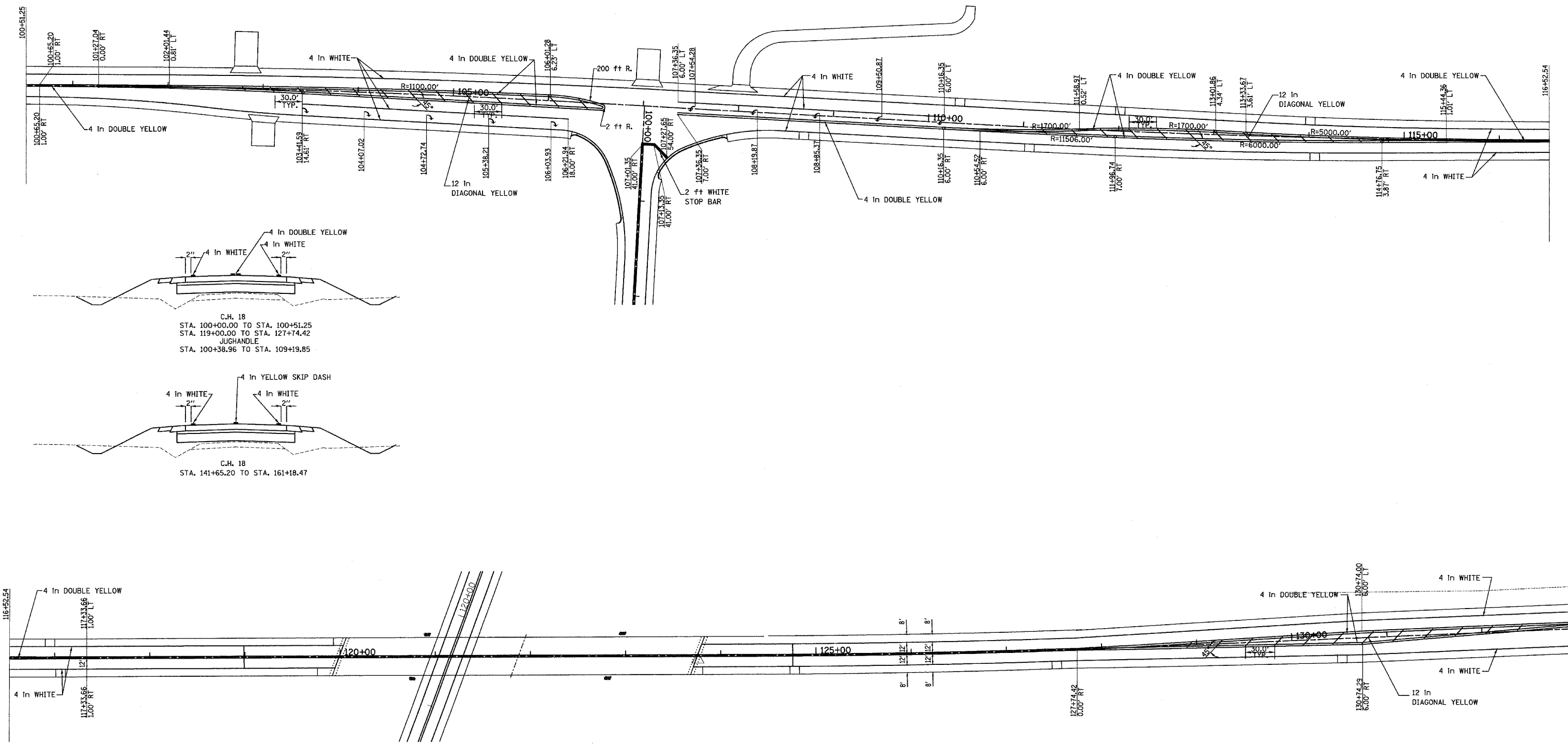

REVISIONS	
NAME	DATE

ILLINOIS DEPARTMENT OF TRANSPORTATION
PAVEMENT MARKING
C.H. 18

SCALE: VERT. 1"=50'
 HORIZ. 1"=50'
 DATE 04/01/2005

DRAWN BY RLH
 CHECKED BY MED

TUG PROJ. #3187022-5
 \SHEETPA-M.dgn
 04/01/2005

F.A.S. RTE.	SECTION	COUNTY	TOTAL SHEETS	SHEET NO.
642	99-00124-01-PV	COLES	157	42
STA. TO STA.		FED. ROAD DIST. NO. ILLINOIS FED. AID PROJECT		

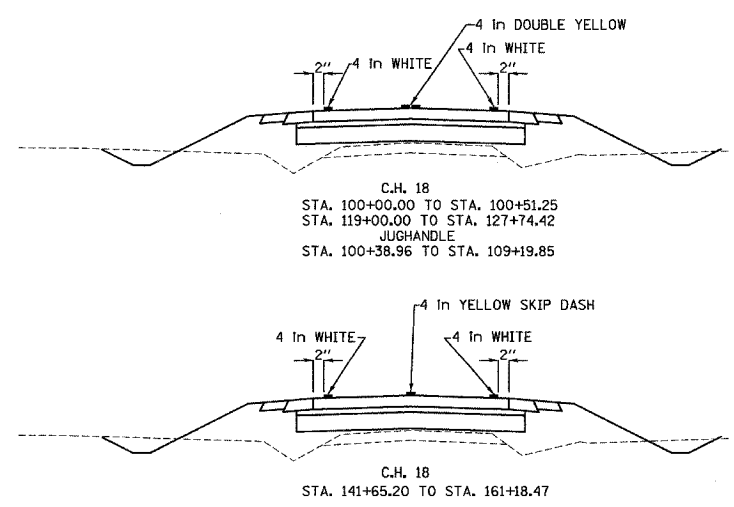
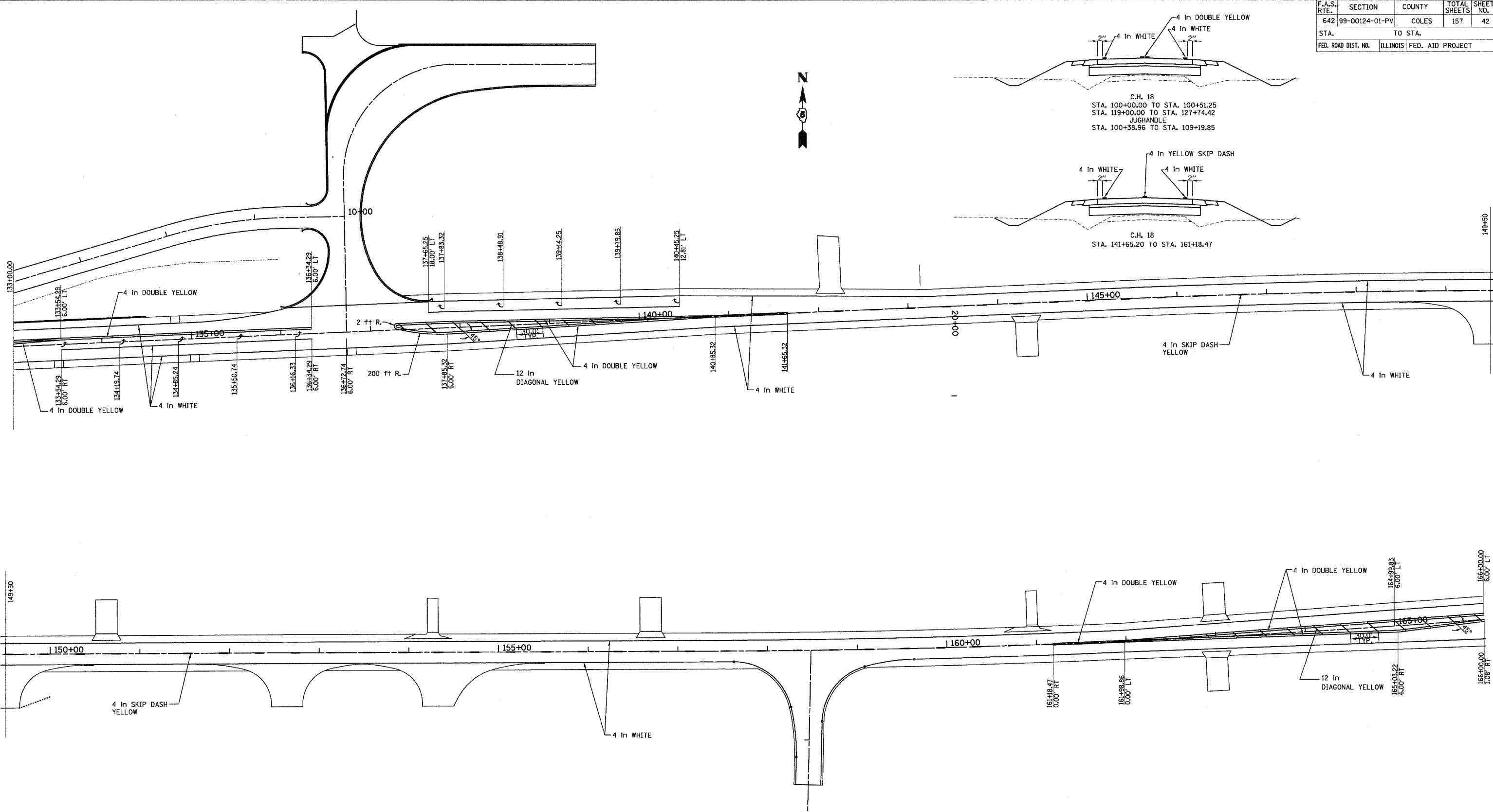

REVISIONS	
NAME	DATE

ILLINOIS DEPARTMENT OF TRANSPORTATION
PAVEMENT MARKING
C.H. 18

SCALE: VERT. 1"=50'
HORIZ. 1"=50'
DATE 04/01/2005

DRAWN BY RLH
CHECKED BY MED

TUG PROJ. #1817022-5
SHEET PA-W-591
04/01/2005

F.A.S. RTE.	SECTION	COUNTY	TOTAL SHEETS	SHEET NO.
642	99-00124-01-PV	COLES	157	43
STA.		TO STA.		
FED. ROAD DIST. NO.		ILLINOIS FED. AID PROJECT		

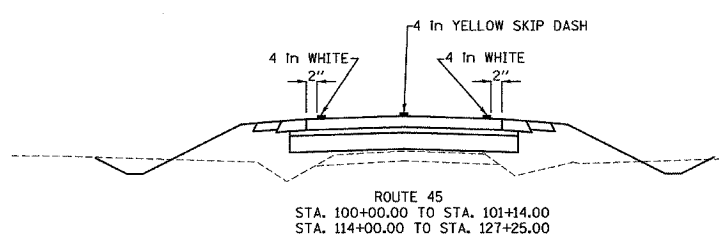
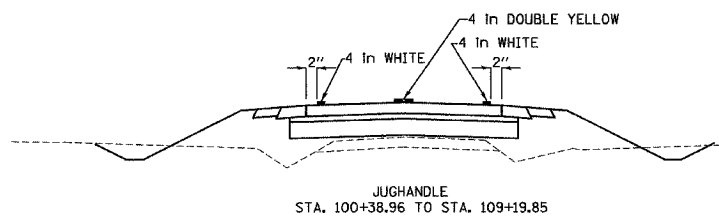
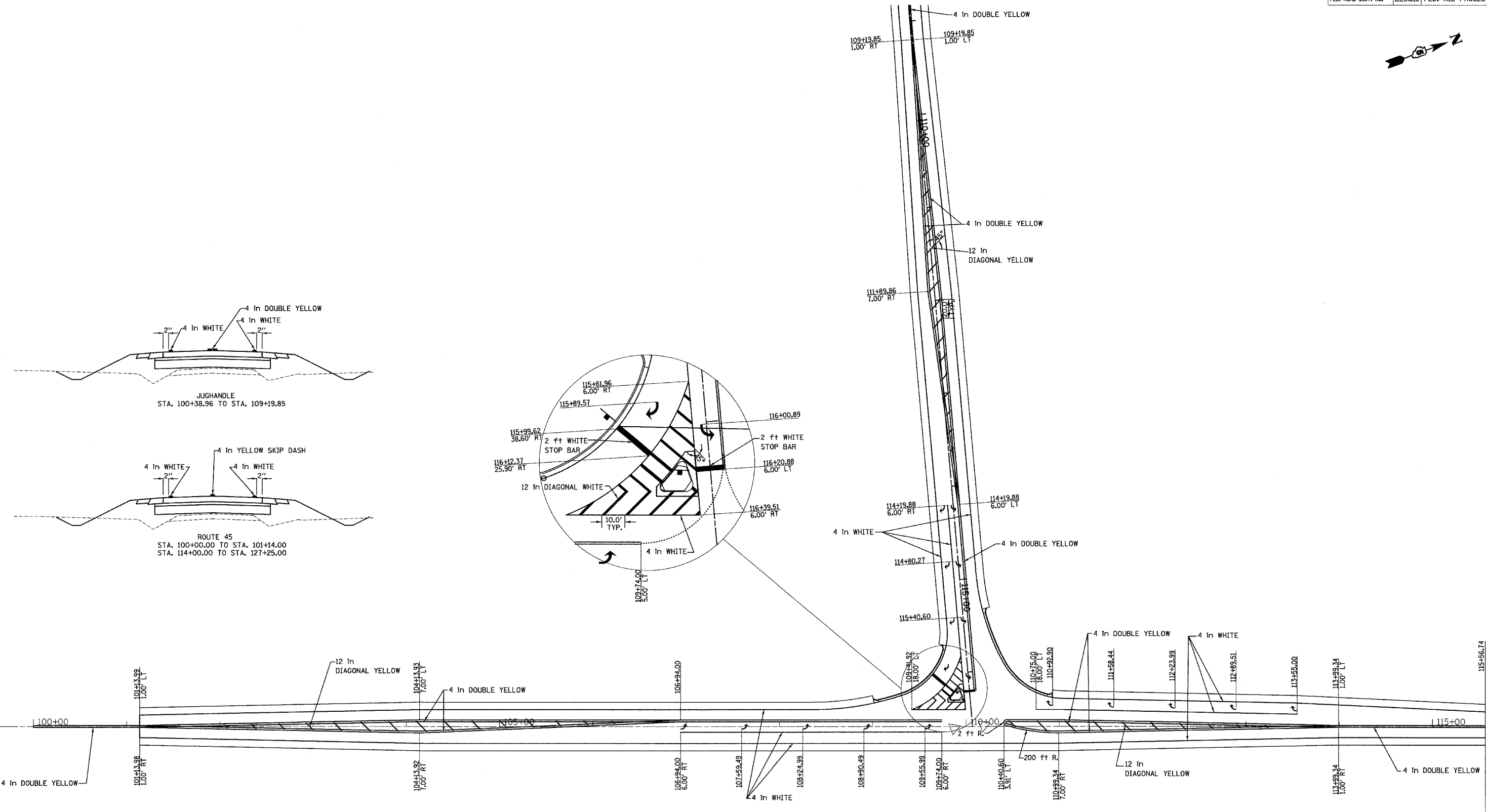

REVISIONS	
NAME	DATE

ILLINOIS DEPARTMENT OF TRANSPORTATION

PAVEMENT MARKING
U.S. RTE. 45 & JUG HANDLE

SCALE: VERT. 1"=50'
HORIZ. 1"=50'
DATE 04/01/2005

DRAWN BY RLH
CHECKED BY MED

TUC PROJ #3197022-5
SHEET # 46 of 51
04/01/2005

F.A.S. RTE.	SECTION	COUNTY	TOTAL SHEETS	SHEET NO.
642	99-00124-01-PV	COLES	157	44
STA.		TO STA.		
FED. ROAD DIST. NO.	ILLINOIS	FED. AID PROJECT		

EPOXY PAVEMENT MARKING-LINE 4"				
LOCATION	COLOR	DESCRIPTION	LIN. FT.	
100+00.00 TO 102+01.44	YELLOW	SKIP-DASH	402.9	
100+00.00 RT TO 100+60.90 RT	WHITE	EDGE LINE	60.8	
100+00.00 LT TO 107+33.11 LT	WHITE	EDGE LINE	733.9	
100+65.20 LT TO 102+01.44 LT	YELLOW	DOUBLE LINE	272.4	
101+27.04 RT TO 103+41.88 RT	YELLOW	DOUBLE LINE	429.8	
102+01.44 LT TO 106+01.29 LT	YELLOW	DOUBLE LINE	800.0	
100+60.90 RT TO 102+40.35 RT	WHITE	EDGE LINE	179.5	
102+40.35 RT TO 103+41.30 RT	WHITE	EDGE LINE	100.9	
103+41.59 RT TO 106+21.94 RT	WHITE	TURN LANE	280.0	
103+41.30 RT TO 106+16.34 RT	WHITE	EDGE LINE	274.4	
103+41.88 RT TO 106+58.66 RT	YELLOW	DOUBLE LINE	635.2	
106+01.29 LT TO 106+58.66 RT	YELLOW	DOUBLE LINE	119.0	
107+33.58 LT TO 113+33.93 LT	WHITE	EDGE LINE	600.0	
107+36.35 RT TO 110+16.35 RT	WHITE	TURN LANE	280.0	
107+36.35 RT TO 110+54.52 RT	YELLOW	DOUBLE LINE	636.4	
108+44.48 RT TO 117+33.66 RT	WHITE	EDGE LINE	890.1	
110+16.35 RT TO 111+59.05 RT	YELLOW	DOUBLE LINE	285.8	
110+54.52 RT TO 111+96.74 RT	YELLOW	DOUBLE LINE	284.6	
111+59.05 RT TO 113+01.85 LT	YELLOW	DOUBLE LINE	285.8	
111+96.74 RT TO 114+76.72 RT	YELLOW	DOUBLE LINE	560.2	
113+01.84 RT TO 115+44.36 LT	YELLOW	DOUBLE LINE	485.0	
113+33.93 LT TO 117+33.66 RT	WHITE	EDGE LINE	399.3	
114+76.72 RT TO 117+33.66 RT	YELLOW	DOUBLE LINE	514.0	
115+44.36 LT TO 117+33.66 RT	YELLOW	DOUBLE LINE	378.6	
127+74.53 RT TO 130+74.29 RT	YELLOW	DOUBLE LINE	600.2	
127+74.42 LT TO 130+74.00 LT	YELLOW	DOUBLE LINE	599.2	
127+74.29 RT TO 137+85.32 RT	WHITE	EDGE LINE	1011.2	
127+74.29 LT TO 135+00.20 LT	WHITE	EDGE LINE	725.8	
130+74.29 RT TO 133+54.29 LT	YELLOW	DOUBLE LINE	560.6	
130+74.00 LT TO 133+54.29 LT	YELLOW	DOUBLE LINE	560.6	
133+54.29 LT TO 136+34.29 LT	YELLOW	DOUBLE LINE	560.0	
133+54.29 RT TO 136+34.29 RT	WHITE	TURN LANE	280.0	
137+27.63 LT TO 140+85.32 RT	YELLOW	DOUBLE LINE	717.4	
137+27.63 RT TO 137+85.32 RT	YELLOW	DOUBLE LINE	119.8	
137+85.32 RT TO 141+65.20 RT	YELLOW	DOUBLE LINE	760.0	
137+65.25 LT TO 140+45.25 LT	WHITE	TURN LANE	280.0	
137+65.25 LT TO 141+65.20 LT	WHITE	EDGE LINE	400.1	
137+85.32 RT TO 141+65.20 RT	WHITE	EDGE LINE	379.9	
161+18.47 RT TO 166+00.00 RT	WHITE	EDGE LINE	401.5	
161+18.47 LT TO 166+00.00 LT	WHITE	EDGE LINE	401.5	
161+18.47 RT TO 162+01.24 RT	YELLOW	DOUBLE LINE	160.0	
162+01.24 RT TO 165+03.22 RT	YELLOW	DOUBLE LINE	604.2	
161+98.86 LT TO 164+99.83 LT	YELLOW	DOUBLE LINE	601.8	
164+99.83 LT TO 166+00.00 LT	YELLOW	DOUBLE LINE	200.4	
165+03.22 RT TO 166+00.00 RT	YELLOW	DOUBLE LINE	193.8	
JUGHANDLE				
109+19.88 LT TO 115+33.59 LT	WHITE	EDGE LINE	614.1	
109+19.88 RT TO 115+69.79 RT	WHITE	EDGE LINE	650.4	
109+19.88 RT TO 111+89.88 RT	YELLOW	DOUBLE LINE	540.2	
109+19.88 LT TO 116+19.88 LT	YELLOW	DOUBLE LINE	1400.4	
111+89.88 RT TO 114+19.88 LT	YELLOW	DOUBLE LINE	460.8	
114+19.88 RT TO 115+81.96 RT	WHITE	TURN LANE	162.1	
115+81.96 RT TO 116+39.51 RT	WHITE	ISLAND	195.8	
TOTAL			24030.4	

EPOXY PAVEMENT MARKING-LINE 12"				
LOCATION	COLOR	DESCRIPTION	LIN. FT.	
C.H. 18				
102+78.34 TO 106+41.31	YELLOW	DIAGONAL	143.2	
111+21.12 TO 114+83.90	YELLOW	DIAGONAL	120.4	
128+89.75 TO 132+42.40	YELLOW	DIAGONAL	141.5	
137+32.10 TO 140+09.61	YELLOW	DIAGONAL	122.3	
161+98.47 TO 166+00.00	YELLOW	DIAGONAL	130.5	
JUGHANDLE				
110+03.11 TO 113+61.96	YELLOW	DIAGONAL	199.2	
115+81.96 RT TO 116+39.51 RT	WHITE	DIAGONAL	154.1	
TOTAL			1011.2	

EPOXY PAVEMENT MARKING-LINE 24"				
LOCATION	COLOR	DESCRIPTION	LIN. FT.	
JUGHANDLE				
100+39.00 LT	WHITE	STOP BAR	32.9	
116+10.95 RT	WHITE	STOP BAR	18.0	
116+18.88	WHITE	STOP BAR	12.0	
TOTAL			62.9	

EPOXY PAVEMENT MARKING - LETTERS & SYMBOLS				
LOCATION	COLOR	DESCRIPTION	SQ. FT.	
C.H. 18				
103+41.59 RT	WHITE	RIGHT TURN ARROW	15.6	
104+07.02 RT	WHITE	RIGHT TURN ARROW	15.6	
104+72.74 RT	WHITE	RIGHT TURN ARROW	15.6	
105+38.21 RT	WHITE	RIGHT TURN ARROW	15.6	
106+03.93 RT	WHITE	RIGHT TURN ARROW	15.6	
107+54.28	WHITE	LEFT TURN ARROW	15.6	
108+19.87	WHITE	LEFT TURN ARROW	15.6	
108+85.37	WHITE	LEFT TURN ARROW	15.6	
109+50.87	WHITE	LEFT TURN ARROW	15.6	
110+16.35	WHITE	LEFT TURN ARROW	15.6	
133+54.29	WHITE	LEFT TURN ARROW	15.6	
134+19.74	WHITE	LEFT TURN ARROW	15.6	
134+85.24	WHITE	LEFT TURN ARROW	15.6	
135+50.74	WHITE	LEFT TURN ARROW	15.6	
136+16.33	WHITE	LEFT TURN ARROW	15.6	
137+83.32 LT	WHITE	RIGHT TURN ARROW	15.6	
138+48.91 LT	WHITE	RIGHT TURN ARROW	15.6	
139+14.25 LT	WHITE	RIGHT TURN ARROW	15.6	
139+79.85 LT	WHITE	RIGHT TURN ARROW	15.6	
140+45.25 LT	WHITE	RIGHT TURN ARROW	15.6	
JUGHANDLE				
114+19.88 RT	WHITE	RIGHT TURN ARROW	15.6	
114+19.88	WHITE	LEFT TURN ARROW	15.6	
114+80.27 RT	WHITE	RIGHT TURN ARROW	15.6	
114+80.27	WHITE	LEFT TURN ARROW	15.6	
115+40.60 RT	WHITE	RIGHT TURN ARROW	15.6	
115+40.60	WHITE	LEFT TURN ARROW	15.6	
115+89.57 RT	WHITE	RIGHT TURN ARROW	15.6	
116+00.89	WHITE	LEFT TURN ARROW	15.6	
TOTAL			436.8	

THERMOPLASTIC PAVEMENT MARKING-LINE, 12"				
LOCATION	COLOR	DESCRIPTION	LIN. FT.	
IL 45				
102+04.48 TO 106+23.32	YELLOW	DIAGONAL	155.2	
110+46.10 TO 113+23.61	YELLOW	DIAGONAL	108.2	
TOTAL			263.4	

THERMOPLASTIC PAVEMENT MARKING-LINE 4"				
LOCATION	COLOR	DESCRIPTION	LIN. FT.	
IL 45				
100+00.00 TO 101+14.00	YELLOW	DOUBLE LINE	228.0	
101+14.00 RT TO 114+00.00 RT	WHITE	EDGE LINE	1285.6	
101+14.00 LT TO 109+01.55 LT	WHITE	EDGE LINE	788.3	
101+14.00 RT TO 104+14.00 RT	YELLOW	DOUBLE LINE	600.2	
101+14.00 LT TO 109+74.00 LT	YELLOW	DOUBLE LINE	1720.4	
104+14.00 RT TO 106+94.00 LT	YELLOW	DOUBLE LINE	560.6	
106+94.00 RT TO 109+74.00 RT	WHITE	TURN LANE	280.0	
110+75.00 LT TO 113+55.00 LT	WHITE	TURN LANE	280.2	
110+91.77 LT TO 114+00.00 LT	WHITE	EDGE LINE	309.3	
110+40.62 LT TO 110+99.32 LT	YELLOW	DOUBLE LINE	117.4	
110+40.62 LT TO 110+99.32 RT	YELLOW	DOUBLE LINE	120.0	
110+99.32 LT TO 114+00.00 LT	YELLOW	DOUBLE LINE	600.2	
110+99.32 RT TO 114+00.00 RT	YELLOW	DOUBLE LINE	600.2	
114+00.00 RT TO 127+25.00 RT	WHITE	EDGE LINE	1325.7	
114+00.00 LT TO 127+25.00 LT	WHITE	EDGE LINE	1325.0	
114+00.00 RT TO 127+25.00 RT	YELLOW	DOUBLE LINE	2650.0	
TOTAL			12791.1	

THERMOPLASTIC PAVEMENT MARKING, LETTERS & SYMBOLS				
LOCATION	COLOR	DESCRIPTION	SQ. FT.	
US 45				
106+94.00 RT	WHITE	LEFT TURN ARROW	15.6	
107+59.49 RT	WHITE	LEFT TURN ARROW	15.6	
108+24.99 RT	WHITE	LEFT TURN ARROW	15.6	
108+90.49 RT	WHITE	LEFT TURN ARROW	15.6	
109+55.99 RT	WHITE	LEFT TURN ARROW	15.6	
110+92.90 LT	WHITE	RIGHT TURN ARROW	15.6	
111+58.44 LT	WHITE	RIGHT TURN ARROW	15.6	
112+23.99 LT	WHITE	RIGHT TURN ARROW	15.6	
112+89.51 LT	WHITE	RIGHT TURN ARROW	15.6	
113+55.00 LT	WHITE	RIGHT TURN ARROW	15.6	
TOTAL			156.0	

PAINT PAVEMENT MARKING-LINE, 4"				
LOCATION	COLOR	DESCRIPTION	LIN. FT.	
C.H. 18				
117+33.66 TO 127+74.42	YELLOW	DOUBLE LINE	2081.5	
117+33.66 LT TO 127+74.42 LT	WHITE	EDGE LINE	1040.8	
117+33.66 RT TO 127+74.42 RT	WHITE	EDGE LINE	1040.8	
141+65.20 RT TO 157+52.43 RT	WHITE	EDGE LINE	1587.2	
141+65.20 LT TO 143+25.00 LT	WHITE	EDGE LINE	160.0	
143+25.00 LT TO 161+18.47 LT	WHITE	EDGE LINE	1793.5	
159+63.37 RT TO 161+18.47 RT	WHITE	EDGE LINE	155.1	
140+85.32 RT TO 161+18.47 RT	YELLOW	SKIP-DASH	490.0	
JUGHANDLE				
100+38.96 TO 109+19.88	YELLOW	DOUBLE LINE	1762.0	
100+73.94 LT TO 109+19.88 LT	WHITE	EDGE LINE	831.4	
101+23.01 RT TO 109+19.88 RT	WHITE	EDGE LINE	812.3	
TOTAL			11754.6	

SHORT TERM PAVEMENT MARKING, 4"					
LOCATION	COLOR	DESCRIPTION	LIN. FT.	FOLLOWING	
RTE 45					
111+25 TO 127+50	YELLOW	CENTER LINE	170	PAVEMENT MARKING REMOVAL	
100+00 TO 109+74	YELLOW	CENTER LINE	100	SURFACE COURSE	
106+94 RT TO 109+74 RT	WHITE	TURN LANE	30	SURFACE COURSE	
110+40 TO 127+25	YELLOW	CENTER LINE	170	SURFACE COURSE	
110+75 LT TO 113+55 LT	WHITE	TURN LANE	30	SURFACE COURSE	
TOTAL			500		

TEMPORARY PAVEMENT MARKING, 4"					
LOCATION	COLOR	DESCRIPTION	LIN. FT.	FOLLOWING	
RTE 45					
111+25 TO 127+50	YELLOW	CENTER LINE	425	PAVEMENT MARKING REMOVAL	
111+25 TO 127+50	WHITE	RIGHT EDGE LINE	1625	PAVEMENT MARKING REMOVAL	
111+25 TO 127+50	WHITE	LEFT EDGE LINE	1625	PAVEMENT MARKING REMOVAL	
100+00 TO 109+74	YELLOW	CENTER LINE	250	SURFACE COURSE	
106+94 RT TO 109+74 RT	WHITE	TURN LANE	75	SURFACE COURSE	
110+40 TO 127+25	YELLOW	CENTER LINE	425	SURFACE COURSE	
110+75 LT TO 113+55 LT	WHITE	TURN LANE	75	SURFACE COURSE	
CH 18					
121+75 TO 125+00	YELLOW	CENTER LINE	100	RR CROSSING RELOCATION	
121+75 TO 125+00	WHITE	RIGHT EDGE LINE	325	RR CROSSING RELOCATION	
TOTAL			4925		

REVISIONS		ILLINOIS DEPARTMENT OF TRANSPORTATION
NAME	DATE	
		<p align="center">PAVEMENT MARKING SCHEDULES</p> <p>SCALE: VERT. DRAWN BY RLH HORIZ. CHECKED BY MED DATE 04/01/2005</p>

TUC PROJ #101022-5
 \SHEETPA-W.dgn
 04/01/2005

F.A.S. RTE.	SECTION	COUNTY	TOTAL SHEETS	SHEET NO.
642	99-00124-01-PV	COLES	157	45
STA.		TO STA.		
FED. ROAD DIST. NO.		ILLINOIS		FED. AID PROJECT

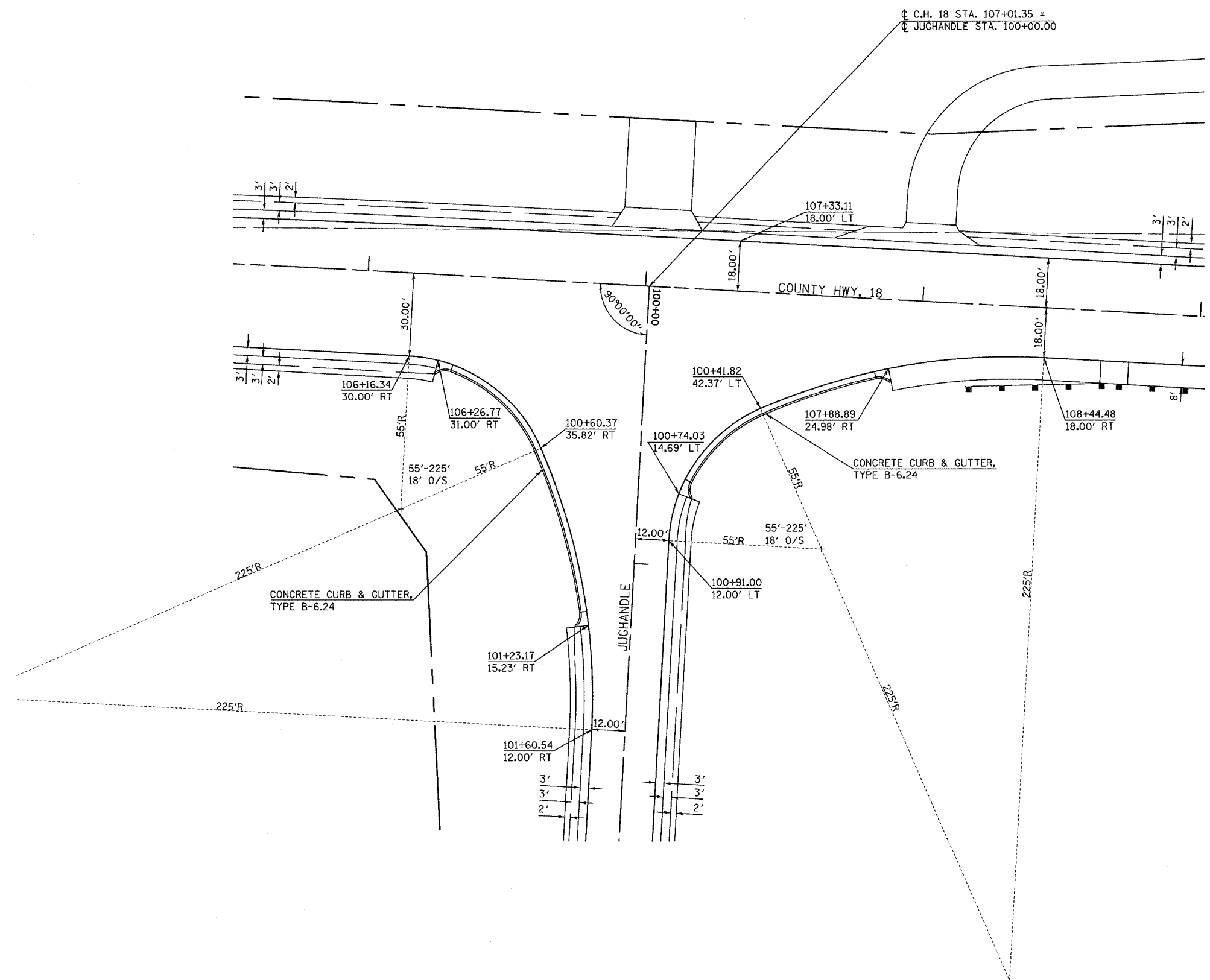

SEE SHEET 48 FOR CURB & GUTTER PROFILES

REVISIONS	
NAME	DATE

ILLINOIS DEPARTMENT OF TRANSPORTATION

**INTERSECTION DETAIL
F.A.S. RTE. 642 & JUG HANDLE**

SCALE: VERT. 1"=20'
HORIZ. 1"=20'
DATE 04/01/2005

DRAWN BY RLH
CHECKED BY MED

TUG PROJ. #1917022-5
SHEET #K-491
04/01/2005

F.A.S. RTE.	SECTION	COUNTY	TOTAL SHEETS	SHEET NO.
642	99-00124-01-PV	COLES	157	46
STA.		TO STA.		
FED. ROAD DIST. NO.		ILLINOIS FED. AID PROJECT		

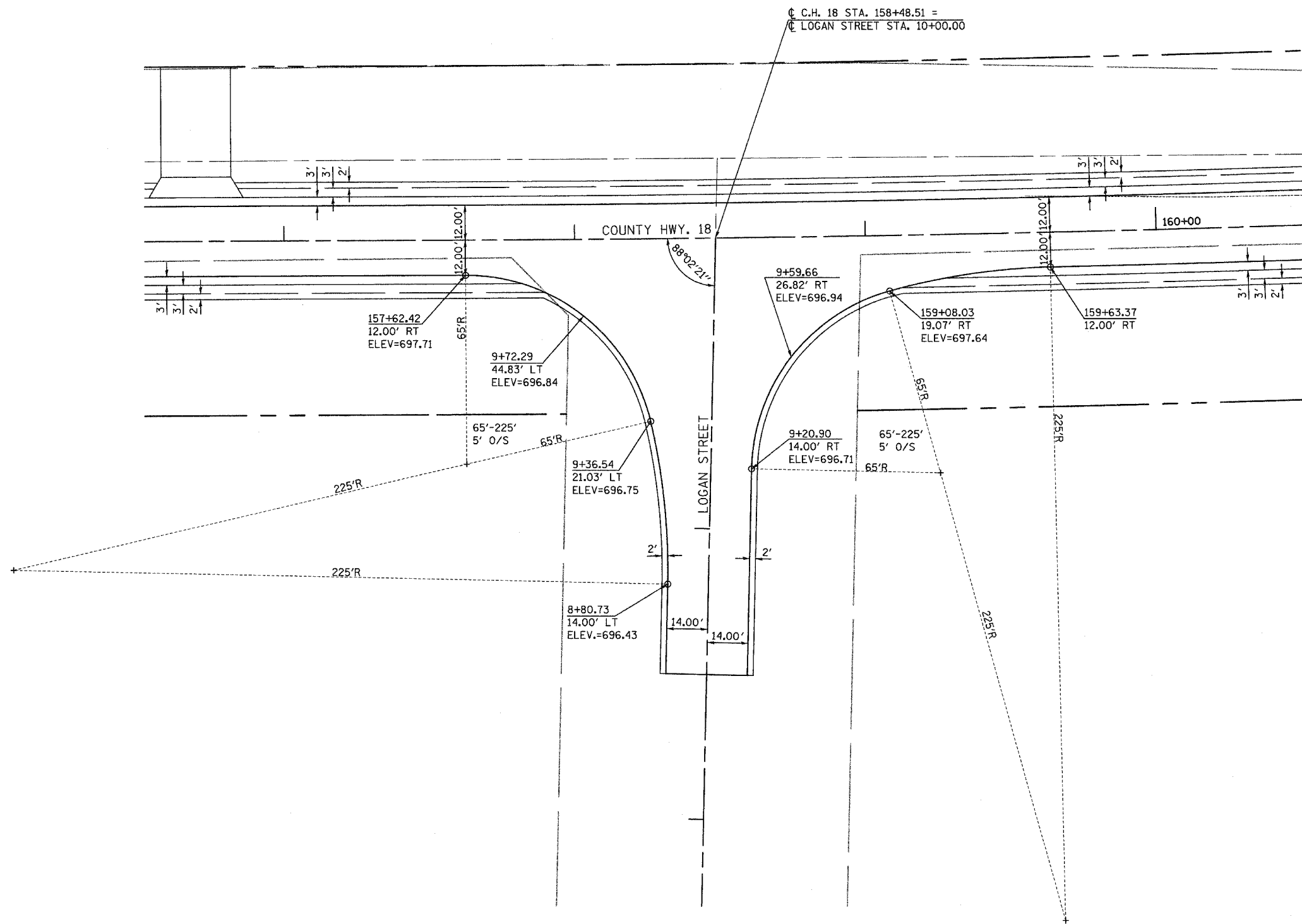

REVISIONS	
NAME	DATE

ILLINOIS DEPARTMENT OF TRANSPORTATION

INTERSECTION DETAIL
F.A.S. RTE. 642 & LOGAN STREET

SCALE: VERT. 1"=20'
 HORIZ. 1"=20'
 DATE 04/01/2005

DRAWN BY RLH
 CHECKED BY MED

TUC PROJ #3197022-5
 -1- SHEET 1 of 46
 04/01/2005

F.A.S. RTE.	SECTION	COUNTY	TOTAL SHEETS	SHEET NO.
642	99-00124-01-PV	COLES	157	47
STA. TO STA.				
FED. ROAD DIST. NO.		ILLINOIS	FED. AID PROJECT	



SEE SHEET 48 FOR CURB & GUTTER PROFILES

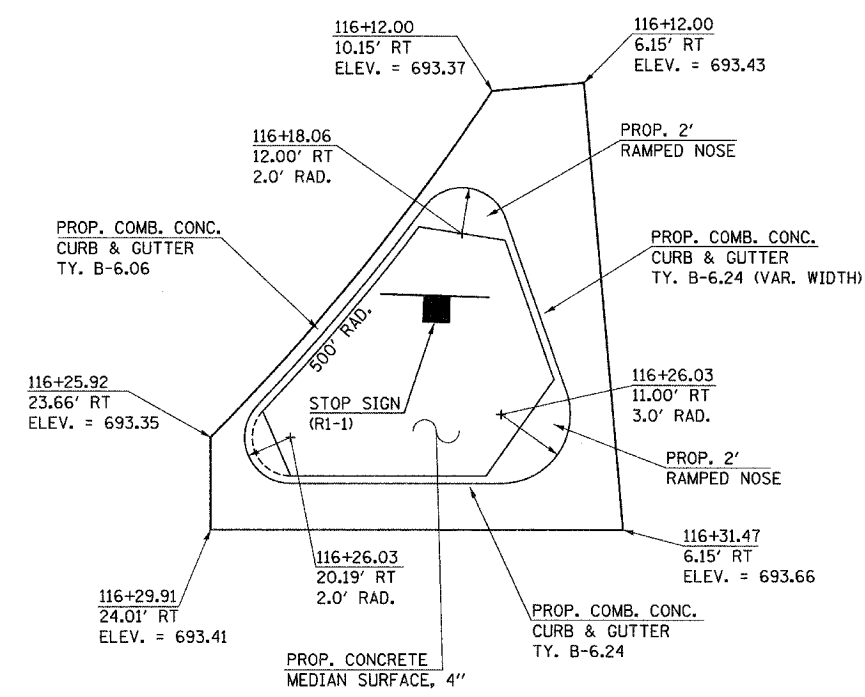
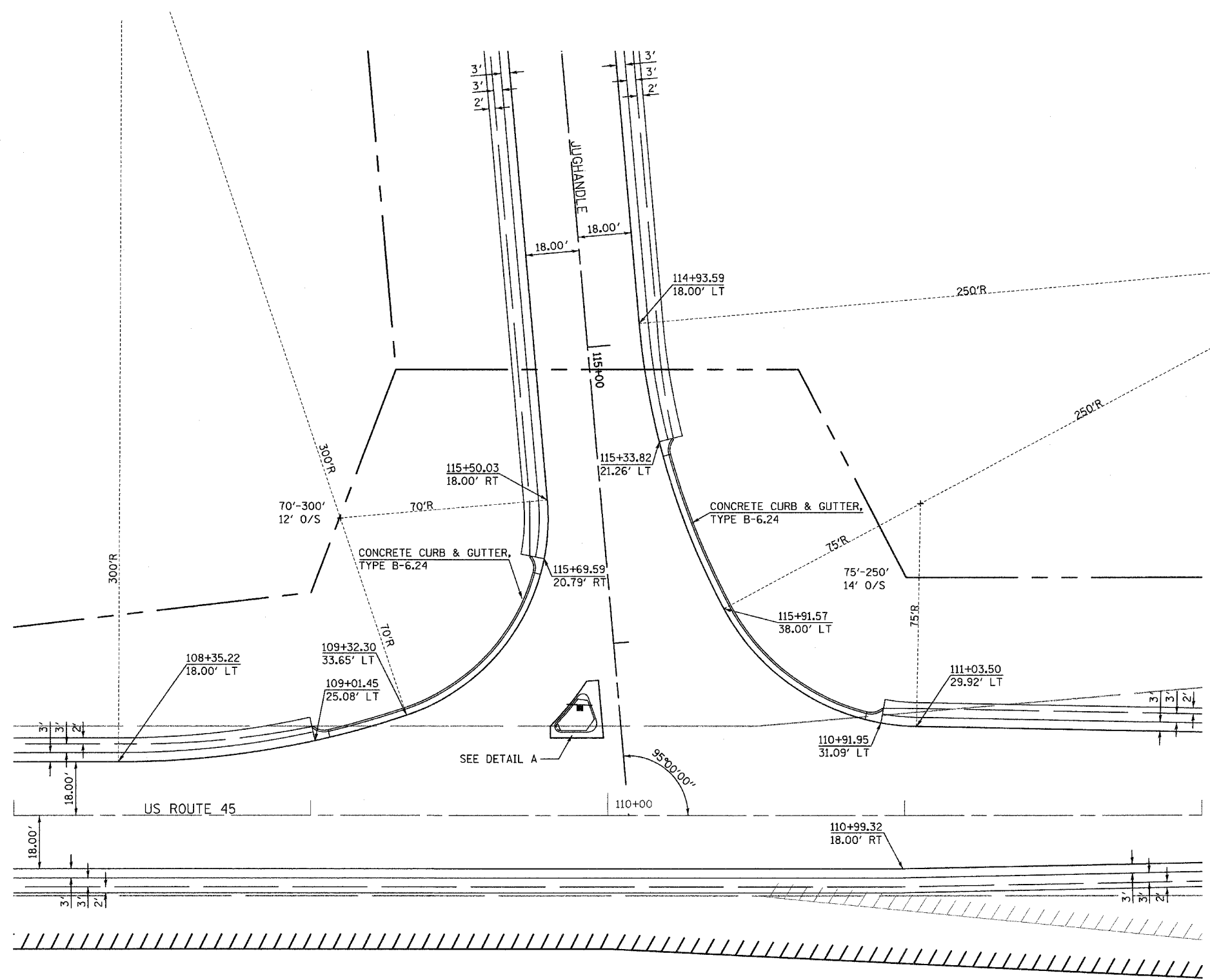

DETAIL A

REVISIONS	
NAME	DATE

ILLINOIS DEPARTMENT OF TRANSPORTATION

**INTERSECTION DETAIL
U.S. RTE. 45 & JUG HANDLE**

SCALE: VERT. 1"=20'
HORIZ. 1"=20'
DATE 04/01/2005

DRAWN BY RLH
CHECKED BY MED

TUC PROJ. #3197022-5
SHEET #1-W-491
04/01/2005

F.A.S. RTE.	SECTION	COUNTY	TOTAL SHEETS	SHEET NO.
642	99-00124-01-PV	COLES	157	48
STA.		TO STA.		
FED. ROAD DIST. NO.		ILLINOIS	FED. AID PROJECT	

**SOUTHWEST QUADRANT
OF INTERSECTION
C.H. 18 & JUGHANDLE**

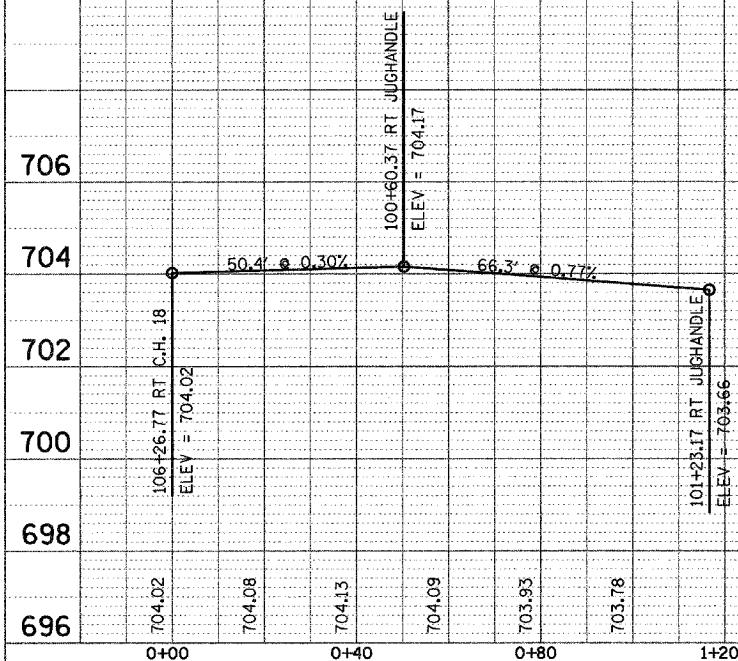

**SOUTHEAST QUADRANT
OF INTERSECTION
C.H. 18 & JUGHANDLE**

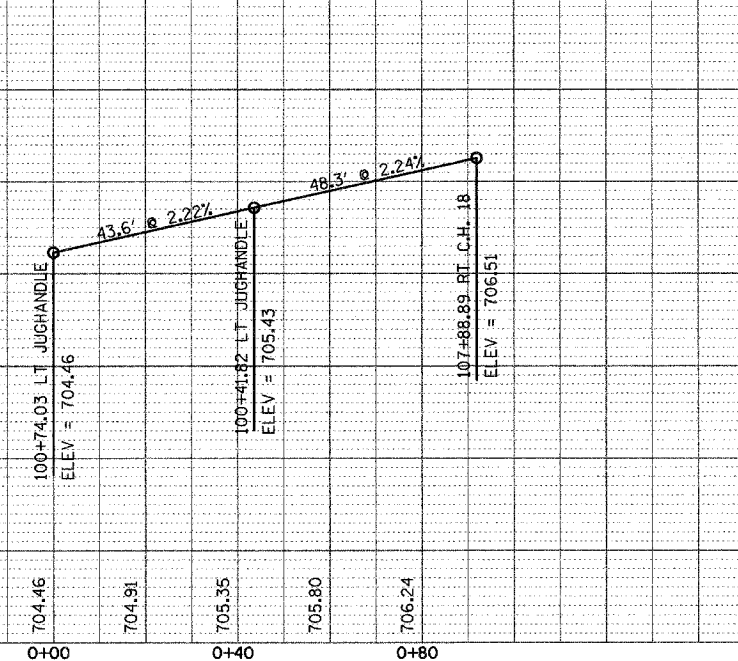

**SOUTHWEST QUADRANT
OF INTERSECTION
US RT 45 & JUGHANDLE**

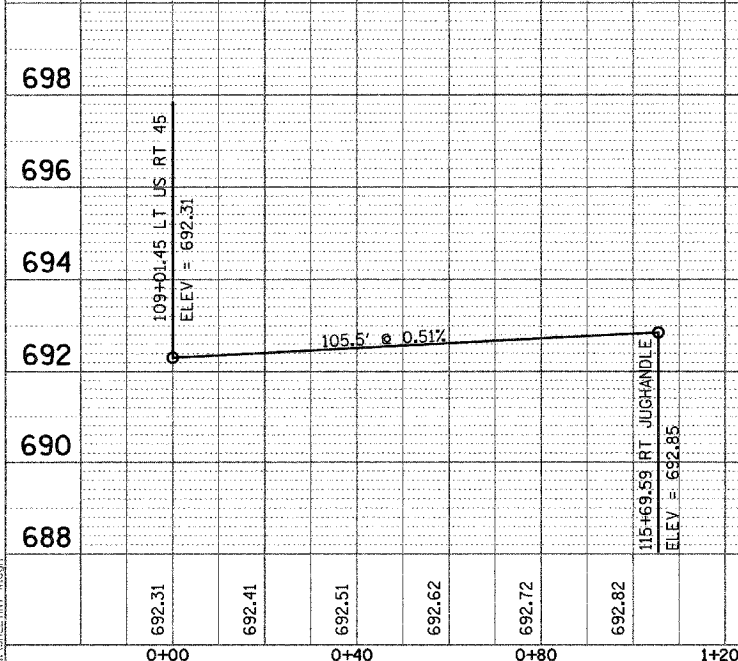

**NORTHWEST QUADRANT
OF INTERSECTION
US RT 45 & JUGHANDLE**

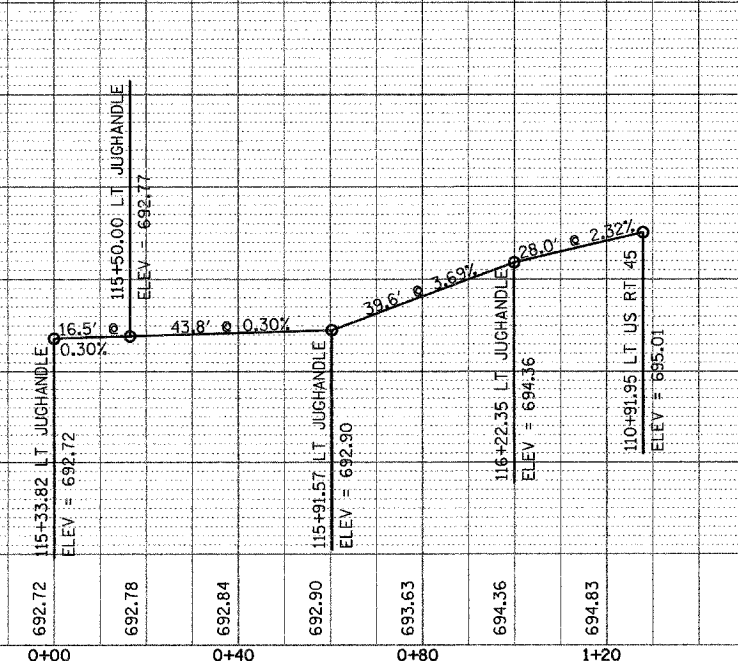

REVISIONS	
NAME	DATE

ILLINOIS DEPARTMENT OF TRANSPORTATION
**INTERSECTION GUTTER
PROFILES**

SCALE: VERT. 1"=2'
HORIZ. 1"=20'
DATE 04/01/2005

DRAWN BY RLH
CHECKED BY MED

SURVEYED PLOTTED CHECKED
 NOTE BOOK NO. _____
 CAD FILE NAME _____
 STRUCTURE NOTATION CHRD

F.A.S. RTE.	SECTION	COUNTY	TOTAL SHEETS	SHEET NO.
642	99-00124-01-PV	COLES	157	49
STA.		TO STA.		
FED. ROAD DIST. NO.		ILLINOIS FED. AID PROJECT		

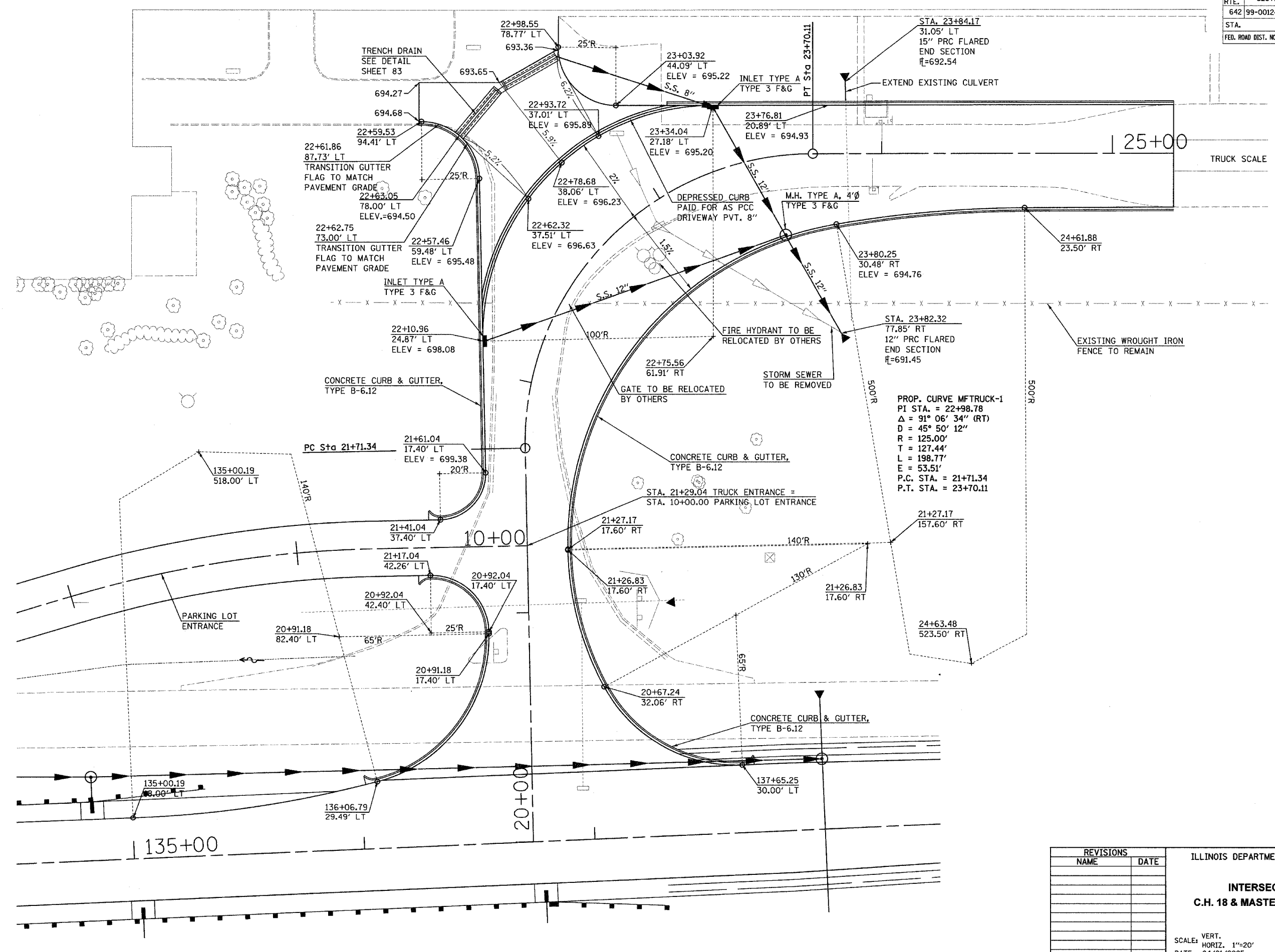

REVISIONS	
NAME	DATE

ILLINOIS DEPARTMENT OF TRANSPORTATION
INTERSECTION DETAIL
C.H. 18 & MASTERFOODS ENTRANCE

SCALE: VERT. 1"=20'
 HORIZ. 1"=20'
 DATE 04/01/2005

DRAWN BY RLH
 CHECKED BY MED

TUC PROJ #01022-5
 \N\SHEET\W.dgn
 04/01/2005

F.A.S. RTE.	SECTION	COUNTY	TOTAL SHEETS	SHEET NO.
642	99-00124-01-PV	COLES	157	50
STA.		TO STA.		
FED. ROAD DIST. NO.	ILLINOIS	FED. AID PROJECT		

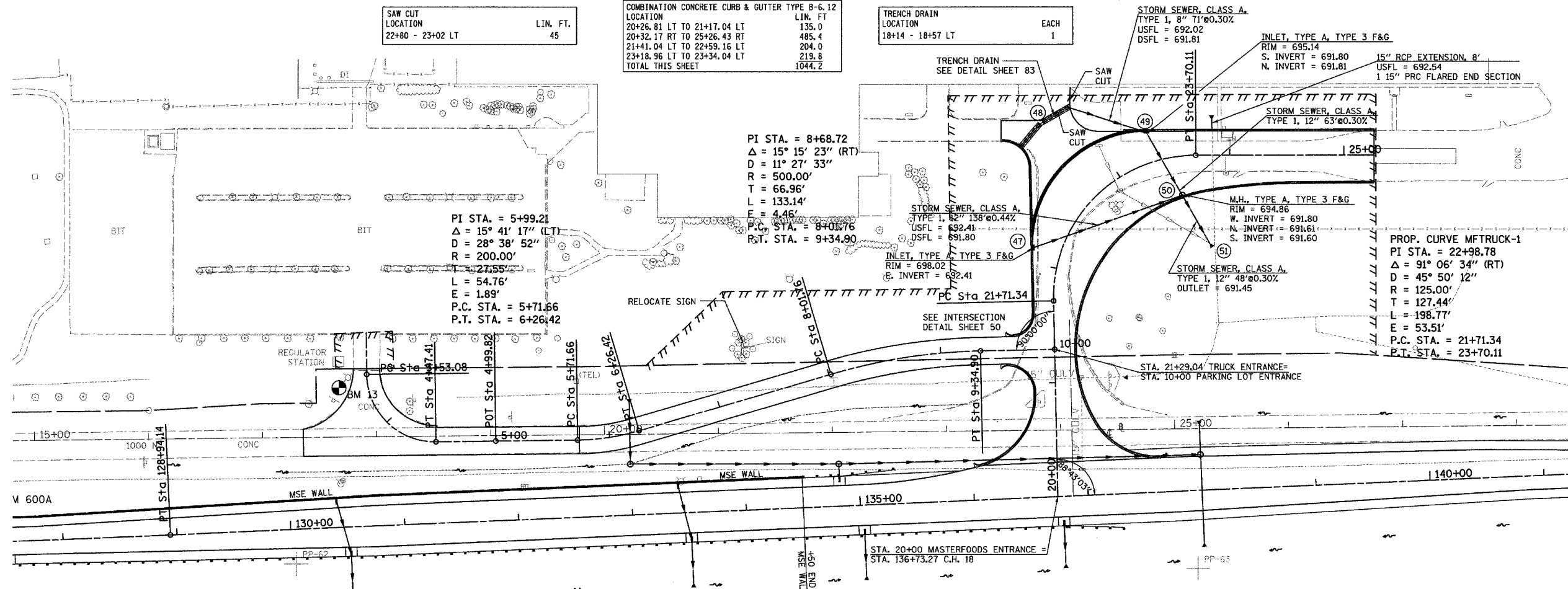

SAW CUT LOCATION	LIN. FT.
22+80 - 23+02 LT	45

COMBINATION CONCRETE CURB & GUTTER TYPE B-G. 12 LOCATION	LIN. FT.
20+26.81 LT TO 21+17.04 LT	135.0
20+32.17 RT TO 25+26.43 RT	485.4
21+41.04 LT TO 22+59.16 LT	204.0
23+18.96 LT TO 23+34.04 LT	219.8
TOTAL THIS SHEET	1044.2

TRENCH DRAIN LOCATION	EACH
18+14 - 18+57 LT	1

STORM SEWER, CLASS A.
TYPE 1, 8" 71'@0.30%
USFL = 692.02
DSFL = 691.81

INLET, TYPE A, TYPE 3 F&G
RIM = 695.14
S. INVERT = 691.80
N. INVERT = 691.81

15" RCP EXTENSION, 8'
USFL = 692.54
1 15" PRC FLARED END SECTION

STORM SEWER, CLASS A.
TYPE 1, 12" 63'@0.30%

M.H., TYPE A, TYPE 3 F&G
RIM = 694.86
W. INVERT = 691.80
N. INVERT = 691.61
S. INVERT = 691.60

STORM SEWER, CLASS A.
TYPE 1, 12" 48'@0.30%
OUTLET = 691.45

PROP. CURVE MFTRUCK-1
PI STA. = 22+98.78
Δ = 91° 06' 34" (RT)
D = 45° 50' 12"
R = 125.00'
T = 127.44'
L = 198.77'
E = 53.51'
P.C. STA. = 21+71.34
P.T. STA. = 23+70.11

PI STA. = 8+68.72
Δ = 15° 15' 23" (RT)
D = 11° 27' 33"
R = 500.00'
T = 66.96'
L = 133.14'
E = 4.46'
P.C. STA. = 8+01.76
P.T. STA. = 9+34.90

PI STA. = 5+99.21
Δ = 15° 41' 17" (LT)
D = 28° 38' 52"
R = 200.00'
T = 27.55'
L = 54.76'
E = 1.89'
P.C. STA. = 5+71.66
P.T. STA. = 6+26.42

PCC DRIVEWAY PAVEMENT, 8" LOCATION	SQ. YD.
136+08.22 LT	4509.4

BITUMINOUS PRIME COAT LOCATION	GALLONS
130+13.60, LT TO 132+60.06, LT	84.1

INCIDENTAL BITUMINOUS SURFACING LOCATION	TONS
130+13.60, LT TO 132+60.06, LT	70.6

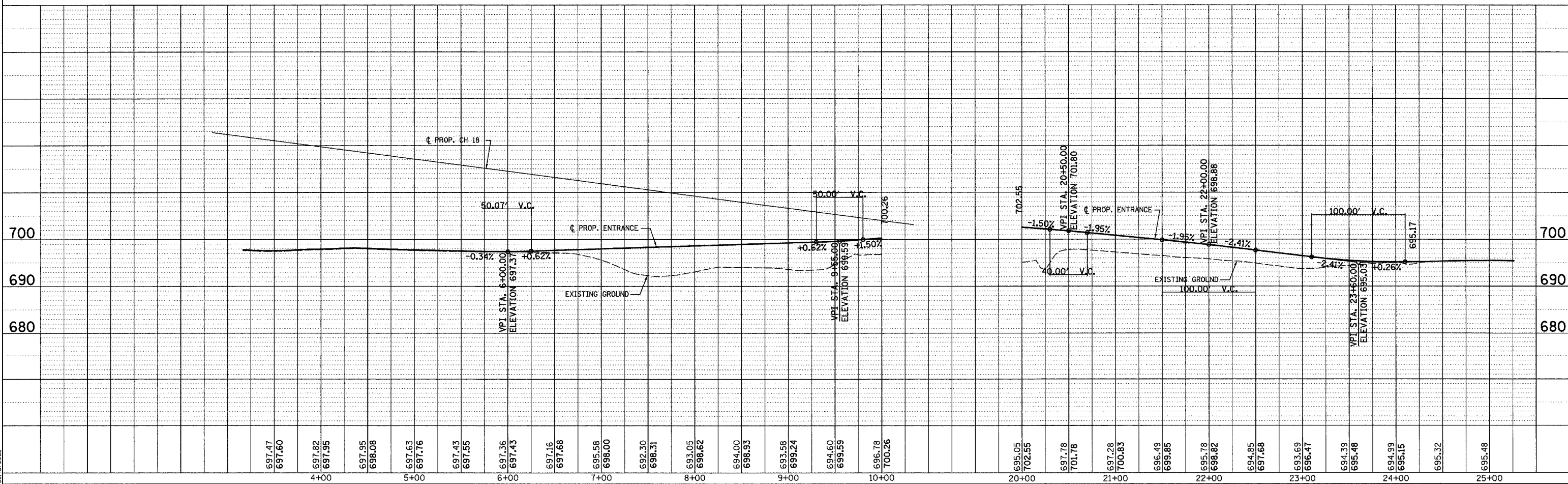

DRAWN BY: RLH
 CHECKED BY: MED
 DATE: 08/16/2005
 PROJECT: Masterfoods Entrance - PLR.dgn

F.A.S. RTE.	SECTION	COUNTY	TOTAL SHEETS	SHEET NO.
642	99-00124-01-PV	COLES	157	51
STA. TO STA.		FED. ROAD DIST. NO. ILLINOIS FED. AID PROJECT		

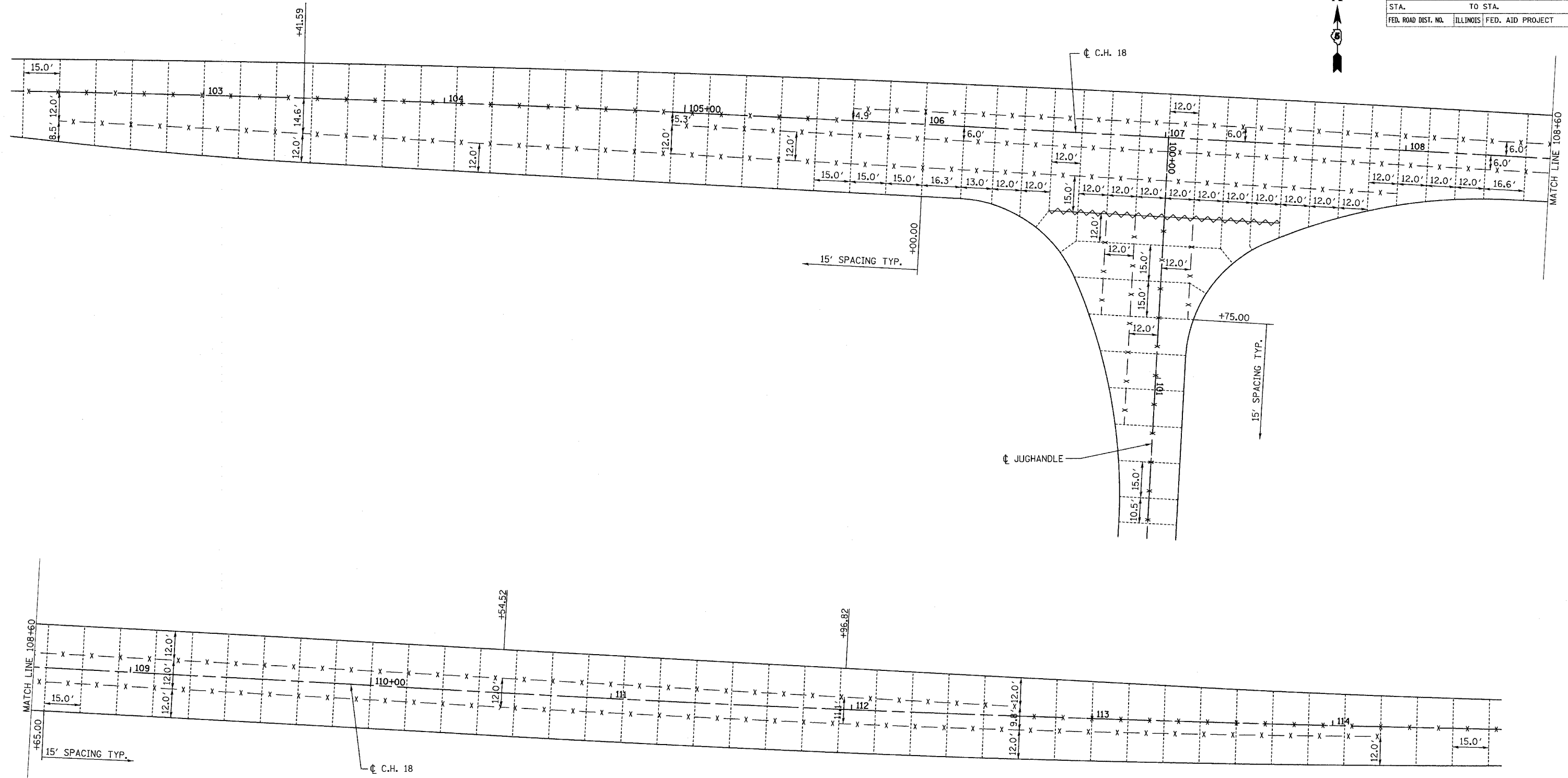

LEGEND

- KEYED CONSTRUCTION JOINT
- SAWED LONGITUDINAL JOINT OR LONGITUDINAL CONSTRUCTION JOINT
- TRANSVERSE SAWED CONTRACTION JOINT

REVISIONS	
NAME	DATE

ILLINOIS DEPARTMENT OF TRANSPORTATION

PAVEMENT JOINTING PLAN
C.H. 18 & JUGHANDLE

SCALE: VERT. HORIZ. 1"=20'
DATE 04/08/2005

DRAWN BY RLH
CHECKED BY MED

TUG PROJ. #397022-5
SHEET 108+60
04/08/2005

F.A.S. RTE.	SECTION	COUNTY	TOTAL SHEETS	SHEET NO.
642	99-00124-01-PV	COLES	157	52
STA.	TO STA.			
FED. ROAD DIST. NO.	ILLINOIS	FED. AID PROJECT		

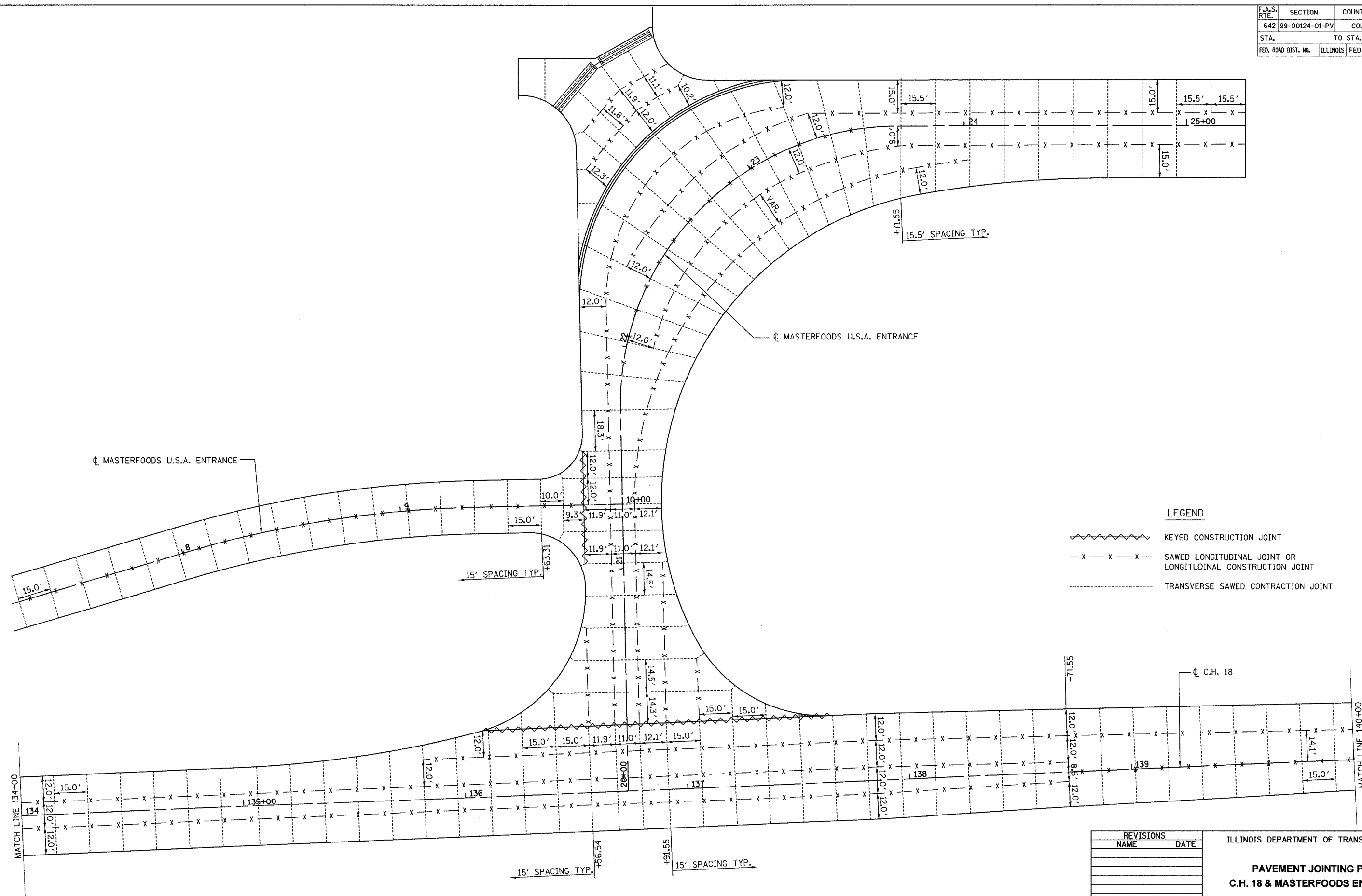

LEGEND

- KEYED CONSTRUCTION JOINT
- SAWED LONGITUDINAL JOINT OR LONGITUDINAL CONSTRUCTION JOINT
- TRANSVERSE SAWED CONTRACTION JOINT

REVISIONS	
NAME	DATE

ILLINOIS DEPARTMENT OF TRANSPORTATION
PAVEMENT JOINTING PLAN
C.H. 18 & MASTERFOODS ENTRANCE

SCALE: VERT. 1"=20'
 HORIZ. 1"=20'
 DATE 04/08/2005

DRAWN BY RLH
 CHECKED BY MED

TUG PROJ #9197022-5
 SHEET JOINT-W.DGN
 04/08/2005

F.A.S. RTE.	SECTION	COUNTY	TOTAL SHEETS	SHEET NO.
642	99-00124-01-PV	COLES	157	53
STA.		TO STA.		
FED. ROAD DIST. NO.		ILLINOIS	FED. AID PROJECT	

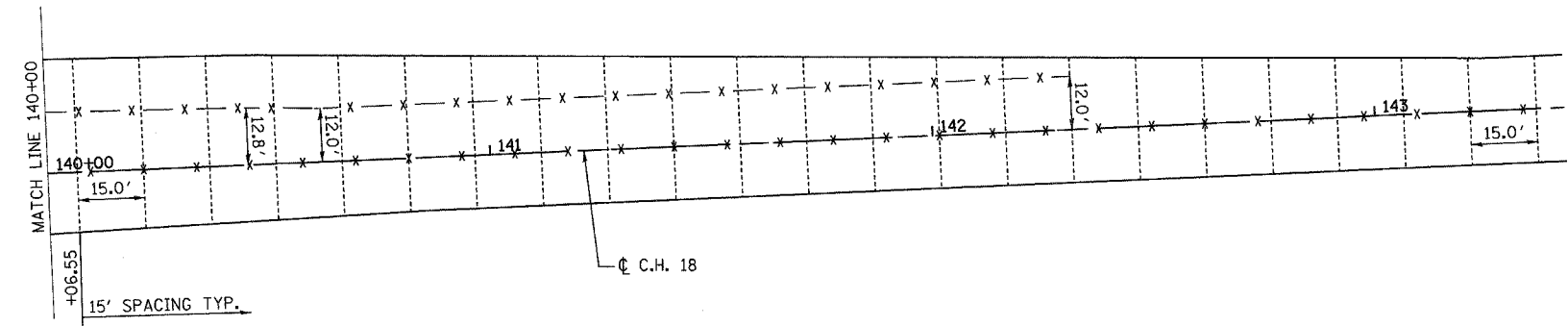
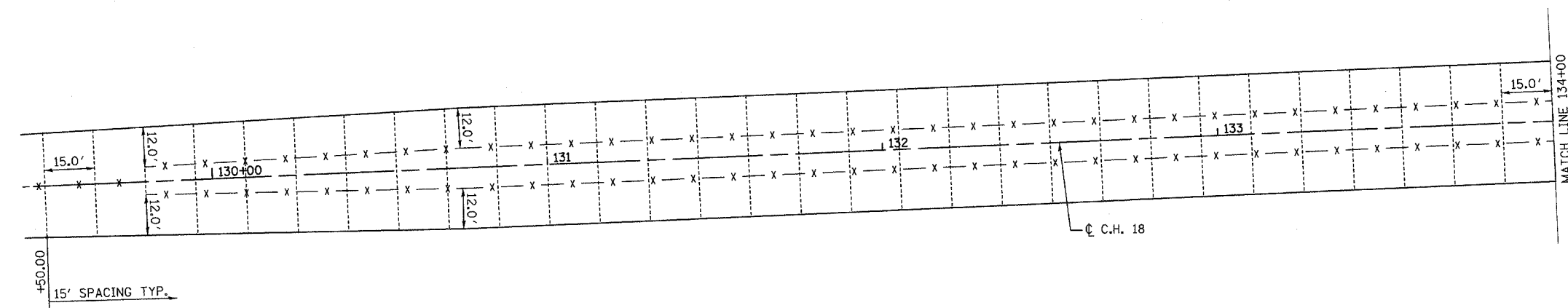

LEGEND

- KEYED CONSTRUCTION JOINT
- SAWED LONGITUDINAL JOINT OR LONGITUDINAL CONSTRUCTION JOINT
- TRANSVERSE SAWED CONTRACTION JOINT

REVISIONS	
NAME	DATE

ILLINOIS DEPARTMENT OF TRANSPORTATION
PAVEMENT JOINTING PLAN
C.H. 18 & MASTERFOODS ENTRANCE

SCALE: VERT. 1"=20'
HORIZ. 1"=20'
DATE 04/08/2005

DRAWN BY RLH
CHECKED BY MED

TUG PROJ # 91292-5
 SHEET JOINT-18.DGN
 04/08/2005

F.A.S. RTE.	SECTION	COUNTY	TOTAL SHEETS	SHEET NO.
642	99-00124-01-PV	COLES	157	54
STA.	TO STA.			
FED. ROAD DIST. NO.	ILLINOIS	FED. AID PROJECT		

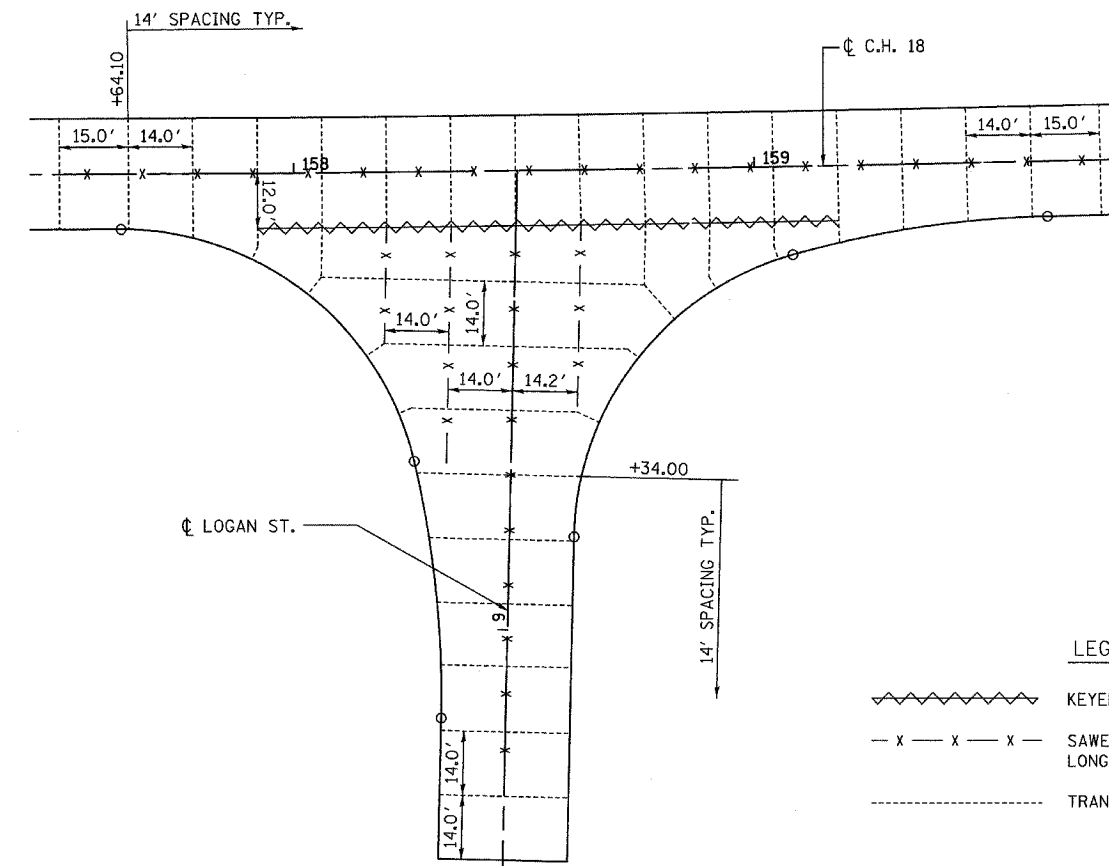
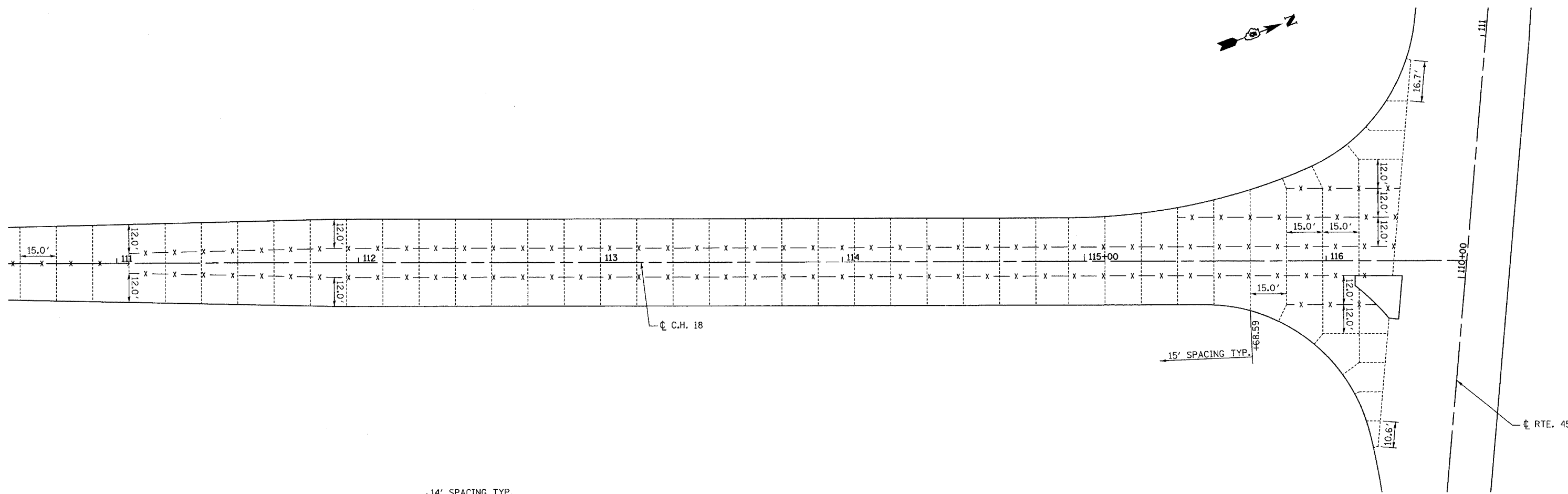

LEGEND

KEYED CONSTRUCTION JOINT
 SAWED LONGITUDINAL JOINT OR LONGITUDINAL CONSTRUCTION JOINT
 TRANSVERSE SAWED CONTRACTION JOINT

REVISIONS	
NAME	DATE

ILLINOIS DEPARTMENT OF TRANSPORTATION

**PAVEMENT JOINTING PLAN
U.S. RTE. 45 & JUGHANDLE
C.H. 18 & LOGAN ST.**

SCALE: VERT. 1"=20'
 DATE: 04/08/2005

DRAWN BY: RLH
 CHECKED BY: MED

F.A.S. RTE.	SECTION	COUNTY	TOTAL SHEETS	SHEET NO.
642	99-00124-01-PV	COLES	157	55
STA.	TO STA.			
FED. ROAD DIST. NO.	ILLINOIS	FED. AID PROJECT		

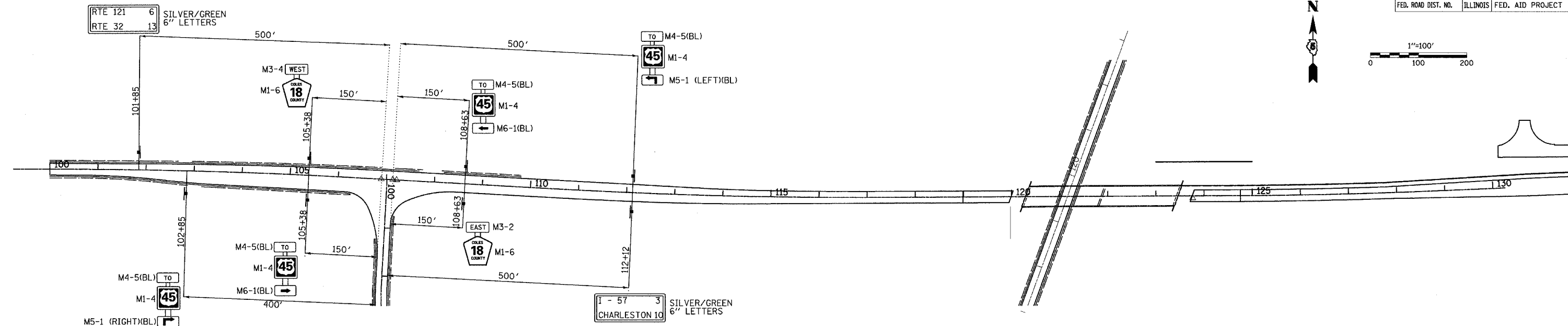
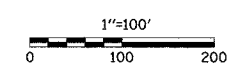

C.H. 18

STATION	SIDE	SIGN TYPE	DESCRIPTION	SIGN PANEL TYPE 1 SQ FT	SIGN PANEL TYPE 2 SQ FT	NUMBER OF POSTS EACH	TELESCOPING STEEL SIGN SUPPORT FOOT
COUNTY HIGHWAY 18							
101+85	LT	D2-2	DISTANCE SIGN		11.0	2	33
102+85	RT	M4-5(BL)	TO	2.0		1	19
		M1-4	US 45	4.0			
		M5-1(RIGHT)(BL)	ADVANCE TURN ARROW	2.2			
105+38	LT	M3-4	WEST	2.0		1	17
		M1-6	COUNTY HIGHWAY 18	4.0			
		M4-5(BL)	TO	2.0			
105+38	RT	M1-4	US 45	4.0		1	19
		M6-1(BL)	DIRECTIONAL	2.2			
		M4-5(BL)	TO	2.0			
108+63	LT	M1-4	US 45	4.0		1	19
		M6-1(BL)	DIRECTIONAL	2.2			
		M3-2	EAST	2.0			
108+63	RT	M1-6	COUNTY HIGHWAY 18	4.0		1	17
		M1-4	US 45	4.0			
		M4-5(BL)	TO	2.0			
112+12	LT	M1-4	US 45	4.0		1	19
		M5-1(LEFT)(BL)	ADVANCE TURN ARROW	2.2			
		M4-5(BL)	TO	2.0			
112+12	RT	D2-2	DISTANCE SIGN		14.9	2	33
US 45							
104+89	LT	D2-1	DISTANCE SIGN	7.4		2	30
104+89	RT	M4-5(BL)	TO	2.0		1	19
		M1-1	I-57	4.0			
		M5-1(LEFT)(BL)	ADVANCE TURN ARROW	2.2			
108+39	LT	M3-3	SOUTH	2.0		1	17
		M1-4	US 45	4.0			
		M4-5(BL)	TO	2.0			
108+39	RT	M1-1	I-57	4.0		1	17
		M6-1(BL)	DIRECTIONAL	2.2			
		M4-5(BL)	TO	2.0			
111+75	LT	M1-1	I-57	4.0		1	19
		M6-1(BL)	DIRECTIONAL	2.2			
		M3-1	NORTH	2.0			
111+75	RT	M1-4	US 45	4.0		1	17
		M4-5(BL)	TO	2.0			
		M5-1(RIGHT)(BL)	ADVANCE TURN ARROW	2.2			
115+25	LT	M1-1	I-57	4.0		1	19
		M4-5(BL)	TO	2.0			
		M5-1(LEFT)(BL)	ADVANCE TURN ARROW	2.2			
115+25	RT	D2-2	DISTANCE SIGN		12.5	2	33
TOTALS				97.0	38.4	20	347

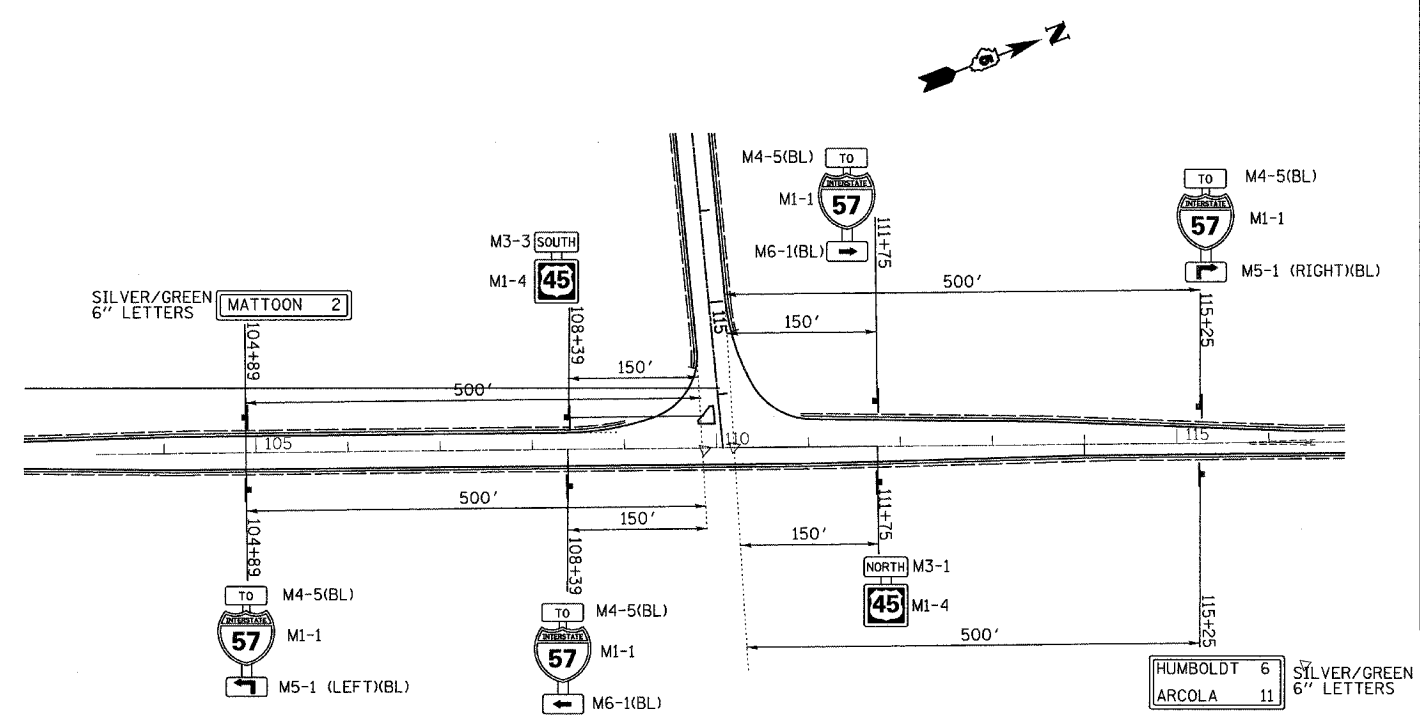

US RTE. 45

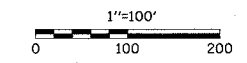

REVISIONS	
NAME	DATE

ILLINOIS DEPARTMENT OF TRANSPORTATION

SIGNING PLAN

SCALE: VERT. HORIZ. 1" = 100'
DATE 04/01/2005

DRAWN BY RLH
CHECKED BY MED

TUG PROJ #1917022-5
 SHEET(S) 491
 04/01/2005

F.A.S. RTE.	SECTION	COUNTY	TOTAL SHEETS	SHEET NO.
642	99-00124-01-PV	COLES	157	56
STA.		TO STA.		
FED. ROAD DIST. NO.		ILLINOIS	FED. AID PROJECT	

STATION	SIDE	SIGN TYPE	DESCRIPTION	SIGN PANEL	SIGN PANEL	NUMBER OF POSTS EACH	TELESCOPING STEEL SIGN SUPPORT FOOT
				TYPE 1 SQ FT	TYPE 2 SQ FT		
100+48	LT	R1-1	STOP	6.3		1	16
100+48	LT	M4-5(BL)	TO	2.0		1	20
		M1-1	I-57	4.0			
		M6-1(BL)	DIRECTIONAL	2.2			
102+18	LT	D1-2	DIRECTIONAL		15.5	2	33
104+18	LT	M2-1	JUNCTION	2.0		1	17
		M1-6	COUNTY HIGHWAY 18	4.0			
110+75	RT	W3-1a	STOP AHEAD	6.3		1	16
112+25	RT	M2-1	JUNCTION	2.0		1	17
		M1-4	US 45	4.0			
114+25	RT	D1-2	DIRECTIONAL		12.7	2	33
115+95	RT	R1-1	STOP	6.3		1	16
115+95	RT	M1-4	US 45	4.0		1	18
		M6-4	DIRECTIONAL	2.2			
116+25	RT	R1-1	STOP	6.3		1	17
TOTALS				51.6	28.2	12	203

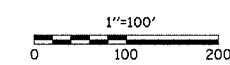
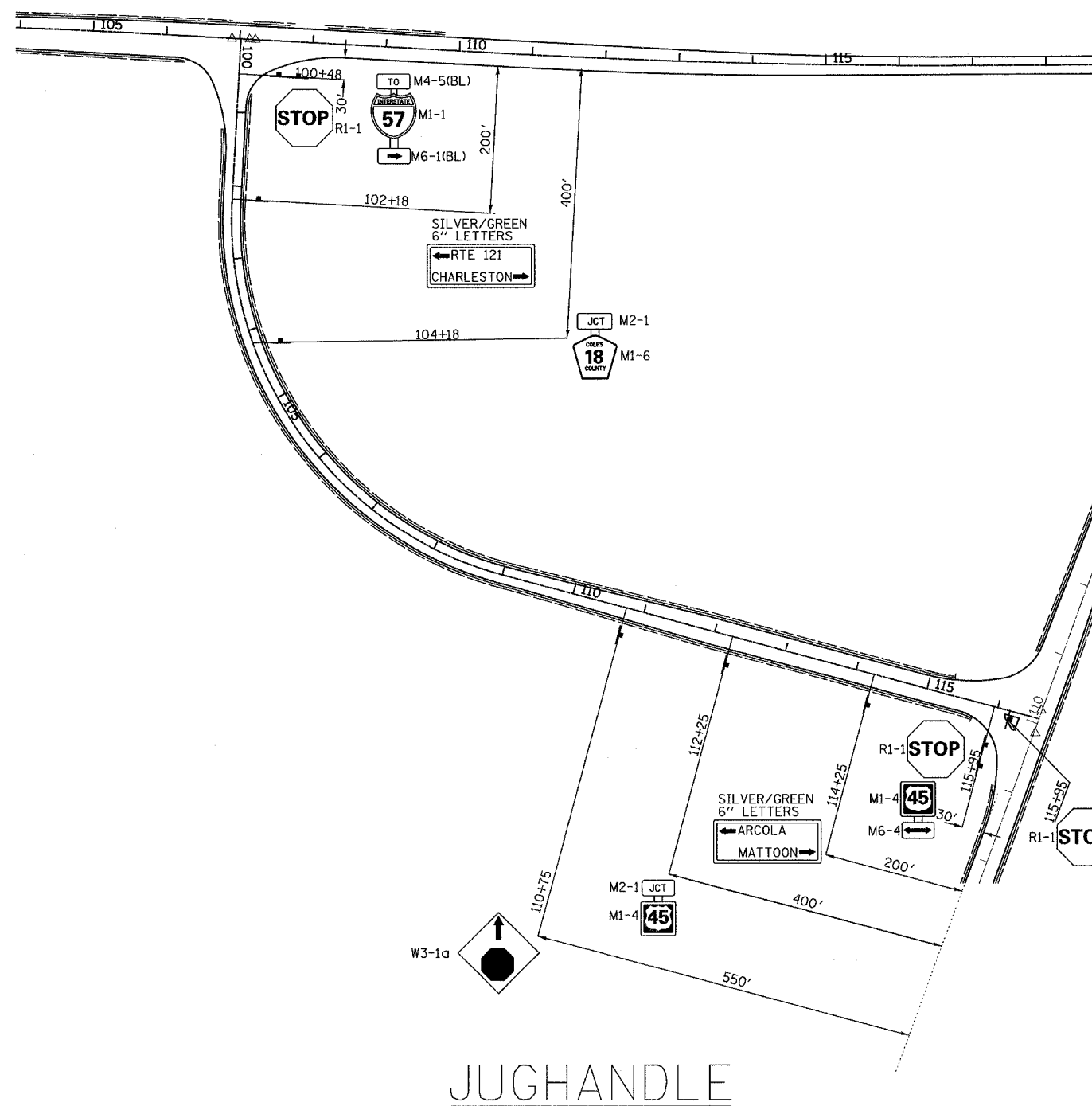

REVISIONS	
NAME	DATE

ILLINOIS DEPARTMENT OF TRANSPORTATION

SIGNING PLAN

SCALE: VERT. 1" = 100'
 HORIZ. 1" = 100'
 DATE 04/01/2005

DRAWN BY RLH
 CHECKED BY MED

TUG PROJ #197022-5
 \SHEETS\DWG.dgn
 04/01/2005

F.A.S. RTE.	SECTION	COUNTY	TOTAL SHEETS	SHEET NO.
642	99-00124-01-PV	COLES	157	57
STA.	TO STA.			
FED. ROAD DIST. NO.	ILLINOIS	FED. AID PROJECT		

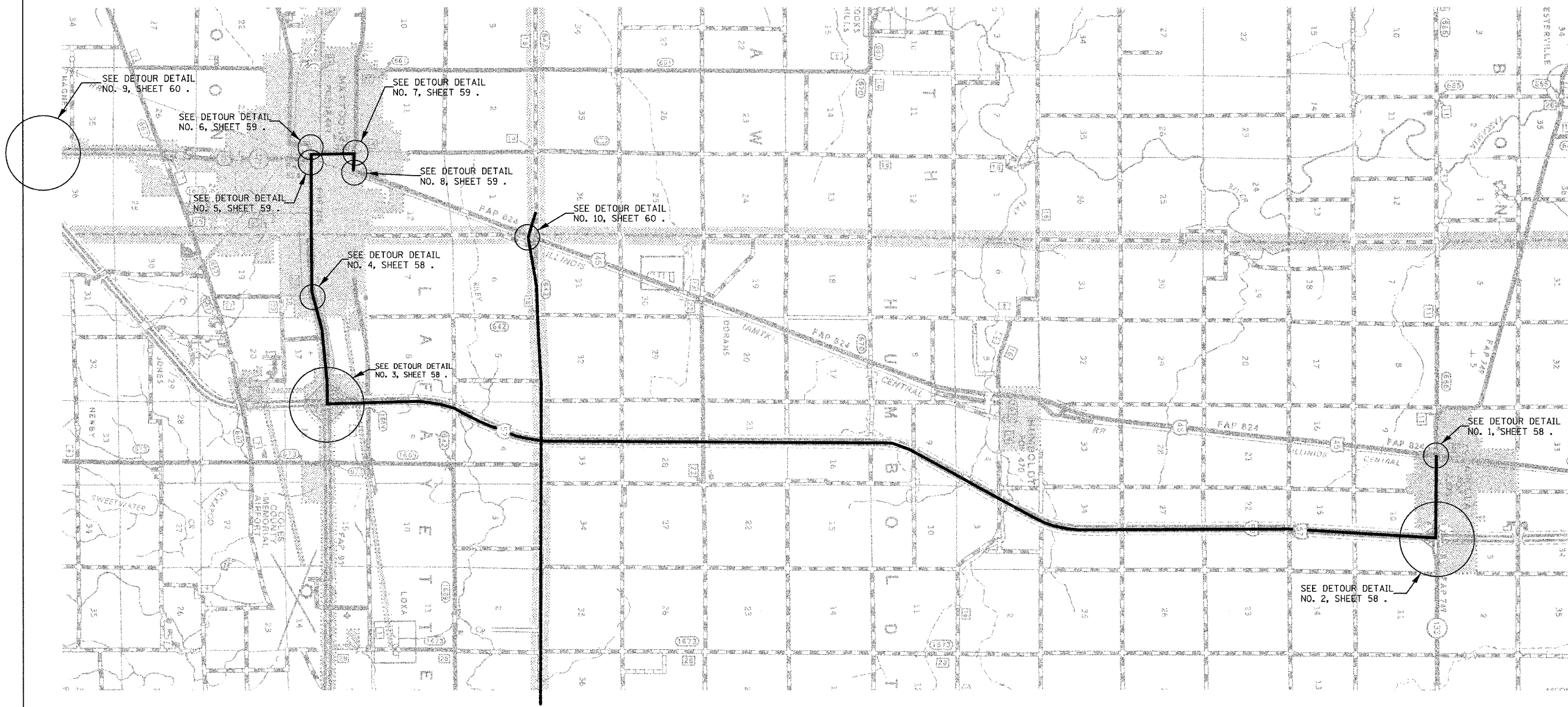

NOTE:
 PORTABLE CHANGEABLE MESSAGE SIGNS TO BE PROVIDED AND PLACED BY CONTRACTOR, 7 EACH.
 TEMPORARY DETOUR SIGNS TO BE PROVIDED BY IDOT DISTRICT 7 AND ERECTED BY CONTRACTOR,
 SEE SPECIAL PROVISIONS.

REVISIONS	
NAME	DATE

ILLINOIS DEPARTMENT OF TRANSPORTATION

DETOUR PLAN

SCALE: VERT. N.T.S.
 HORIZ. N.T.S.
 DATE 09/02/2005

DRAWN BY RLH
 CHECKED BY MED

TUC PROJ. #1517022-5
 DETOUR PLAN
 09/02/2005

F.A.S. RTE.	SECTION	COUNTY	TOTAL SHEETS	SHEET NO.
642	99-00124-01-PV	COLES	157	58
STA. TO STA.		ILLINOIS FED. AID PROJECT		

DETOUR DETAIL 1

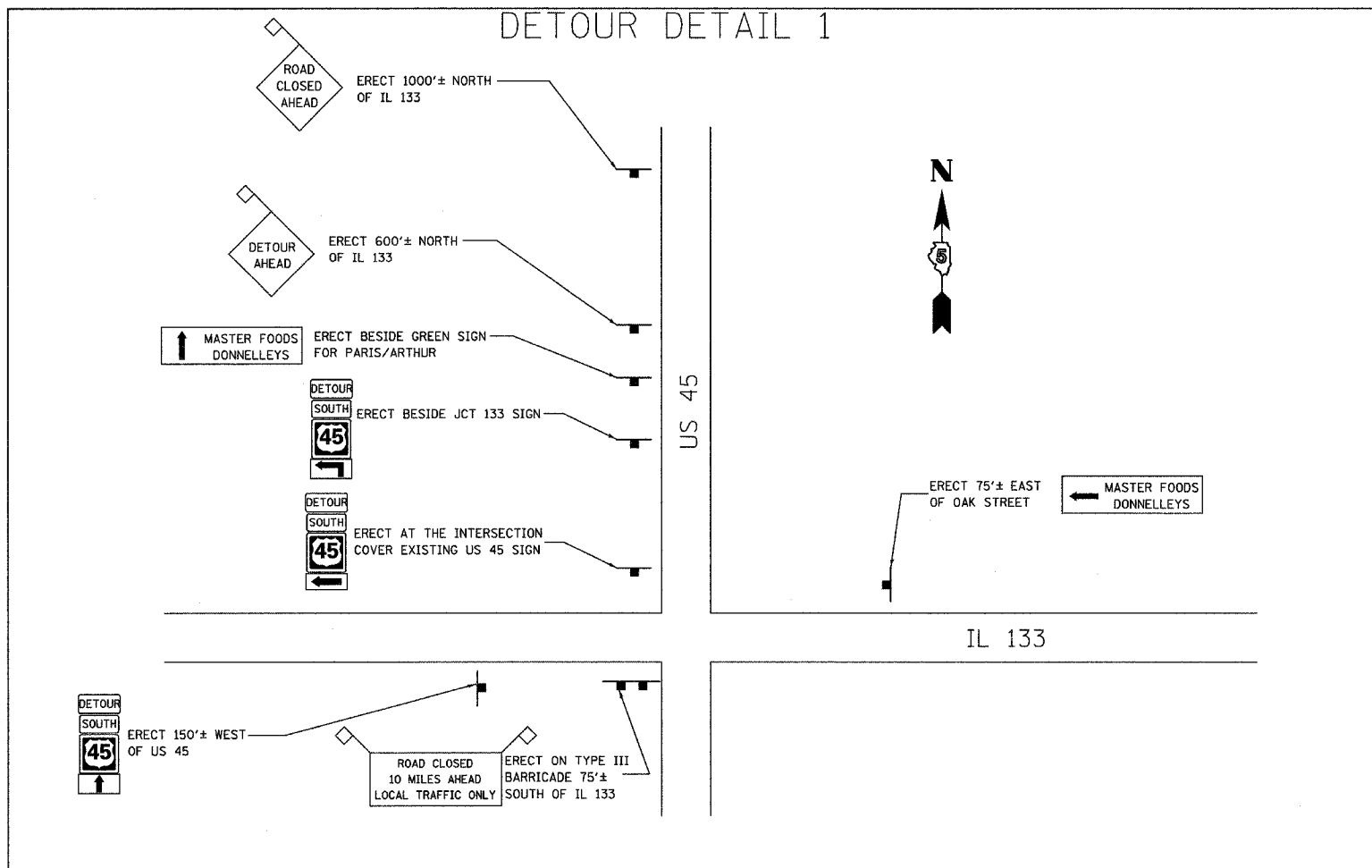

DETOUR DETAIL 2

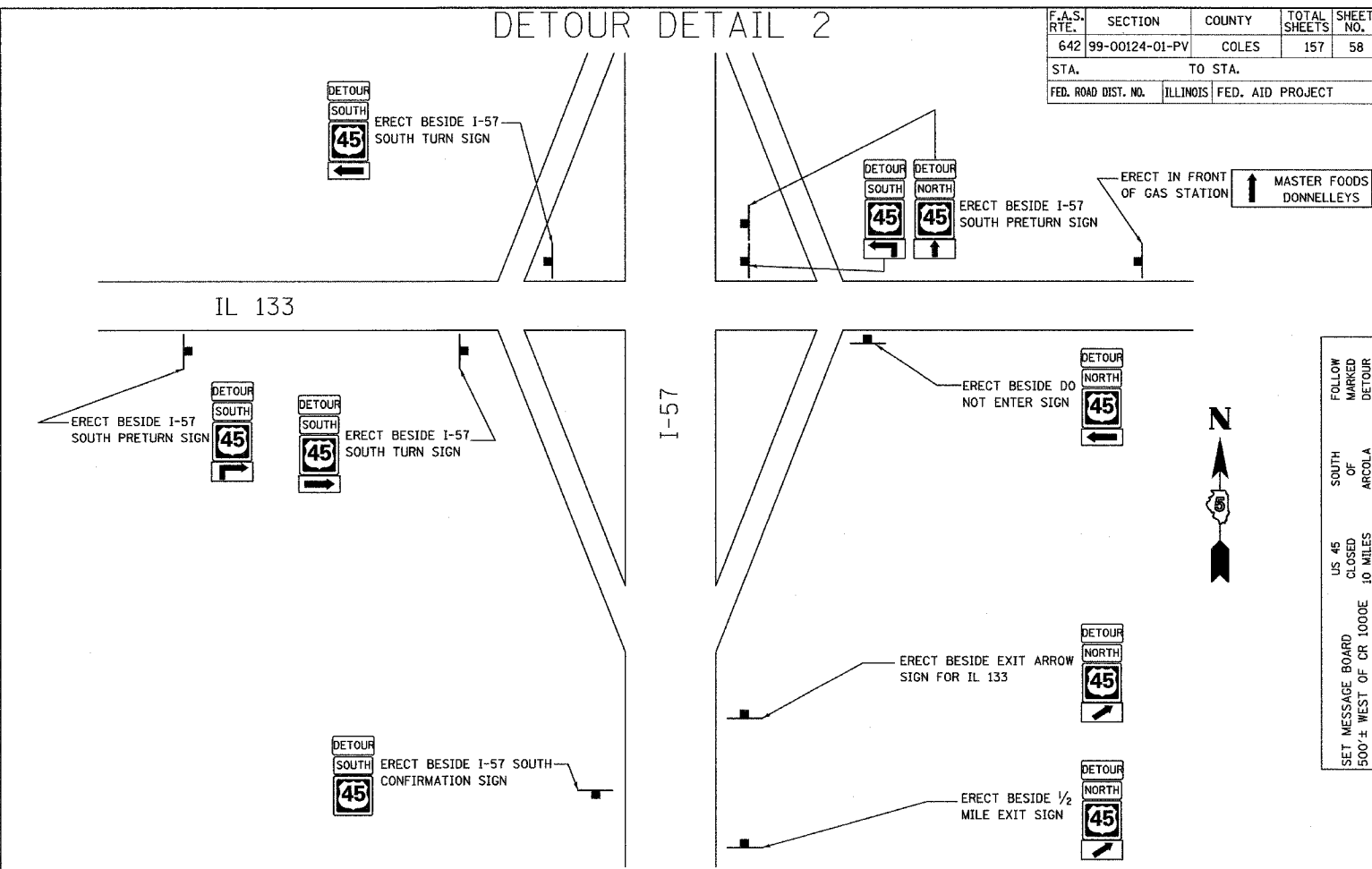

DETOUR DETAIL 3

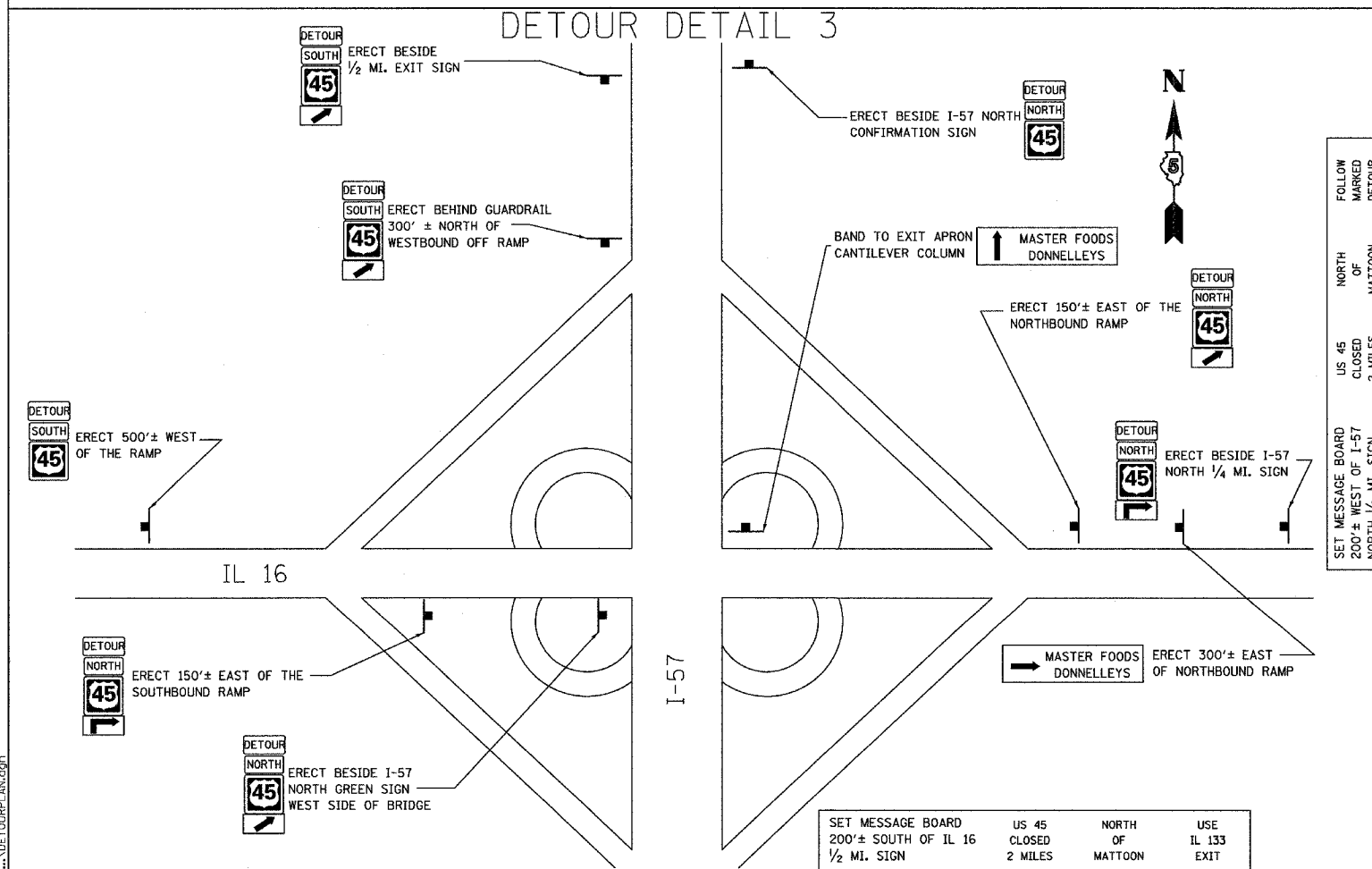

DETOUR DETAIL 4

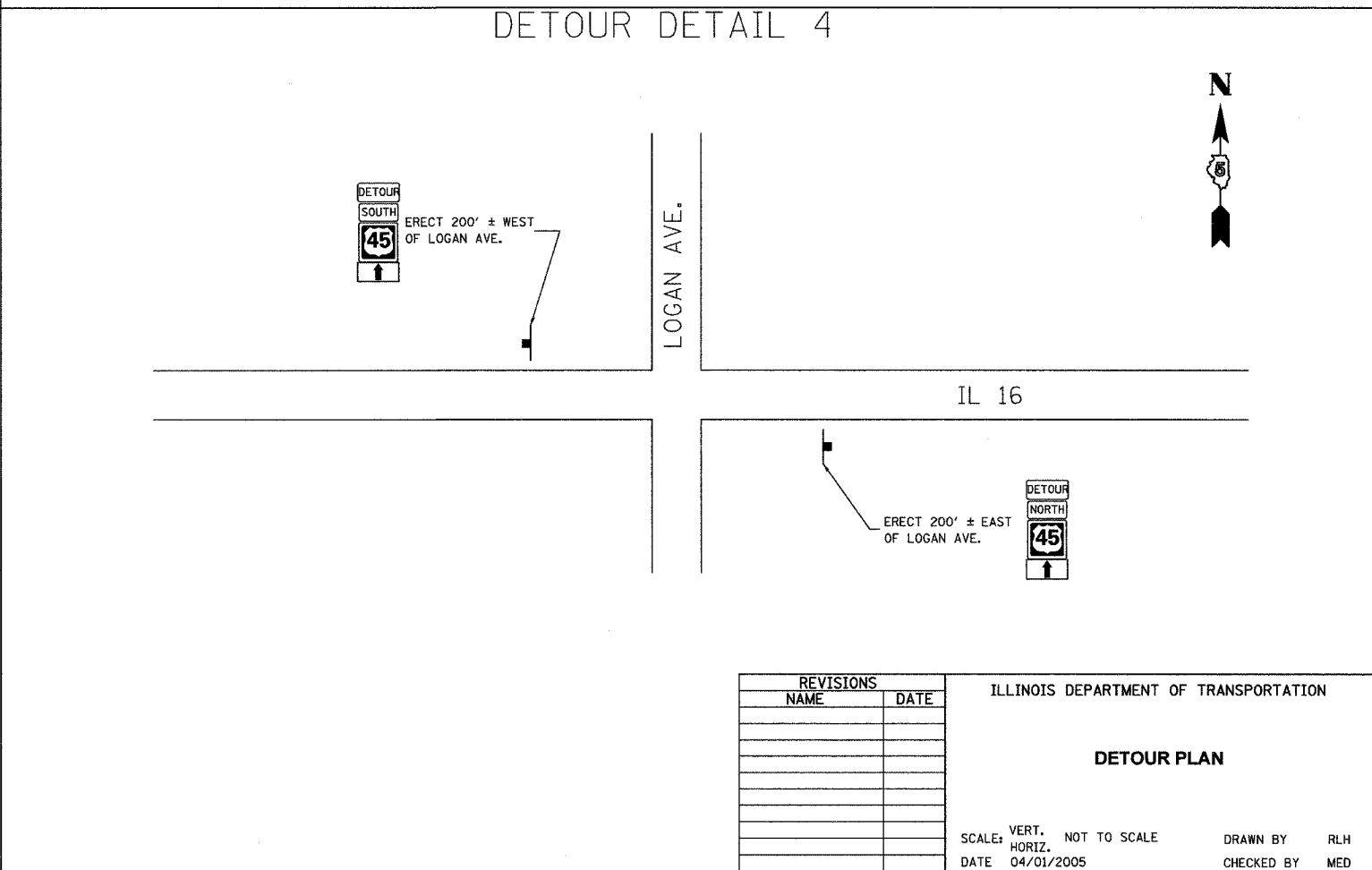

REVISIONS		ILLINOIS DEPARTMENT OF TRANSPORTATION
NAME	DATE	
		DETOUR PLAN

SCALE: VERT. NOT TO SCALE
 DATE 04/01/2005
 DRAWN BY R.L.H.
 CHECKED BY MED

TUG PROJ. #1917022-5
 DETOUR PLAN

F.A.S. RTE.	SECTION	COUNTY	TOTAL SHEETS	SHEET NO.
642	99-00124-01-PV	COLES	157	59
STA. TO STA.				
FED. ROAD DIST. NO.		ILLINOIS	FED. AID PROJECT	

DETOUR DETAIL 5

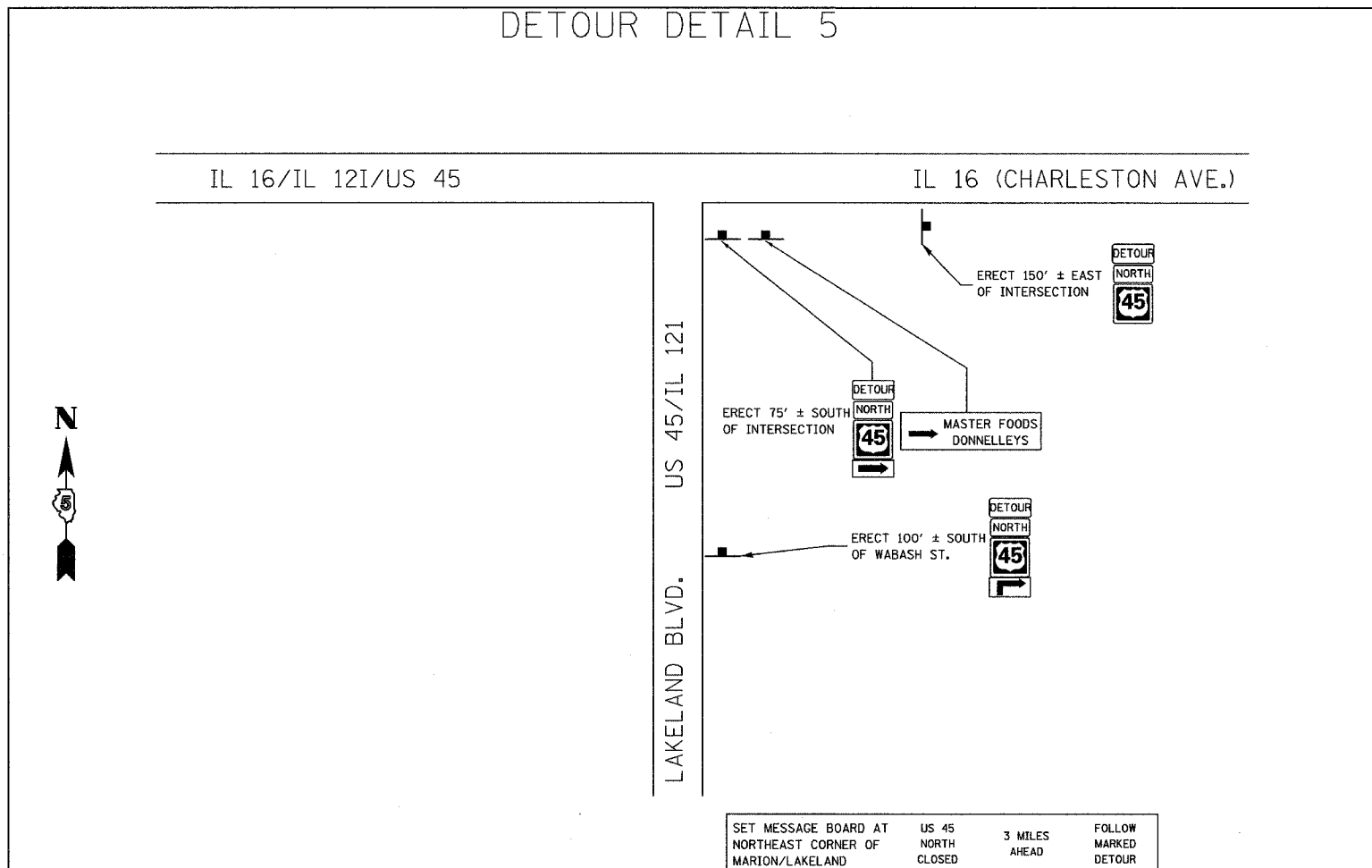

DETOUR DETAIL 6

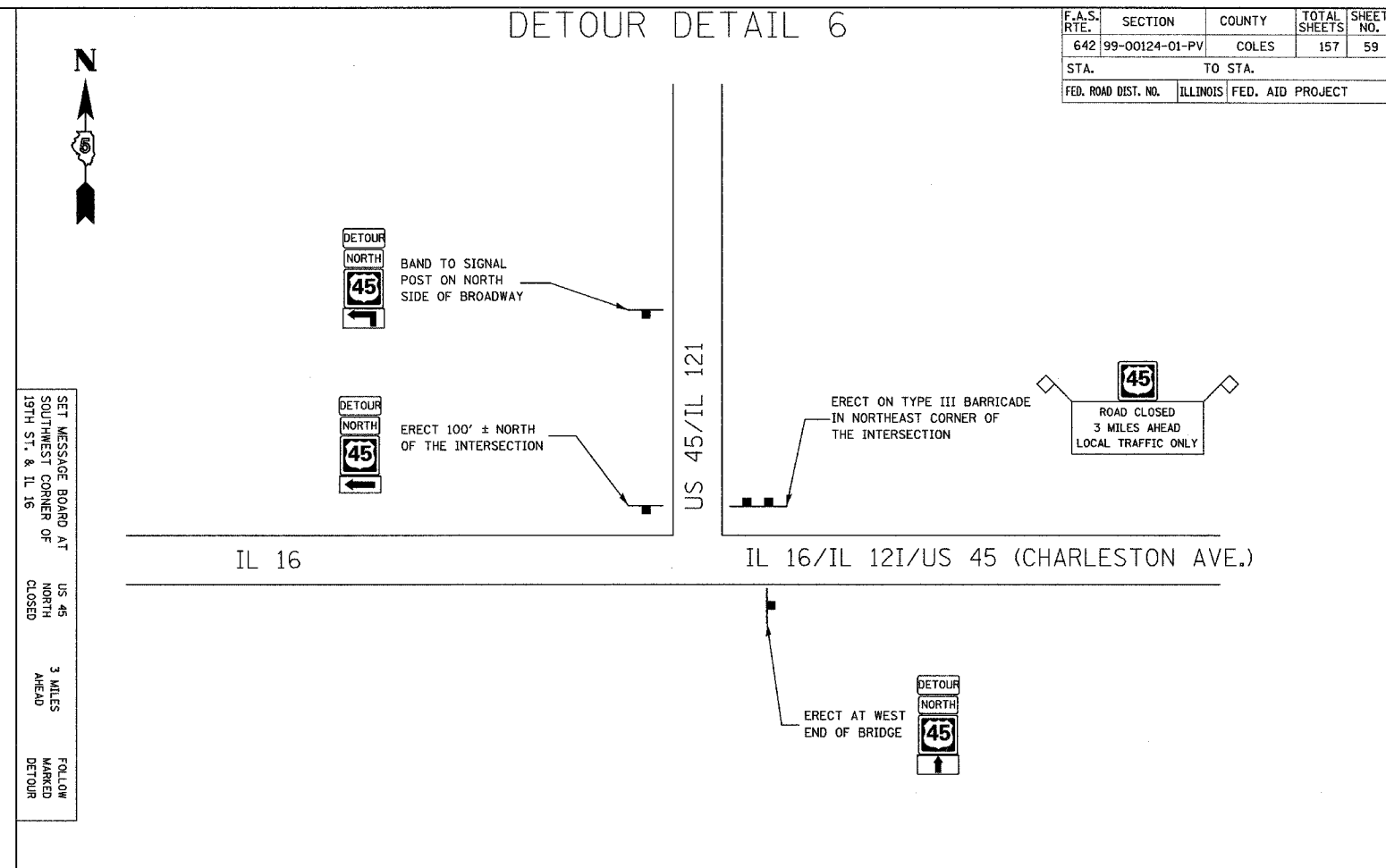

DETOUR DETAIL 7

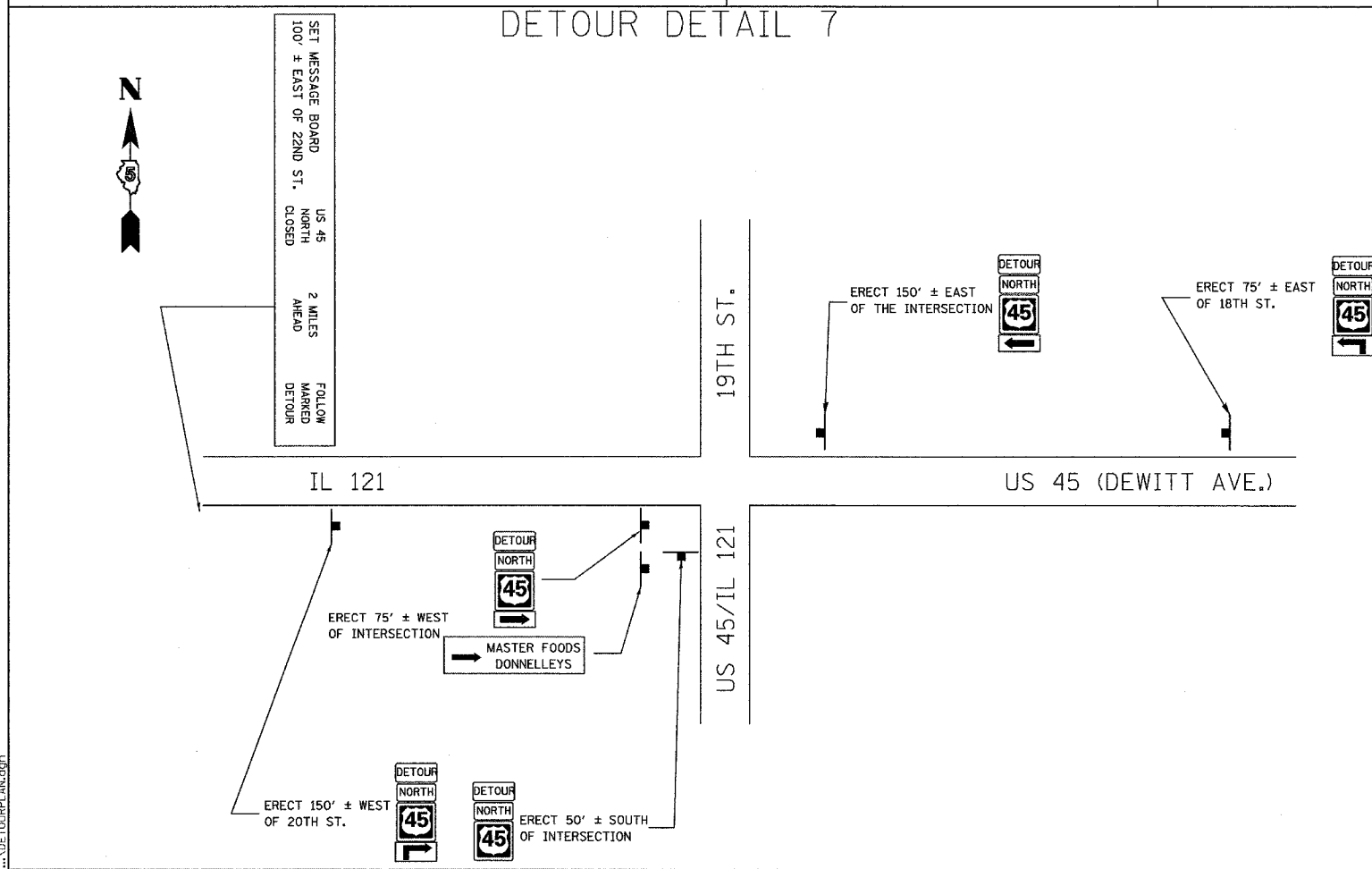

DETOUR DETAIL 8

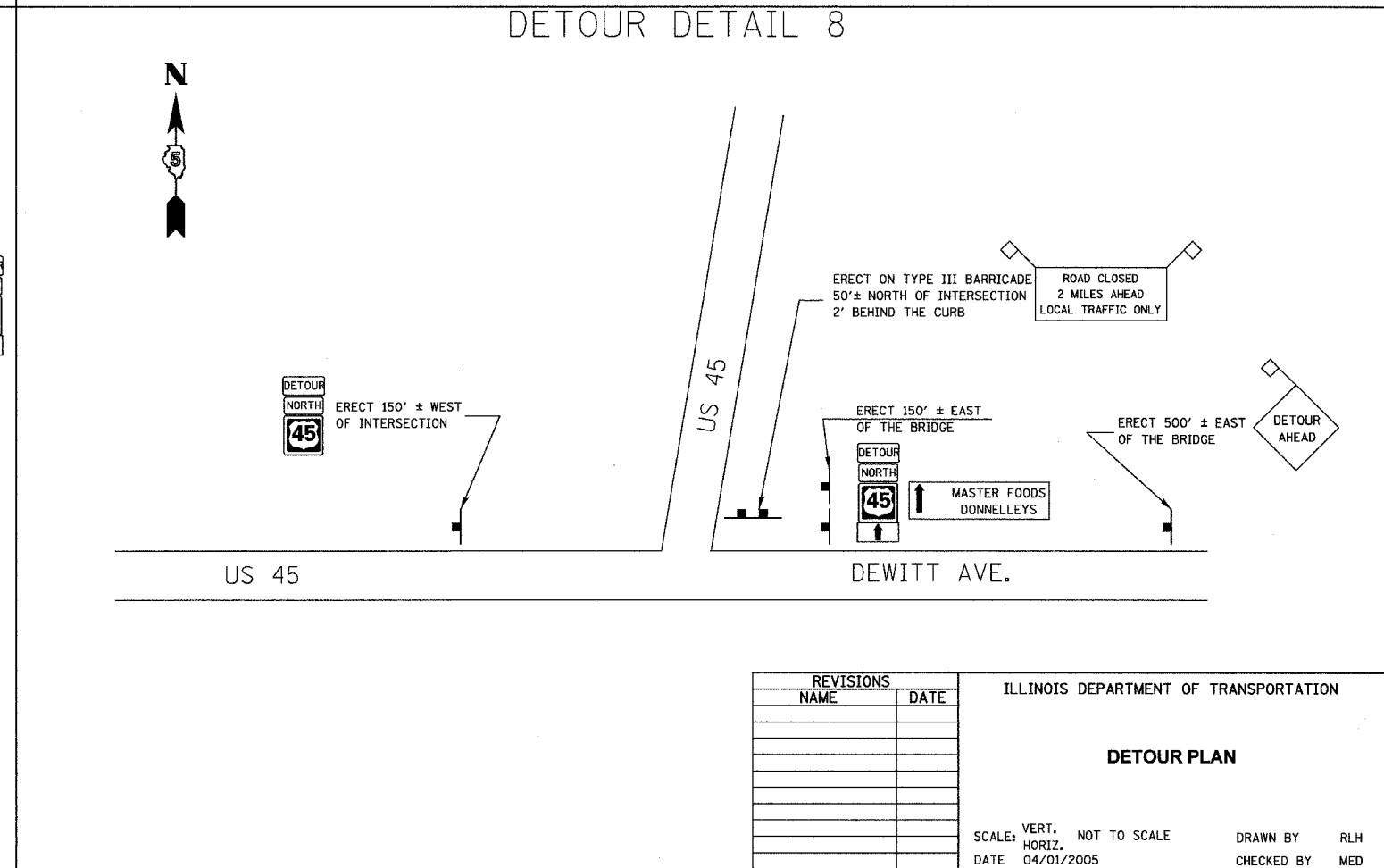

TUG PROJ. #191022-5
DETOUR PLAN.DGN

F.A.S. RTE.	SECTION	COUNTY	TOTAL SHEETS	SHEET NO.
642	99-00124-01-PV	COLES	157	60
STA.		TO STA.		
FED. ROAD DIST. NO.	ILLINOIS	FED. AID PROJECT		

DETOUR DETAIL 9

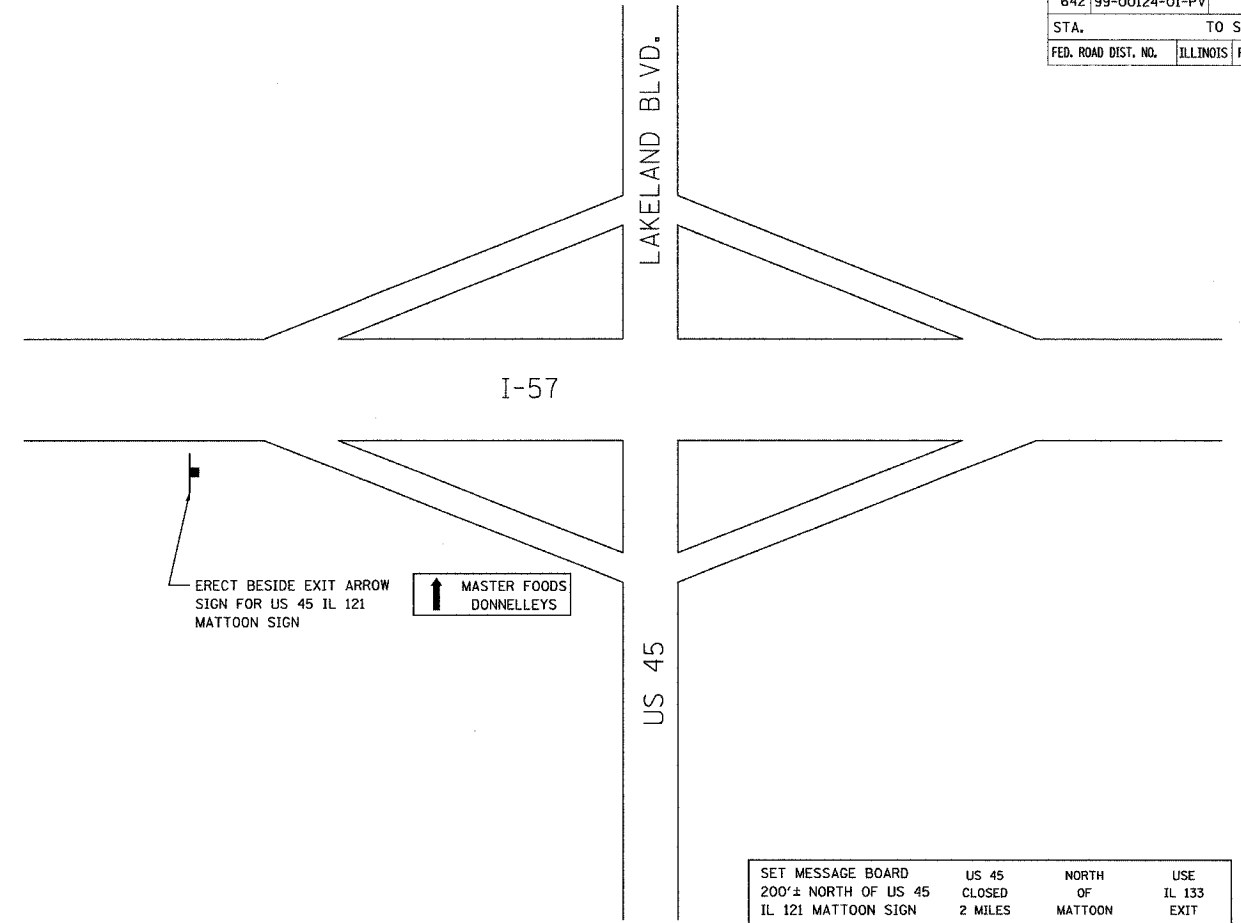

DETOUR DETAIL 10

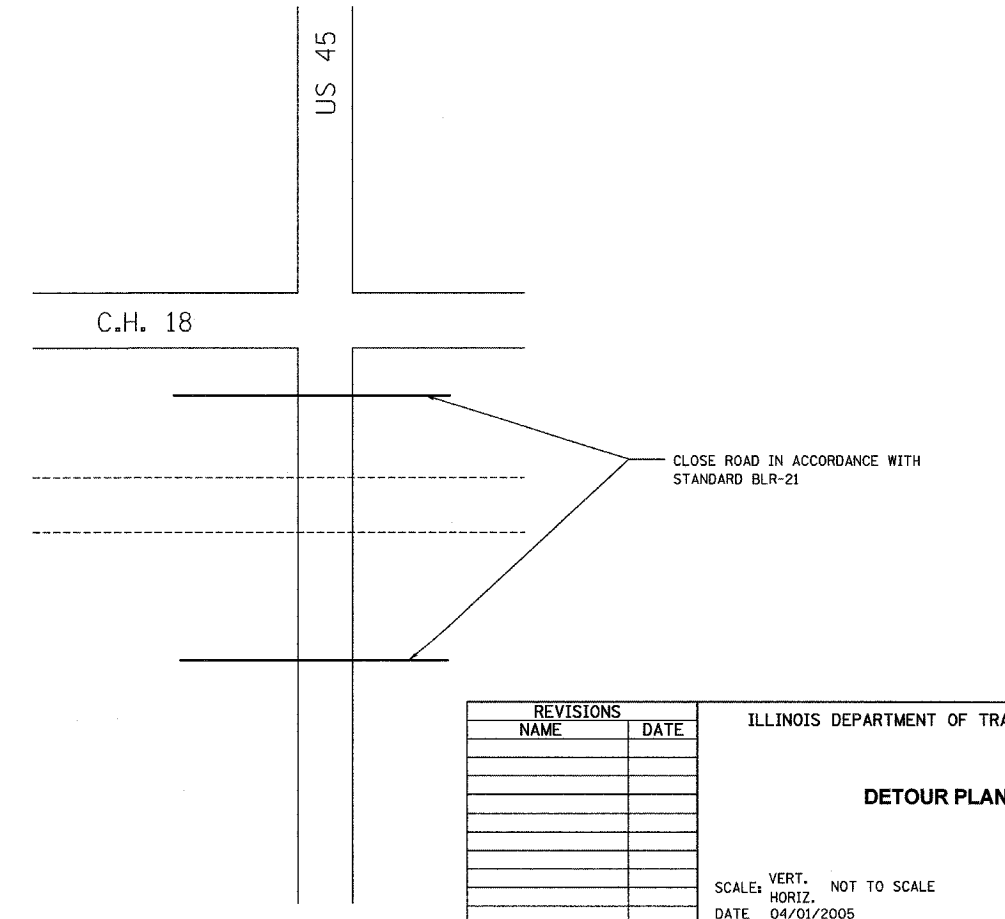

ILLINOIS DEPARTMENT OF TRANSPORTATION

DETOUR PLAN

SCALE: VERT. NOT TO SCALE
 HORIZ. NOT TO SCALE
 DATE: 04/01/2005

DRAWN BY: RLH
 CHECKED BY: MED

TUC PROJ #197022-5
 HA DETOUR PLAN.GPJ

F.A.S. RTE.	SECTION	COUNTY	TOTAL SHEETS	SHEET NO.
642	99-00124-01-PV	COLES	157	61
STA. 100+00		TO STA. 121+16		
FED. ROAD DIST. NO.	ILLINOIS	FED. AID PROJECT		

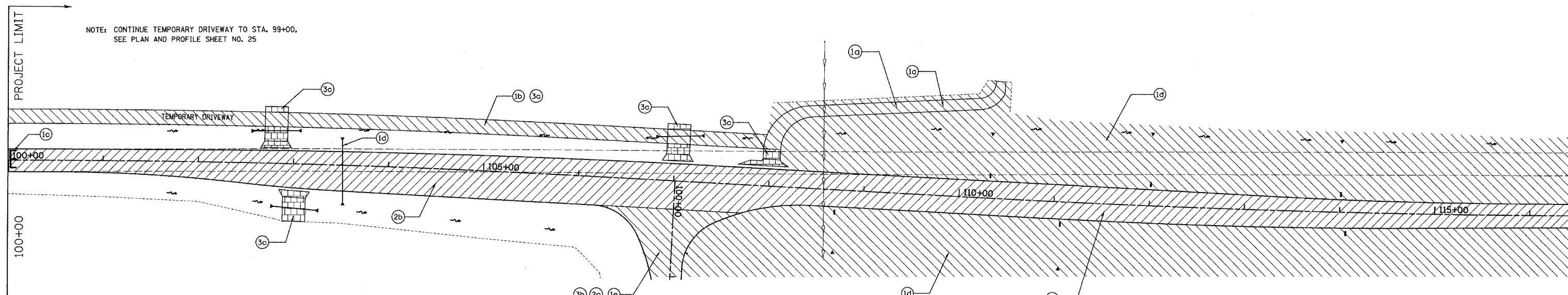

STAGE 1, STA 100+00 TO STA 133+00

- 1a) CONSTRUCT PERMANENT ENTRANCE WITH TEMPORARY CONNECTIONS FOR RESIDENTS, LEFT STA 110+00
- 1b) CONSTRUCT TEMPORARY DRIVEWAY LEFT STA 99+00 TO STA 107+01.
- 1c) CLOSE WEST LEG OF C.H. 18., STA 100+00 TO U.S. ROUTE 45.
- 1d) CONSTRUCT CULVERTS, EMBANKMENT, MSE WALL AND DITCHES, STA 100+00 TO STA 133+00 (CH 18)
- 1e) CONSTRUCT CULVERTS, EMBANKMENT, AND DITCHES, STA 100+00 TO STA 116+00 (JUGHANDLE)
- 1f) CONSTRUCT TEMPORARY GEOTEXTILE RETAINING WALL
- 1g) CLOSE EXISTING CO. RD. 600E
- 1h) CONSTRUCT TEMPORARY CULVERT ACROSS EXISTING C.H. 18 STA. 125+00 LEFT.
- 1i) REMOVE EXISTING ISLANDS, PATCH AND STRIPE NORTH HALF OF PAVEMENT FOR 2 DIRECTION OPERATION

STAGE 1 CONSTRUCTION

STAGE 2, STA 100+00 TO STA 133+00

- 2a) CONSTRUCT GRADE SEPARATION STRUCTURE STA 120+28 TO STA 123+44.
- 2b) C.H. 18, CONSTRUCT REMAINING CULVERTS, EARTHWORK AND ALL ROADWAY AND SHOULDER PAVING STA 100+00 TO STA 133+00
- 2c) JUGHANDLE, CONSTRUCT REMAINING CULVERTS, EARTHWORK, AND ALL ROADWAY AND SHOULDER PAVING
- 2d) REMOVE OLD CH 18 PAVEMENT, WEST SIDE OF U.S. 45 INTERSECTION

STAGE 2 CONSTRUCTION

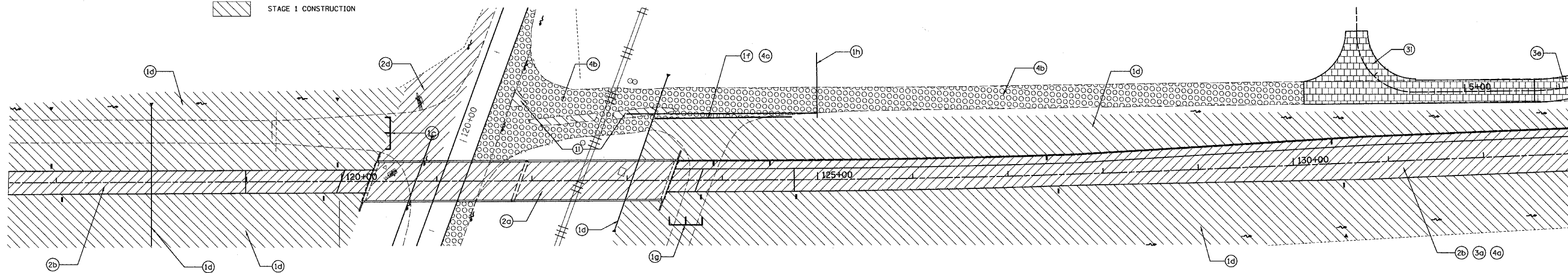

STAGE 3, STA 100+00 TO STA 133+00

- 3a) OPEN NEW C.H. 18 TO LOCAL TRAFFIC ONLY.
- 3b) OPEN JUGHANDLE TO TRAFFIC FROM U.S. 45 TO C.H. 18.
- 3c) REMOVE TEMPORARY DRIVEWAY STA 99+00 TO STA 108+00 LEFT, SHAPE DITCH AND CONSTRUCT PERMANENT ENTRANCE CONNECTION.
- 3e) RESURFACE EXISTING C.H. 18 PAVEMENT TO REMAIN IN PLACE AS A COMMERCIAL ENTRANCE STA 130+14 TO STA 132+60.

STAGE 3 CONSTRUCTION

STAGE 4, STA 100+00 TO STA 133+00

- 4a) OPEN NEW C.H. 18 TO ALL TRAFFIC.
- 4b) CLOSE EXISTING C.H. 18 AT U.S. 45. REMOVE EXISTING C.H. 18 PCC PAVEMENT STA 121+51 TO STA 129+00. REMOVE EXISTING RAILROAD CROSSING.
- 4c) REMOVE TEMPORARY GEOTEXTILE RETAINING WALL SYSTEM, COMPLETE BRIDGE CONE SLOPE

STAGE 4 CONSTRUCTION

REVISIONS	
NAME	DATE

ILLINOIS DEPARTMENT OF TRANSPORTATION

STAGING PLAN

SCALE: VERT. 1" = 50'
HORIZ. 1" = 50'
DATE 04/01/2005

DRAWN BY SJF
CHECKED BY MED

C.H. 18, STA. 100+00 TO STA. 133+00

TUG PROJ. #3107022-5
PLAN STAGING.dgn
04/01/2005

F.A.S. RTE.	SECTION	COUNTY	TOTAL SHEETS	SHEET NO.
642	99-00124-01-PV	COLES	157	62
STA. 100+00		TO STA. 121+16		
FED. ROAD DIST. NO.	ILLINOIS	FED. AID PROJECT		

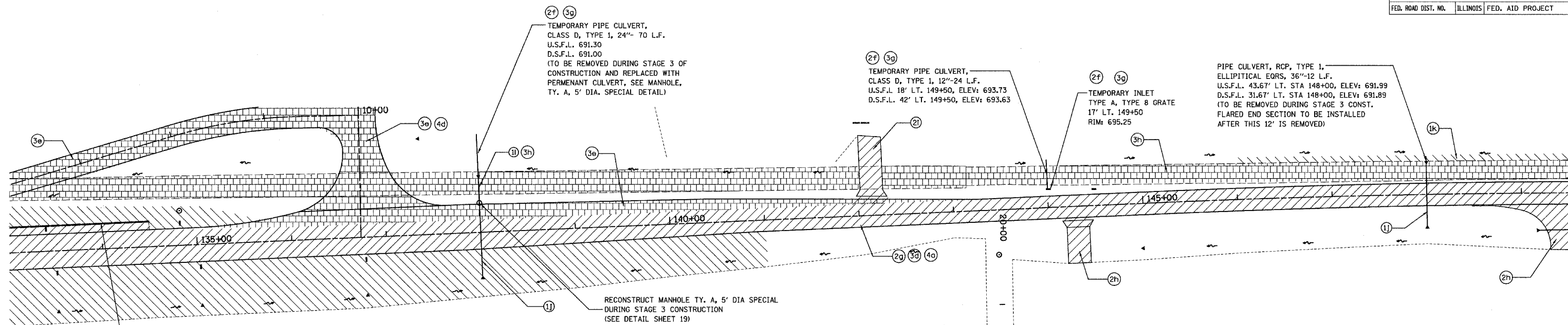

STAGE 1, STA 133+00 TO STA 166+00

- 1j) CONSTRUCT CULVERTS, EMBANKMENT, MSE WALL AND DITCHES, STA 133+00 TO STA 141+00 (CH 18)
- 1k) WIDEN EXISTING C.H. 18, STA 146+00 TO STA 159+00 LEFT
- 1l) NOTE: C.H. 18 SHALL REMAIN OPEN AT ALL TIMES EAST OF U.S. ROUTE 45.

STAGE 1 CONSTRUCTION

STAGE 2, STA 133+00 TO STA 166+00

- 2a) CLOSE C.H. 18 TO THROUGH TRAFFIC FROM U.S. ROUTE 45 TO C.RD. 700E.
- 2f) CONSTRUCT TEMPORARY INLETS BETWEEN EXISTING AND PROPOSED C.H.18 PAVEMENTS, CONSTRUCT TEMPORARY CULVERTS ACROSS EXISTING C.H. 18, CONSTRUCT TEMPORARY DITCHES BETWEEN EXISTING C.H. 18 AND PROPOSED C.H. 18 STA 144+50 TO STA 158+50 LEFT.
- 2g) C.H. 18, CONSTRUCT REMAINING CULVERTS, EARTHWORK AND ALL ROADWAY PAVING STA 133+00 TO STA 166+00, EXCEPT THE AREA LEFT OF PROPOSED C.H. 18 THAT CAN NOT BE DISTURBED IN ORDER TO MAINTAIN TRAFFIC ON EXISTING C.H. 18, INCLUDING THE RIGHT TURN LANE STATION 136+00 TO 142+00. (SEE TEMPORARY CROSS-SECTION LINE) CONSTRUCT IN STAGES AS NECESSARY TO MAINTAIN TRAFFIC
- 2h) CONSTRUCT COMMERCIAL ENTRANCES, LOGAN STREET RETURN, AND SHOULDER PAVING ADJACENT TO EAST BOUND LANE. CONSTRUCT IN STAGES AS NECESSARY TO MAINTAIN TRAFFIC.
- 2i) CONSTRUCT ENTRANCE AT STA 142+14 LEFT TO BE USED AS A TEMPORARY TRUCK ENTRANCE FOR MASTERFOODS USA

STAGE 2 CONSTRUCTION

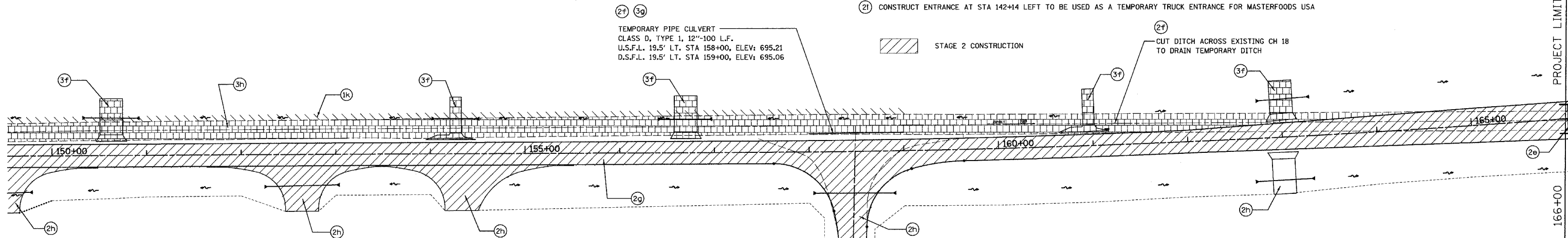

STAGE 3, STA 133+00 TO STA 166+00

- 3d) OPEN NEW C.H. 18 TO LOCAL TRAFFIC. CLOSE EXISTING C.H. 18 EAST OF STA. 130+50
- 3e) CONSTRUCT THE NEW ENTRANCE AT STA 136+73 INCLUDING THE RIGHT TURN LANE.
- 3f) CONSTRUCT ENTRANCES ADJACENT TO WEST BOUND C.H. 18. CONSTRUCT IN STAGES AS NECESSARY TO MAINTAIN TRAFFIC.
- 3g) REMOVE AND SALVAGE TEMPORARY INLETS AND CULVERTS STA 125+00 TO STA 158+50 LEFT.
- 3h) C.H. 18, REMOVE EXISTING PCC PAVEMENT STA 132+60 TO STA 143+13 LEFT. OBLITERATE REMAINING EXISTING C.H. 18 ROADWAY, STA 143+13 TO STA 161+25, COMPLETE CONSTRUCTION OF WEST BOUND SHOULDERS AND DITCHES STA 137+00 TO STA 166+00 LEFT.

STAGE 3 CONSTRUCTION

STAGE 4, STA 133+00 TO STA 166+00

- 4a) OPEN C.H. TO ALL TRAFFIC
- 4d) OPEN NEW ENTRANCE AT 136+73

STAGE 4 CONSTRUCTION

REVISIONS	
NAME	DATE

ILLINOIS DEPARTMENT OF TRANSPORTATION

STAGING PLAN

SCALE: VERT. 1" = 50'
HORIZ. 1" = 50'
DATE 04/01/2005

DRAWN BY SJF
CHECKED BY MED

C.H. 18, STA. 133+00 TO STA. 166+00

F.A.S. RTE.	SECTION	COUNTY	TOTAL SHEETS	SHEET NO.
642	99-00124-01-PV	COLES	157	63
STA. 100+00		TO STA. 121+16		
FED. ROAD DIST. NO.	ILLINOIS	FED. AID PROJECT		

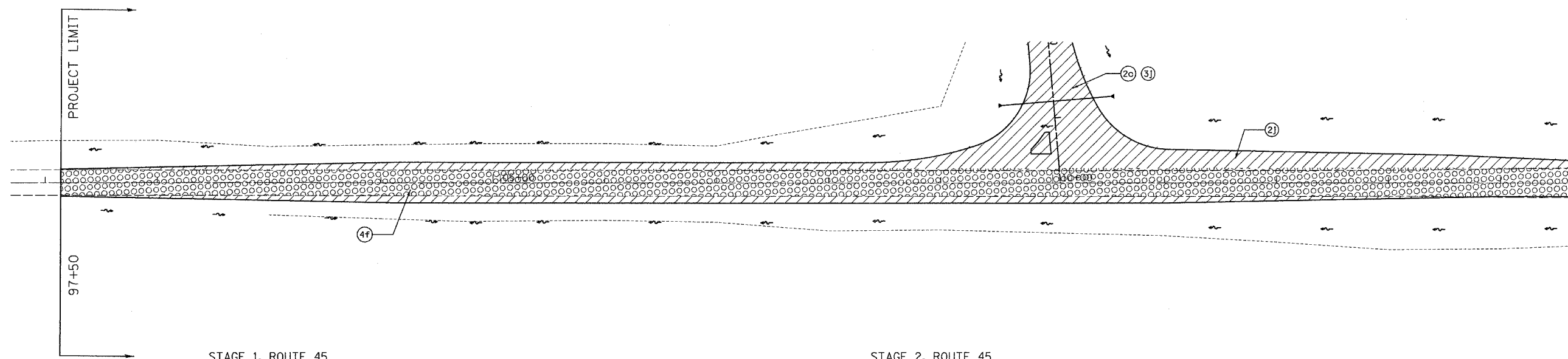

STAGE 1, ROUTE 45

- 1c) CLOSE C.H. 18 WEST OF RTE 45

STAGE 1 CONSTRUCTION

STAGE 2, ROUTE 45

- 2c) JUGHANDLE, CONSTRUCT REMAINING CULVERTS, EARTHWORK, AND ALL ROADWAY AND SHOULDER PAVING
- 2j) CONSTRUCT CULVERTS, EMBANKMENT, WIDENING, SHOULDERS AND DITCHES STA 97+50 TO 127+25, US RTE 45

NOTE: LEAVE SHOULDER MATERIAL 1/2" BELOW FINISHED GRADE AND BRING UP TO FINISHED GRADE WHEN SURFACE COURSE IS PLACED IN STAGE 4, LT & RT AND STA 121+75 TO 127+25 RT

STAGE 2 CONSTRUCTION

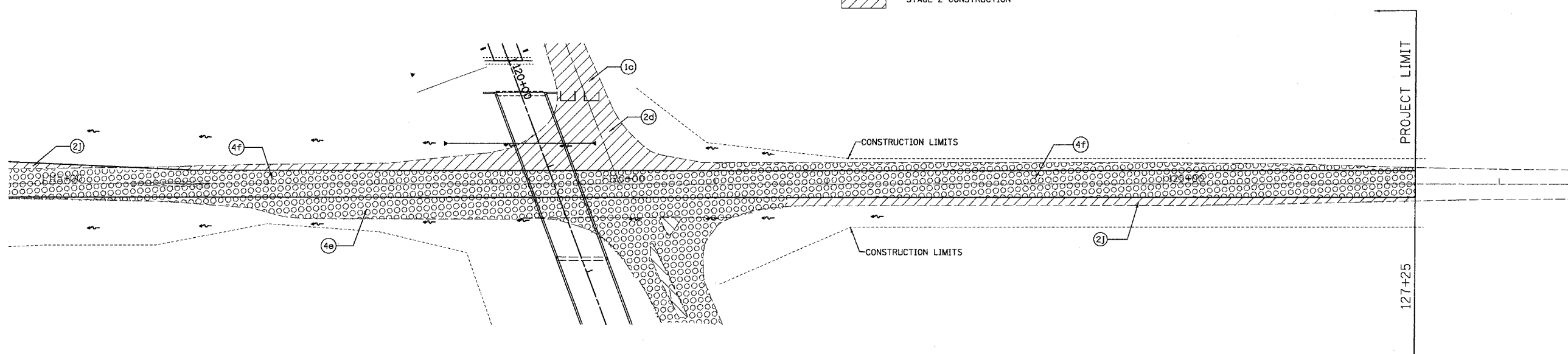

STAGE 3, ROUTE 45

- 3j) OPEN JUGHANDLE TO TRAFFIC FROM U.S. 45 TO C.H. 18.

STAGE 3 CONSTRUCTION

STAGE 4, ROUTE 45

- 4e) REMOVE INTERSECTION AND TURN LANE PAVEMENT AT THE EXISTING RTE 45 AND CH 18 INTERSECTION, EAST SIDE
- 4f) RTE 45, CONSTRUCT REMAINING CULVERTS, EARTHWORK, DITCH REGRADING, AND ALL ROADWAY AND SHOULDER PAVING

STAGE 4 CONSTRUCTION

REVISIONS	
NAME	DATE

ILLINOIS DEPARTMENT OF TRANSPORTATION

STAGING PLAN

SCALE: VERT. 1" = 50'
HORIZ. 1" = 50'
DATE 04/01/2005

DRAWN BY SJF
CHECKED BY MED

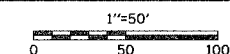

F.A.S. RTE.	SECTION	COUNTY	TOTAL SHEETS	SHEET NO.
642	99-00124-01-PV	COLES	157	64
STA. 100+00		TO STA. 111+00		
FED. ROAD DIST. NO.		ILLINOIS	FED. AID PROJECT	

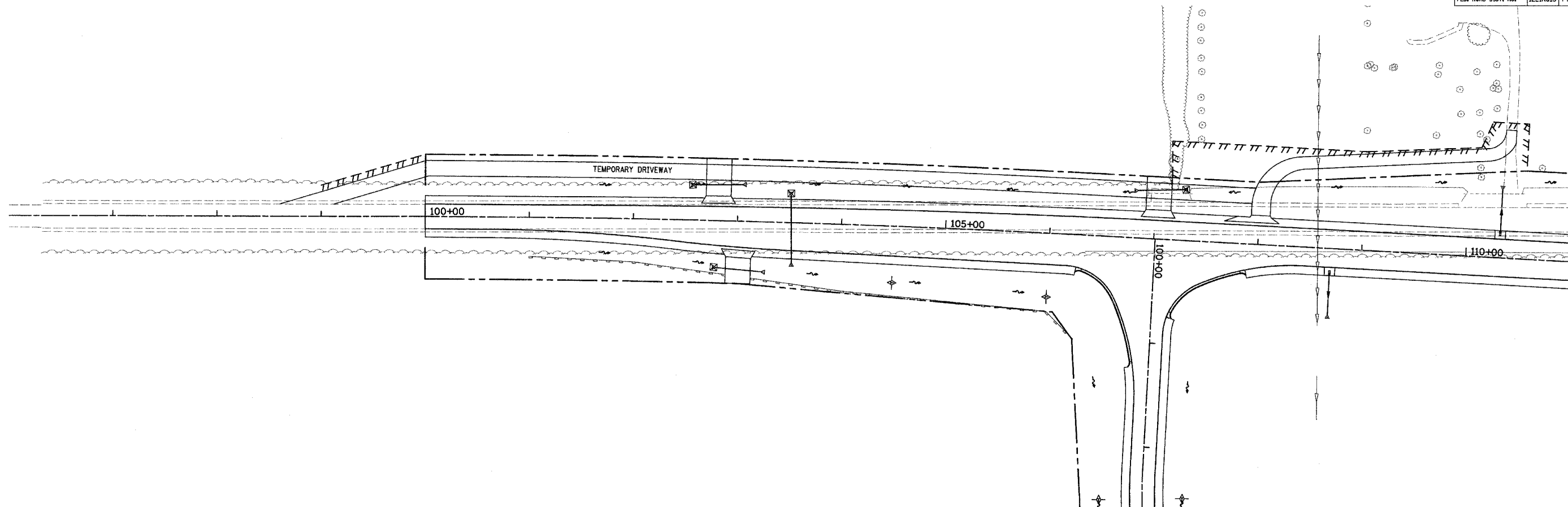

TEMPORARY DITCH CHECKS	
LOCATION	EACH
104+50, RT	1
106+00, RT	1
TOTAL THIS SHEET	2

INLET AND PIPE PROTECTION	
STATION	EACH
102+56, LT	1
102+78, RT	1
103+51, LT	1
107+29, LT	1
TOTAL ON THIS SHEET	4

PERIMETER EROSION BARRIER	
STATION TO STATION	LIN FT
101+00 RT - 102+00 RT	99.7
102+00 RT - 102+88 RT	88.5
103+14 RT - 104+00 RT	86.1
104+00 RT - 106+00 RT	199.1
106+00 RT - 106+27 RT	37.1
TOTAL THIS SHEET	510.5

- ☒ TEMPORARY INLET PROTECTION
- ⊕ TEMPORARY DITCH CHECK
- PERIMETER EROSION BARRIER
- ▨ EROSION CONTROL BLANKET
- ▩ RIP RAP
- SEEDING CLASS 7

INTENDED SEQUENCE

- 1) PLACE PERIMETER EROSION CONTROL BARRIER PRIOR TO COMMENCEMENT OF ANY WORK. SEE STD. 280001
- 2) CONSTRUCT EARTHWORK, DITCHES FIRST. (MAXIMUM 10 ACRES DISTURBED AT ONE TIME PRIOR TO SEEDING. SEE ART. 202 & 280)
- 3) PLACE AND MAINTAIN TEMPORARY AND PERMANENT EROSION CONTROLS AS WORK PROGRESSES, SEED EVERY 7 DAYS. SEE ART. 280
- 4) FINAL SHAPE, GRADE, AND PAVE ROADWAY
- 5) PLACE REMAINING PERMANENT EROSION CONTROLS.

REVISIONS	
NAME	DATE

ILLINOIS DEPARTMENT OF TRANSPORTATION

EROSION CONTROL PLAN

SCALE: VERT. _____
 HORIZ. 1" = 50'
 DATE 04/01/2005

DRAWN BY RLH
 CHECKED BY MED

TUG PROJ. #3197022-5
 \SHEET\EROSION-WL.dgn
 04/01/2005

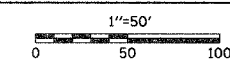

F.A.S. RTE.	SECTION	COUNTY	TOTAL SHEETS	SHEET NO.
642	99-00124-01-PV	COLES	157	65
STA. 111+00		TO STA. 126+00		
FED. ROAD DIST. NO.	ILLINOIS	FED. AID PROJECT		

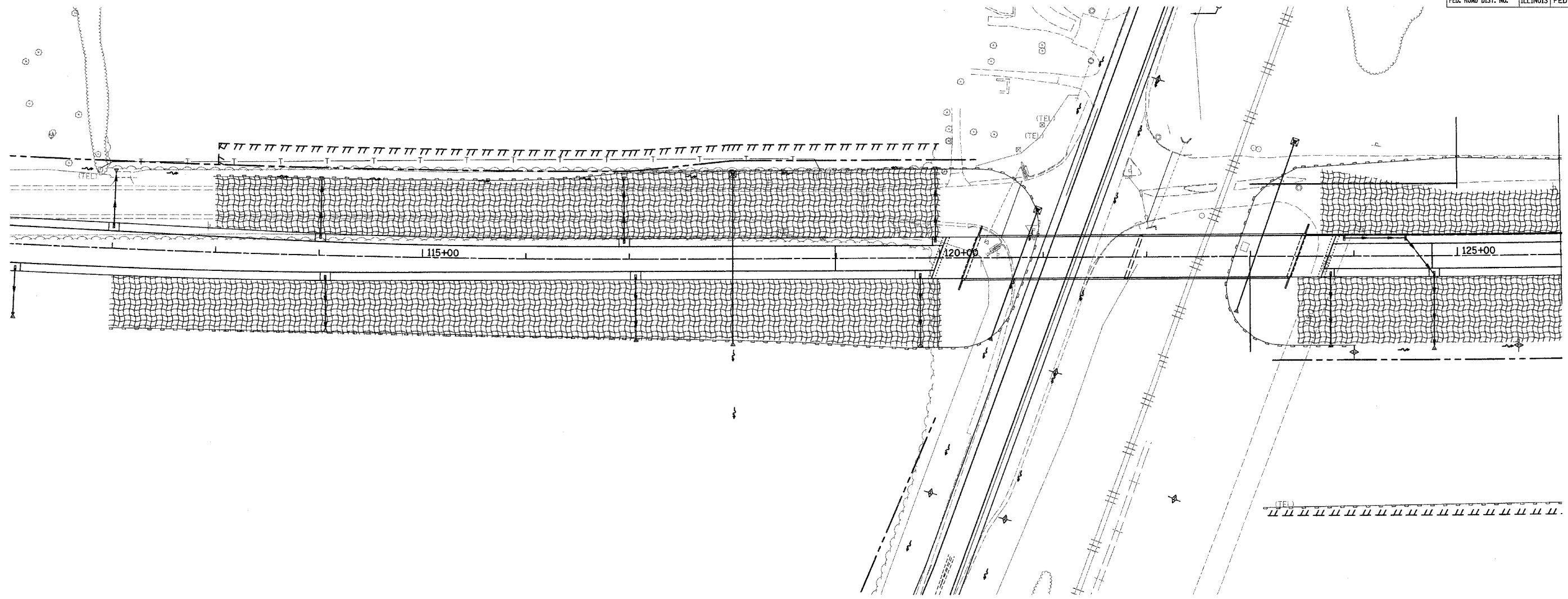

EROSION CONTROL BLANKET	
STATION TO STATION	SQ YD
112+00 RT - 120+00 RT	5353.3
113+00 LT - 120+00 LT	4997.8
123+45 RT - 126+00 RT	2151.3
123+45 LT - 126+00 LT	1437.3
TOTAL THIS SHEET	13939.7

TEMPORARY DITCH CHECKS	
LOCATION	EACH
124+00, RT	1
125+50, RT	1/2
TOTAL THIS SHEET	2

INLET AND PIPE PROTECTION	
STATION	EACH
118+00, LT	1
120+94, LT	1
123+43, LT	1
TOTAL ON THIS SHEET	3

PERIMETER EROSION BARRIER	
STATION TO STATION	LIN FT
112+00 RT - 117+95 RT	597.7
112+96 LT - 116+43 LT	345.2
116+43 LT - 116+93 LT	49.6
116+93 LT - 119+75 LT	281.8
117+95 RT - 119+74 RT	179.2
119+75 LT - 120+88	184.0
117+95 RT - 119+74 RT	179.2
119+74 RT - 120+88	164.9
122+84 - 124+01 RT	187.8
122+84 - 123+45 LT	110.6
123+45 LT - 125+00 LT	154.7
125+00 LT - 126+00 LT	99.2
123+12 RT - 126+00 RT	291.5
TOTAL THIS SHEET	2825.4

- TEMPORARY INLET PROTECTION
- TEMPORARY DITCH CHECK
- PERIMETER EROSION BARRIER
- EROSION CONTROL BLANKET
- RIP RAP
- SEEDING CLASS 7

INTENDED SEQUENCE

- 1) PLACE PERIMETER EROSION CONTROL BARRIER PRIOR TO COMMENCEMENT OF ANY WORK. SEE STD. 280001
- 2) CONSTRUCT EARTHWORK, DITCHES FIRST. (MAXIMUM 10 ACRES DISTURBED AT ONE TIME PRIOR TO SEEDING. SEE ART. 202 & 280)
- 3) PLACE AND MAINTAIN TEMPORARY AND PERMANENT EROSION CONTROLS AS WORK PROGRESSES, SEED EVERY 7 DAYS. SEE ART. 280
- 4) FINAL SHAPE, GRADE, AND PAVE ROADWAY
- 5) PLACE REMAINING PERMANENT EROSION CONTROLS.

REVISIONS	
NAME	DATE

ILLINOIS DEPARTMENT OF TRANSPORTATION

EROSION CONTROL PLAN

SCALE: VERT. HORIZ. 1" = 50'
DATE 04/01/2005

DRAWN BY RLH
CHECKED BY MED

TUC PROJ #107022-5
SHEET EROSION-MCGR
04/01/2005

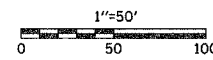

F.A.S. RTE.	SECTION	COUNTY	TOTAL SHEETS	SHEET NO.
642	99-00124-01-PV	COLES	157	66
STA. 126+00		TO STA. 141+00		
FED. ROAD DIST. NO.		ILLINOIS FED. AID PROJECT		

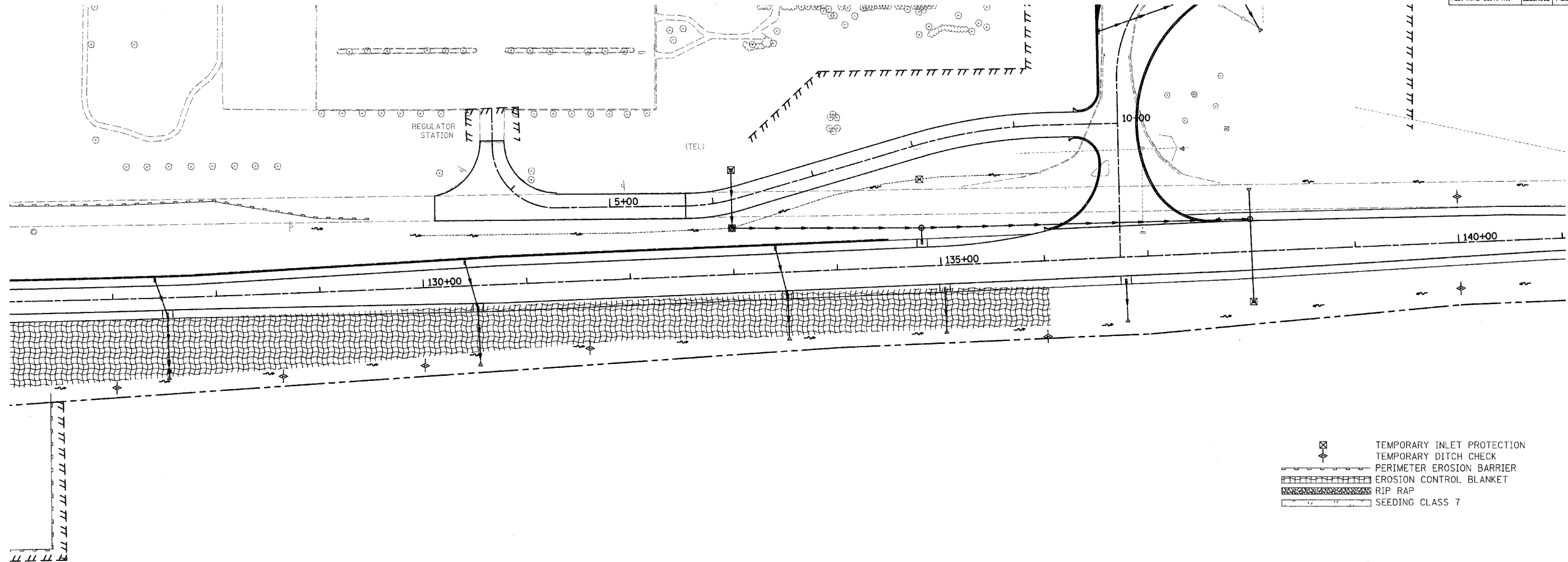

- ⊠ TEMPORARY INLET PROTECTION
- ⊕ TEMPORARY DITCH CHECK
- ▬ PERIMETER EROSION BARRIER
- ▨ EROSION CONTROL BLANKET
- ▩ RIP RAP
- ▭ SEEDING CLASS 7

▨ EROSION CONTROL BLANKET	
STATION TO STATION	SQ YD
126+00 RT - 136+00 RT	5803.3

⊕ TEMPORARY DITCH CHECKS	
LOCATION	EACH
127+00, RT	1
128+50, RT	1
130+00, RT	1
131+50, RT	1
136+00, RT	1
140+00, LT	1
140+00, RT	1
TOTAL THIS SHEET	7

▬ PERIMETER EROSION BARRIER	
STATION TO STATION	LIN FT
126+00 RT - 126+43 RT	43.6
126+00 LT - 129+50 LT	349.9
126+43 RT - 126+45 RT	154.2
TOTAL THIS SHEET	547.7

⊠ INLET AND PIPE PROTECTION	
STATION	EACH
133+00, LT	1
133+01, LT	1
133+07, LT	1
134+83, LT	1
138+00, RT	1
TOTAL ON THIS SHEET	5

- INTENDED SEQUENCE**
- 1) PLACE PERIMETER EROSION CONTROL BARRIER PRIOR TO COMMENCEMENT OF ANY WORK. SEE STD. 280001
 - 2) CONSTRUCT EARTHWORK, DITCHES FIRST. (MAXIMUM 10 ACRES DISTURBED AT ONE TIME PRIOR TO SEEDING. SEE ART. 202 & 280)
 - 3) PLACE AND MAINTAIN TEMPORARY AND PERMANENT EROSION CONTROLS AS WORK PROGRESSES, SEED EVERY 7 DAYS. SEE ART. 280
 - 4) FINAL SHAPE, GRADE, AND PAVE ROADWAY
 - 5) PLACE REMAINING PERMANENT EROSION CONTROLS.

REVISIONS	
NAME	DATE

ILLINOIS DEPARTMENT OF TRANSPORTATION

EROSION CONTROL PLAN

SCALE: VERT. _____
 HORIZ. 1" = 50'
 DATE 04/01/2005

DRAWN BY RLH
 CHECKED BY MED

TUC PROJ. #13197022-5
 ...SHEET EROSION-W.dgn
 04/01/2005

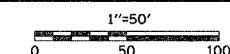

F.A.S. RTE.	SECTION	COUNTY	TOTAL SHEETS	SHEET NO.
642	99-00124-01-PV	COLES	157	67
STA. 141+00		TO STA. 156+00		
FED. ROAD DIST. NO.		ILLINOIS FED. AID PROJECT		

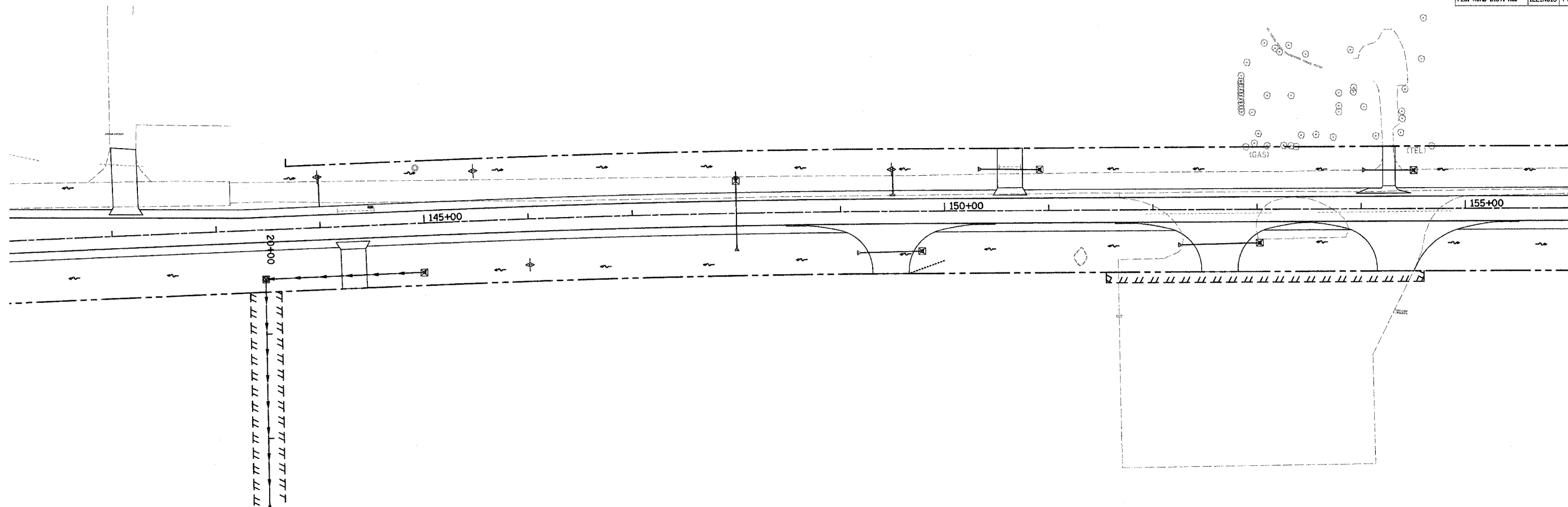

INLET AND PIPE PROTECTION	
STATION	EACH
143+46, RT	1
144+98, RT	1
148+00, LT	1
149+78, LT	1
150+91, LT	1
153+02, LT	1
154+50, LT	1
TOTAL ON THIS SHEET	7

TEMPORARY DITCH CHECKS	
LOCATION	EACH
144+00, LT	1
145+50, LT	1
146+00, RT	1
149+50, LT	1
TOTAL THIS SHEET	4

- TEMPORARY INLET PROTECTION
- TEMPORARY DITCH CHECK
- PERIMETER EROSION BARRIER
- EROSION CONTROL BLANKET
- RIP RAP
- SEEDING CLASS 7

INTENDED SEQUENCE

- 1) PLACE PERIMETER EROSION CONTROL BARRIER PRIOR TO COMMENCEMENT OF ANY WORK. SEE STD. 280001
- 2) CONSTRUCT EARTHWORK, DITCHES FIRST. (MAXIMUM 10 ACRES DISTURBED AT ONE TIME PRIOR TO SEEDING. SEE ART. 202 & 280)
- 3) PLACE AND MAINTAIN TEMPORARY AND PERMANENT EROSION CONTROLS AS WORK PROGRESSES, SEED EVERY 7 DAYS. SEE ART. 280
- 4) FINAL SHAPE, GRADE, AND PAVE ROADWAY
- 5) PLACE REMAINING PERMANENT EROSION CONTROLS.

REVISIONS	
NAME	DATE

ILLINOIS DEPARTMENT OF TRANSPORTATION

EROSION CONTROL PLAN

SCALE: VERT. DRAWN BY RLH
 HORIZ. 1" = 50'
 DATE 04/01/2005 CHECKED BY MED

TUC PROJ #3187022-5
 11 SHEET EROSION-W/CDM
 04/01/2005

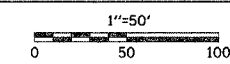

F.A.S. RTE.	SECTION	COUNTY	TOTAL SHEETS	SHEET NO.
642	99-00124-01-PV	COLES	157	68
STA. 156+00		TO STA. 171+00		
FED. ROAD DIST. NO.	ILLINOIS	FED. AID PROJECT		

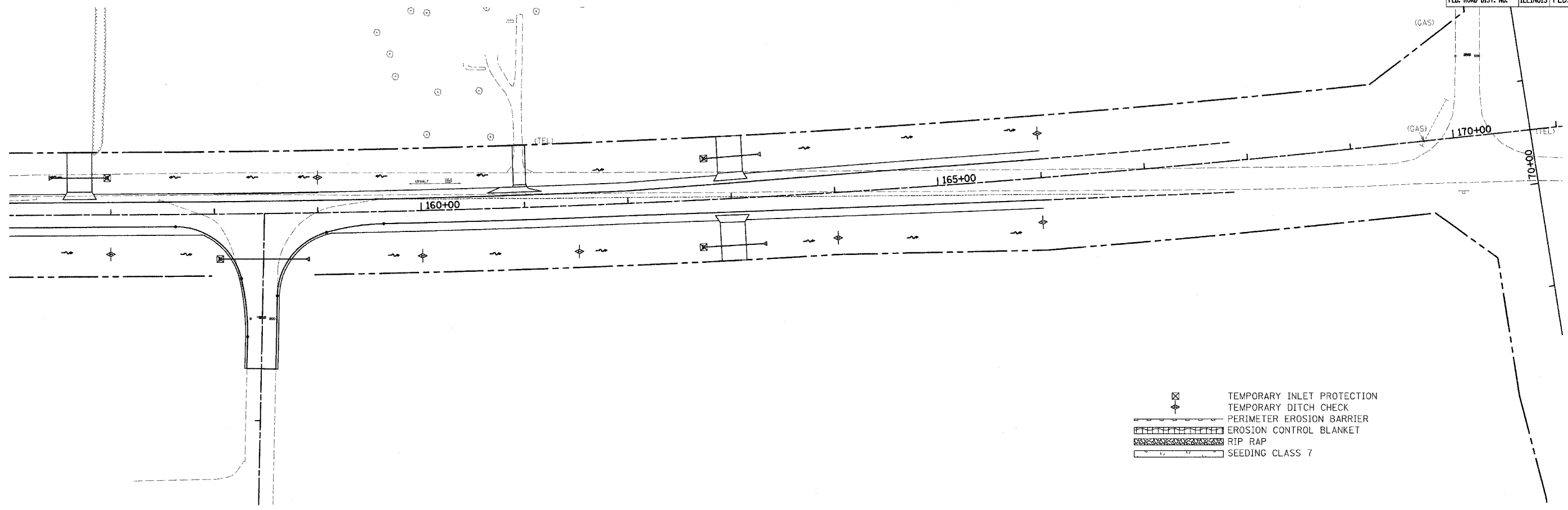

- TEMPORARY INLET PROTECTION
- TEMPORARY DITCH CHECK
- PERIMETER EROSION BARRIER
- EROSION CONTROL BLANKET
- RIP RAP
- SEEDING CLASS 7

TEMPORARY DITCH CHECKS	
LOCATION	EACH
157+00, RT	1
159+00, LT	1
160+00, RT	1
161+50, RT	1
164+00, RT	1
166+00, RT	1
166+00, LT	1
TOTAL THIS SHEET	7

INLET AND PIPE PROTECTION	
STATION	EACH
156+97, LT	1
158+05, RT	1
162+71, RT	1
162+75, LT	1
TOTAL ON THIS SHEET	4

INTENDED SEQUENCE

- 1) PLACE PERIMETER EROSION CONTROL BARRIER PRIOR TO COMMENCEMENT OF ANY WORK. SEE STD. 280001
- 2) CONSTRUCT EARTHWORK, DITCHES FIRST. (MAXIMUM 10 ACRES DISTURBED AT ONE TIME PRIOR TO SEEDING. SEE ART. 202 & 280)
- 3) PLACE AND MAINTAIN TEMPORARY AND PERMANENT EROSION CONTROLS AS WORK PROGRESSES, SEED EVERY 7 DAYS. SEE ART. 280
- 4) FINAL SHAPE, GRADE, AND PAVE ROADWAY
- 5) PLACE REMAINING PERMANENT EROSION CONTROLS.

REVISIONS	
NAME	DATE

ILLINOIS DEPARTMENT OF TRANSPORTATION

EROSION CONTROL PLAN

SCALE: VERT. _____
 HORIZ. 1" = 50'
 DATE 04/01/2005

DRAWN BY RLH
 CHECKED BY MED

TUC PROJ #197022-5
 \SHEET EROSION-W.dgn
 01/01/2005

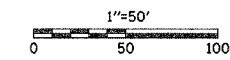

F.A.S. RTE.	SECTION	COUNTY	TOTAL SHEETS	SHEET NO.
642	99-00124-01-PV	COLES	157	69
STA. 100+00		TO STA. 116+58		
FED. ROAD DIST. NO.		ILLINOIS		FED. AID PROJECT

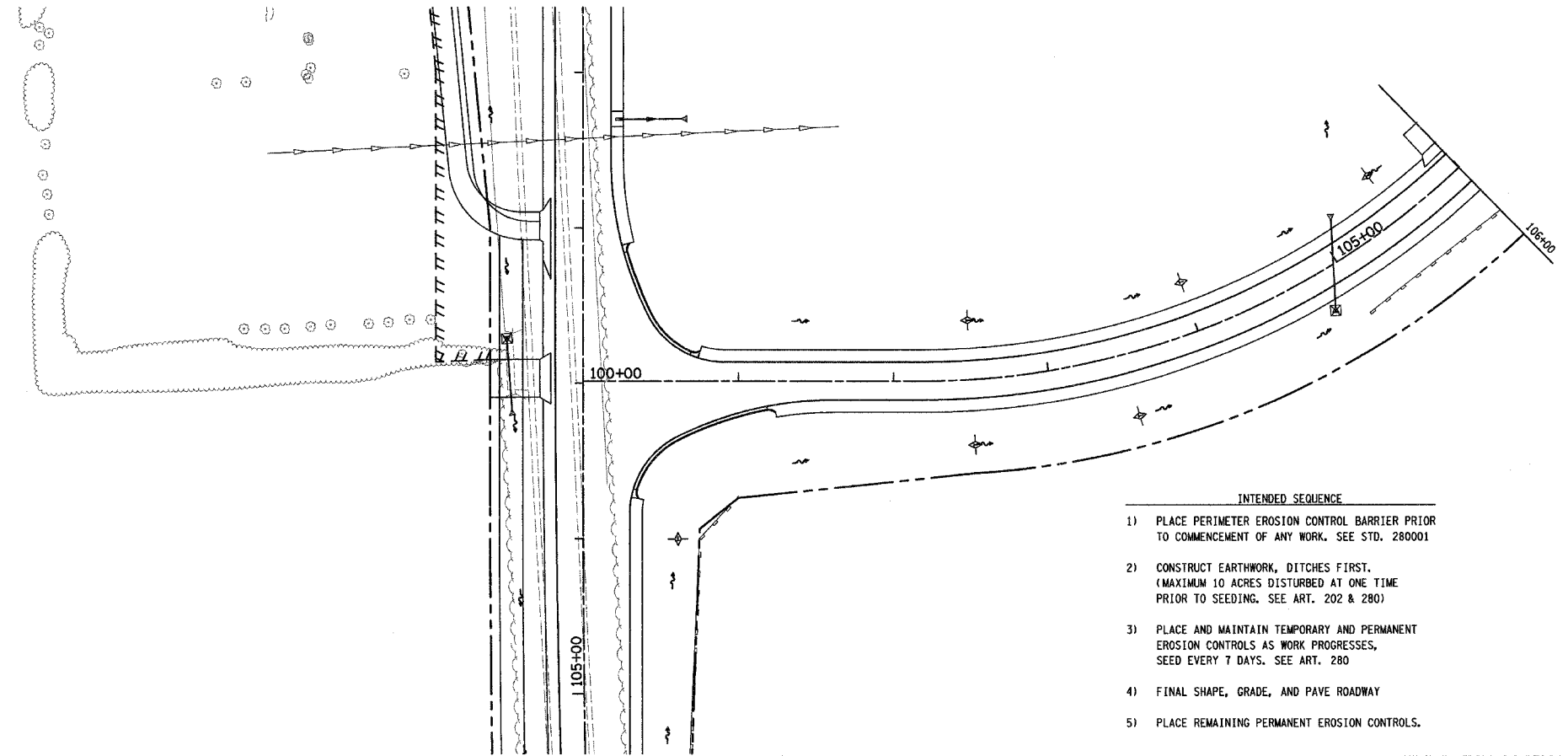

TEMPORARY DITCH CHECKS	
LOCATION	EACH
102+50, LT	1
102+50, RT	1
103+50, RT	1
104+00, LT	1
105+50, LT	1
107+00, LT	1
108+50, LT	1
110+00, LT	1
111+00, RT	1
111+50, LT	1
112+50, RT	1
113+00, LT	1
114+00, RT	1
114+50, LT	1
115+50, RT	1
TOTAL THIS SHEET	15

INLET AND PIPE PROTECTION	
STATION	EACH
104+85, RT	1
115+86, LT	1
TOTAL THIS SHEET	2

PERIMETER EROSION BARRIER	
STATION TO STATION	LN FT
105+00 RT - 109+00 RT	429.9

- INTENDED SEQUENCE**
- 1) PLACE PERIMETER EROSION CONTROL BARRIER PRIOR TO COMMENCEMENT OF ANY WORK. SEE STD. 280001
 - 2) CONSTRUCT EARTHWORK, DITCHES FIRST. (MAXIMUM 10 ACRES DISTURBED AT ONE TIME PRIOR TO SEEDING. SEE ART. 202 & 280)
 - 3) PLACE AND MAINTAIN TEMPORARY AND PERMANENT EROSION CONTROLS AS WORK PROGRESSES, SEED EVERY 7 DAYS. SEE ART. 280
 - 4) FINAL SHAPE, GRADE, AND PAVE ROADWAY
 - 5) PLACE REMAINING PERMANENT EROSION CONTROLS.

- TEMPORARY INLET PROTECTION
- TEMPORARY DITCH CHECK
- PERIMETER EROSION BARRIER
- EROSION CONTROL BLANKET
- RIP RAP
- SEEDING CLASS 7

- INTENDED SEQUENCE**
- 1) PLACE PERIMETER EROSION CONTROL BARRIER PRIOR TO COMMENCEMENT OF ANY WORK. SEE STD. 280001
 - 2) CONSTRUCT EARTHWORK, DITCHES FIRST. (MAXIMUM 10 ACRES DISTURBED AT ONE TIME PRIOR TO SEEDING. SEE ART. 202 & 280)
 - 3) PLACE AND MAINTAIN TEMPORARY AND PERMANENT EROSION CONTROLS AS WORK PROGRESSES, SEED EVERY 7 DAYS. SEE ART. 280
 - 4) FINAL SHAPE, GRADE, AND PAVE ROADWAY
 - 5) PLACE REMAINING PERMANENT EROSION CONTROLS.

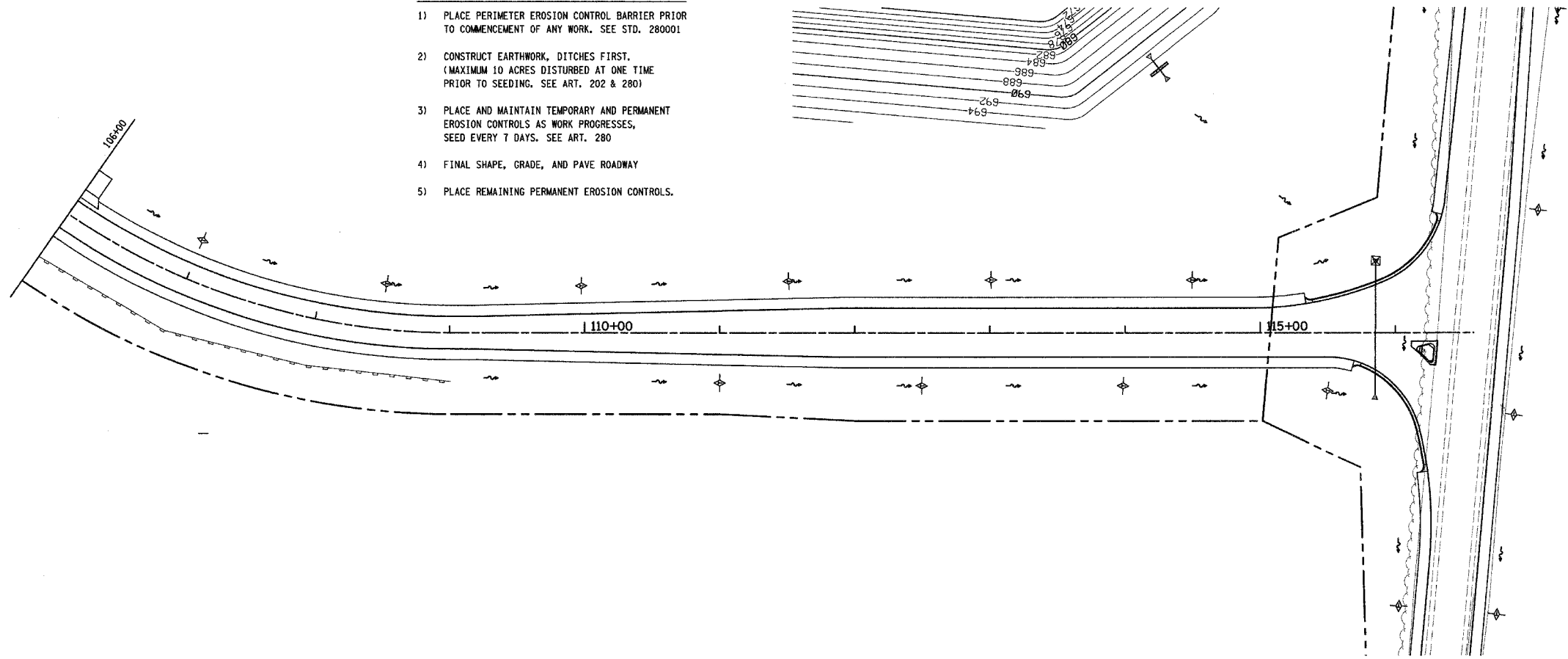

- TEMPORARY INLET PROTECTION
- TEMPORARY DITCH CHECK
- PERIMETER EROSION BARRIER
- EROSION CONTROL BLANKET
- RIP RAP
- SEEDING CLASS 7

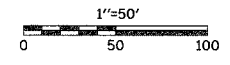

REVISIONS	
NAME	DATE

ILLINOIS DEPARTMENT OF TRANSPORTATION

EROSION CONTROL PLAN

SCALE: VERT. HORIZ. 1" = 50'
DATE 04/01/2005

DRAWN BY RLH
CHECKED BY MED

TUG PROJ. #1907022-5
SHEET EROSION W.dgn
04/01/2005

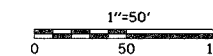

F.A.S. RTE.	SECTION	COUNTY	TOTAL SHEETS	SHEET NO.
642	99-00124-01-PV	COLES	157	70
STA. 98+00		TO STA. 117+50		
FED. ROAD DIST. NO.		ILLINOIS FED. AID PROJECT		

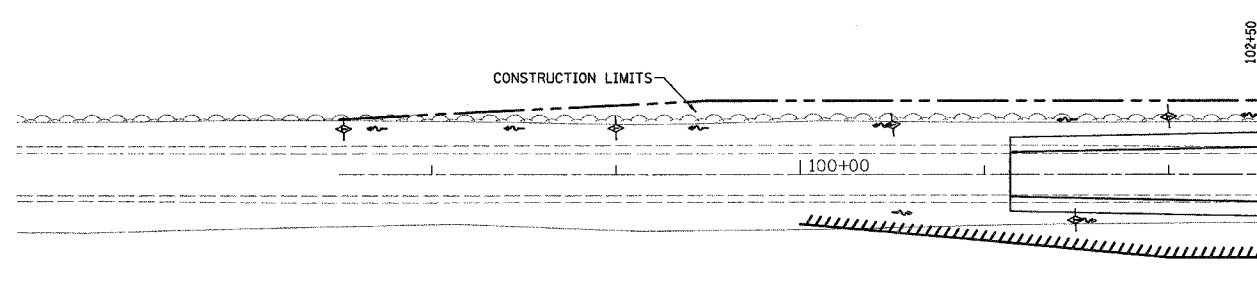

- INTENDED SEQUENCE**
- 1) PLACE PERIMETER EROSION CONTROL BARRIER PRIOR TO COMMENCEMENT OF ANY WORK. SEE STD. 280001
 - 2) CONSTRUCT EARTHWORK, DITCHES FIRST. (MAXIMUM 10 ACRES DISTURBED AT ONE TIME PRIOR TO SEEDING. SEE ART. 202 & 280)
 - 3) PLACE AND MAINTAIN TEMPORARY AND PERMANENT EROSION CONTROLS AS WORK PROGRESSES, SEED EVERY 7 DAYS. SEE ART. 280
 - 4) FINAL SHAPE, GRADE, AND PAVE ROADWAY
 - 5) PLACE REMAINING PERMANENT EROSION CONTROLS.

	TEMPORARY INLET PROTECTION
	TEMPORARY DITCH CHECK
	PERIMETER EROSION BARRIER
	EROSION CONTROL BLANKET
	RIP RAP
	SEEDING CLASS 7

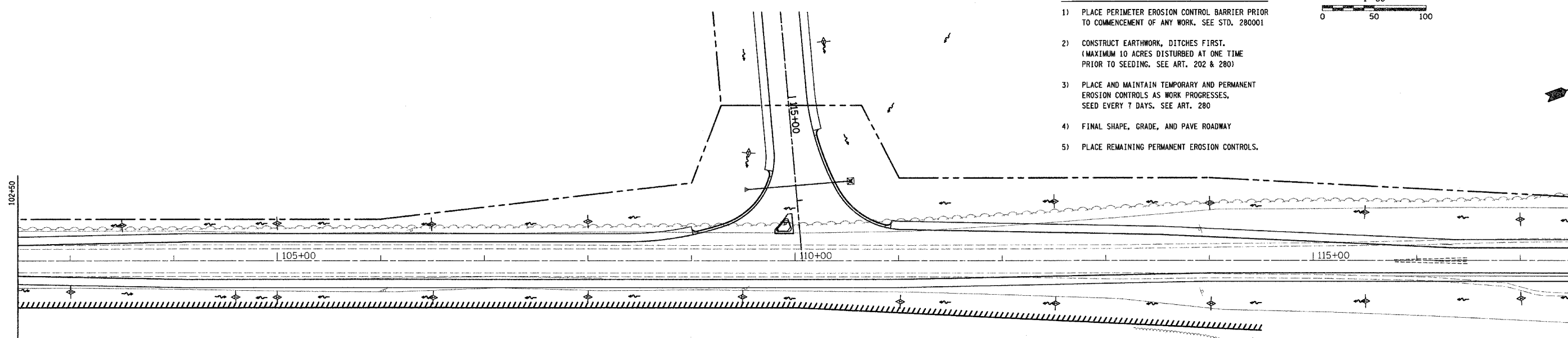
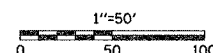

- INTENDED SEQUENCE**
- 1) PLACE PERIMETER EROSION CONTROL BARRIER PRIOR TO COMMENCEMENT OF ANY WORK. SEE STD. 280001
 - 2) CONSTRUCT EARTHWORK, DITCHES FIRST. (MAXIMUM 10 ACRES DISTURBED AT ONE TIME PRIOR TO SEEDING. SEE ART. 202 & 280)
 - 3) PLACE AND MAINTAIN TEMPORARY AND PERMANENT EROSION CONTROLS AS WORK PROGRESSES, SEED EVERY 7 DAYS. SEE ART. 280
 - 4) FINAL SHAPE, GRADE, AND PAVE ROADWAY
 - 5) PLACE REMAINING PERMANENT EROSION CONTROLS.



TEMPORARY DITCH CHECKS	
LOCATION	EACH
97+50, LT	1
99+00, LT	1
100+50, LT	1
101+50, RT	1
102+00, LT	1
103+00, RT	1
103+50, LT	1
104+50, RT	1
105+00, RT	1
105+00, LT	1
106+50, LT	1
106+50, RT	1
108+00, RT	1
108+00, LT	1
109+50, RT	1
111+00, RT	1
112+50, LT	1
112+50, RT	1
114+00, RT	1
114+00, LT	1
115+50, RT	1
115+50, LT	1
117+00, RT	1
117+00, LT	1
TOTAL THIS SHEET	24

	TEMPORARY INLET PROTECTION
	TEMPORARY DITCH CHECK
	PERIMETER EROSION BARRIER
	EROSION CONTROL BLANKET
	RIP RAP
	SEEDING CLASS 7

REVISIONS	
NAME	DATE

ILLINOIS DEPARTMENT OF TRANSPORTATION

EROSION CONTROL PLAN

SCALE: VERT. 1" = 50'
 HORIZ. 1" = 50'
 DATE 04/01/2005

DRAWN BY RLH
 CHECKED BY MED

TUC PROJ #1817022-5
 11 SHEETS TOTAL
 04/01/2005

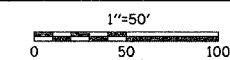

F.A.S. RTE.	SECTION	COUNTY	TOTAL SHEETS	SHEET NO.
642	99-00124-01-PV	COLES	157	71
STA. 117+50		TO STA. 132+50		
FED. ROAD DIST. NO.	ILLINOIS	FED. AID PROJECT		

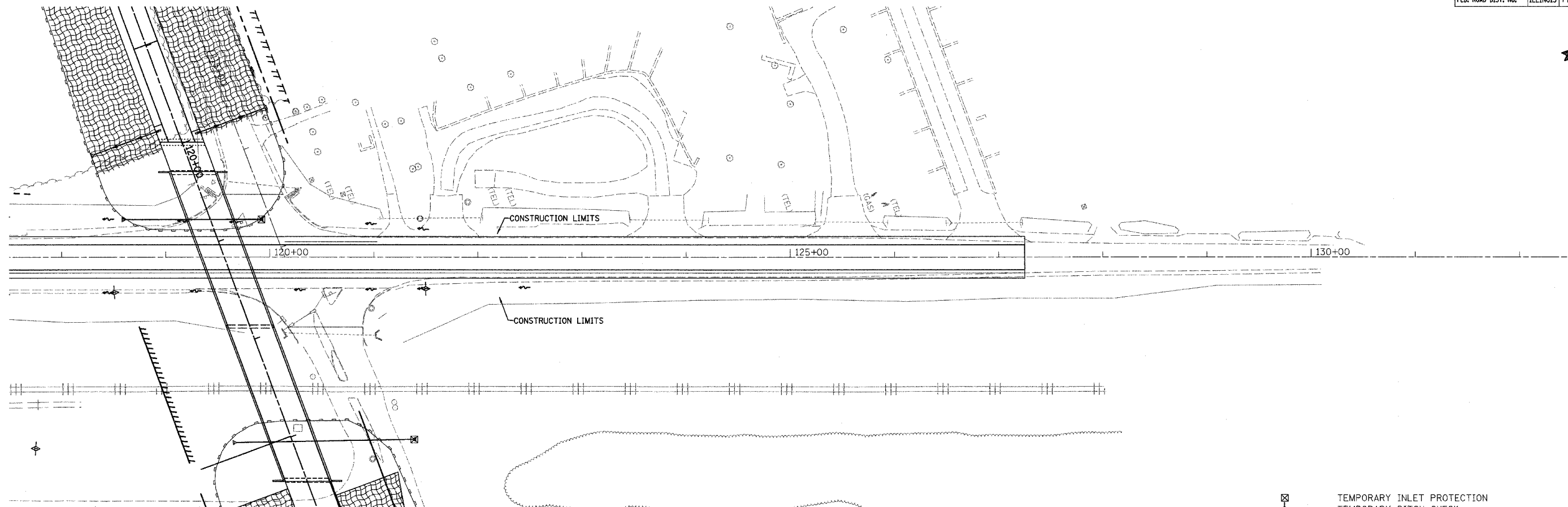

- TEMPORARY INLET PROTECTION
- TEMPORARY DITCH CHECK
- PERIMETER EROSION BARRIER
- EROSION CONTROL BLANKET
- RIP RAP
- SEEDING CLASS 7

TEMPORARY DITCH CHECKS	
LOCATION	EACH
118+50, RT	1
121+50, RT	1
TOTAL THIS SHEET	2

INTENDED SEQUENCE

- 1) PLACE PERIMETER EROSION CONTROL BARRIER PRIOR TO COMMENCEMENT OF ANY WORK. SEE STD. 280001
- 2) CONSTRUCT EARTHWORK, DITCHES FIRST. (MAXIMUM 10 ACRES DISTURBED AT ONE TIME PRIOR TO SEEDING. SEE ART. 202 & 280)
- 3) PLACE AND MAINTAIN TEMPORARY AND PERMANENT EROSION CONTROLS AS WORK PROGRESSES, SEED EVERY 7 DAYS. SEE ART. 280
- 4) FINAL SHAPE, GRADE, AND PAVE ROADWAY
- 5) PLACE REMAINING PERMANENT EROSION CONTROLS.

REVISIONS	
NAME	DATE

ILLINOIS DEPARTMENT OF TRANSPORTATION

EROSION CONTROL PLAN

SCALE: VERT. _____
 HORIZ. 1" = 50'
 DATE 04/01/2005

DRAWN BY RLH
 CHECKED BY MED

TUG PROJ. #9197022-5
 \\SHEET\EROSION-W.dgn
 04/01/2005

F.A.S. RTE.	SECTION	COUNTY	TOTAL SHEETS	SHEET NO.
642	99-00124-01-PV	COLES	157	72
STA.		TO STA.		
FED. ROAD DIST. NO.		ILLINOIS	FED. AID PROJECT	

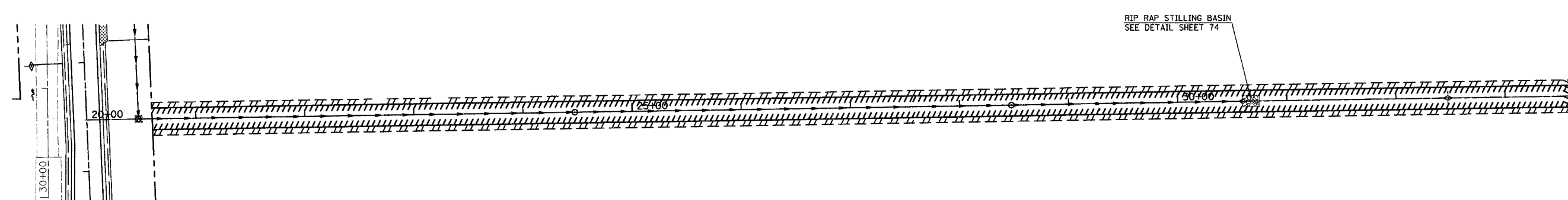

FILTER FABRIC FOR RIPRAP	
STATION	SQ YD
30+55	17.8

STONE RIPRAP, CLASS A4	
STATION	SQ YD
30+55	17.8

TEMPORARY DITCH CHECKS	
LOCATION	EACH
32+50	1

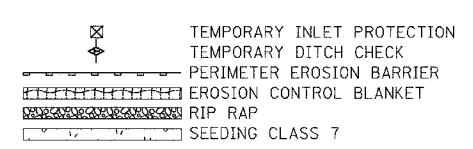

INTENDED SEQUENCE

- 1) PLACE PERIMETER EROSION CONTROL BARRIER PRIOR TO COMMENCEMENT OF ANY WORK. SEE STD. 280001
- 2) CONSTRUCT EARTHWORK, DITCHES FIRST. (MAXIMUM 10 ACRES DISTURBED AT ONE TIME PRIOR TO SEEDING. SEE ART. 202 & 280)
- 3) PLACE AND MAINTAIN TEMPORARY AND PERMANENT EROSION CONTROLS AS WORK PROGRESSES, SEED EVERY 7 DAYS. SEE ART. 280
- 4) FINAL SHAPE, GRADE, AND PAVE ROADWAY
- 5) PLACE REMAINING PERMANENT EROSION CONTROLS.

REVISIONS	
NAME	DATE

ILLINOIS DEPARTMENT OF TRANSPORTATION

EROSION CONTROL PLAN

SCALE: VERT. 1" = 50'
 HORIZ. 1" = 50'
 DATE 08/16/2005

DRAWN BY RLH
 CHECKED BY MED

TUG PROJ. #1391022-5
 SHEET EROSION-W.dgn
 08/16/2005

F.A.S. RTE.	SECTION	COUNTY	TOTAL SHEETS	SHEET NO.
642	99-00124-01-PV	COLES	157	73
STA.	TO STA.			
FED. ROAD DIST. NO.	ILLINOIS	FED. AID PROJECT		

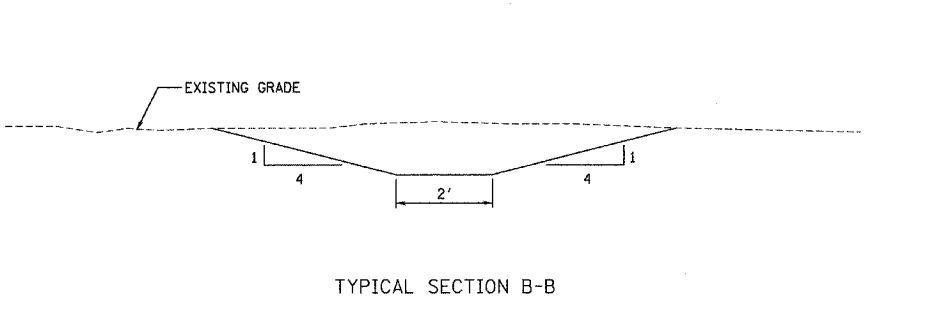
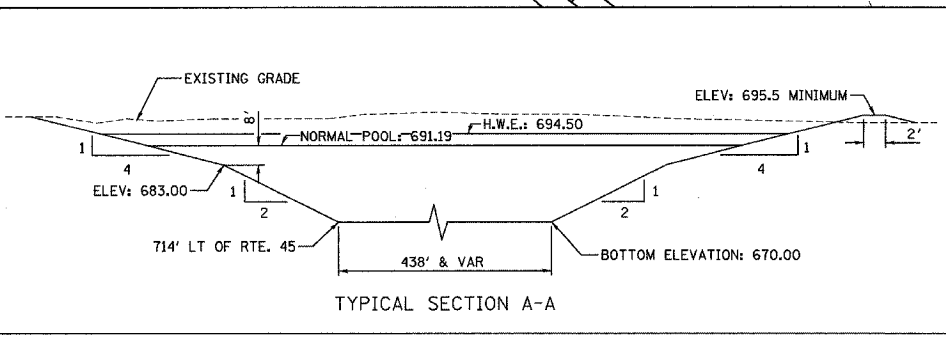
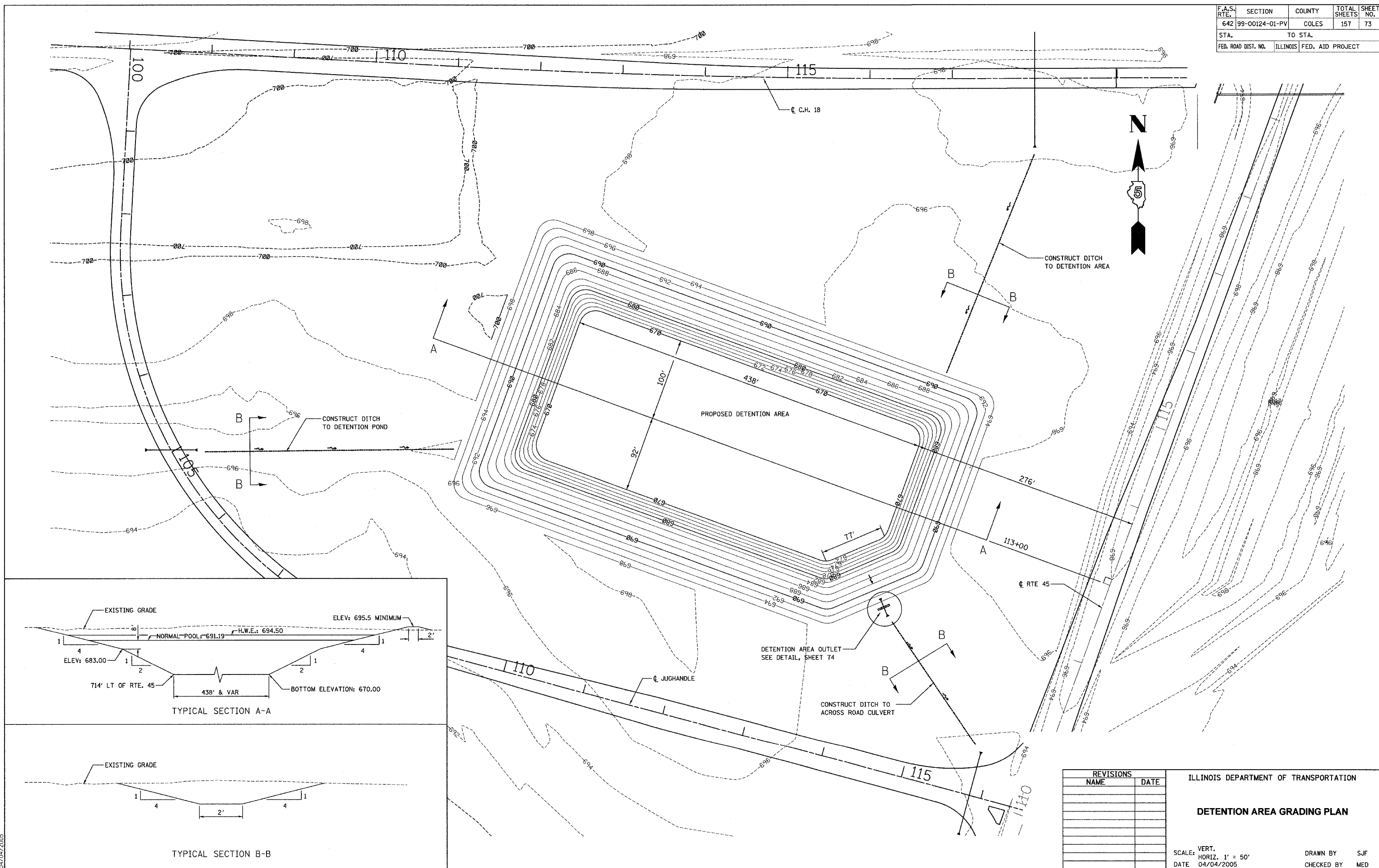

REVISIONS	
NAME	DATE

ILLINOIS DEPARTMENT OF TRANSPORTATION
DETENTION AREA GRADING PLAN

SCALE: VERT. 1" = 50'
 HORIZ. 1" = 50'
 DATE 04/04/2005
 DRAWN BY SJF
 CHECKED BY MED

T:\C PROJ #3187022-5
 \S\SHEET\DETENTION.dgn
 04/04/2005

F.A.S. RTE.	SECTION	COUNTY	TOTAL SHEETS	SHEET NO.
642	99-00124-01-PV	COLES	157	74
STA.		TO STA.		
FED. ROAD DIST. NO.		ILLINOIS FED. AID PROJECT		

DETAIL OF SPECIAL INLET FOR COMBINATION CONCRETE CURB AND GUTTER (BARRIER CURB)

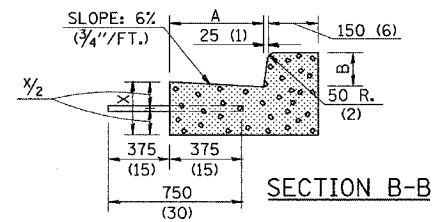
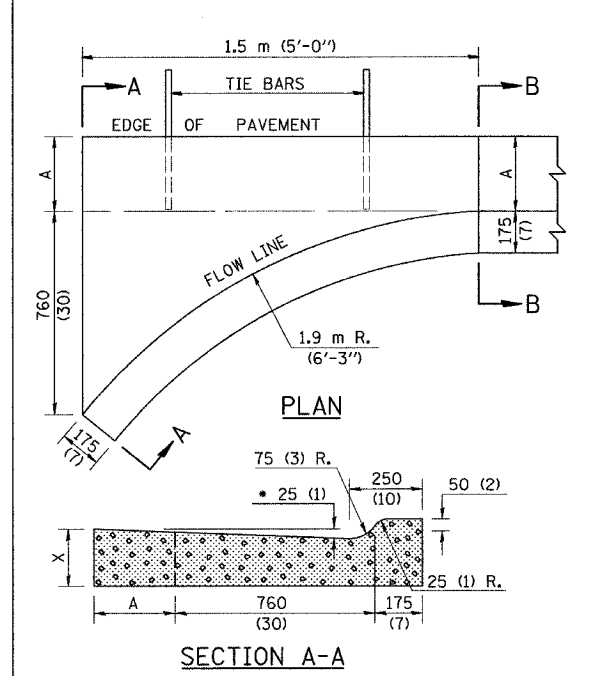

* NOTE: INCREASE TO 50 mm (2") WHERE IN THE PLANS IT IS SPECIFIED THAT THESE SPECIAL INLETS ARE TO BE CONSTRUCTED AS OUTLETS. ALL OUTLET LOCATIONS WILL BE CONFIRMED BY THE ENGINEER.

CONVERSION	B-15.30 (B-6.12)	B-22.30 (B-9.12)	B-15.45 (B-6.18)	B-22.45 (B-9.18)	B-15.60 (B-6.24)	B-22.60 (B-9.24)
A	300	300	300	300	450	450
B	150	150	225	225	150	150
X	225	250	225	250	225	250
m ²	0.28	0.32	0.29	0.32	0.34	0.37
(CU. YDS.)	(0.37)	(0.42)	(0.38)	(0.42)	(0.44)	(0.49)
CLASS SI CONCRETE (OUTLETS)	(0.45)	(0.50)	(0.51)	(0.56)	(0.52)	(0.57)

GENERAL NOTES

- CLASS SI CONCRETE SHALL BE USED THROUGHOUT.
 - TIE BARS SHALL BE NO. 20 (NO. 6) AT 600 mm (24") CENTERS UNLESS OTHERWISE SHOWN. SPECIAL INLETS AND OUTLETS SHALL BE TIED TO THE PAVEMENT IN ACCORDANCE WITH DETAILS FOR LONGITUDINAL CONSTRUCTION JOINT SHOWN ON STANDARD 420001.
 - TIE BARS SHOWN ABOVE WILL NOT BE PAID FOR SEPARATELY BUT SHALL BE CONSIDERED AS INCIDENTAL TO CLASS SI CONCRETE OUTLETS.
 - WHEN SPECIAL INLET IS CONSTRUCTED ADJACENT TO FLEXIBLE PAVEMENT, THE TIE BARS SHALL BE OMITTED AND ALL CONSTRUCTION JOINTS SHALL BE PROVIDED WITH A DOWEL BAR CONFORMING TO ARTICLE 1006.11(b) [(706.11(b))].
 - THIS WORK WILL BE PAID FOR AT THE CONTRACT UNIT PRICE PER m³ (CU. YD.) FOR CLASS SI CONCRETE (OUTLETS) WHICH PRICE SHALL INCLUDE ALL LABOR AND MATERIAL AS SPECIFIED AND NO ADDITIONAL COMPENSATION WILL BE ALLOWED.
- All dimensions are in millimeters (inches) unless otherwise shown.

DESIGNED	NAME	DATE	REVISIONS	NAME	DATE
J.H.M.	J.H.M.	6/88			
P.E.K.	P.E.K.	6/88		G.A.M. (metric)	10/95
A-2.01	A-2.01			D.L.P.	10/96

STATION	DEPTH	POOL LENGTH	APRON LENGTH	WIDTH OF POOL AT OUTLET	THICKNESS AT APRON	THICKNESS AT REST OF BASIN
WATERWAY	0.25	11	5	10.0	2.00	1.50

NOTE: WARP BASIN TO CONFORM TO NATURAL STREAM CHANNEL. TOP OF RIPRAP IN FLOOR OF BASIN SHOULD BE AT THE SAME ELEVATION OR LOWER THAN NATURAL CHANNEL BOTTOM AT END OF APRON.

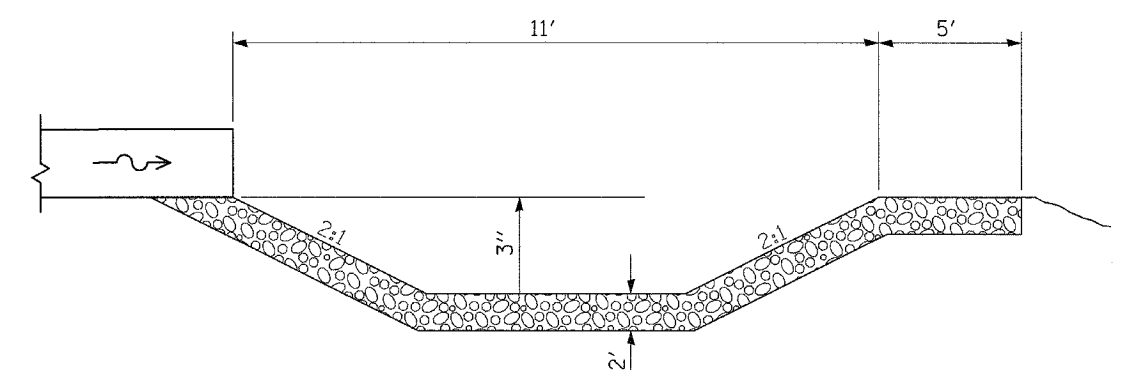

RIPRAP STILLING BASIN DETAIL

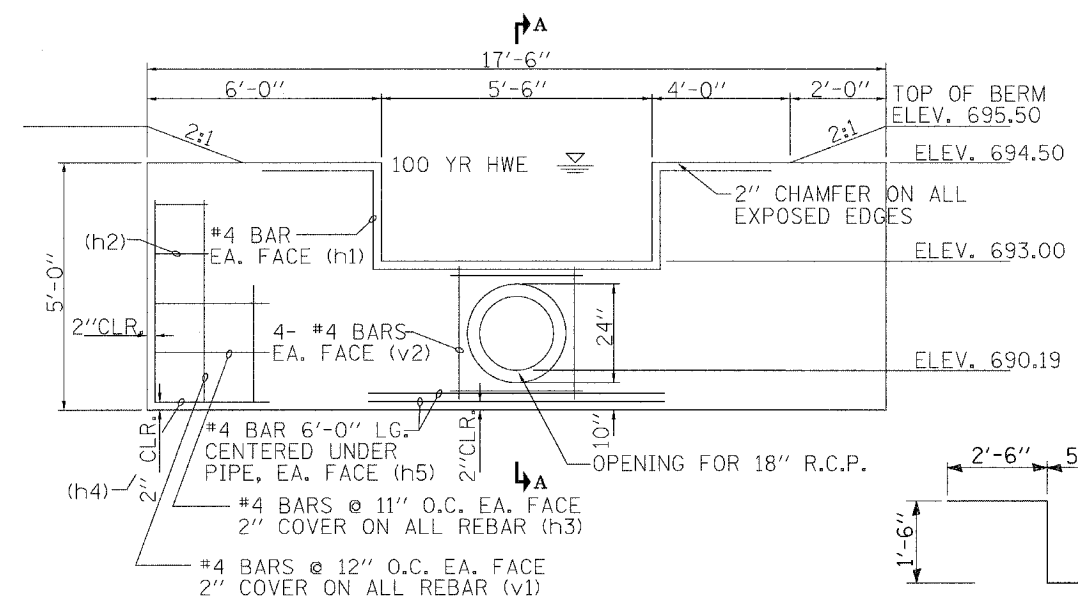

BAR SIZE	NUMBER	LENGTH	SHAPE
h1 #4	2	13'-10"	┌
h2 #4	8	5'-8"	—
h3 #4	8	7'-5"	—
h4 #4	4	17'-2"	—
h5 #4	2	6'-10"	—
v1 #4	24	4'-8"	—
v2 #4	12	3'-2"	—

BAR h1

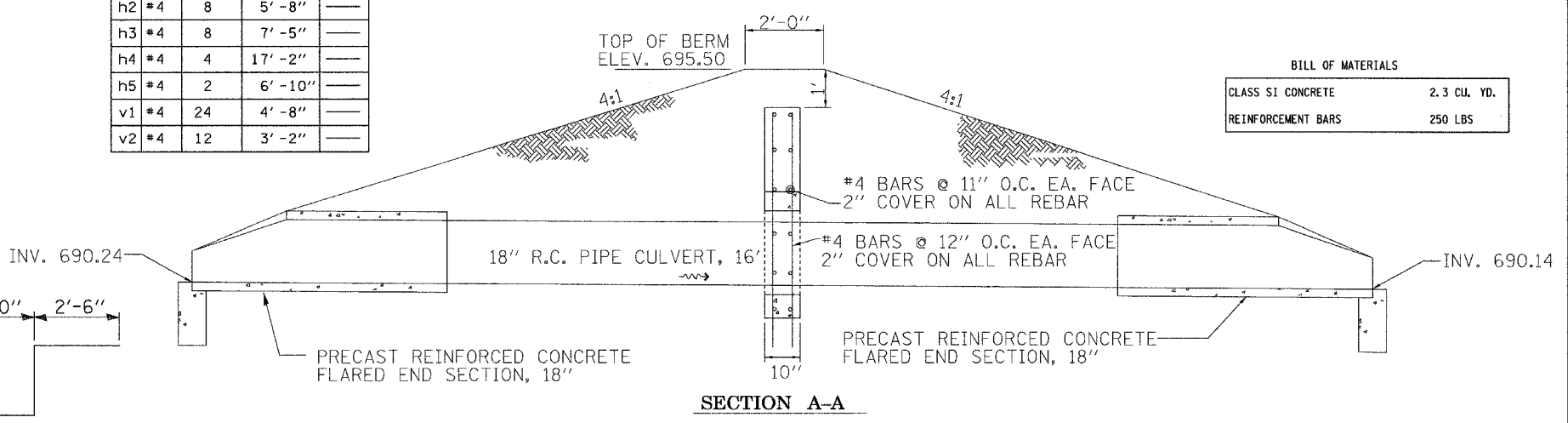

SECTION A-A

BILL OF MATERIALS	
CLASS SI CONCRETE	2.3 CU. YD.
REINFORCEMENT BARS	250 LBS

ELEVATION OF WEIR
LOOKING SOUTH EAST

DETENTION AREA OUTLET DETAIL US RTE 45, STA. 111+82 LT

REVISIONS	
NAME	DATE

ILLINOIS DEPARTMENT OF TRANSPORTATION
DETAILS
SCALE: VERT. _____
HORIZ. _____
DATE 04/04/2005
DRAWN BY RLH
CHECKED BY MED

TUG PROJ. #13197022-5
SHEET DETAILS-W.dgn
04/04/2005

F.A.S. RTE.	SECTION	COUNTY	TOTAL SHEETS	SHEET NO.
642	99-00124-01-PV	COLES	157	75
STA.		TO STA.		
FED. ROAD DIST. NO.		ILLINOIS	FED. AID PROJECT	

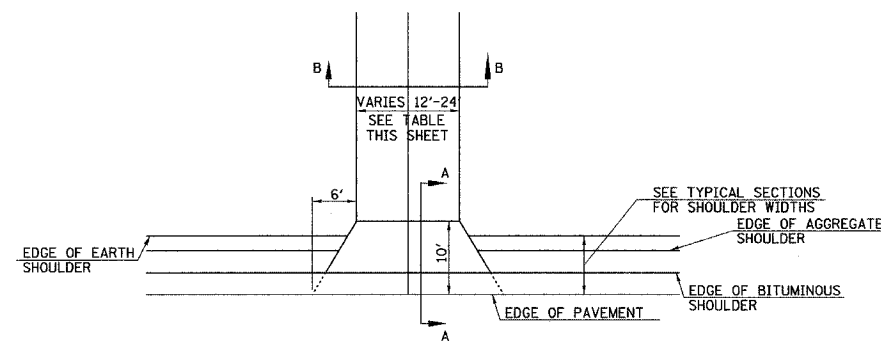

TYPICAL PRIVATE ENTRANCE DETAIL

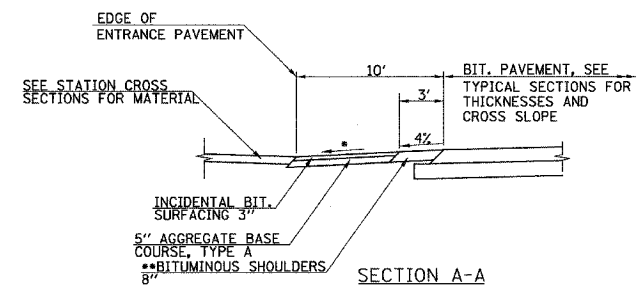

• 4% UNLESS OTHERWISE NOTED ON STATION CROSS SECTIONS

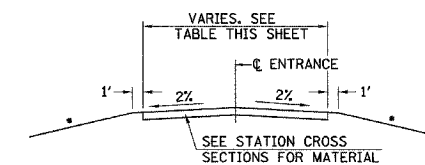

SECTION B-B

• 4:1 MIN. SLOPE TO MATCH EXISTING GROUND

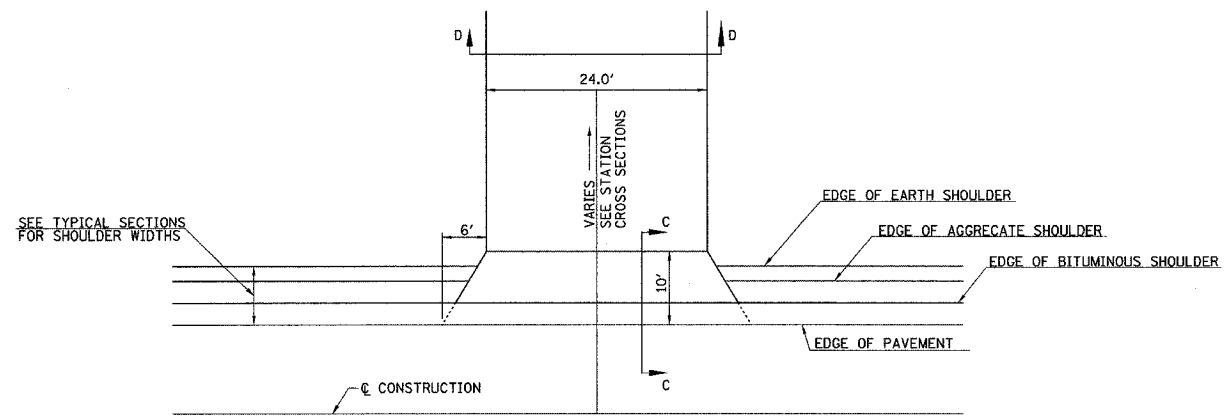

TYPICAL FIELD ENTRANCE DETAIL

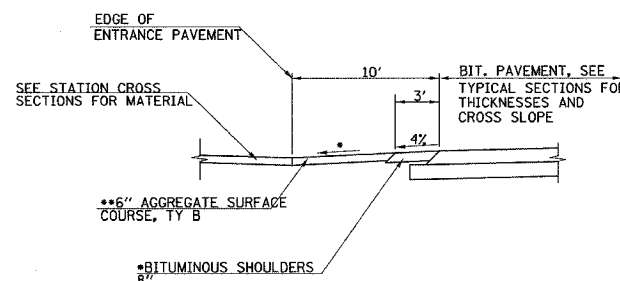

• 4% UNLESS OTHERWISE NOTED ON STATION CROSS SECTIONS
 • F.E. @ STA. 142+14.11 LT USE 12" AGGREGATE SURFACE COURSE, TY B

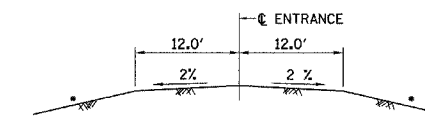

SECTION D-D

• 4:1 MIN. SLOPE TO MATCH EXISTING GROUND

LOCATION	WIDTH	DESCRIPTION	LENGTH (FROM EDGE OF PVT TO LIMITS OF IMPROVEMENT)	AGG. BASE COURSE TY. A	AGG. SURF. COURSE TY. B	INCIDENTAL BITUMINOUS SURF.	BITUMINOUS PRIME COAT	PCC DRIVEWAY PAVEMENT 8"
C. H. 18	FOOT		FOOT	TONS	TONS	TONS	GALLONS	SQ YD
102+81.33 LT	24	F. E.	46.2		7.5			
103+01.46 RT	24	F. E.	34.9		7.5			
107+02.88 LT	24	F. E.	42.1		7.5			
108+01.35 LT	18	P. E.	105.3	124.4		73.4	43.6	
136+73.27 LT		C. E.				70.6	84.1	4509.4
142+14.11 LT		F. E.	66.7		118.5			
144+30.93 RT	24	F. E.	43.8		7.5			
149+48.18 RT	35	C. E.	48.0					322.2
150+62.86 LT	24	F. E.	48.0		7.5			
152+63.93 RT	35	C. E.	48.0					321.1
154+26.74 LT	12	P. E.	48.0	6.7	17.3	4.0	2.4	
154+32.48 RT	35	C. E.	48.0					374.4
156+69.83 LT	24	F. E.	48.0		7.5			
160+95.89 LT	12	P. E.	48.0	6.7	17.3	4.0	2.4	
163+00.00 LT	24	F. E.	45.1		7.5			
163+00.00 RT	24	F. E.	46.9		7.5			
JUGHANDLE								
106+00.00 LT	24	F. E.	27.4		7.5			
TOTALS				137.8	220.6	152.0	132.5	5527.1

REVISIONS		ILLINOIS DEPARTMENT OF TRANSPORTATION
NAME	DATE	
		ENTRANCE DETAILS SCALE: VERT. _____ HORIZ. _____ DATE 04/04/2005

TUC PROJ. #181022-5
 TUC SHEET #ALS-WG01
 04/04/2005

F.A.S. RTE.	SECTION	COUNTY	TOTAL SHEETS	SHEET NO.
642	99-00124-01-PV	COLES	157	76
STA.		TO STA.		
FED. ROAD DIST. NO.		ILLINOIS		FED. AID PROJECT

DETAIL FOR TREATMENT OF EXISTING FIELD TILE SYSTEMS

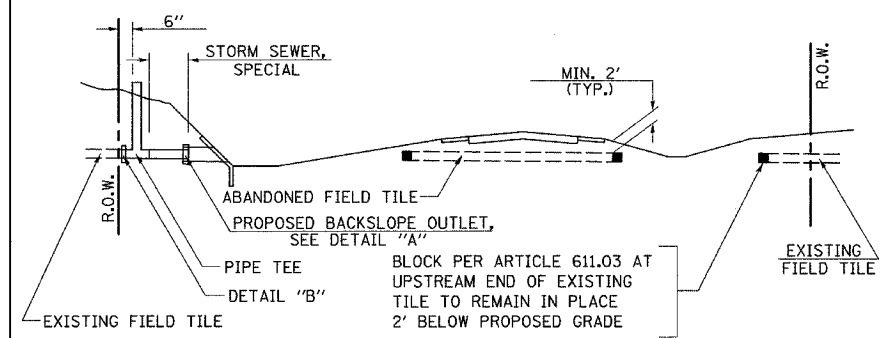

METHOD 'A' (2 LANE)

STORM SEWER FLOW LINE ABOVE PROPOSED DITCH FLOW LINE

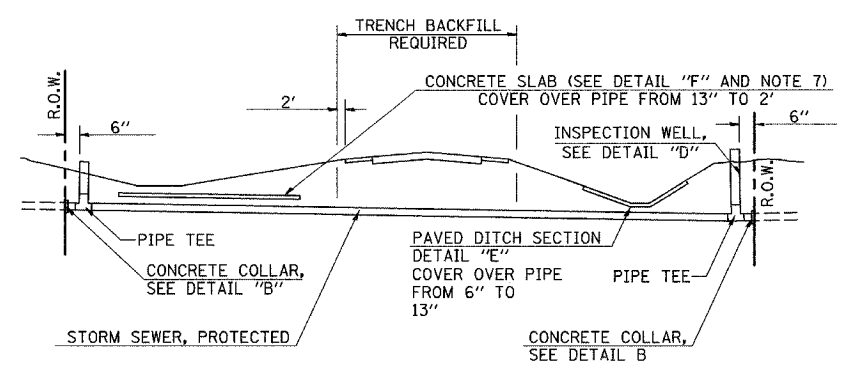

METHOD 'B' (2 LANE)

STORM SEWER LESS THAN 2' BELOW DITCH FLOW LINE AND STORM SEWERS CROSSING UNDER PAVEMENT AND PAVED DITCH

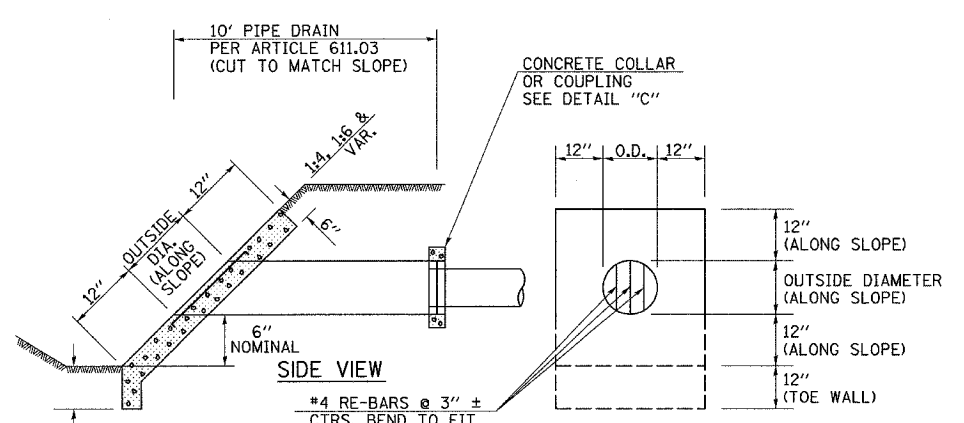

DETAIL OF RE-BARS HEADWALL FOR BACKSLOPE OUTLET - DETAIL "A"

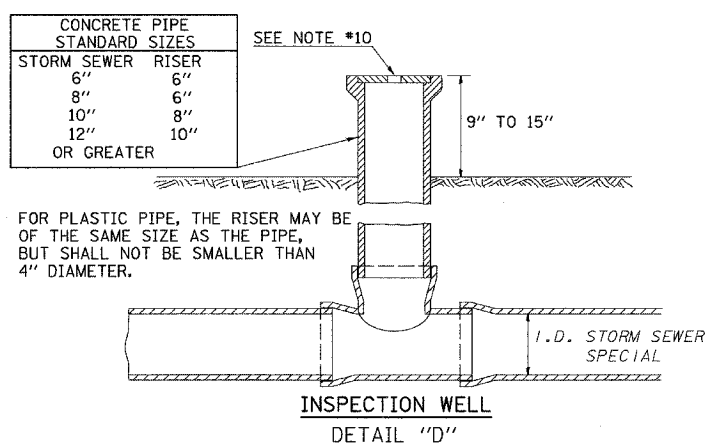

INSPECTION WELL DETAIL "D"

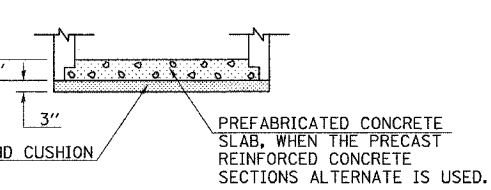
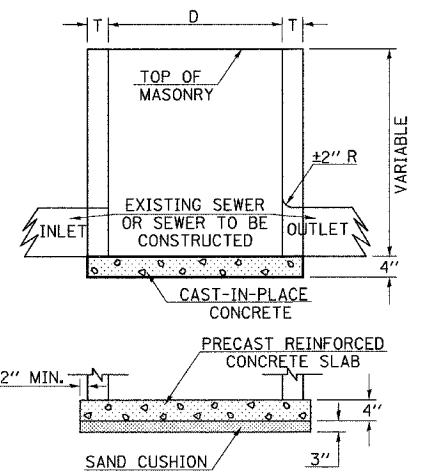

ALTERNATE BOTTOM SLAB

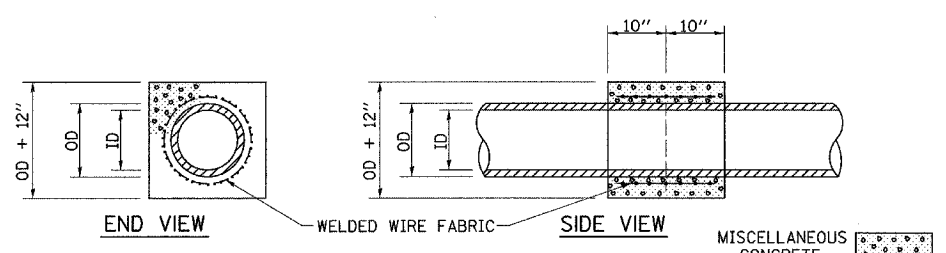

CONCRETE COLLAR DETAIL "B"

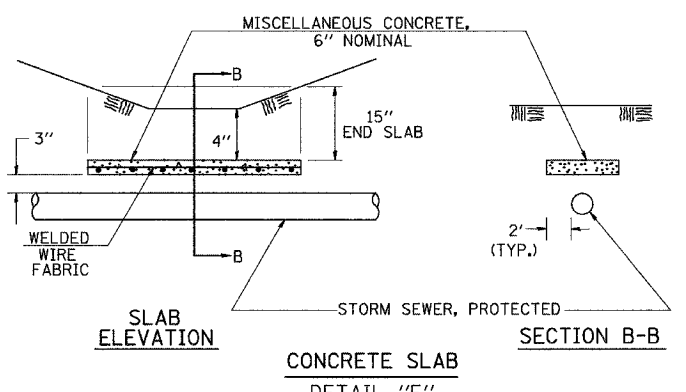

CONCRETE SLAB DETAIL "F"

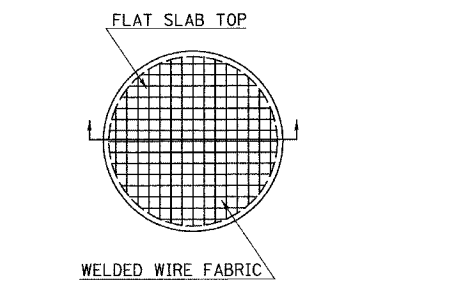

FIELD TILE JUNCTION VAULT DETAIL

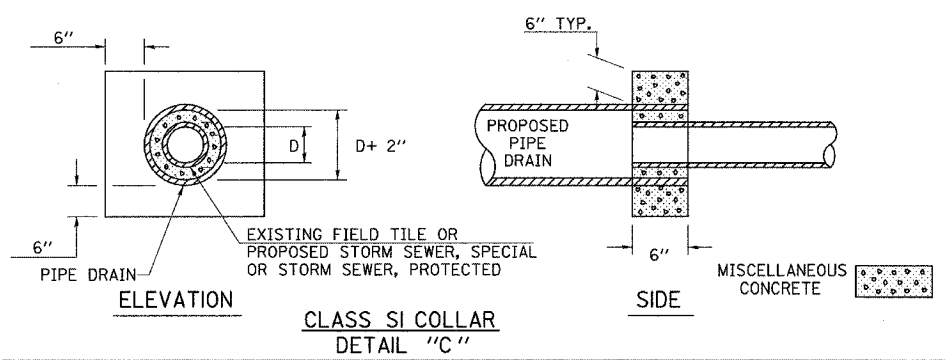

CLASS SI COLLAR DETAIL "C"

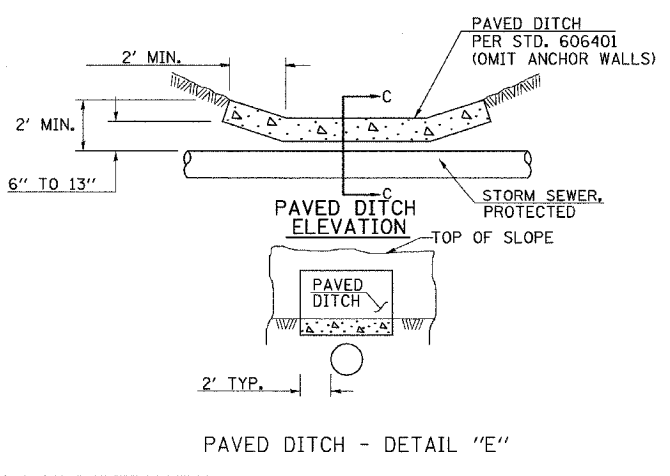

PAVED DITCH - DETAIL "E"

- GENERAL NOTES :**
- LOCATION OF THE EXPLORATION TRENCH 52" DEPTH SHALL BE INSIDE THE PROPOSED NORTH OR WEST RIGHT OF WAY LINE EXCEPT WHEN AN EXISTING RIGHT OF WAY LINE IS FURTHER NORTH OR WEST. IN WHICH CASE, THE EXPLORATION TRENCH SHALL BE INSIDE THE EXISTING NORTH OR WEST RIGHT OF WAY LINE, OR AS DIRECTED BY THE ENGINEER.
 - EXISTING FIELD TILE ENCOUNTERED BY EXPLORATION TRENCH SHALL BE INSPECTED BY THE ENGINEER FOR UNOBSTRUCTED FLOW WITHIN THE LIMITS OF THE RIGHT-OF-WAY.
 - ALL FIELD TILE THAT CROSSES THE PROPOSED ROADWAY SHALL BE REPLACED WITHIN THE LIMITS OF THE RIGHT-OF-WAY IN ACCORDANCE WITH METHOD "B" AND AT THE DIRECTION OF THE ENGINEER.
 - INSPECTION WELLS SHALL BE CONSTRUCTED APPROXIMATELY 6" INSIDE OF BOTH RIGHT-OF-WAY LINES AT ALL FIELD TILE LOCATIONS.
 - EXISTING FIELD TILE ABANDONED UNDER EXISTING PAVEMENTS OR PAVED SHOULDERS SHALL BE FILLED WITH FLOWABLE GROUT AS DIRECTED BY THE ENGINEER. THIS WORK WILL BE PAID FOR ACCORDING TO ARTICLE 109.04.
 - NON-CIRCULAR FIELD TILE SHALL BE REPLACED WITH STORM SEWER, SPECIAL OF AT LEAST THE SAME CROSS SECTIONAL AREA. ALL EXISTING FIELD TILE SHALL BE REPLACED WITH STORM SEWER OF THE TYPE REQUIRED FOR THE MINIMUM DEPTH OF COVER.
 - THE 6" CONCRETE SLAB OR DITCH LINING SHALL BE POURED THE LENGTH OF THE TRENCH AT ALL DITCH FLOW LINE LOCATIONS WITHIN THE RIGHT OF WAY WITH LESS THAN 2' OF EARTH COVER. MISCELLANEOUS CONCRETE SHALL BE USED ACCORDING TO SECTION 611.
 - ALL MISCELLANEOUS SLABS, APRONS, AND DITCH LININGS SHALL BE REINFORCED WITH WELDED WIRE FABRIC AS SHOWN FOR PAVED DITCH IN STANDARD 606401. THE WELDED WIRE FABRIC SHALL BE INCLUDED IN THE COST FOR PAVED DITCH OR MISCELLANEOUS CONCRETE.
 - HEADWALL FOR BACKSLOPE OUTLET MAY BE USED FOR PIPE DRAIN DIAMETERS UP TO 10". SPECIAL DESIGNS WILL BE REQUIRED FOR LARGER SIZES.
 - THE INSPECTION WELL LID FOR P.C.C. PIPE SHALL BE CONSTRUCTED OF 3/8" CAST IRON PROVIDED WITH A 1" DIAMETER HOLE IN CENTER. THE LID FOR THE OTHER PIPE MATERIALS SHALL BE A GRATE ASSEMBLY PREFABRICATED FOR AND COMPATIBLE WITH THE PIPE SYSTEM.
 - SEE SECTION 611 OF THE STANDARD SPECIFICATIONS FOR WHEN TO USE FIELD TILE JUNCTION VAULTS. FIELD TILE JUNCTION VAULTS SHALL BE CONSTRUCTED ACCORDING TO THE DETAILS SHOWN ON THIS SHEET AND THE APPLICABLE PORTIONS OF SECTION 602. THE DEPTH OF THE JUNCTION VAULT SHALL BE VERIFIED IN THE FIELD BY THE ENGINEER. STORM SEWER SPECIAL PIPE SHOULD BE LAID ON A MINIMUM GRADE OF 1%. EXCAVATION, BEDDING AND BACKFILL SHALL BE INCLUDED IN THE CONTRACT UNIT PRICE PER EACH FOR FIELD TILE JUNCTION VAULTS, 2' DIA.

D	Do (MIN.)	REINFORCEMENT "AS" W.W.F. EACH DIRECTION
2'	D+2"	.20 IN. 2/FT.
3'	D+2"	.20 IN. 2/FT.

ALTERNATE MATERIALS FOR WALLS	T (MIN.)
PRECAST REINFORCED CONCRETE SECTION	3"
CONCRETE MASONRY UNIT	5"
CAST IN PLACE CONCRETE	6"
BRICK MASONRY	8"

REVISIONS	
NAME	DATE

ILLINOIS DEPARTMENT OF TRANSPORTATION

FIELD TILE TREATMENT DETAIL

SCALE: VERT. HORIZ. DATE 04/04/2005

DRAWN BY SJF CHECKED BY MED

LAYOUT SKM 12/26/03
 DRAWN DAP 12/26/03
 REVIEWED SKM 01/05/04

TUG PROJ. #191702-5
 \N\SHEETDETAILS\W.dgn
 04/04/2005

F.A.S. RTE.	SECTION	COUNTY	TOTAL SHEETS	SHEET NO.
642	99-00124-01-PV	COLES	157	77
STA.		TO STA.		
FED. ROAD DIST. NO.	ILLINOIS	FED. AID PROJECT		

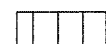
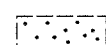
-  BITUMINOUS SURFACE REMOVAL
-  PROPOSED OVERLAY
-  EXISTING BITUMINOUS CONCRETE PAVEMENT OR OVERLAY

BUTT JOINT DETAIL (1 1/2" SURFACE REMOVAL)

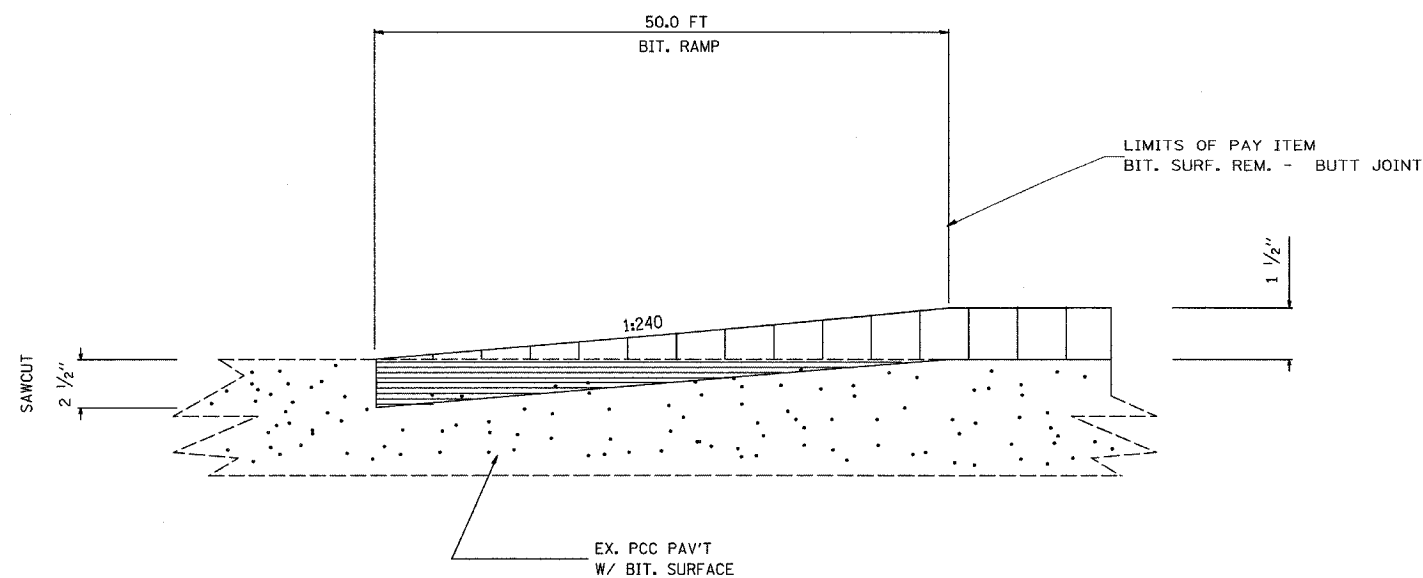

LOCATION (STATION TO STATION)	ROUTE	BITUMINOUS SURFACE REMOVAL - BUTT JOINT	TEMPORARY RAMP
		QUANTITY (SQ YD)	QUANTITY (SQ YD)
STA 101+14 TO STA 101+34	US 45	80	13.3
STA 126+95 TO STA 127+25	US 45	80	13.3
STA 116+26 TO STA 116+47	JUGHANDLE	0	85.0
TOTAL		160	111.6

LOCATION & DESIGN OF
BLOCKOUTS FOR SIGN POSTS

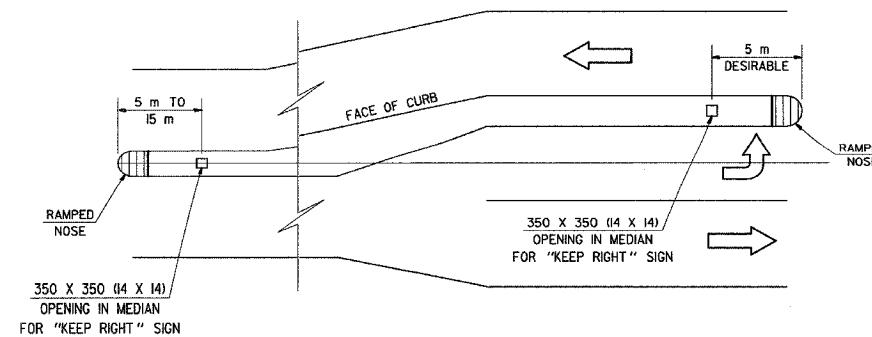

LOCATION OF OPENINGS FOR "KEEP RIGHT" SIGNS

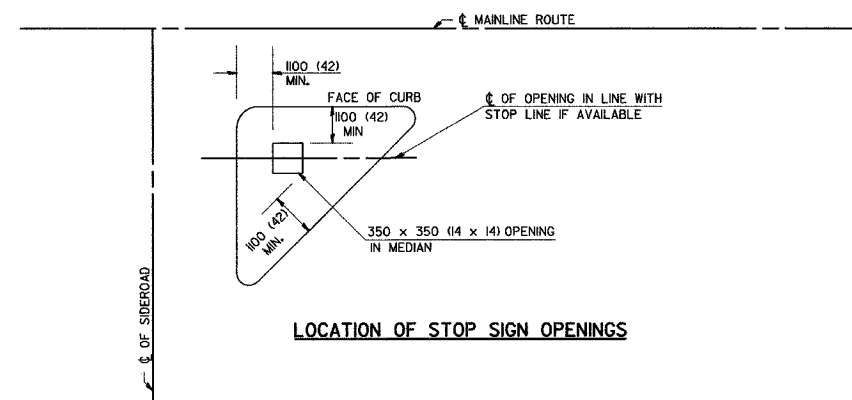

LOCATION OF STOP SIGN OPENINGS

GENERAL NOTES

- 1.) ALL SMALL ISLANDS SHALL BE CONSTRUCTED WITH THE STOP SIGN ISLANDS AS SHOWN, UNLESS OTHERWISE SPECIFIED.
- 2.) OPENINGS FOR SIGNS IN MEDIANS SHALL BE AS SHOWN OR AS DIRECTED BY THE ENGINEER.
- 3.) THIS WORK WILL NOT BE PAID FOR SEPARATELY, BUT SHALL BE INCLUDED IN THE CONTRACT UNIT PRICE FOR THE TYPE OF MEDIAN SPECIFIED IN THE PLANS AND NO ADDITIONAL COMPENSATION WILL BE ALLOWED.
- 4.) ALL DIMENSIONS ARE IN MILLIMETERS (INCHES) UNLESS OTHERWISE NOTED.

DESIGNED	NAME	DATE	REVISIONS	
J.M.H.		8-25-87	NAME	DATE
CHECKED	P.E.K.	8-25-87	D.L.P.	7/96
CADD NO.	A-5.03		D.L.P.	7/98

REVISIONS		ILLINOIS DEPARTMENT OF TRANSPORTATION
NAME	DATE	
		DETAILS

SCALE: VERT. _____
HORIZ. _____
DATE 04/04/2005

DRAWN BY _____
CHECKED BY MED

T:\C PROJ. #91292-5
SHEET TAIL S-W.dgn
04/04/2005

F.A.S. RTE.	SECTION	COUNTY	TOTAL SHEETS	SHEET NO.
642	99-00124-01-PV	COLES	157	78
STA.		TO STA.		
FED. ROAD DIST. NO.	ILLINOIS	FED. AID PROJECT		

DETAIL OF SURVEY MARKER VAULT

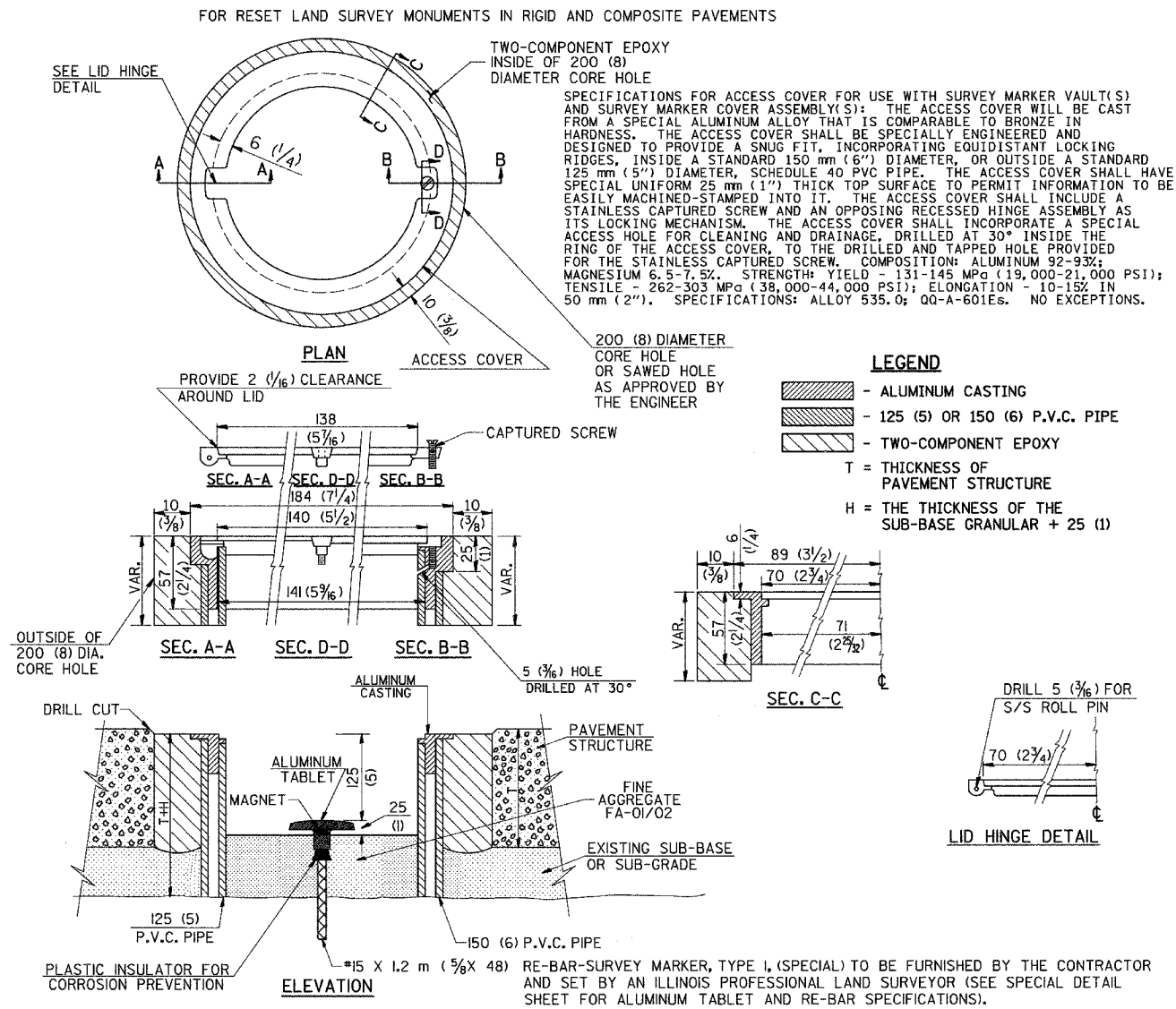

GENERAL NOTES

- ALUMINUM CASTING SHALL BE EITHER PLACED OVER A 125 mm (5") P.V.C. PIPE OR INSIDE OF A 150 mm (6") P.V.C. PIPE.
- BACKFILL WITH FINE AGGREGATE-FA-01/02,
- WORK SHALL NOT START ON THIS ITEM UNTIL THE FINAL LIFT OF CLASS I HAS BEEN COMPLETED.
- THIS WORK WILL BE PAID FOR AT THE CONTRACT UNIT PRICE EACH FOR SURVEY MARKER VAULT WHICH PRICE SHALL INCLUDE ALL LABOR AND MATERIAL AS SPECIFIED INCLUDING CORING, EPOXY AND FA-01/02 AGGREGATE AND NO ADDITIONAL COMPENSATION WILL BE ALLOWED.
- THE CASTING SHALL BE ANCHORED IN THE 200 mm (8") DIAMETER CORE HOLE WITH TWO-COMPONENT EPOXY CONFORMING TO APPLICABLE PORTIONS OF ARTICLE 1025.01 (725.01) OF THE STANDARD SPECIFICATIONS.
- ALL SURVEY MARKER (VAULTS) SHALL BE PLACED 6 mm (1/4") ± BELOW THE FINAL SURFACE.
- THE 200 mm (8") DIAMETER CORE HOLE SHALL BE SUBJECT TO THE APPROVAL OF THE ENGINEER.

All dimensions are in millimeters (Inches) unless otherwise shown.

REVISIONS		ILLINOIS DEPARTMENT OF TRANSPORTATION
NAME	DATE	
		SURVEY MARKER VAULT DETAIL

SCALE: VERT. _____
 HORIZ. _____
 DATE 04/04/2005

DRAWN BY _____
 CHECKED BY MED

TUC PROJ #107022-5
 SHEET DETAIL S-W-697
 04/04/2005

F.A.S. RTE.	SECTION	COUNTY	TOTAL SHEETS	SHEET NO.
642	99-00124-01-PV	COLES	157	79
STA.		TO STA.		
FED. ROAD DIST. NO.	ILLINOIS	FED. AID PROJECT		

SURVEY MARKER, TYPE 1 (SPECIAL)

TO BE USED IN FLEXIBLE PAVEMENT AND SHOULDER, A-3 BITUMINOUS TREATED SURFACE OVER AGGREGATE BASE COURSE AND TURF AREAS WITHIN THE RIGHT-OF-WAY LIMITS FOR RESETTING EXISTING CENTERLINE CONTROL POINTS AND LAND SURVEY MONUMENTS

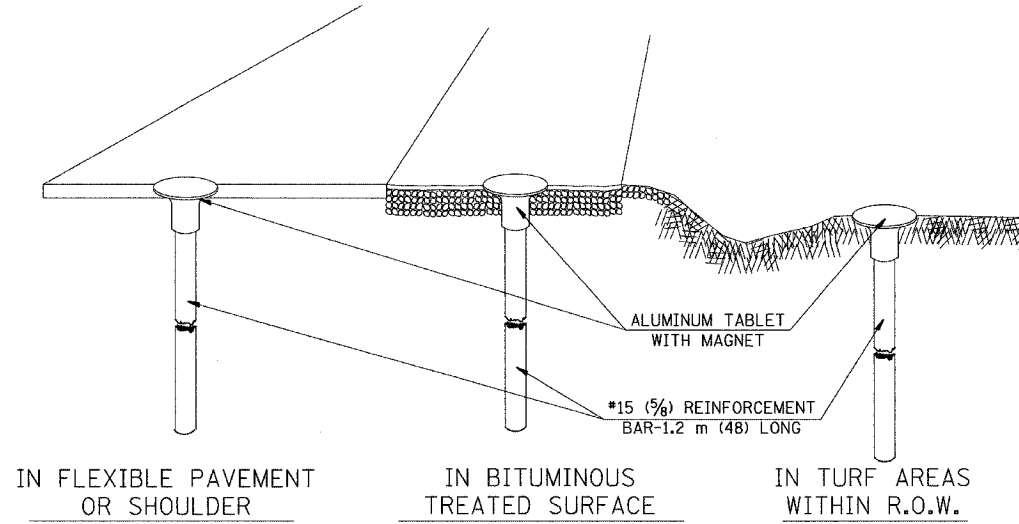

GENERAL NOTES

1. WORK ON THIS ITEM SHALL NOT START UNTIL THE FINAL SURFACE IS COMPLETED.
2. THE ALUMINUM TABLET (FORKED) SHALL REST UPON THE BOTTOM OF THE 100 mm (4") CORE HOLE. IF THE HOLE IS TOO DEEP, EPOXY GROUT MUST BE USED TO DECREASE THE DEPTH AND ALLOWED TO HARDEN BEFORE PROCEEDING.
3. THE ALUMINUM TABLET SHALL BE ANCHORED IN THE 100 mm (4") DIAMETER HOLE IN THE NEW PAVEMENT WITH TWO-COMPONENT EPOXY GROUT CONFORMING TO APPLICABLE PORTIONS OF ARTICLE 1025.01 (725.01) OF THE STANDARD SPECIFICATIONS.
4. THE 100 mm (4") CORE HOLE SHALL BE SUBJECT TO THE APPROVAL OF THE ENGINEER.
5. THE CONTRACT PRICE, EACH, FOR SURVEY MARKER, TYPE 2 (SPECIAL) SHALL BE PAYMENT IN FULL FOR FURNISHING THE ALUMINUM TABLET AND ALL LABOR AND MATERIAL TO SET THE MARKER IN PLACE, AS SPECIFIED, INCLUDING CORING THE NEW PAVEMENT.
6. ALL SURVEY MARKERS, TYPE 2 (SPECIAL) SHALL BE PLACED ± 6 mm (1/4") BELOW THE FINAL SURFACE.

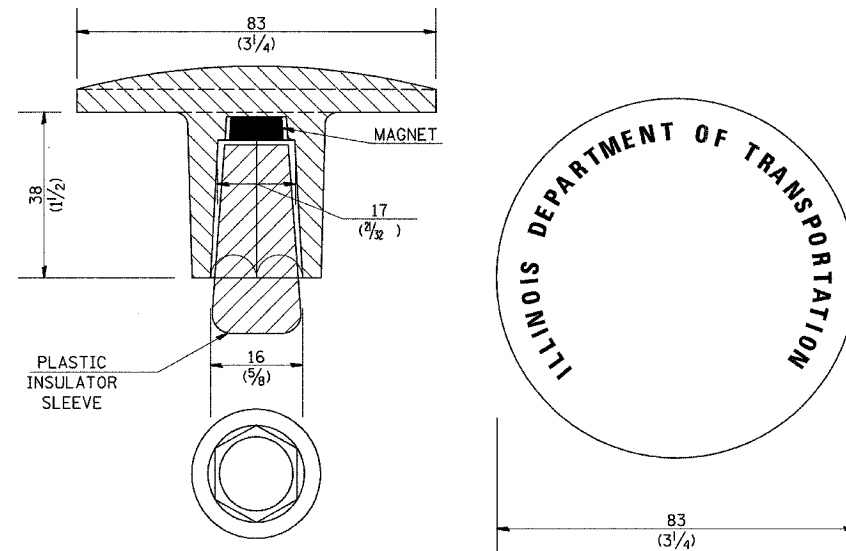

SPECIFICATIONS FOR ALUMINUM TABLET

SURVEY CAP FOR REBAR. 83 mm (3 1/4") CONVEX SURVEY CAP FOR 15 mm (5/8") REBAR WITH ILLINOIS DEPARTMENT OF TRANSPORTATION LOGO. THIS LOGO SHALL PROVIDE LETTERS RECESSED INTO THE SURFACE A MINIMUM OF 0.8 mm (1/32") FOR EASY AND LONG-TERM LEGIBILITY. THE ALUMINUM CAP FOR REBAR SHALL BE PRODUCED BY THE PROCESS OF ORBITAL FORGING TO PRODUCE A HIGH-STRENGTH AND DURABLE MARKER CAP WHICH WILL NOT CHIP OR BREAK AND PROVIDE A SMOOTH FINISH FOR STAMPING OF DATA IN THE FIELD. THE ALUMINUM CAP FOR REBAR SHALL BE TAPERED FOR A PERFECT COMPRESSION FIT. A SPECIAL PLASTIC INSULATOR SHALL BE INSTALLED TO PREVENT DISSIMILAR METAL CONTACT AND CORROSION. THE PLASTIC INSULATOR SHALL FORM READILY TO THE OUTER SHAPE OF THE REBAR AND TO THE INNER SHAPE OF THE ALUMINUM CAP SOCKET. THE PLASTIC INSULATOR SHALL BE LOW DENSITY POLYETHYLENE, A MINIMUM 38 mm (1 1/2") LONG AND CONFORM TO FEDERAL SPECIFICATION L-P 390.

COMPOSITION: ALUMINUM 98.3-98.7%; OTHER 1.3-1.7%; STRENGTH: YIELD 193 MPa (28 KSI), ULTIMATE 221 MPa (32 KSI). ELONGATION 15% [IN 50 mm (2")]. SPECIFICATIONS: ALUMINUM ALLOY 6101-0; ASTM B317-83 (EXCEPT TEMPER) AS FORGED. NO EXCEPTIONS.

SPECIFICATION FOR REBAR

REBAR FOR ALUMINUM TABLET. REINFORCEMENT BAR SHALL BE #15 (5/8") X 1.2 m (48") (DEFORMED).

INSPECTION OF REINFORCEMENT BAR #15 (5/8") SHALL BE DONE BY DISTRICT PERSONNEL OF THE ILLINOIS DEPARTMENT OF HIGHWAYS, DIVISION OF HIGHWAYS.

DIMENSIONS SHOWN SHALL BE EXACT, OTHERS MAY VARY, BUT SHALL BE SHOWN ON SHOP DRAWINGS.

GENERAL NOTES

1. THE CONTRACT UNIT PRICE, EACH, FOR SURVEY MARKER, TYPE 1, (SPECIAL) SHALL BE PAYMENT IN FULL FOR FURNISHING THE SURVEY MARKER.
2. ALL SURVEY MARKERS, TYPE 1 (SPECIAL) SHALL BE PLACED ± 6 mm (1/4") BELOW THE FINAL SURFACE.
3. WHEN THE TABLET AND REBAR ARE PLACED AS PART OF A SURVEY MARKER VAULT, THEY SHALL BE CONSIDERED AS INCLUDED IN THAT PAY ITEM AND THERE WILL BE NO PAYMENT FOR THE SURVEY MARKER, TYPE 1 (SPECIAL).

NAME		DATE	REVISIONS	
DESIGNED	AWH	8/17/91	NAME	DATE
CHECKED	PEK	8/17/91	G.A.M.	11-95
CADD NO.	D-1.05		D.L.P.	10-96

All dimensions are in millimeters (inches) unless otherwise shown.

REVISIONS		ILLINOIS DEPARTMENT OF TRANSPORTATION
NAME	DATE	
		SURVEY MARKER DETAIL
SCALE: VERT. DRAWN BY		DATE: 04/04/2005 CHECKED BY: MED
HORIZ. DATE: 04/04/2005		

TUC PROJ #197022-E
 \SHEETDETAILS\W.dgn
 04/04/2005

F.A.S. RTE.	SECTION	COUNTY	TOTAL SHEETS	SHEET NO.
642	99-00124-01-PV	COLES	157	80
STA.		TO STA.		
FED. ROAD DIST. NO.		ILLINOIS FED. AID PROJECT		

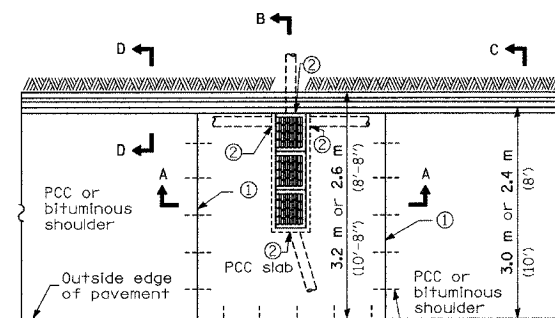

① Joints in prolongation with existing joints in pavements.
 ② See plans for locations for pipe block-outs.

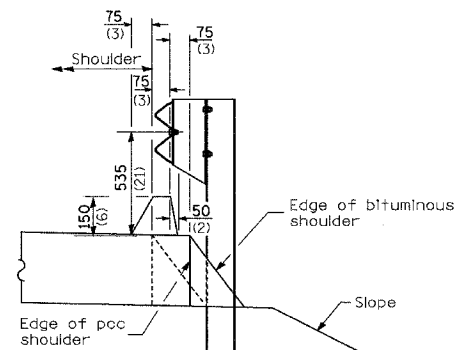

DETAIL B

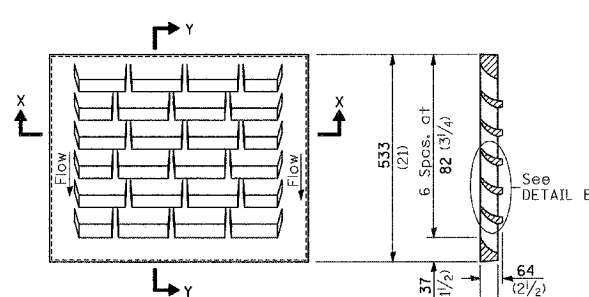

DETAIL OF CAST GRATE
 Type E requires 2 grates
 Type F requires 3 grates

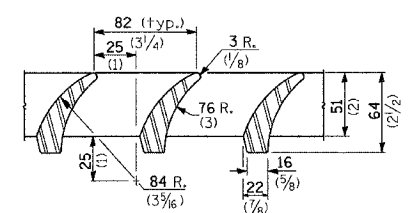

DETAIL B

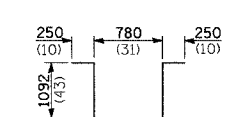

BAR U

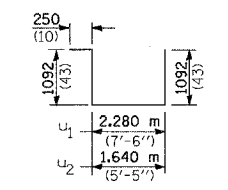

BARS U₁, U₂

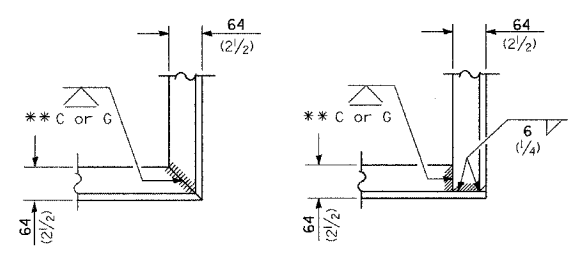

ALTS. 1 ALTS. 2
TYPICAL CORNER OF STEEL GRATING FRAME
 ** Cut or Grind flush

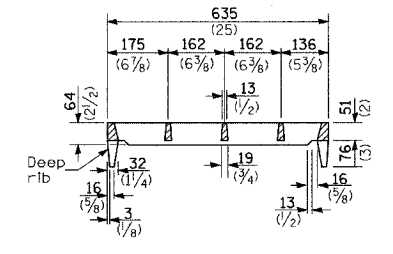

SECTION X-X
 (Deep rib shall be omitted for ends resting on frame perimeter)

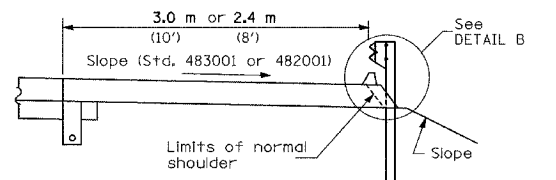

SECTION C-C

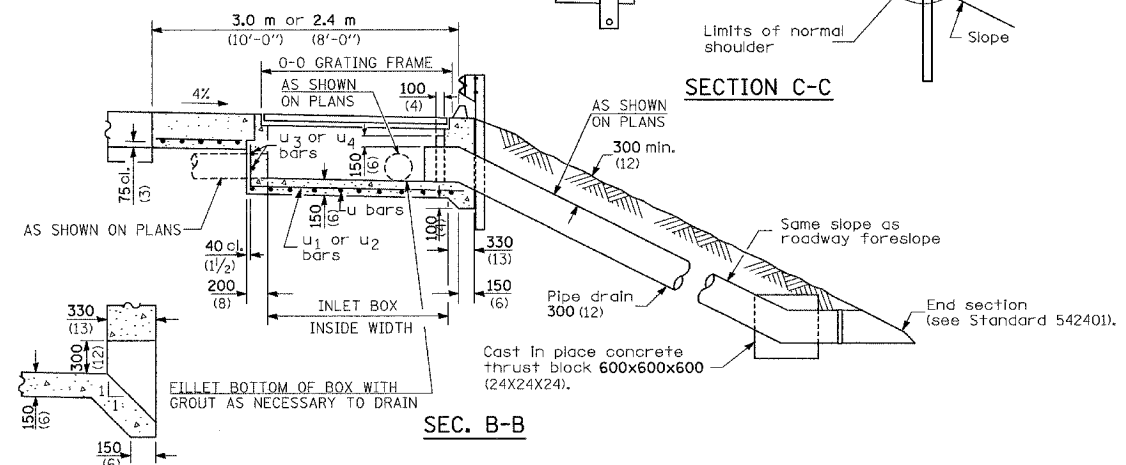

SEC. B-B

BOX OUTLET WHEN PRECAST

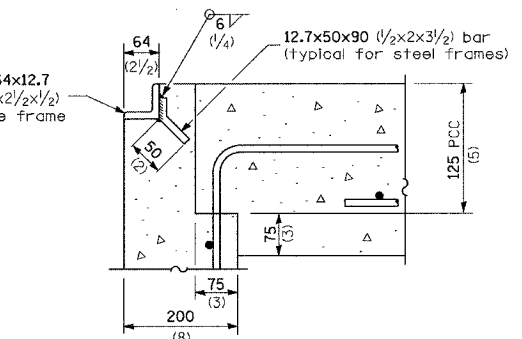

DETAIL A

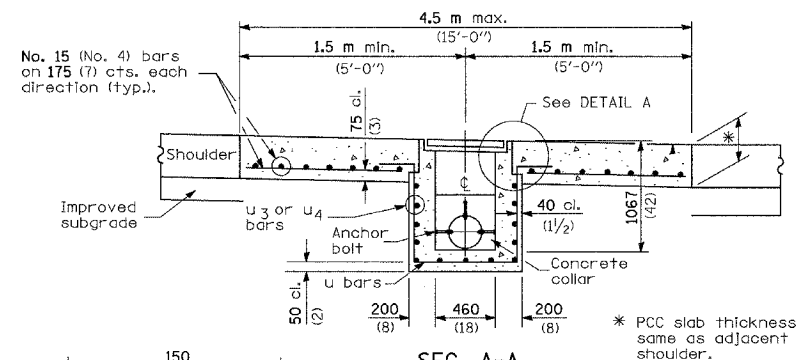

SEC. A-A

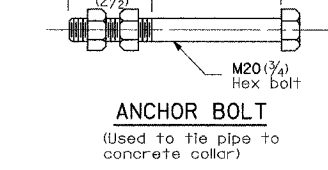

ANCHOR BOLT
 (Used to tie pipe to concrete collar)

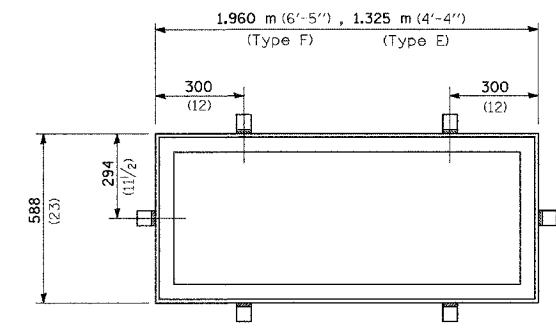

DETAIL OF STEEL FRAME
 Cast frame to have same basic dimensions.

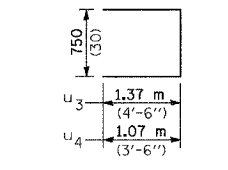

BARS U₃, U₄

INLET BOX

REQUIRED MATERIAL

TYPE F			
Bar	Qty.	Size	Length
u	8	No. 15 (No. 4)	3.23 m (10'-7")
u ₁	3	No. 15 (No. 4)	4.47 m (14'-8")
u ₃	6	No. 15 (No. 4)	3.49 m (11'-6")
Concrete	m ³ (cu. yds.)		1.3 (1.7)
Reinf. bars	kg (lbs.)		89.9 (126)
Grating	m ² (sq. ft.)		1.02 (10.9)

TYPE E			
Bar	Qty.	Size	Length
u	6	No. 15 (No. 4)	3.23 m (10'-7")
u ₂	3	No. 15 (No. 4)	3.83 m (12'-7")
u ₄	6	No. 15 (No. 4)	2.89 m (9'-6")
Concrete	m ³ (cu. yds.)		1.0 (1.3)
Reinf. bars	kg (lbs.)		71.9 (101)
Grating	m ² (sq. ft.)		0.68 (7.3)

GENERAL NOTES

See Standard 420001 for joint details not shown.

All exposed edges of the Inlet, except the upper perimeter, shall be beveled 20 mm (3/4").

For placement of drainage elements on existing construction with existing rigid pavement, substitute expansion anchor ties for tie bars. For nonrigid pavements or monolithic construction of pcc slab and shoulder, omit tie bars.

All dimensions are in millimeters (inches) unless otherwise shown.

INLET TYPE	SHOULDER WIDTH	O-O GRATING FRAME	INLET BOX INSIDE WIDTH	INLET BOX INSIDE LENGTH
Type E	2.4 m (8')	1.325 m (4'-4")	1.195 m (3'-11")	460 (18)
Type F	3.0 m (10')	1.960 m (6'-5")	1.830 m (6'-0")	460 (18)

REVISIONS	
NAME	DATE

ILLINOIS DEPARTMENT OF TRANSPORTATION

TYPE E INLET BOX STANDARD 610001 (SPECIAL) DETAIL

SCALE: VERT. HORIZ.
 DATE: 04/04/2005

DRAWN BY: RLH
 CHECKED BY: MED

TUC PROJ # 91292-5
 SHEET DETAIL S-W-69
 04/04/2005

F.A.S. RTE.	SECTION	COUNTY	TOTAL SHEETS	SHEET NO.
642	99-00124-01-PV	COLES	157	81
STA.		TO STA.		
FED. ROAD DIST. NO.		ILLINOIS	FED. AID PROJECT	

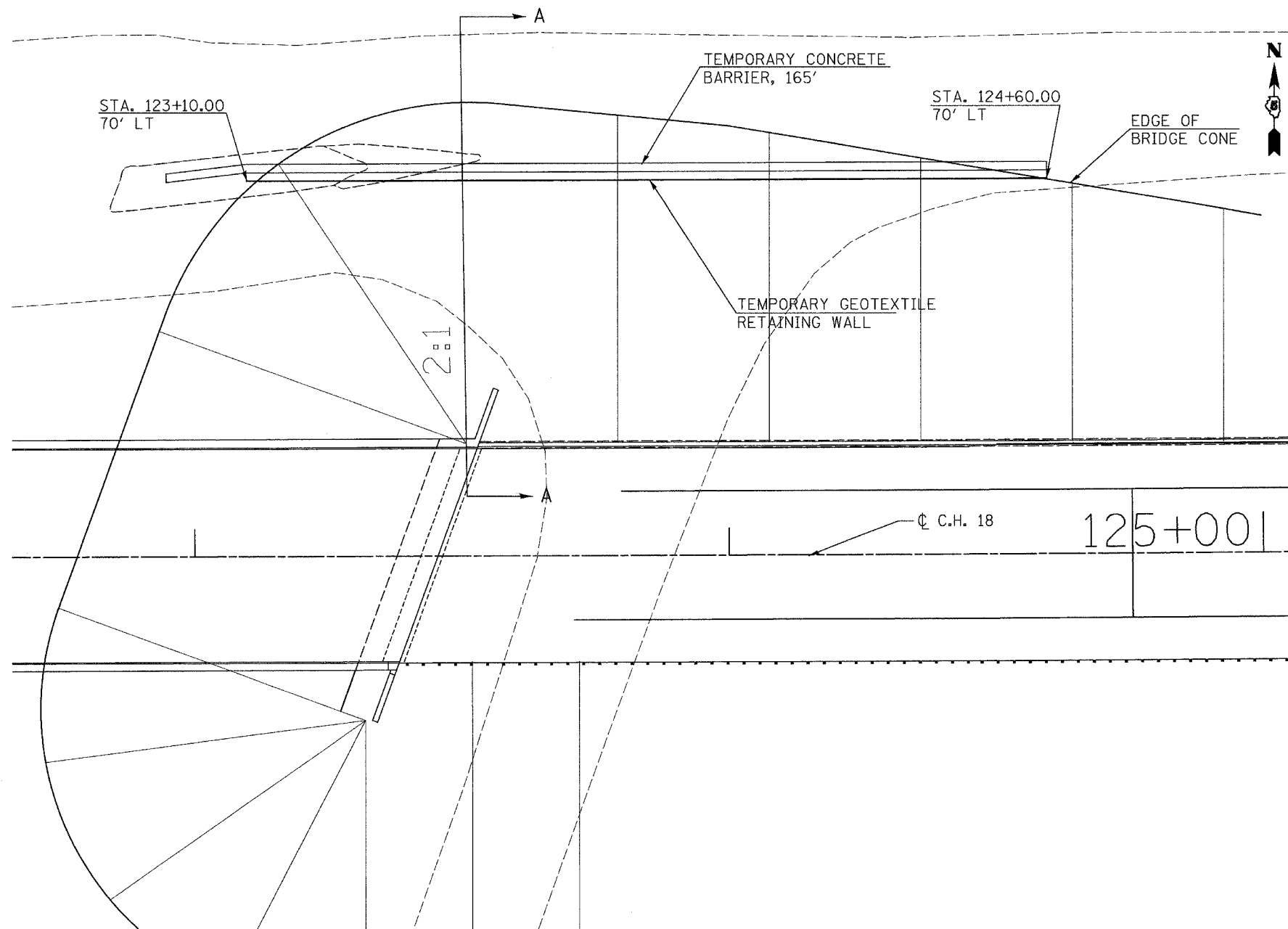

PLAN VIEW

BILL OF MATERIALS

Item	Unit	Qty.
Temporary Concrete Barrier	LIn Ft	165
Geotextile Retaining Wall	Sq Ft	804

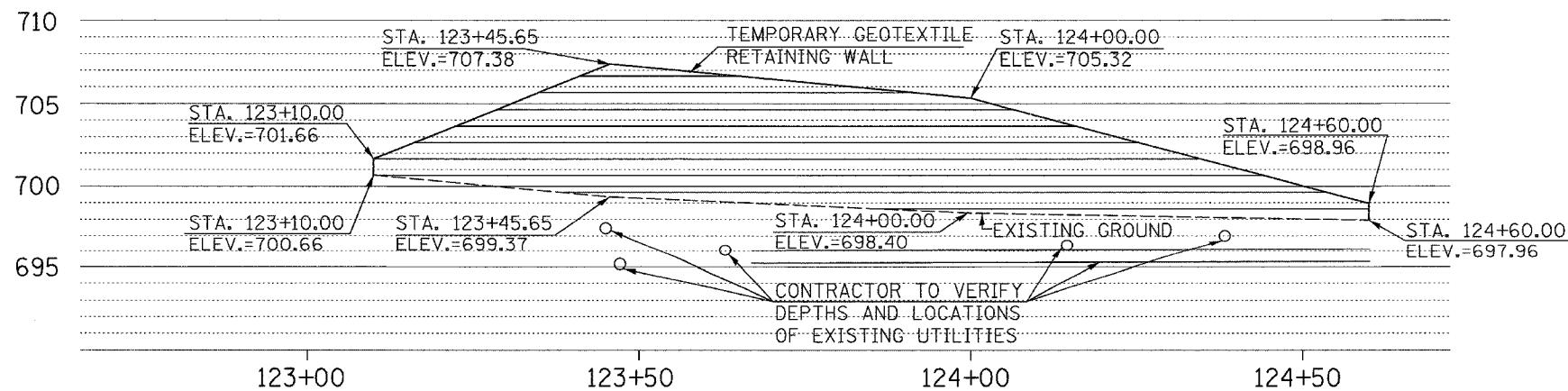

PROFILE VIEW

SHEET 1 OF 2

REVISIONS	
NAME	DATE

ILLINOIS DEPARTMENT OF TRANSPORTATION

TEMPORARY GEOTEXTILE RETAINING WALL

SCALE: VERT.
HORIZ.
DATE 08/11/2005

DRAWN BY RLH
CHECKED BY MED

TUG PROJ. #13091022-5
SHEET DETAILS-W.dgn
08/11/2005

F.A.S. RTE.	SECTION	COUNTY	TOTAL SHEETS	SHEET NO.
642	99-00124-01-PV	COLES	157	82
STA.	TO STA.			
FED. ROAD DIST. NO.	ILLINOIS	FED. AID PROJECT		

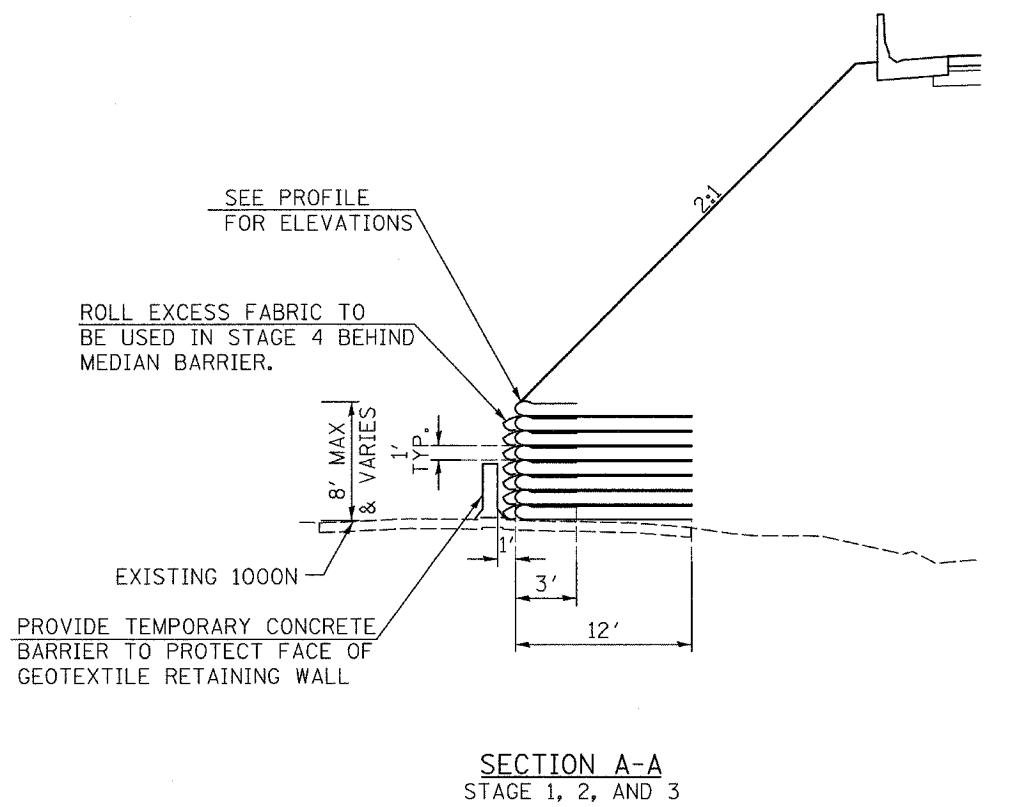

SECTION A-A
STAGE 1, 2, AND 3

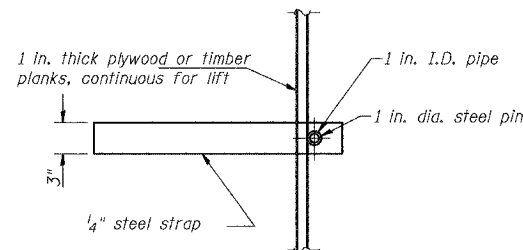

Note:
This is a suggested detail, the Contractor is responsible for the design of the form brace system to be used.

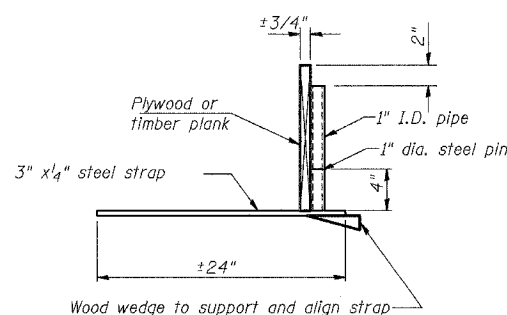

SUGGESTED GEOTEXTILE TEMPORARY
FORM BRACE SYSTEM DETAIL

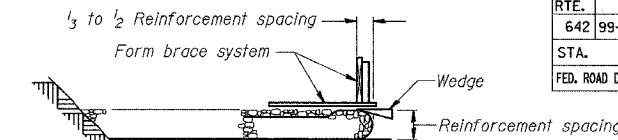

1. Place form brace system on completed reinforcement level; back from the finished fabric face a distance of $1/3$ to $1/2$ the reinforcement spacing.

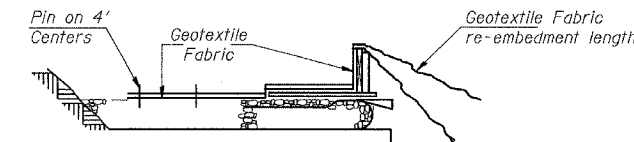

2. Position fabric so that the required re-embedment length extends over the top of the form brace and the design reinforcement width is placed with no slack against the previous level.

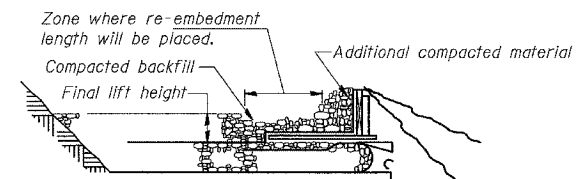

3. Compact backfill material in lifts to final lift height, create ± 3 in depression in zone where re-embedment length will be located and place additional height of compacted material against form brace.

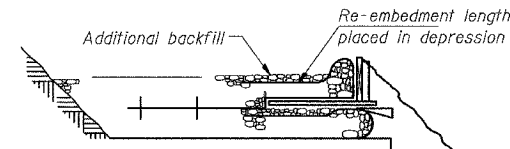

4. Fold fabric re-embedment length back over form brace into zone where depression was made in backfill and place additional compacted backfill, ± 3 in to embed fabric and bring to final lift height.

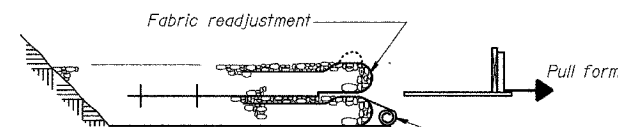

5. Pull form brace outward allowing fabric face to slightly readjust to form tight round face and level with plan reinforcement spacing. Roll unused layer of fabric to be incorporated into final earth embankment and place at base of wall behind median barrier to prevent damage to fabric.

**GEOTEXTILE WALL
CONSTRUCTION PROCEDURE**

Notes: The geotextile fabric shall have a minimum allowable tensile strength (T_{min}) of 0.45 kip/ft as determined by the procedure stated in the Special Provisions. The computations supporting the determination of (T_a) shall be submitted to the engineer for approval.

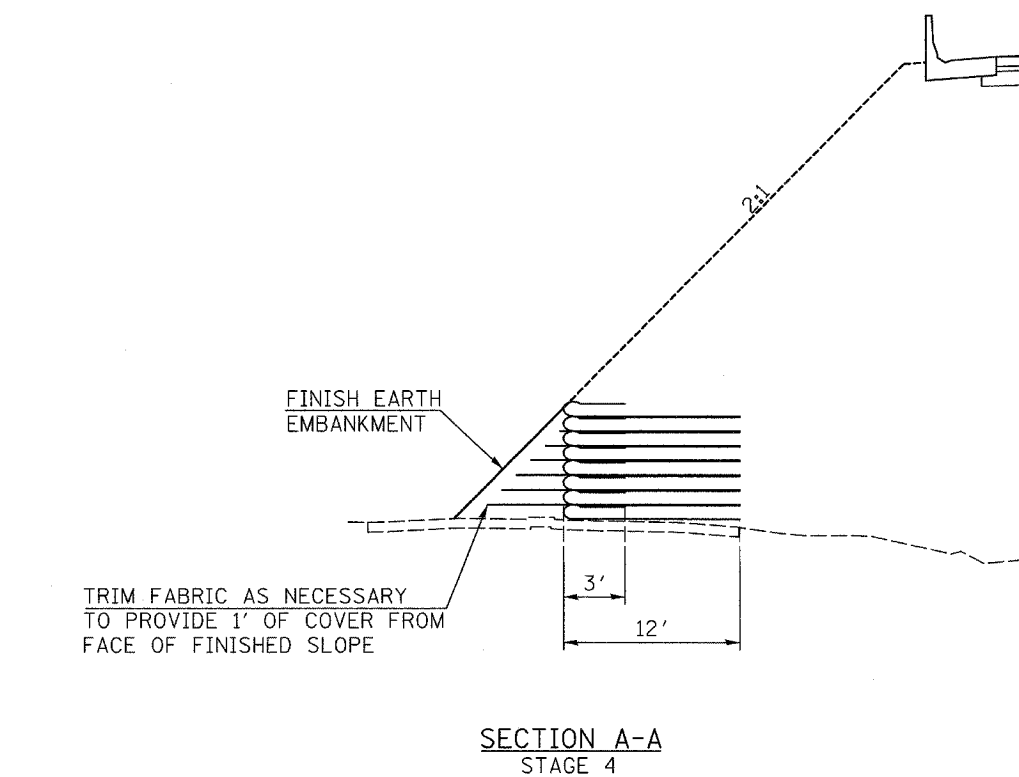

SECTION A-A
STAGE 4

REVISIONS		ILLINOIS DEPARTMENT OF TRANSPORTATION	
NAME	DATE	TEMPORARY GEOTEXTILE RETAINING WALL	

SCALE: VERT. DRAWN BY RLH
 HORIZ. CHECKED BY MED
 DATE 04/04/2005

TUC PROJ: #181022-5
 S-SHEET: DTA15-W.cgm
 04/04/2005

F.A.S. RTE.	SECTION	COUNTY	TOTAL SHEETS	SHEET NO.
642	99-00124-01-PV	COLES	157	83
STA. TO STA.		FED. ROAD DIST. NO. ILLINOIS FED. AID PROJECT		

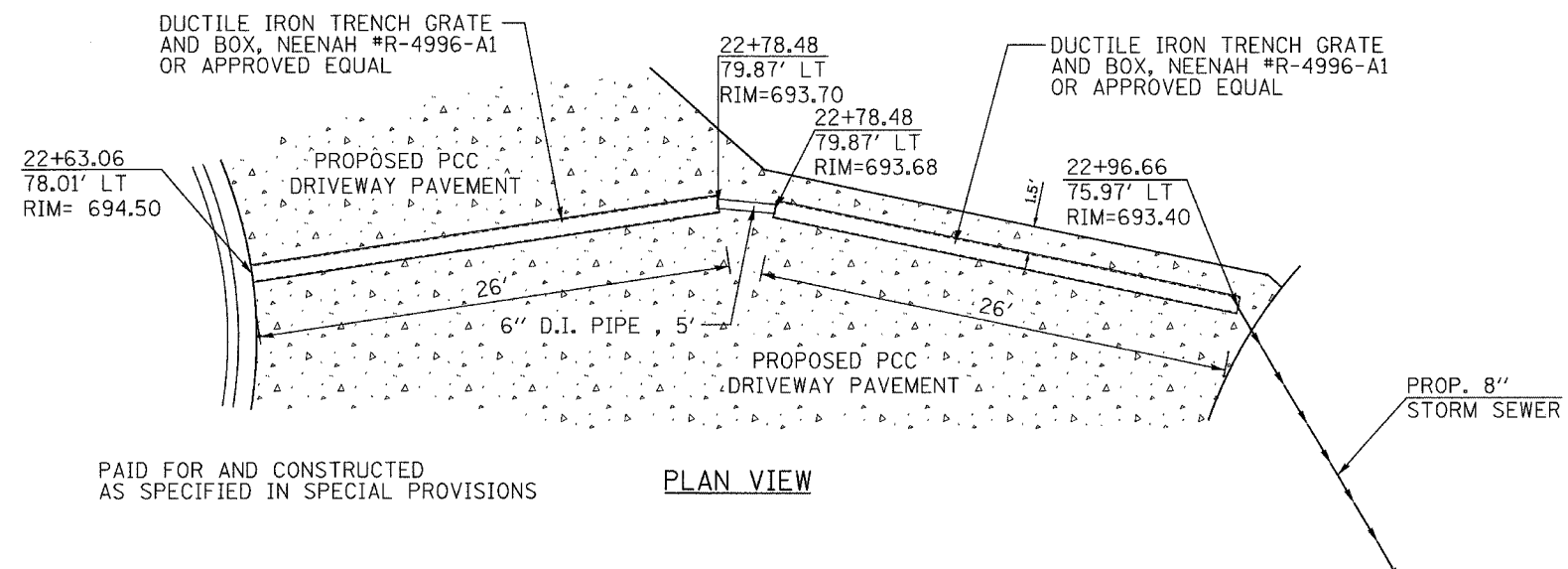

PAID FOR AND CONSTRUCTED AS SPECIFIED IN SPECIAL PROVISIONS

PLAN VIEW

TRENCH DRAIN

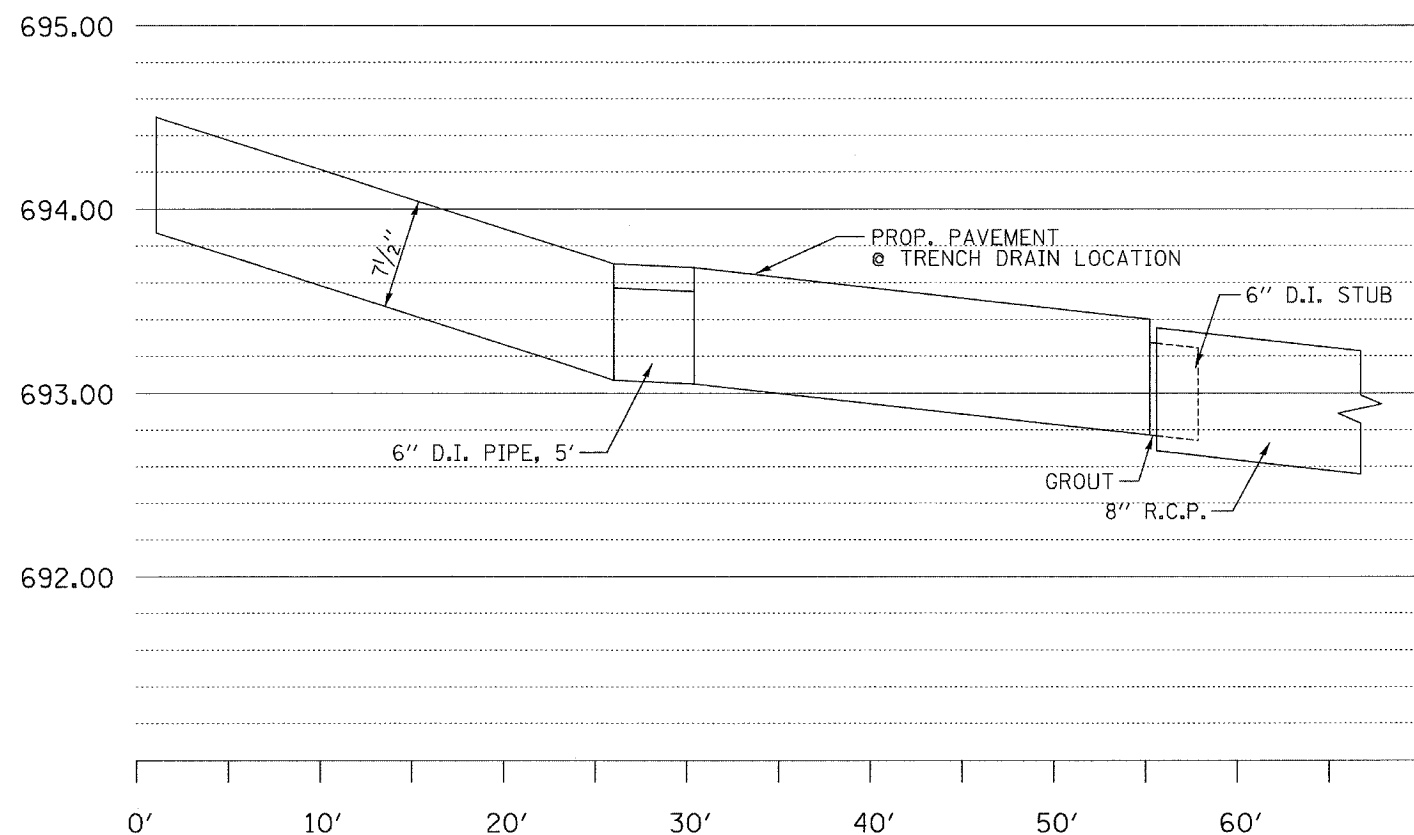

PROFILE VIEW

TRENCH DRAIN

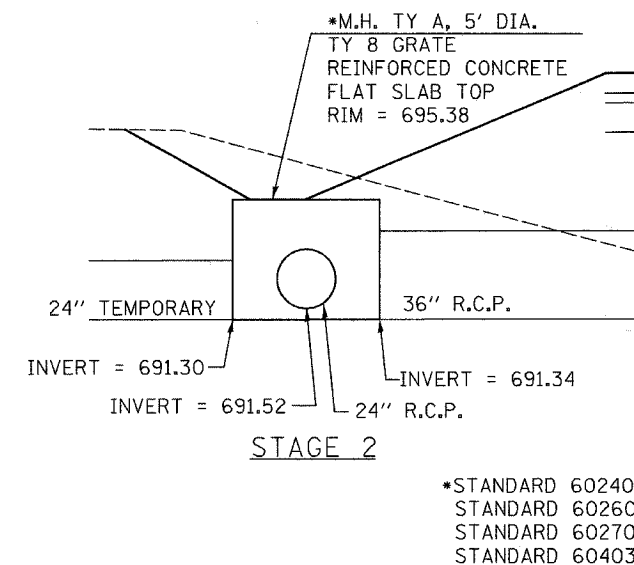
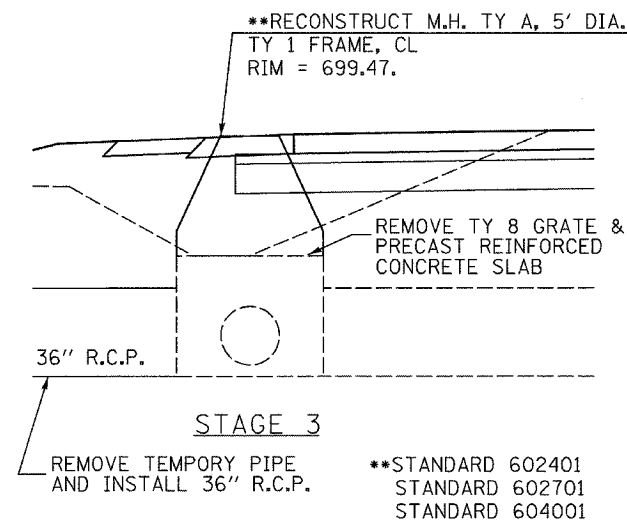

MANHOLE TYPE A, SPECIAL, 5' DIAMETER, TYPE 1 FRAME CLOSED LID
STATION 138+00 LEFT

REVISIONS	
NAME	DATE

ILLINOIS DEPARTMENT OF TRANSPORTATION

DRAINAGE STRUCTURE DETAILS

SCALE: VERT. HORIZ. DATE 09/02/2005

DRAWN BY RLH CHECKED BY MED

TUG PROJ. #1987022-5
...SHEETDETAILS-W.dgn
09/02/2005

Benchmark: B.M. 600A Top Cap Bolt next to M in Mueller.
1st F.H. E of Inters. 620E/1000N,
S. Side of Rd. Elev. 699.58
Existing Structure: None

Contract 91222

F.A.P. RTE.	SECTION	COUNTY	TOTAL SHEETS	SHEET NO.
642	99-00124-01-PV	COLES	157	84
STA.	TO STA.			
FED. ROAD DIST. NO.	ILLINOIS	FED. AID PROJECT		

Sheet 1 of 21 Sheets

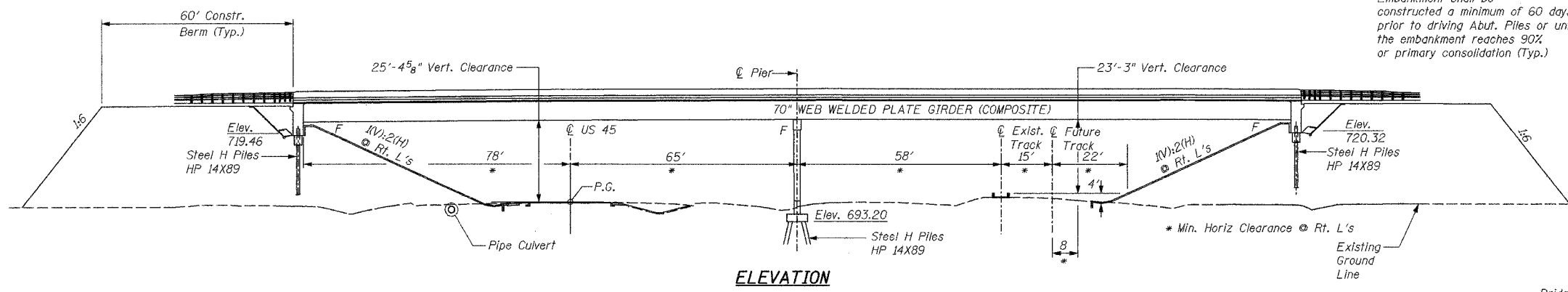

Embankment shall be constructed a minimum of 60 days prior to driving Abut. Piles or until the embankment reaches 90% or primary consolidation (Typ.)

PROFILE GRADE (RTE. 45)

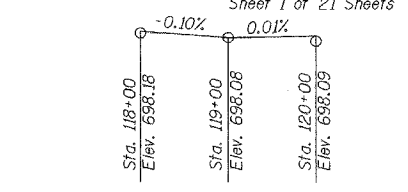

TOP OF RAIL ELEVATIONS

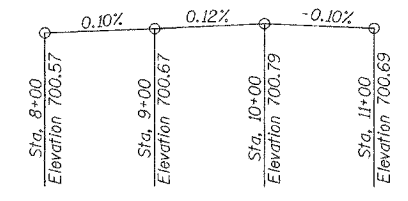

TOP OF RAIL ELEVATIONS

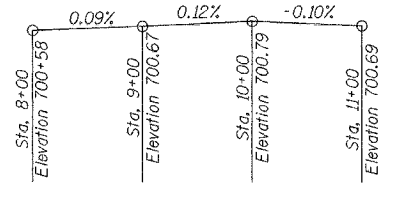

PROFILE GRADE (CH18)

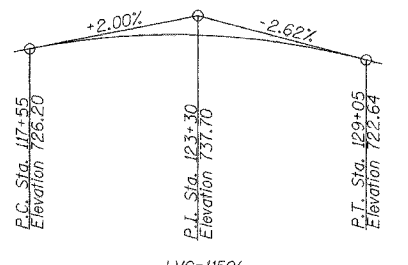

Along &

MARTIN J. SILVESTER
081-004378
LICENSED
STRUCTURAL
ENGINEER
OF
CHICAGO, ILLINOIS
10-06-05
MARTIN J. SILVESTER
STRUCTURAL ENGINEER
LICENSE EXP. DATE 11-30-06

I certify that to the best of my knowledge, information and belief, this bridge design is structurally adequate for the design loading shown on the plans. The design is an economical one for the style of structure and complies with requirements of the current AASHTO Standard Specifications for Highway Bridges.

ILLINOIS DEPARTMENT OF TRANSPORTATION
GENERAL PLAN
CH 18 OVER US 45 AND CN/IC RR
FAS 642 SECTION 99-00124-01-PV
COLES COUNTY
STA. 121+87.25 STR. No. 015-3400
SCALE: 1"=20'-0"
DATE: 1-21-2004
DRAWN BY LMP
CHECKED BY MJS

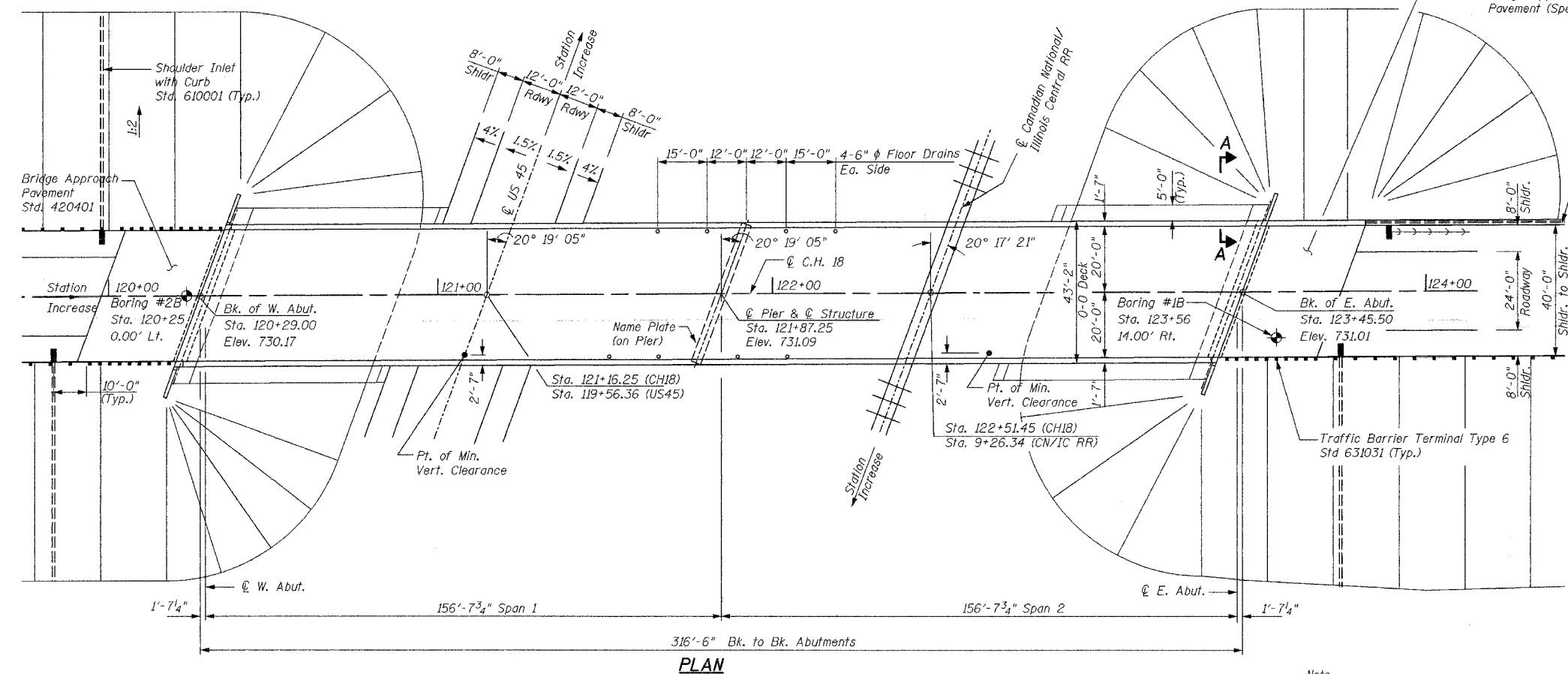

PLAN

Note:
For Section A-A see Sheet 3 of 21

DESIGN STRESSES

FIELD UNITS
f_c = 3500 psi
f_y = 60000 psi (Reinf.)
F_y = 50000 psi (Structural Steel)
(AASHTO M270 Grade 50)
F_y = 36000 psi (Structural Steel)
(AASHTO M270 Grade 36)

SEISMIC DATA

Seismic Performance Category (SPC) = A
Bedrock Acceleration Coefficient (A) = 0.058g
Site Coefficient (S) = 1.0

LOADING HS 20-44

Allow 50 Lb/Sq. Ft. for future wearing surface.

DESIGN SPECIFICATIONS

AASHTO 2002

STATION 121+87.25
BUILT 20 BY
COLES COUNTY
F.A.S. RT. 642 SEC. 99-00124-01-PV
LOADING HS20
STR. NO. 015-3400

NAME PLATE

See Std. 515001

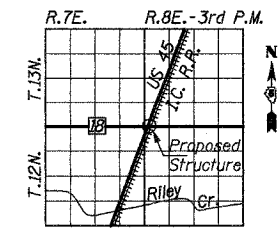

LOCATION SKETCH

REVISIONS	
NAME	DATE

THE UPCHURCH GROUP
HILLSIDE, IL. (708) 449-2321
MATTOON, IL. (217) 235-3177

F.A.P. RTE.	SECTION	COUNTY	TOTAL SHEETS	SHEET NO.
642	99-00124-01-PV	COLES	157	85
STA.		TO STA.		
FED. ROAD DIST. NO.		ILLINOIS FED. AID PROJECT		

GENERAL NOTES

- Fasteners shall be high strength bolts. Bolts 7/8" diameter, open holes 5/8" ϕ , unless otherwise noted.
- Calculated weight of Structural Steel = 455,990 lbs (AASHTO M270, Grade 50).
28,470 lbs (AASHTO M270, Grade 36).
- Field welding of construction accessories will not be permitted to beams or girders.
- Anchor bolts shall be set before bolting cross frames over supports.
- The main load carrying member components subject to tensile stress shall conform to the Supplemental Requirements for Notch Toughness Zone 2. These components are the tension flanges, webs and all splice plate material except fill plates.
- Reinforcement bars shall conform to the requirements of AASHTO M31 or M322 Grade 60.
- Slope Wall shall be reinforced with welded wire fabric 6"x6" - W4.0 x W4.0, weighing 58 lbs. per 100 sq. ft.
- The embankment configuration shown shall be the minimum embankment that must be constructed prior to construction of the abutments.
- Bearing seat surfaces shall be constructed or adjusted to the designated elevations within a tolerance of 1/8 inch. Adjustment shall be made either by grinding the surface or by shimming the bearing. Two 1/8" adjusting shims, of the dimensions of the bottom bearing plate, shall be provided for each bearing in addition to all other plates or shims.
- Piles at abutments shall be driven in holes precored through the embankment according to Article 512.10 (c) of the Standard Specifications.
- The Contractor shall drive 2 Steel HP14x89 test piles in a permanent location, one at the Pier and one at the west abutment, as directed by the Engineer before ordering the remainder of the piles.
- All construction joints shall be bonded.
 - When the Deck pour is stopped for the day at one or more of the transverse Bonded Construction Joints in the Deck Pouring Sequence as shown, The next pour shall not be made until both of the following requirements are met:
 - At least 72 hours shall have elapsed from the end of the previous pour.
 - The concrete strength shall have attained a minimum flexural strength of 650 psi or a minimum compressive strength of 3500 psi
- The inorganic zinc rich primer/ Acrylic/ Acrylic Paint System shall be used for shop and field painting of new structural steel except where otherwise noted. The color of the final finish coat for all interior steel surfaces shall be light gray, Munsell No. 10Y7/1. The color of the final finish coat for the exterior and bottom flange of the fascia beams shall be Interstate Green Munsell color standard 7.5G 4/8. See special provision for "Cleaning and Painting New Metal Structures."

TOTAL BILL OF MATERIAL

ITEM	UNIT	SUPER	SUB	TOTAL
Porous Granular Embankment (Special)	Cu. Yd.		362	362
Structure Excavation	Cu. Yd.		618	618
Bridge Deck Grooving	Sq. Yd.	1337		1337
Protective Coat	Sq. Yd.	1672		1672
Concrete Structures	Cu. Yd.		142.4	142.4
Concrete Superstructure	Cu. Yd.	486.8		486.8
Reinforcement Bars, Epoxy Coated	Lb	102270	26640	128910
Floor Drains	Each	8		8
Name Plates	Each		1	1
Furnishing Steel Piles HP 14X89	Ft.		2687	2687
Driving Steel Piles	Ft.		2687	2687
Test Pile Steel HP 14x89	Each	2		2
Furnishing and Erecting Structural Steel	L. Sum	1		1
Stud Shear Connectors	Each	2400		2400
Slope Wall 4 inch	Sq. Yd.		825	825
Bar Splicers	Each	80		80

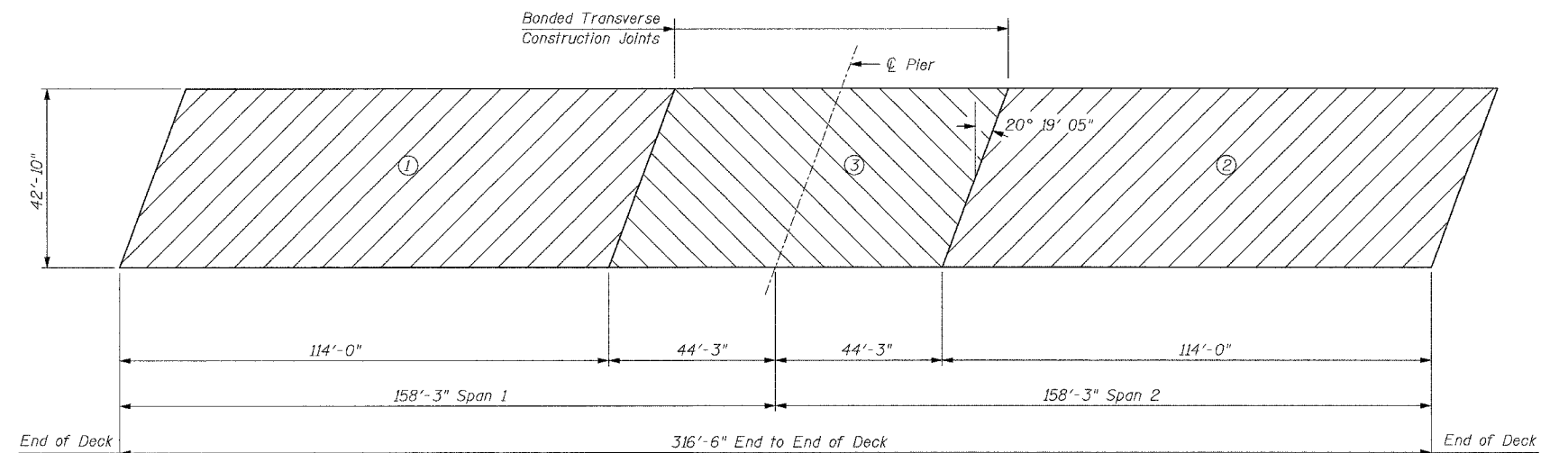

DECK POURING SEQUENCE

The Concrete Deck Segments shall be poured in the numerical order shown above. Pour ① and ② shall be completed on the same day.

THE UPCHURCH GROUP

HILLSIDE, IL. (708) 449-2321
MATTOON, IL. (217) 235-3177

REVISIONS	
NAME	DATE

ILLINOIS DEPARTMENT OF TRANSPORTATION
GENERAL NOTES, BILL OF MATERIAL
CH 18 OVER US 45 AND CN/IC RR
FAS 642 SECTION 99-00124-01-PV
COLES COUNTY
STA. 121+87.25 STR. No. 015-3400

SCALE: DRAWN BY LMP
DATE: 6/21/05 CHECKED BY MJS

F.A.P. RTE.	SECTION	COUNTY	TOTAL SHEETS	SHEET NO.
642	99-00124-01-PV	COLES	157	86
STA.	TO STA.			
FED. ROAD DIST. NO.	ILLINOIS	FED. AID PROJECT		

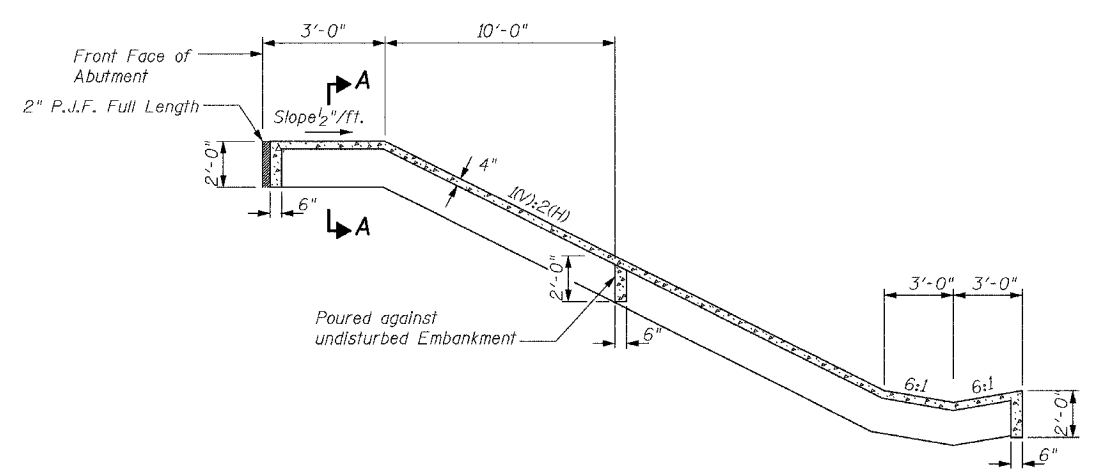

SECTION THRU SLOPEWALL
(All dimension at Rt. L's)

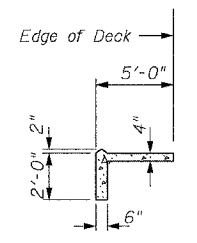

SECTION A-A

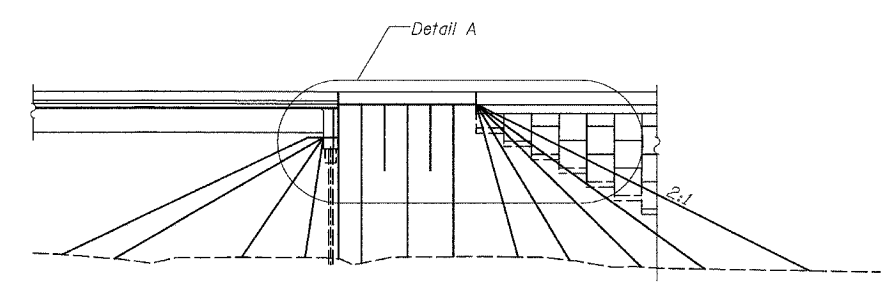

EAST ABUTMENT - VIEW WITH RETAINING WALL

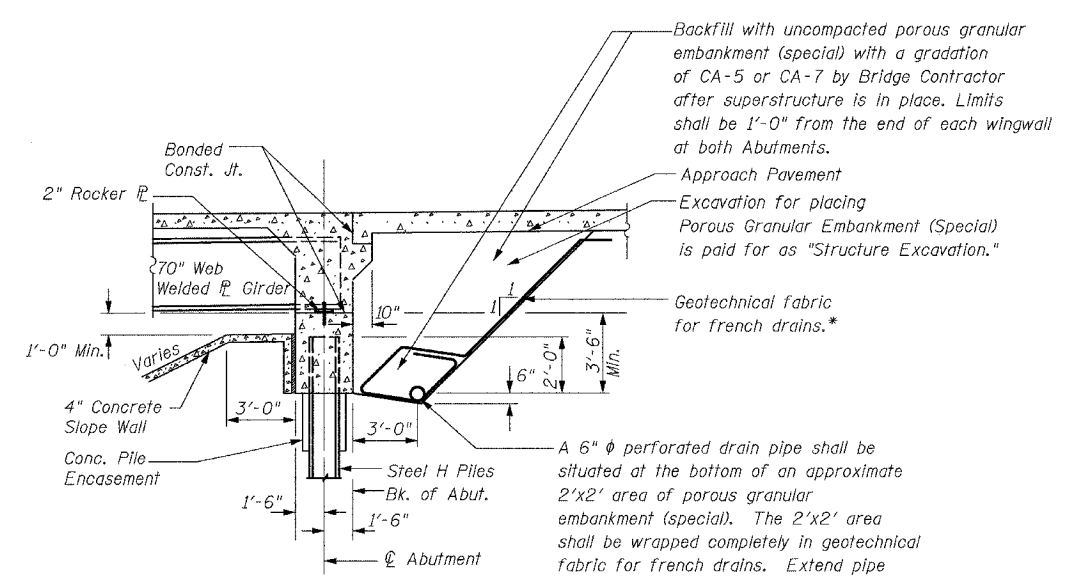

SECTION THRU INTEGRAL ABUTMENT
(At Rt. L's)

* Included in the cost of "Porous Granular Embankment (Special)."

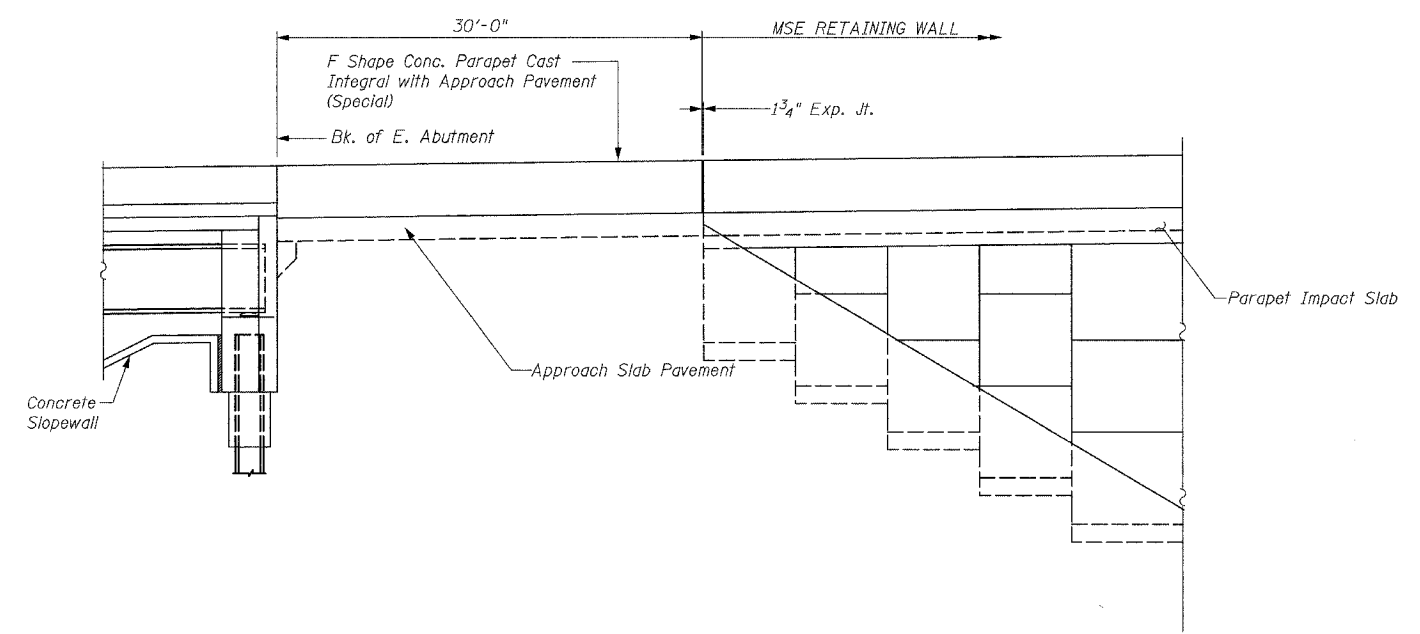

DETAIL A

THE UPCHURCH GROUP
HILLSIDE, IL. (708) 449-2821
MATTOON, IL. (217) 235-3177

REVISIONS	
NAME	DATE

ILLINOIS DEPARTMENT OF TRANSPORTATION
SLOPE WALL & INTEGRAL ABUT. DETAILS
CH 18 OVER US 45 AND CN/IC RR
FAS 642 SECTION 99-00124-01-PV
COLES COUNTY
STA. 121+87.25 STR. No. 015-3400
SCALE: DRAWN BY BJF
DATE: 6/21/05 CHECKED BY MJS

F.A.P. RTE.	SECTION	COUNTY	TOTAL SHEETS	SHEET NO.
642	99-00124-01-PV	COLES	157	87
STA.		TO STA.		
FED. ROAD DIST. NO.	ILLINOIS	FED. AID PROJECT		

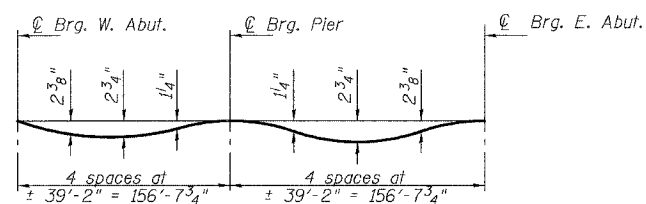

DEAD LOAD DEFLECTION DIAGRAM

(Includes weight of concrete only.)

Note: The above deflections are not to be used in the field if the engineer is working from the grade elevations adjusted for dead load deflections as shown on Sheets 5 and 6.

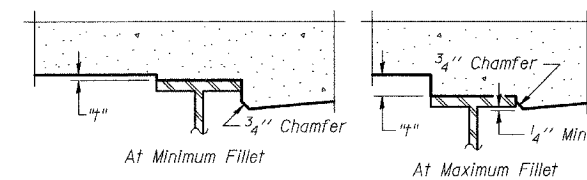

To determine "t": After all structural steel has been erected, elevations of the top flanges of the beams shall be taken at intervals shown below. These elevations subtracted from the "Theoretical Grade Elevations Adjusted for Dead Load Deflection" shown on Sheets 5 and 6, minus slab thickness, equals the fillet heights "t" above top flange of beams.

FILLET HEIGHTS

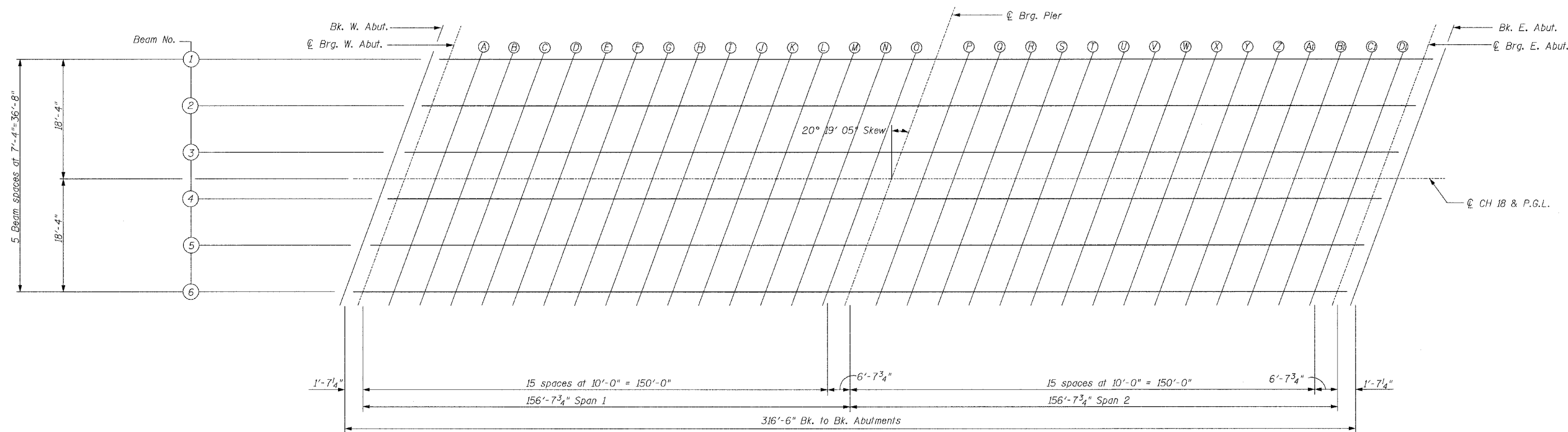

PLAN

Note: Work this Sheet with Sheets 5 and 6 of 21.

THE UPCHURCH GROUP

HILLSIDE, IL. (708) 449-2321
MATTOON, IL. (217) 235-8177

E-S 4-30-97

REVISIONS	
NAME	DATE

ILLINOIS DEPARTMENT OF TRANSPORTATION
TOP OF SLAB ELEVATIONS
CH 18 OVER US 45 AND CN/IC RR
FAS 642 SECTION 99-00124-01-PV
COLES COUNTY
STA. 121+87.25 STR. No. 015-3400

SCALE: N.T.S. DRAWN BY B.J.F.
DATE: 01-21-2004 CHECKED BY M.J.S.

F.A.P. RTE.	SECTION	COUNTY	TOTAL SHEETS	SHEET NO.
642	99-00124-01-PV	COLES	157	88
STA.		TO STA.		
FED. ROAD DIST. NO.		ILLINOIS FED. AID PROJECT		

BEAM 1

Location	Station	Offset	Theoretical Grade Elevations	Theoretical Grade Elevations Adjusted For Dead Load Deflection
Back of West Abut.	120+35.79	18.33'	729.91	729.91
☉ Brg. West Abut.	120+37.39	18.33'	729.93	729.93
A	120+47.39	18.33'	730.01	730.07
B	120+57.39	18.33'	730.09	730.21
C	120+67.39	18.33'	730.17	730.33
D	120+77.39	18.33'	730.24	730.44
E	120+87.39	18.33'	730.31	730.54
F	120+97.39	18.33'	730.37	730.61
G	121+07.39	18.33'	730.43	730.67
H	121+17.39	18.33'	730.49	730.71
I	121+27.39	18.33'	730.54	730.74
J	121+37.39	18.33'	730.59	730.76
K	121+47.39	18.33'	730.64	730.76
L	121+57.39	18.33'	730.68	730.76
M	121+67.39	18.33'	730.71	730.76
N	121+77.39	18.33'	730.74	730.77
O	121+87.39	18.33'	730.77	730.78
☉ Brg. Pier	121+94.04	18.33'	730.79	730.79
P	122+04.04	18.33'	730.81	730.82
Q	122+14.04	18.33'	730.83	730.86
R	122+24.04	18.33'	730.84	730.91
S	122+34.04	18.33'	730.85	730.95
T	122+44.04	18.33'	730.86	731.00
U	122+54.04	18.33'	730.86	731.04
V	122+64.04	18.33'	730.86	731.07
W	122+74.04	18.33'	730.85	731.08
X	122+84.04	18.33'	730.84	731.08
Y	122+94.04	18.33'	730.82	731.06
Z	123+04.04	18.33'	730.81	731.03
A ₁	123+14.04	18.33'	730.78	731.97
B ₁	123+24.04	18.33'	730.76	730.91
C ₁	123+34.04	18.33'	730.73	730.82
D ₁	123+44.04	18.33'	730.69	730.73
☉ Brg. East Abut.	123+50.69	18.33'	730.67	730.67
Back of East Abut.	123+52.29	18.33'	730.66	730.66

BEAM 2

Location	Station	Offset	Theoretical Grade Elevations	Theoretical Grade Elevations Adjusted For Dead Load Deflection
Back of West Abut.	120+33.07	11.00'	730.04	730.04
☉ Brg. West Abut.	120+34.67	11.00'	730.05	730.05
A	120+44.67	11.00'	730.14	730.20
B	120+54.67	11.00'	730.22	730.33
C	120+64.67	11.00'	730.30	730.46
D	120+74.67	11.00'	730.37	730.57
E	120+84.67	11.00'	730.44	730.66
F	120+94.67	11.00'	730.50	730.74
G	121+04.67	11.00'	730.57	730.80
H	121+14.67	11.00'	730.62	730.85
I	121+24.67	11.00'	730.68	730.88
J	121+34.67	11.00'	730.73	730.89
K	121+44.67	11.00'	730.77	730.90
L	121+54.67	11.00'	730.81	730.90
M	121+64.67	11.00'	730.85	730.90
N	121+74.67	11.00'	730.88	730.91
O	121+84.67	11.00'	730.91	730.92
☉ Brg. Pier	121+91.32	11.00'	730.93	730.93
P	122+01.32	11.00'	730.95	730.96
Q	122+11.32	11.00'	730.97	731.00
R	122+21.32	11.00'	730.99	731.05
S	122+31.32	11.00'	731.00	731.10
T	122+41.32	11.00'	731.00	731.15
U	122+51.32	11.00'	731.01	731.18
V	122+61.32	11.00'	731.01	731.21
W	122+71.32	11.00'	731.00	731.23
X	122+81.32	11.00'	730.99	731.23
Y	122+91.32	11.00'	730.98	731.21
Z	123+01.32	11.00'	730.96	731.18
A ₁	123+11.32	11.00'	730.94	731.13
B ₁	123+21.32	11.00'	730.91	731.06
C ₁	123+31.32	11.00'	730.88	731.98
D ₁	123+41.32	11.00'	730.85	730.89
☉ Brg. East Abut.	123+47.97	11.00'	730.82	730.82
Back of East Abut.	123+49.57	11.00'	730.82	730.82

BEAM 3

Location	Station	Offset	Theoretical Grade Elevations	Theoretical Grade Elevations Adjusted For Dead Load Deflection
Back of West Abut.	120+30.36	3.67'	730.13	730.13
☉ Brg. West Abut.	120+31.96	3.67'	730.15	730.15
A	120+41.96	3.67'	730.23	730.29
B	120+51.96	3.67'	730.32	730.43
C	120+61.96	3.67'	730.39	730.56
D	120+71.96	3.67'	730.47	730.67
E	120+81.96	3.67'	730.54	730.77
F	120+91.96	3.67'	730.61	730.84
G	121+01.96	3.67'	730.67	730.91
H	121+11.96	3.67'	730.73	730.95
I	121+21.96	3.67'	730.78	730.98
J	121+31.96	3.67'	730.83	731.00
K	121+41.96	3.67'	730.88	731.01
L	121+51.96	3.67'	730.92	731.01
M	121+61.96	3.67'	730.96	731.01
N	121+71.96	3.67'	730.99	731.02
O	121+81.96	3.67'	731.03	731.03
☉ Brg. Pier	121+88.61	3.67'	731.04	731.04
P	121+98.61	3.67'	731.07	731.08
Q	122+08.61	3.67'	731.09	731.12
R	122+18.61	3.67'	731.10	731.17
S	122+28.61	3.67'	731.11	731.22
T	122+38.61	3.67'	731.12	731.26
U	122+48.61	3.67'	731.13	731.30
V	122+58.61	3.67'	731.13	731.33
W	122+68.61	3.67'	731.12	731.35
X	122+78.61	3.67'	731.11	731.35
Y	122+88.61	3.67'	731.10	731.33
Z	122+98.61	3.67'	731.08	731.30
A ₁	123+08.61	3.67'	731.06	731.25
B ₁	123+18.61	3.67'	731.04	731.19
C ₁	123+28.61	3.67'	731.01	731.11
D ₁	123+38.61	3.67'	730.98	731.02
☉ Brg. East Abut.	123+45.26	3.67'	730.95	730.95
Back of East Abut.	123+46.86	3.67'	730.95	730.95

Note: Work this Sheet with Sheet 4 of 21.

THE UPCHURCH GROUP

HILLSIDE, IL. (708) 449-2321
MATTOON, IL. (217) 235-3177

REVISIONS	
NAME	DATE

ILLINOIS DEPARTMENT OF TRANSPORTATION
TOP OF SLAB FAS 642
CH 18 OVER
FAS 642

STA. 121+87.2

SCALE: N.T.S.

DATE: 01-21-2004

F.A.P. RITE.	SECTION	COUNTY	TOTAL SHEETS	SHEET NO.
642	99-00124-01-PV	COLES	157	89
STA.		TO STA.		
FED. ROAD DIST. NO.		ILLINOIS	FED. AID PROJECT	

CH 18 & PGL

Location	Station	Offset	Theoretical Grade Elevations	Theoretical Grade Elevations Adjusted For Dead Load Deflection
Back of West Abut.	120+29.00	0	730.17	730.17
☉ Brg. West Abut.	120+30.60	0	730.19	730.19
A	120+40.60	0	730.27	730.33
B	120+50.60	0	730.36	730.47
C	120+60.60	0	730.44	730.60
D	120+70.60	0	730.51	730.71
E	120+80.60	0	730.58	730.81
F	120+90.60	0	730.65	730.89
G	121+00.60	0	730.71	730.95
H	121+10.60	0	730.77	731.00
I	121+20.60	0	730.83	731.03
J	121+30.60	0	730.88	731.04
K	121+40.60	0	730.93	731.05
L	121+50.60	0	730.97	731.06
M	121+60.60	0	731.01	731.06
N	121+70.60	0	731.04	731.06
O	121+80.60	0	731.07	731.08
☉ Brg. Pier	121+87.25	0	731.09	731.09
P	121+97.25	0	731.12	731.13
Q	122+07.25	0	731.14	731.17
R	122+17.25	0	731.15	731.22
S	122+27.25	0	731.17	731.27
T	122+37.25	0	731.17	731.31
U	122+47.25	0	731.18	731.36
V	122+57.25	0	731.18	731.39
W	122+67.25	0	731.17	731.40
X	122+77.25	0	731.17	731.41
Y	122+87.25	0	731.15	731.39
Z	122+97.25	0	731.14	731.36
A _i	123+07.25	0	731.12	731.31
B _i	123+17.25	0	731.10	731.24
C _i	123+27.25	0	731.07	731.16
D _i	123+37.25	0	731.04	731.08
☉ Brg. East Abut.	123+43.90	0	731.01	731.01
Back of East Abut.	123+45.50	0	731.01	731.01

BEAM 4

Location	Station	Offset	Theoretical Grade Elevations	Theoretical Grade Elevations Adjusted For Dead Load Deflection
Back of West Abut.	120+27.64	3.67'	730.11	730.11
☉ Brg. West Abut.	120+29.24	3.67'	730.12	730.12
A	120+39.24	3.67'	730.21	730.27
B	120+49.24	3.67'	730.29	730.41
C	120+59.24	3.67'	730.37	730.54
D	120+69.24	3.67'	730.45	730.65
E	120+79.24	3.67'	730.52	730.75
F	120+89.24	3.67'	730.59	730.83
G	120+99.24	3.67'	730.65	730.89
H	121+09.24	3.67'	730.71	730.94
I	121+19.24	3.67'	730.77	730.97
J	121+29.24	3.67'	730.82	730.99
K	121+39.24	3.67'	730.87	731.00
L	121+49.24	3.67'	730.91	731.00
M	121+59.24	3.67'	730.95	731.00
N	121+69.24	3.67'	730.99	731.01
O	121+79.24	3.67'	731.02	731.02
☉ Brg. Pier	121+85.89	3.67'	731.04	731.04
P	121+95.89	3.67'	731.06	731.07
Q	122+05.89	3.67'	731.08	731.11
R	122+15.89	3.67'	731.10	731.16
S	122+25.89	3.67'	731.11	731.21
T	122+35.89	3.67'	731.12	731.26
U	122+45.89	3.67'	731.13	731.30
V	122+55.89	3.67'	731.13	731.33
W	122+65.89	3.67'	731.12	731.35
X	122+75.89	3.67'	731.12	731.35
Y	122+85.89	3.67'	731.10	731.34
Z	122+95.89	3.67'	731.09	731.31
A _i	123+05.89	3.67'	731.07	731.26
B _i	123+15.89	3.67'	731.05	731.19
C _i	123+25.89	3.67'	731.02	731.12
D _i	123+35.89	3.67'	730.99	731.03
☉ Brg. East Abut.	123+42.54	3.67'	730.96	730.96
Back of East Abut.	123+44.14	3.67'	730.96	730.96

BEAM 5

Location	Station	Offset	Theoretical Grade Elevations	Theoretical Grade Elevations Adjusted For Dead Load Deflection
Back of West Abut.	120+24.93	11.00'	729.96	729.96
☉ Brg. West Abut.	120+26.53	11.00'	729.98	729.98
A	120+36.53	11.00'	730.07	730.13
B	120+46.53	11.00'	730.15	730.27
C	120+56.53	11.00'	730.23	730.40
D	120+66.53	11.00'	730.31	730.51
E	120+76.53	11.00'	730.38	730.61
F	120+86.53	11.00'	730.45	730.69
G	120+96.53	11.00'	730.52	730.75
H	121+06.53	11.00'	730.58	730.80
I	121+16.53	11.00'	730.63	730.83
J	121+26.53	11.00'	730.69	730.85
K	121+36.53	11.00'	730.73	730.86
L	121+46.53	11.00'	730.78	730.87
M	121+56.53	11.00'	730.82	730.87
N	121+66.53	11.00'	730.86	730.88
O	121+76.53	11.00'	730.89	730.89
☉ Brg. Pier	121+83.18	11.00'	730.91	730.91
P	121+93.18	11.00'	730.94	730.94
Q	122+03.18	11.00'	730.96	730.99
R	122+13.18	11.00'	730.97	731.04
S	122+23.18	11.00'	730.99	731.09
T	122+33.18	11.00'	731.00	731.14
U	122+43.18	11.00'	731.00	731.18
V	122+53.18	11.00'	731.01	731.22
W	122+63.18	11.00'	731.00	731.23
X	122+73.18	11.00'	731.00	731.24
Y	122+83.18	11.00'	730.99	731.22
Z	122+93.18	11.00'	730.97	731.19
A _i	123+03.18	11.00'	730.96	731.15
B _i	123+13.18	11.00'	730.93	731.08
C _i	123+23.18	11.00'	730.91	731.00
D _i	123+33.18	11.00'	730.88	730.92
☉ Brg. East Abut.	123+39.83	11.00'	730.85	730.85
Back of East Abut.	123+41.43	11.00'	730.85	730.85

BEAM 6

Location	Station	Offset	Theoretical Grade Elevations	Theoretical Grade Elevations Adjusted For Dead Load Deflection
Back of West Abut.	120+22.21	18.33'	729.79	729.79
☉ Brg. West Abut.	120+23.81	18.33'	729.81	729.81
A	120+33.81	18.33'	729.90	729.96
B	120+43.81	18.33'	729.98	730.10
C	120+53.81	18.33'	730.06	730.23
D	120+63.81	18.33'	730.14	730.34
E	120+73.81	18.33'	730.22	730.44
F	120+83.81	18.33'	730.29	730.52
G	120+93.81	18.33'	730.35	730.59
H	121+03.81	18.33'	730.41	730.64
I	121+13.81	18.33'	730.47	730.67
J	121+23.81	18.33'	730.52	730.69
K	121+33.81	18.33'	730.57	730.70
L	121+43.81	18.33'	730.62	730.71
M	121+53.81	18.33'	730.66	730.71
N	121+63.81	18.33'	730.70	730.72
O	121+73.81	18.33'	730.73	730.74
☉ Brg. Pier	121+80.46	18.33'	730.75	730.75
P	121+90.46	18.33'	730.78	730.79
Q	122+00.46	18.33'	730.80	730.83
R	122+10.46	18.33'	730.82	730.89
S	122+20.46	18.33'	730.84	730.94
T	122+30.46	18.33'	730.85	730.99
U	122+40.46	18.33'	730.86	731.03
V	122+50.46	18.33'	730.86	731.07
W	122+60.46	18.33'	730.86	731.09
X	122+70.46	18.33'	730.85	731.09
Y	122+80.46	18.33'	730.84	731.08
Z	122+90.46	18.33'	730.83	731.05
A _i	123+00.46	18.33'	730.81	731.00
B _i	123+10.46	18.33'	730.79	730.94
C _i	123+20.46	18.33'	730.77	730.86
D _i	123+30.46	18.33'	730.74	730.78
☉ Brg. East Abut.	123+37.11	18.33'	730.72	730.72
Back of East Abut.	123+38.71	18.33'	730.71	730.71

Note: Work this Sheet with Sheet 4 of 21.

THE UPCHURCH GROUP

HILLSIDE, IL. (708) 449-2321
MATTOON, IL. (217) 235-3177

REVISIONS	
NAME	DATE

ILLINOIS DEPARTMENT OF TRANSPORTATION
TOP OF SLAB ELEVATIONS 3
CH 18 OVER US 45 AND CN/IC RR
FAS 642 SECTION 99-00124-01-PV
COLES COUNTY
STA. 121+87.25 STR. No. 015-3400
SCALE: N.T.S. DRAWN BY JAU
DATE: 01-21-2004 CHECKED BY MJS

F.A.P. RTE.	SECTION	COUNTY	TOTAL SHEETS	SHEET NO.
642	99-00124-01-PV	COLES	157	90
STA.		TO STA.		
FED. ROAD DIST. NO.		ILLINOIS FED. AID PROJECT		

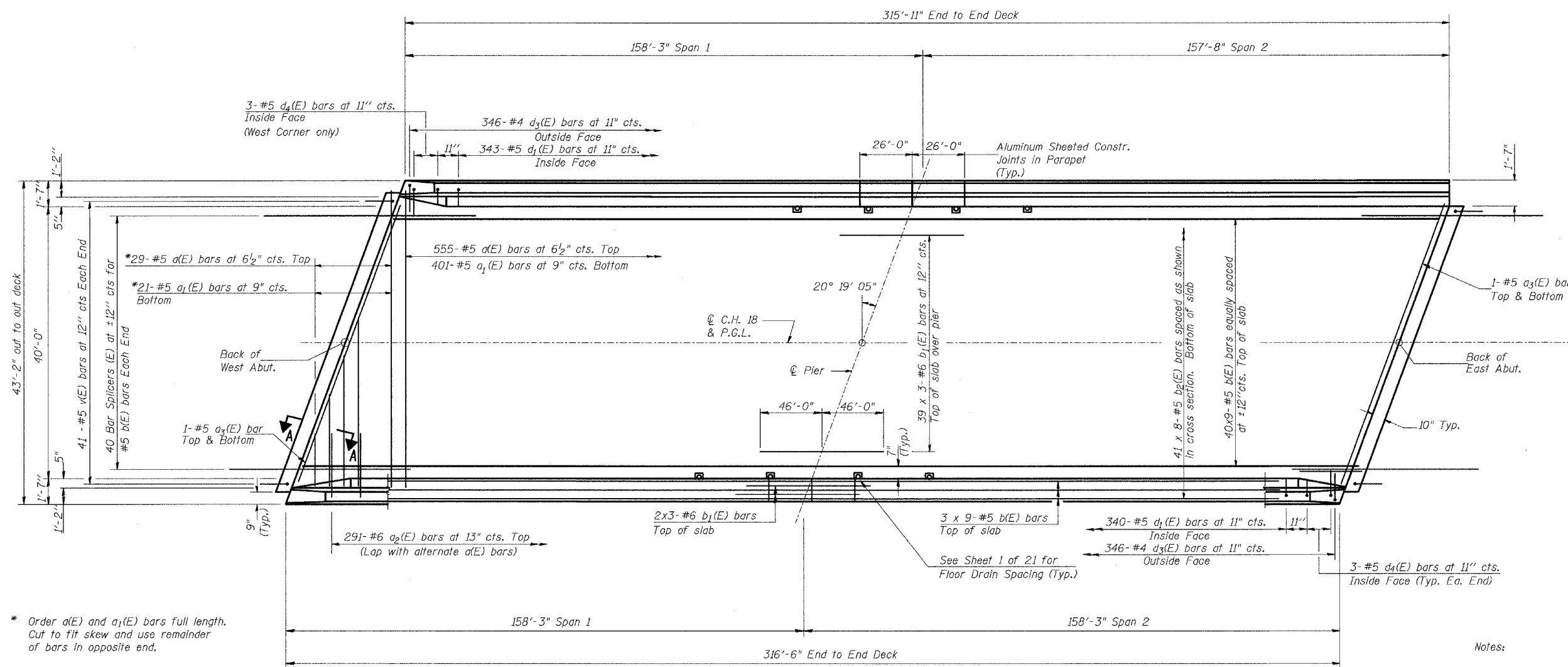

PLAN

* Order a(E) and a₁(E) bars full length. Cut to fit skew and use remainder of bars in opposite end.

- Notes:
- See Sheet 9 of 21 for superstructure details and Bill of Material.
 - Reinforcement bars designated (E) shall be epoxy coated.
 - Bars indicated thus 36 x 9-#5 etc. indicates 36 lines of bars with 9 lengths per line.
 - See Sheet 9 of 21 for parapet reinforcement.
 - Reinforcement bars shown on this sheet are included in Bill of Material on Sheet 9 of 21.
 - See Sheet 8 of 21 for details of End Diaphragm and Section A-A.
 - Work this sheet with Sheet 8 and 9 of 21.
 - See sheet 18 of 21 for Bar Splicer Details.

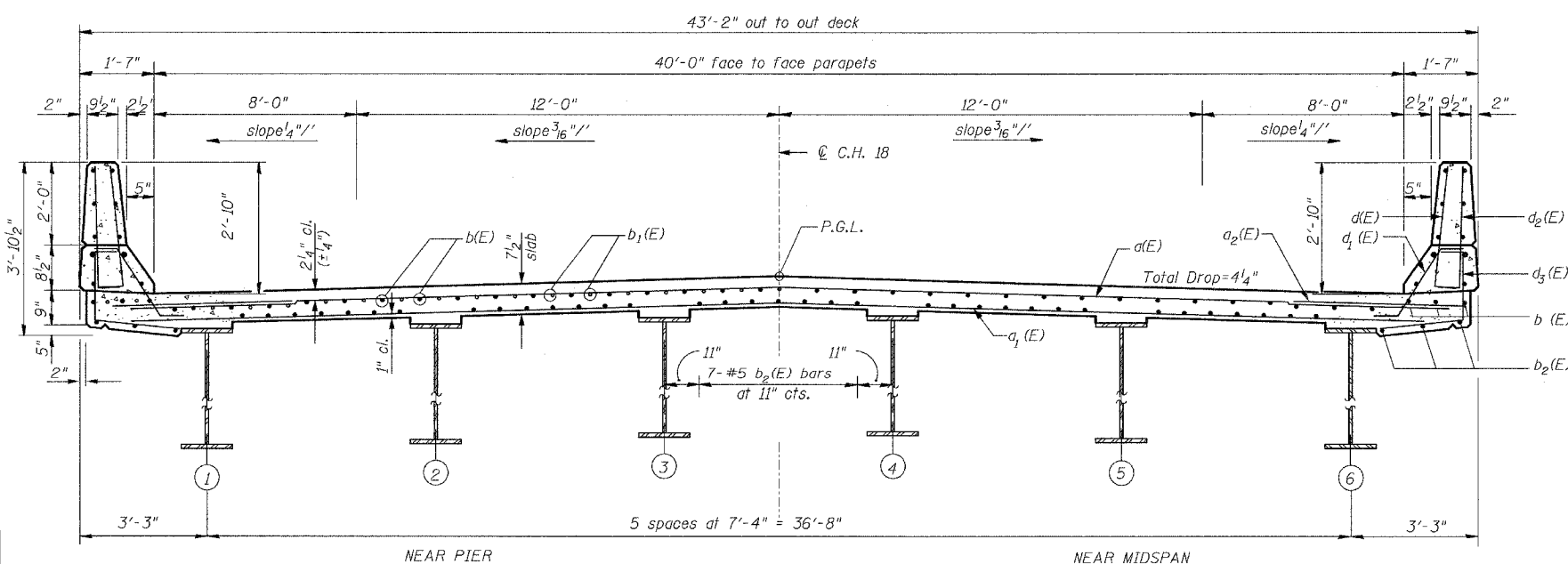

CROSS SECTION
(Looking Upstation)

MIN. BAR LAP
#5 Bar = 1'-8"
#6 Bar = 2'-0"

REVISIONS	
NAME	DATE

ILLINOIS DEPARTMENT OF TRANSPORTATION
DECK DETAILS
 CH 18 OVER US 45 AND CN/IC RR
 FAS 642 SECTION 99-00124-01-PV
 COLES COUNTY
 STA. 121+87.25 STR. No. 015-3400
 SCALE: DRAWN BY LMP
 DATE: 1-21-2004 CHECKED BY MJS

THE UPCHURCH GROUP
 HILLSIDE, IL. (708) 449-2321
 MATTOON, IL. (217) 235-3177

F.A.P. RTE.	SECTION	COUNTY	TOTAL SHEETS	SHEET NO.
642	99-00124-01-PV	COLES	157	91
STA.		TO STA.		
FED. ROAD DIST. NO.		ILLINOIS FED. AID PROJECT		

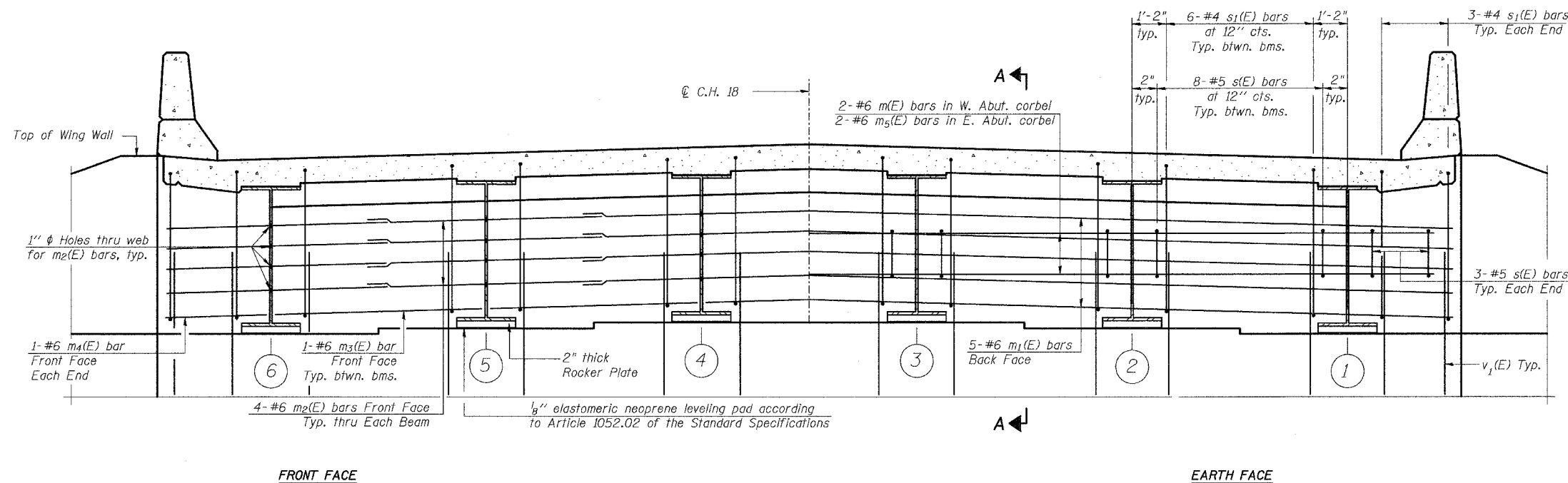

END DIAPHRAGM AT WEST ABUTMENT

(Looking West)
(East Abutment Similar)
(Dimensions are perpendicular to C.R. Roadway)

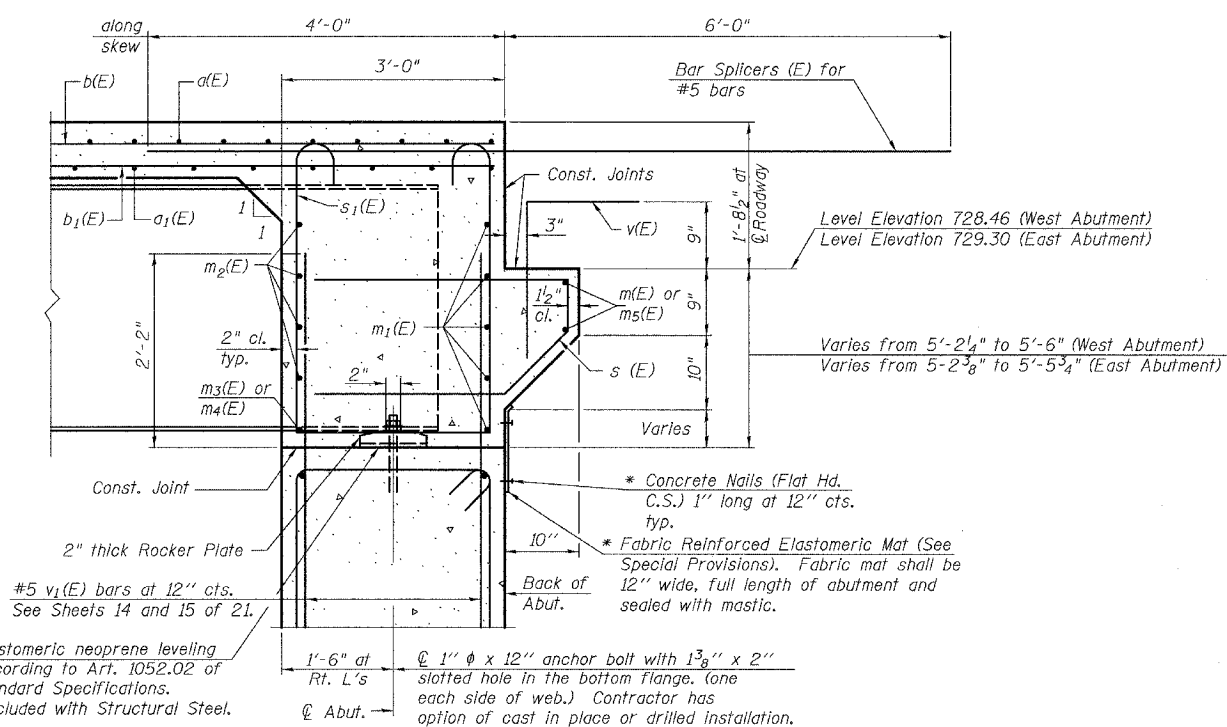

SECTION A-A

Dimensions at right angles to abutment, except as shown.
* Cost Included with Concrete Structures.

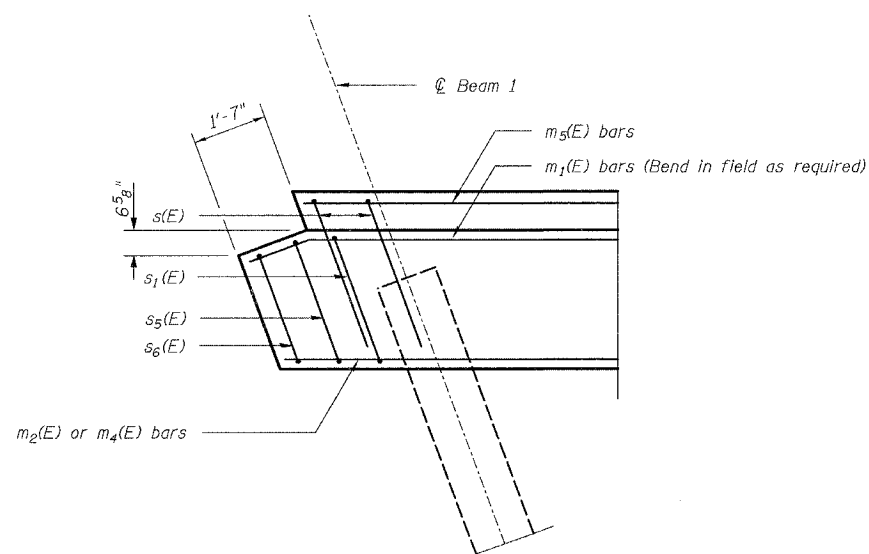

PLAN VIEW

(North Corner of Diaphragm at East Abutment)

Notes:
Reinforcement bars designated (E) shall be epoxy coated.

Reinforcement bars in diaphragm are billed with superstructure on Sheet 9 of 21.

Concrete in diaphragm is included with Concrete Superstructure on Sheet 9 of 21.

For details of bars s(E), s1(E), s5(E) & s6(E), see Sheet 9 of 21.

The s(E) and s1(E) bars shall be placed parallel to the beams. Spacing for these bars shall be at right angles to the beams.

Work this sheet with Sheets 7 and 9 of 21.

Pour Abutment Diaphragm monolithically with Slab.

See Sheet 18 of 21 for Bar Splicer details.

See Sheet 17 of 21 for Anchor Bolt details.

MIN. BAR LAP

#6 bar = 2'-9"

REVISIONS	
NAME	DATE

ILLINOIS DEPARTMENT OF TRANSPORTATION
END DIAPHRAGM DETAILS
CH 18 OVER US 45 AND CN/IC RR
FAS 642 SECTION 99-00124-01-PV
COLES COUNTY
STA. 121+87.25 STR. No. 015-3400

SCALE: DRAWN BY AGG
DATE: 1-21-2004 CHECKED BY MJS

THE UPCHURCH GROUP

HILLSIDE, IL. (708) 449-2321
MATTOON, IL. (217) 236-3177

F.A.P. RTE.	SECTION	COUNTY	TOTAL SHEETS	SHEET NO.
642	99-00124-01-PV	COLES	157	92
STA.	TO STA.			
FED. ROAD DIST. NO.	ILLINOIS	FED. AID PROJECT		

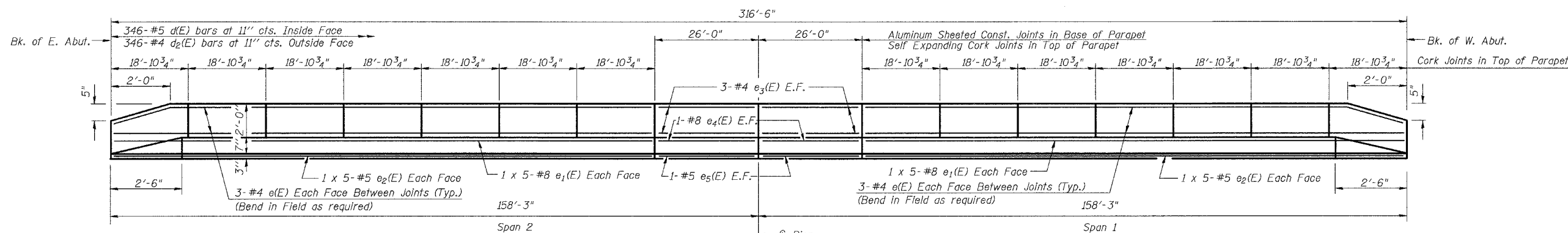

INSIDE ELEVATION OF PARAPET (Looking South)

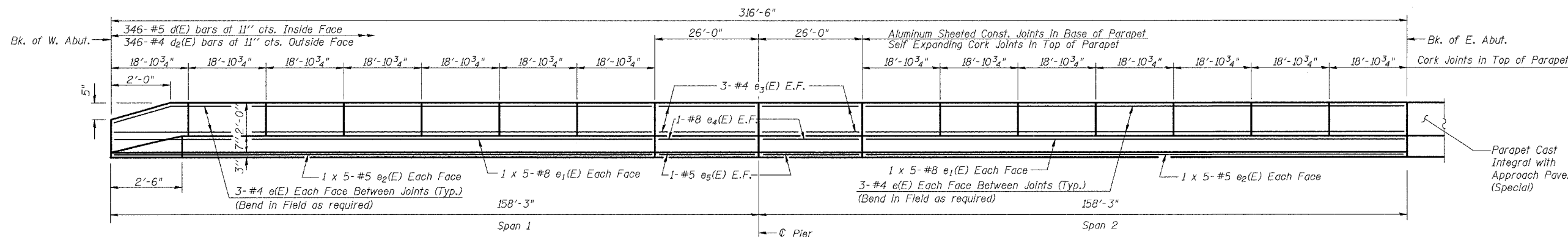

INSIDE ELEVATION OF PARAPET (Looking North)

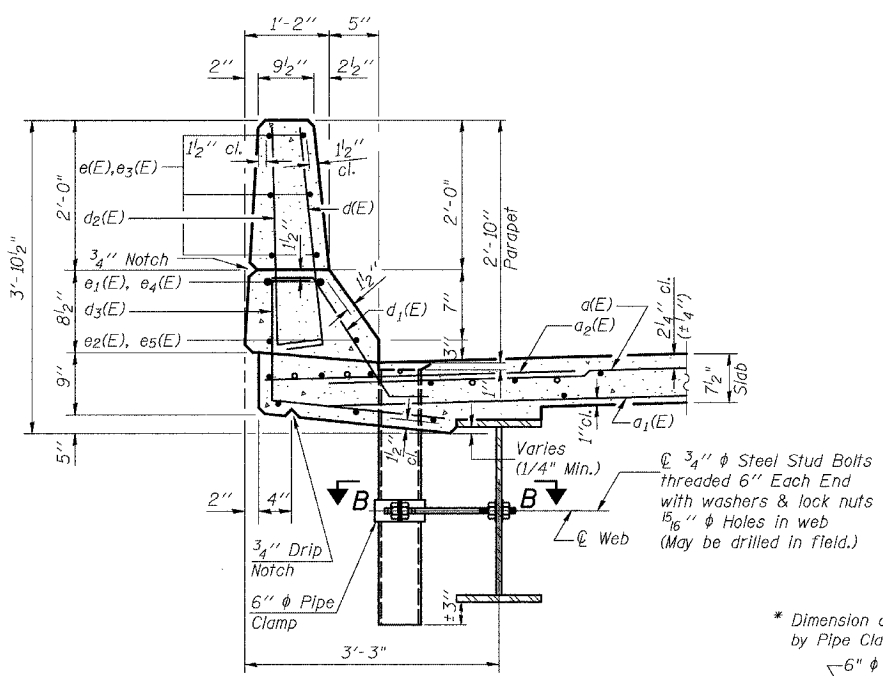

SECTION THRU PARAPET

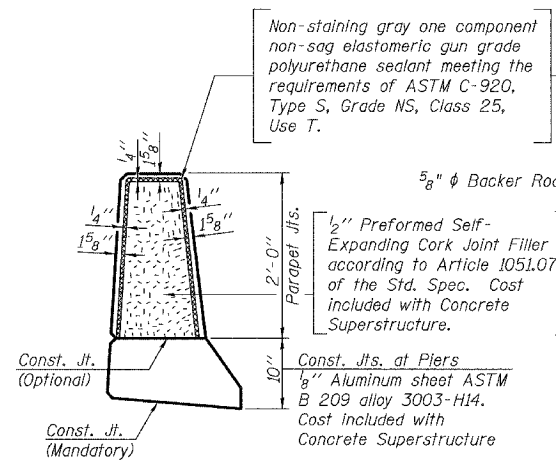

PARAPET JOINT DETAILS

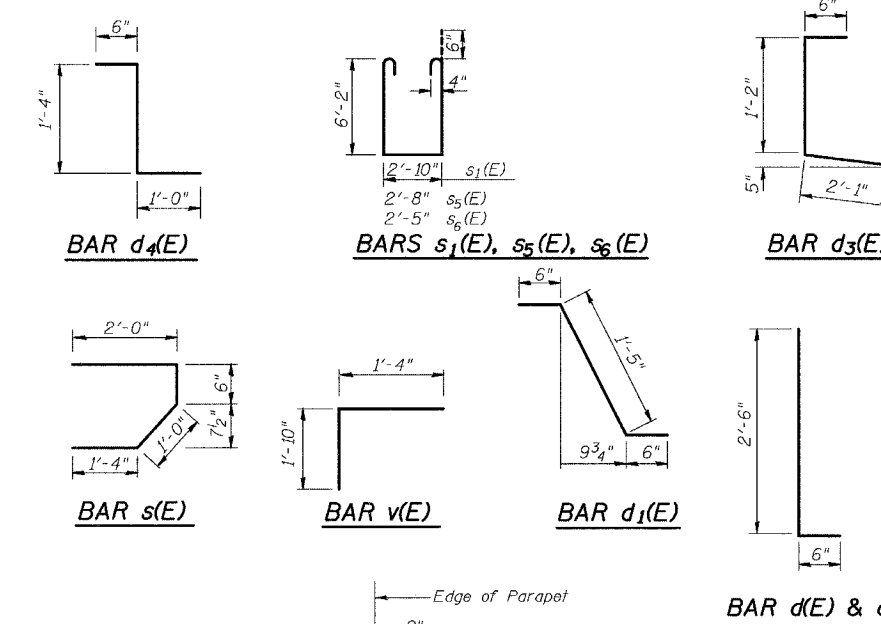

SUPERSTRUCTURE BILL OF MATERIAL

Bar	No.	Size	Length	Shape
a(E)	584	#5	42'-6"	—
a1(E)	422	#5	41'-8"	—
a2(E)	582	#6	4'-6"	—
a3(E)	4	#5	43'-9"	—
b(E)	414	#5	36'-8"	—
b1(E)	129	#6	32'-0"	—
b2(E)	328	#5	41'-0"	—
c(E)	692	#5	3'-0"	—
c1(E)	683	#5	2'-5"	—
c2(E)	692	#4	3'-0"	—
c3(E)	692	#4	3'-9"	—
c4(E)	9	#5	2'-10"	—
e(E)	168	#4	18'-6"	—
e1(E)	40	#8	29'-2"	—
e2(E)	40	#5	27'-9"	—
e3(E)	24	#4	25'-8"	—
e4(E)	8	#8	25'-8"	—
e5(E)	8	#5	25'-8"	—
m(E)	2	#6	44'-0"	—
m1(E)	10	#6	45'-8"	—
m2(E)	48	#6	10'-0"	—
m3(E)	10	#6	7'-6"	—
m4(E)	4	#6	3'-0"	—
m5(E)	2	#6	43'-3"	—
s(E)	91	#5	4'-10"	—
s1(E)	70	#4	16'-2"	—
s2(E)	1	#4	16'-0"	—
s3(E)	1	#4	15'-9"	—
v(E)	82	#5	3'-2"	—
Reinforcement Bars, Epoxy Coated	Pound		102,270	
Concrete Superstructure	Cu. Yds.		486.80	
Floor Drains	Each		8	

Reinforcement bars designated (E) shall be epoxy coated.
Bars indicated thus 1 x 5-#5 etc. indicates 1 line of bars with 5 lengths per line.
Work this Sheet with Sheets 7 and 8 of 21.

MIN. BAR LAP PARAPET

- #4 Bars = 1'-4"
- #5 Bars = 1'-8"
- #8 Bars = 3'-5"

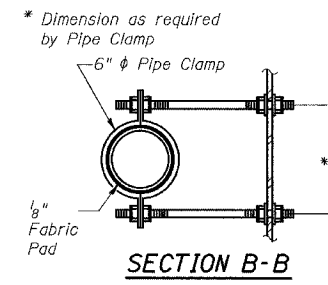

SECTION B-B

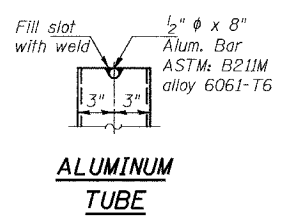

ALUMINUM TUBE

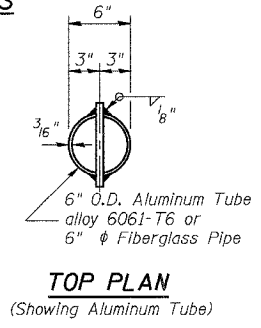

TOP PLAN (Showing Aluminum Tube)

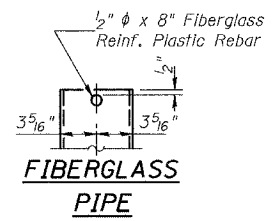

FIBERGLASS PIPE

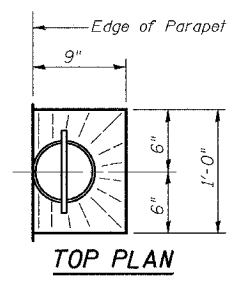

TOP PLAN

REVISIONS	
NAME	DATE

ILLINOIS DEPARTMENT OF TRANSPORTATION
SUPERSTRUCTURE DETAILS
CH 18 OVER US 45 AND CN/IC RR
FAS 642 SECTION 99-00124-01-PV
COLES COUNTY
STA. 121+87.25 STR. No. 015-3400

SCALE: DATE: 6/21/05

DRAWN BY LMP
CHECKED BY MJS

THE UPCHURCH GROUP
HILLSIDE, IL. (708) 449-2821
MATTOON, IL. (217) 285-8177

S-2-D 10-31-02

F.A.P. RTE.	SECTION	COUNTY	TOTAL SHEETS	SHEET NO.
642	99-00124-01-PV	COLES	157	93
STA.		TO STA.		
FED. ROAD DIST. NO.	ILLINOIS	FED. AID PROJECT		

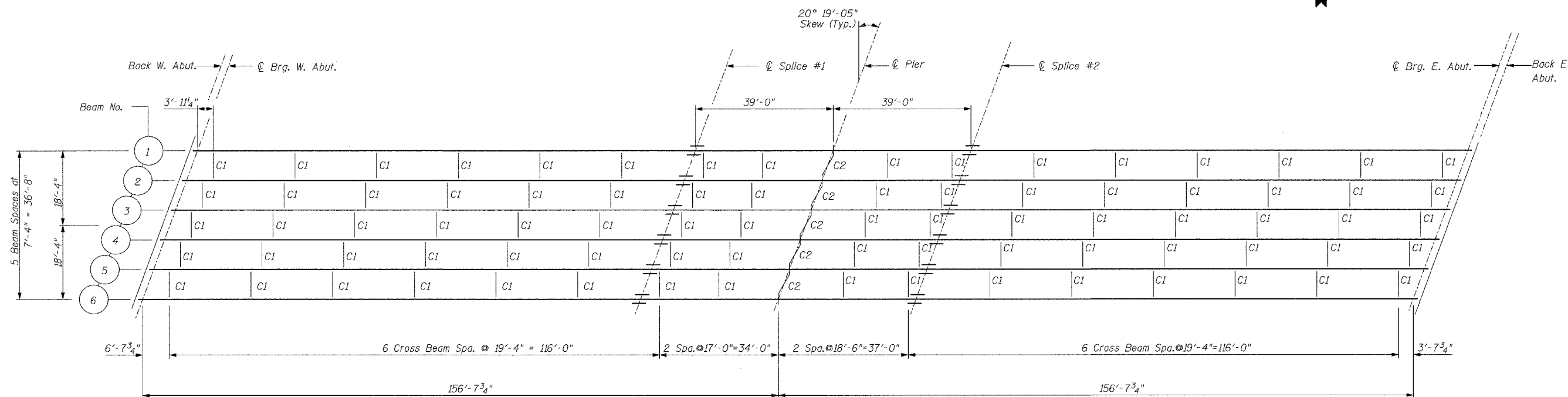

FRAMING PLAN

		0.4 Sp. 1 & 0.6 Sp. 2	Pier
I_s	(in ⁴)	46969	89952
I_c (n)	(in ⁴)	110449	
I_c (3n)	(in ⁴)	80101	
S_s	(in ³)	1432	2448
S_c (n)	(in ³)	1957	
S_c (3n)	(in ³)	1774	
Z	(in ³)		
ϕ	(K/ft.)	0.92	1.53
$M\ell$	(K)	1510	4612
$s\ell$	(K/ft.)	0.48	
$Ms\ell$	(K)	858	
$M\ell$	(K)	1430	1439
M (Imp)	(K)	254	255
$s_3(M\ell + I)$	(K)	2807	2823
Ma	(K)	6728	9674
Mu	(K)	9768	
$f_s\ell$ non-comp (k.s.i.)		12.65	22.61
$f_s\ell$ (comp)	(k.s.i.)	5.80	
$f_s s_3 (\ell + I)$	(k.s.i.)	17.21	13.84
f_s (Overload)	(k.s.i.)	35.66	36.45
f_s (Total)	(k.s.i.)		47.39
VR	(K)	63.5	

		Abut.	Pier
$R\ell$	(k)	82.4	286.7
$R\ell$	(k)	49.4	98.5
Imp	(k)	8.8	17.5
R (Total)	(k)	140.6	402.7

I_s and S_s are the moment of inertia and section modulus of the steel section used in computing f_s (Total & Overload).
 $I_c(n)$ and $S_c(n)$ are the moment of inertia and section modulus of the composite section used in computing stresses due to Live Load.
 $I_c(3n)$ and $S_c(3n)$ are the moment of inertia and section modulus of the composite section used in computing stresses due to superimposed dead loads. (see AASHTO 10.38)
 VR is the maximum Live Load + Impact shear range in span.
 Z is the plastic section modulus used to determine the fully plastic moments in the non-composite areas.
 Ma (Applied Moment) = $1.3[M\ell + Ms\ell + s_3(M\ell + M_{imp})]$.
 The plastic moment capacity (Mu) is computed according to ASSHTO 10.48.1 and 10.50.1.1.
 f_s (Overload) is the sum of the stresses due to $M\ell + Ms\ell + s_3(M\ell + M_{imp})$.
 f_s (Total) (Non-compact section) is the sum of the stresses due to $1.3[M\ell + Ms\ell + s_3(M\ell + M_{imp})]$.

- Notes:**
- For Girder and Splice Details see Sheet 11 of 21.
 - For Cross Frame Details see Sheet 12 of 21.

NAME	DATE

ILLINOIS DEPARTMENT OF TRANSPORTATION
FRAMING PLAN
 CH 18 OVER US 45 AND CN/IC RR
 FAS 642 SECTION 99-00124-01-PV
 COLES COUNTY
 STA. 121+87.25 STR. No. 015-3400

SCALE: DATE: 1-21-2004
 DRAWN BY: LMP
 CHECKED BY: MJS

THE UPCHURCH GROUP

HILLSIDE, IL. (708) 449-2321
 MATTOON, IL. (217) 235-3177

F.A.P. RTE.	SECTION	COUNTY	TOTAL SHEETS	SHEET NO.
642	99-00124-01-PV	COLES	157	94
STA.		TO STA.		
FED. ROAD DIST. NO.		ILLINOIS FED. AID PROJECT		

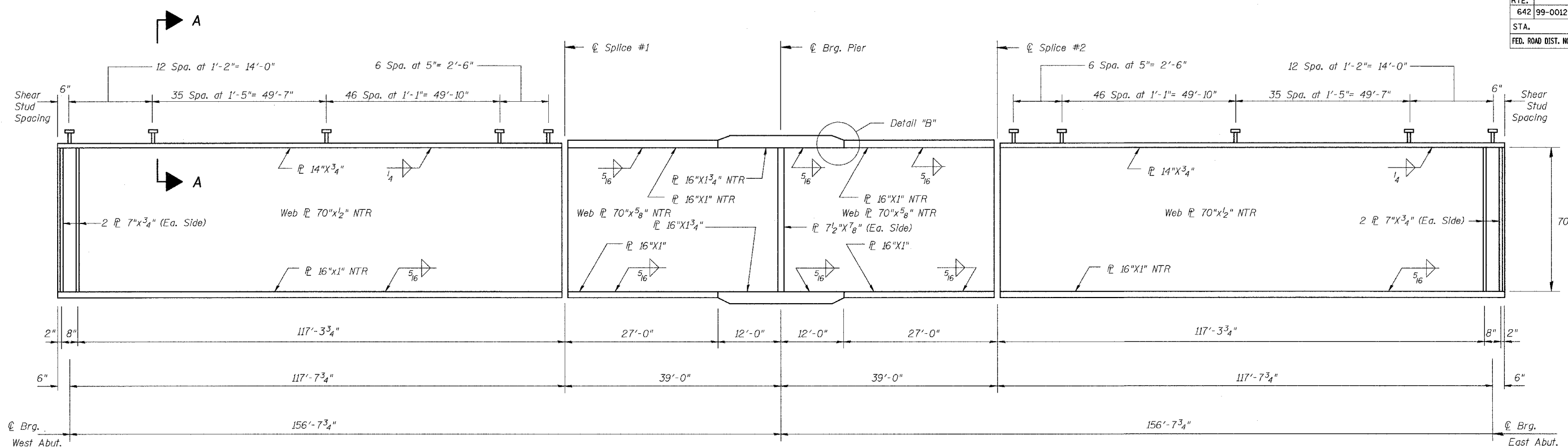

GIRDER ELEVATION
(All Plates shall be AASHTO M270 Grade 50)

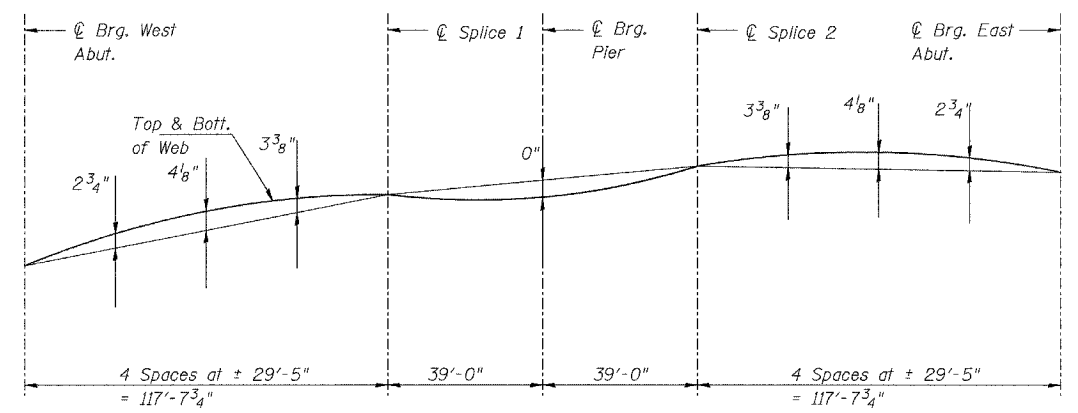
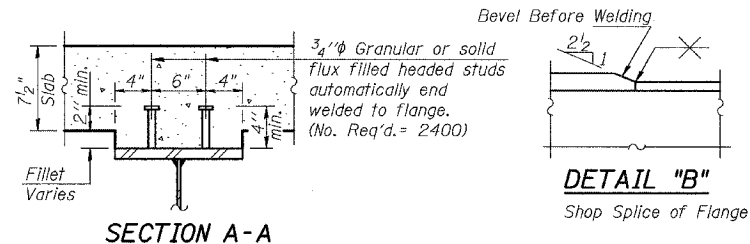

CAMBER DIAGRAM

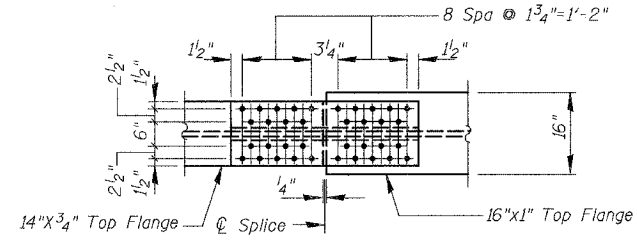

TOP PLAN

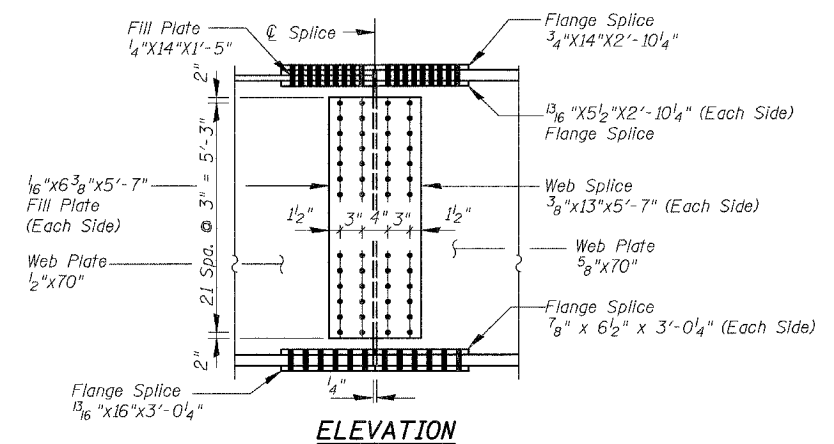

ELEVATION

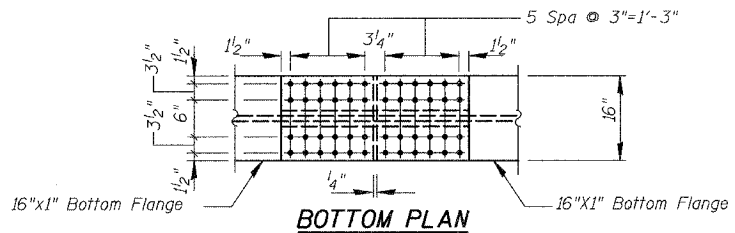

BOTTOM PLAN

FIELD SPLICE # 1 AND # 2 DETAILS

TOP OF WEB ELEVATIONS (FOR FABRICATION ONLY)						
GIRDER	1	2	3	4	5	6
BRG. W. ABUT.	729.17	729.29	729.39	729.36	729.22	729.05
SPLICE #1	729.80	729.93	730.04	730.03	729.90	729.74
BRG. PIER	729.89	730.03	730.14	730.14	730.01	729.85
SPLICE #2	729.98	730.13	730.24	730.24	730.12	729.97
BRG. E. ABUT.	729.90	730.05	730.18	730.19	730.08	729.96

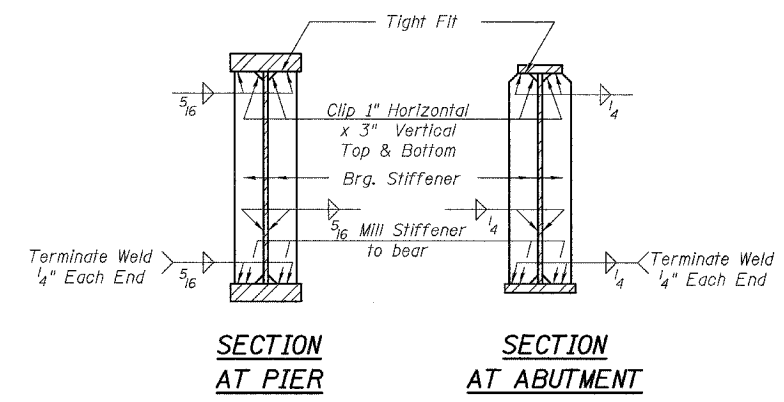

- Steel Designated with "NTR" shall conform to the requirements for Notch Toughness (Zone 2).
- All Splice Plates except Fill Plates shall conform to the requirements for Notch Toughness (Zone 2) and are AASHTO M270, Grade 50.
- Work this Sheet with Sheets 10 and 12 of 21

REVISIONS	
NAME	DATE

ILLINOIS DEPARTMENT OF TRANSPORTATION
GIRDER DETAILS
 CH 18 OVER US 45 AND CN/IC RR
 FAS 642 SECTION 99-00124-01-PV
 COLES COUNTY
 STA. 121+87.25 STR. No. 015-3400
 SCALE: DRAWN BY LP
 DATE: 01-21-2004 CHECKED BY

F.A.P. RTE.	SECTION	COUNTY	TOTAL SHEETS	SHEET NO.
642	99-00124-01-PV	COLES	157	95
STA.	TO STA.			
FED. ROAD DIST. NO.	ILLINOIS	FED. AID PROJECT		

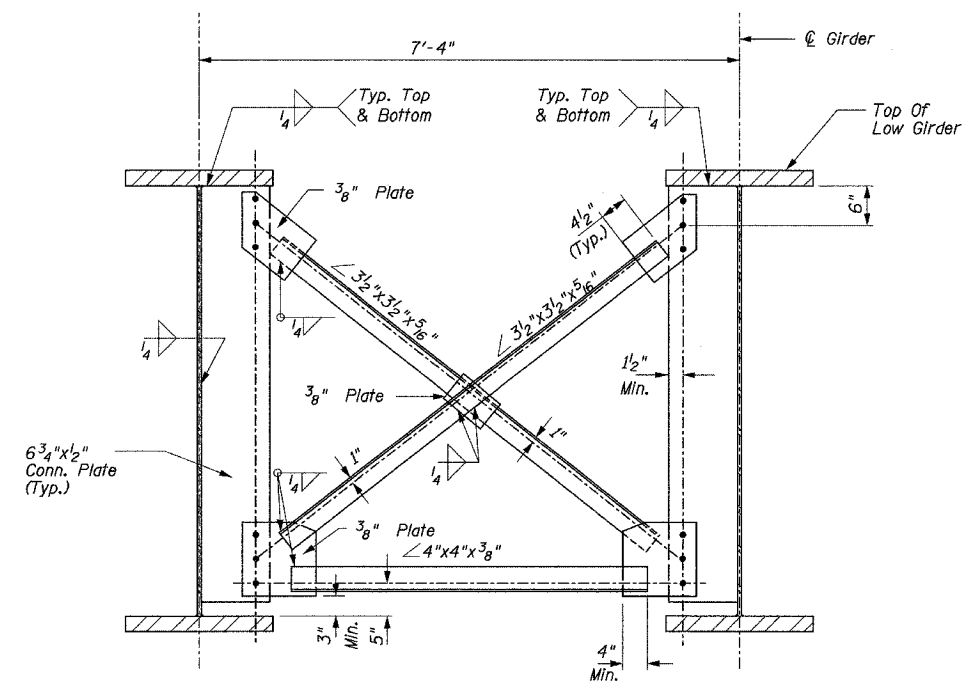

CROSS FRAME C-1
(80 Required)

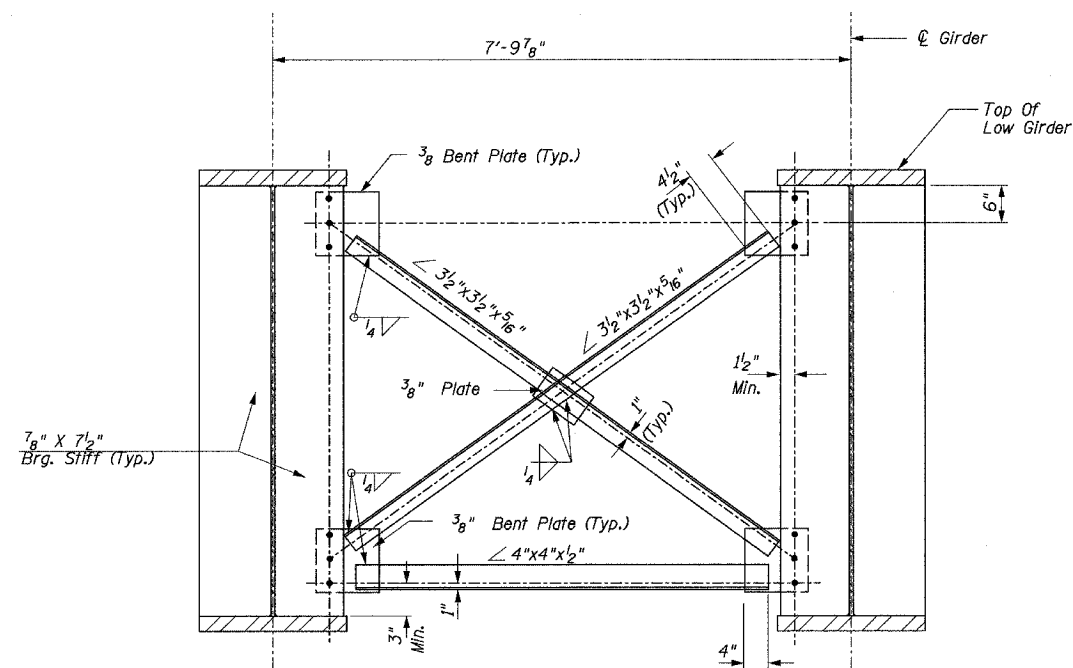

CROSS FRAME C-2
(5 Required)

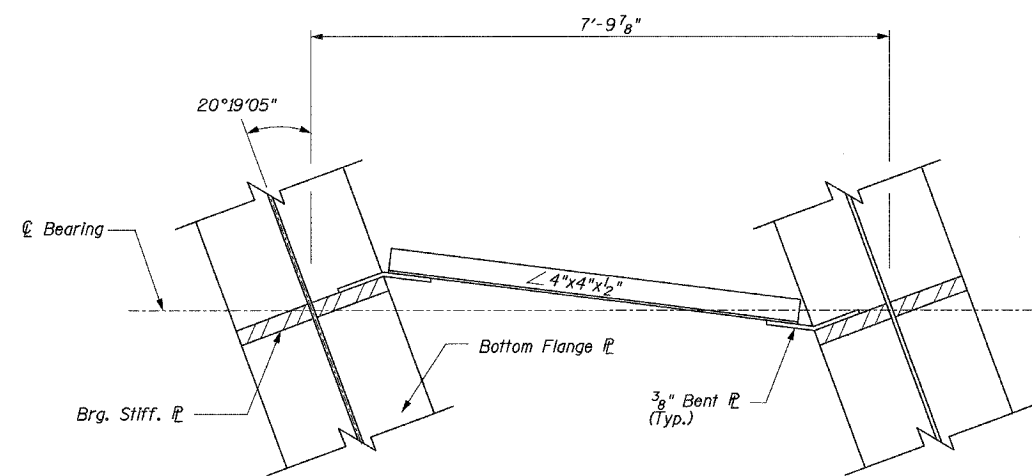

PARTIAL PLAN
CROSS FRAME C-2

Notes:

1. Work this sheet with Sheets 10 and 11 of 21.
2. Provide 1/16" ϕ holes for all 7/8" ϕ H.S. bolts.
3. Two hardened washers shall be required over all oversized holes.

THE UPCHURCH GROUP

HILLSIDE, IL. (708) 449-2321
MATTOON, IL. (217) 235-3177

REVISIONS	
NAME	DATE

ILLINOIS DEPARTMENT OF TRANSPORTATION
CROSS FRAME DETAILS
CH 18 OVER US 45 AND CN/IC RR
FAS 642 SECTION 99-00124-01-PV
COLES COUNTY
STA. 121+87.25 STR. No. 015-3400

SCALE: DATE: 1-21-2004 DRAWN BY LMP CHECKED BY MJS

F.A.P. RTE.	SECTION	COUNTY	TOTAL SHEETS	SHEET NO.
642	99-00124-01-PV	COLES	157	96
STA.		TO STA.		
FED. ROAD DIST. NO.	ILLINOIS	FED. AID PROJECT		

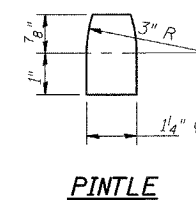
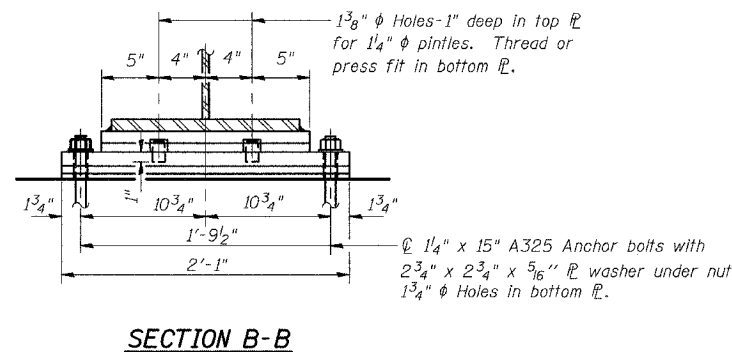
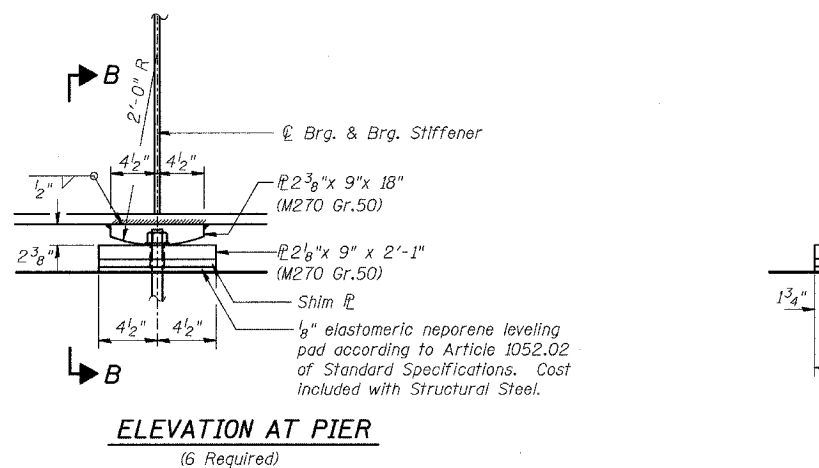
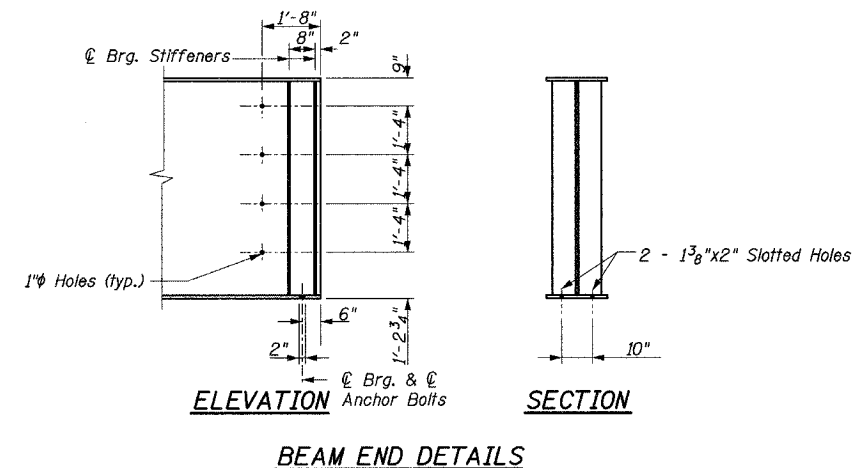
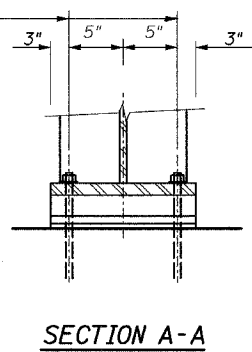
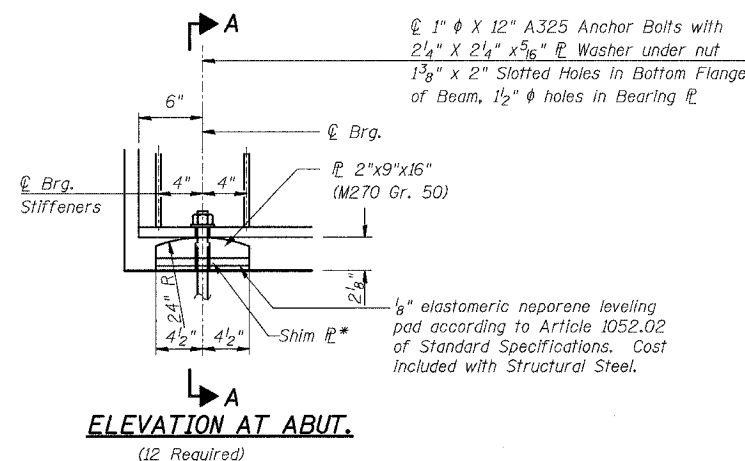

FIXED BEARING AT PIER

*** SHIM \varnothing REQUIRED IN ADDITION TO THE TWO $\frac{1}{8}$ " ADJUSTING SHIMS**

Location	Beam No.	Shim \varnothing Thickness (in.)
West Abutment	Beam 3	$\frac{3}{8}$ "
East Abutment	Beam 4	$\frac{1}{8}$ "

Notes: Anchor bolts at fixed bearings may be built into the masonry.
See sheet 17 of 21 for Anchor Bolt installation.

THE UPCHURCH GROUP

HILLSIDE, IL. (708) 449-2821
MATTOON, IL. (217) 235-3177

REVISIONS	
NAME	DATE

ILLINOIS DEPARTMENT OF TRANSPORTATION
BEARING DETAILS
 CH 18 OVER US 45 AND CN/IC RR
 FAS 642 SECTION 99-00124-01-PV
 COLES COUNTY
 STA. 121+87.25 STR. No. 015-3400

SCALE: DATE: 1-21-2004

DRAWN BY LMP
CHECKED BY MJS

F.A.P. NO.	SECTION	COUNTY	TOTAL SHEETS	SHEET NO.
642	99-00124-01-PV	COLES	157	97
STA.	TO STA.			
FED. ROAD DIST. NO.	ILLINOIS	FED. AID PROJECT		

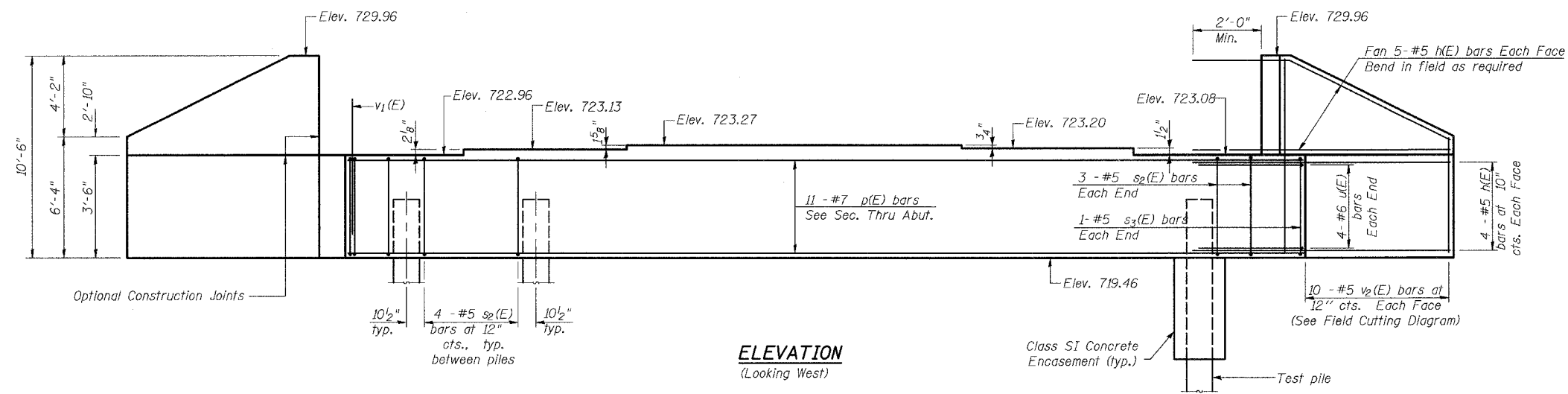

ELEVATION
(Looking West)

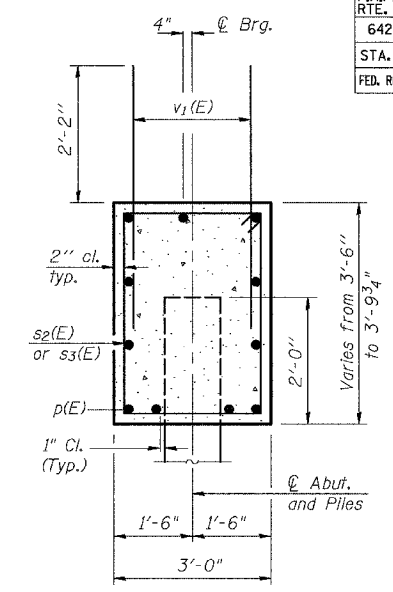

SEC. THRU ABUT.

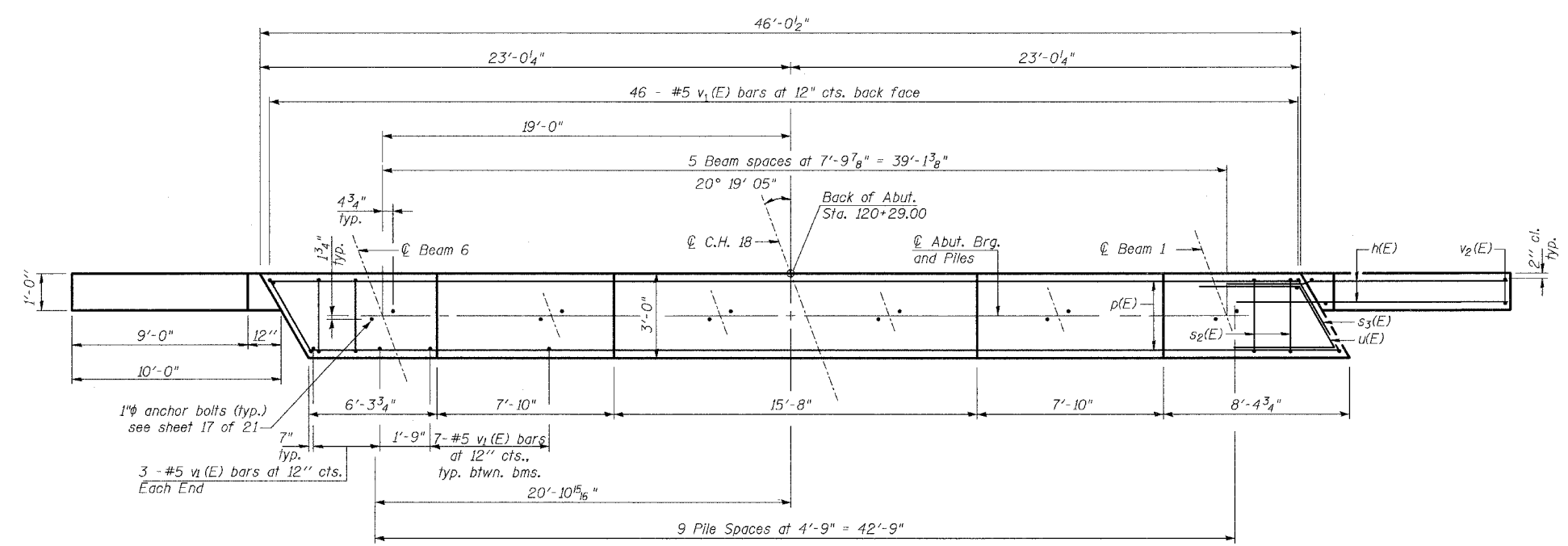

PLAN

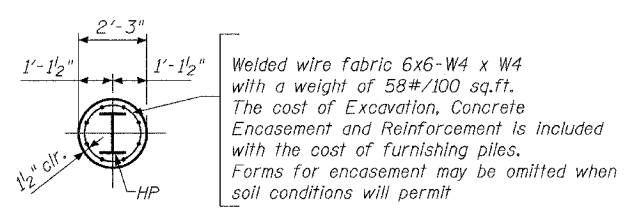

SECTION A-A

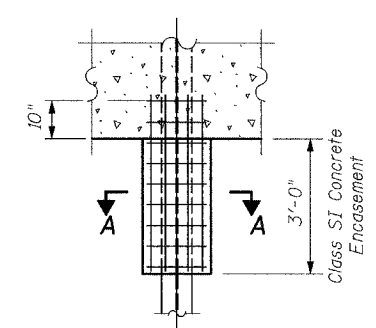

PILE ENCASEMENT DETAIL

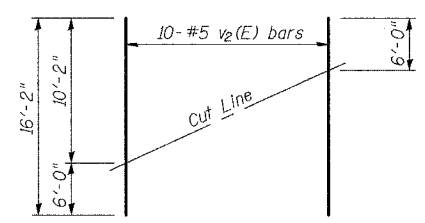

FIELD CUTTING DIAGRAM

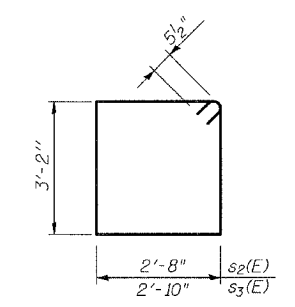

BARS s2(E) & s3(E)

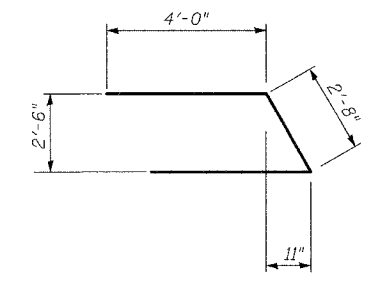

BAR u(E)

PILE DATA

Type	Steel HP14 X 89
No. Required	9+1 Test Pile **
Capacity	55T *
Est. Length	68'
* Drive to 83 Ton Bearing	
** Test Pile 55 Ton Capacity and Driven to 95 Ton Bearing	

BILL OF MATERIAL

Bar	No.	Size	Length	Shape
h(E)	36	#5	12'-6"	—
p(E)	11	#7	45'-8"	—
s2(E)	42	#5	12'-7"	□
s3(E)	2	#5	12'-11"	□
u(E)	8	#6	10'-8"	└
v1(E)	87	#5	4'-4"	—
v2(E)	20	#5	16'-2"	—
Concrete Structures		Cu. Yd.	25.3	
Reinforcement Bars, Epoxy Coated		Pound	2935	
Structure Excavation		Cu. Yd.	271	
Furnishing Steel Piles HP14x89		Ft.	612	
Driving Steel Piles HP14x89		Ft.	612	
Test Pile Steel HP14x89		Each	1	

NOTES:
 Pour steps monolithically with cap.
 Reinforcement bars designated (E) shall be epoxy coated.
 Space reinforcement to miss anchor bolts.

REVISIONS

NAME	DATE

ILLINOIS DEPARTMENT OF TRANSPORTATION
WEST ABUTMENT DETAILS
 CH 18 OVER US 45 AND CN/IC RR
 FAS 642 SECTION 99-00124-01-PV
 COLES COUNTY
 STA. 121+87.25 STR. No. 015-3400
 SCALE: DRAWN BY LMP
 DATE: 1-21-2004 CHECKED BY MJS

THE UPCHURCH GROUP
 HILLSIDE, IL. (708) 449-2321
 MATTOON, IL. (217) 236-3177

AI-L 9-01-03

F.A.P. RTE.	SECTION	COUNTY	TOTAL SHEETS	SHEET NO.
642	99-00124-01-PV	COLES	157	98
STA.	TO STA.			
FED. ROAD DIST. NO.	ILLINOIS	FED. AID PROJECT		

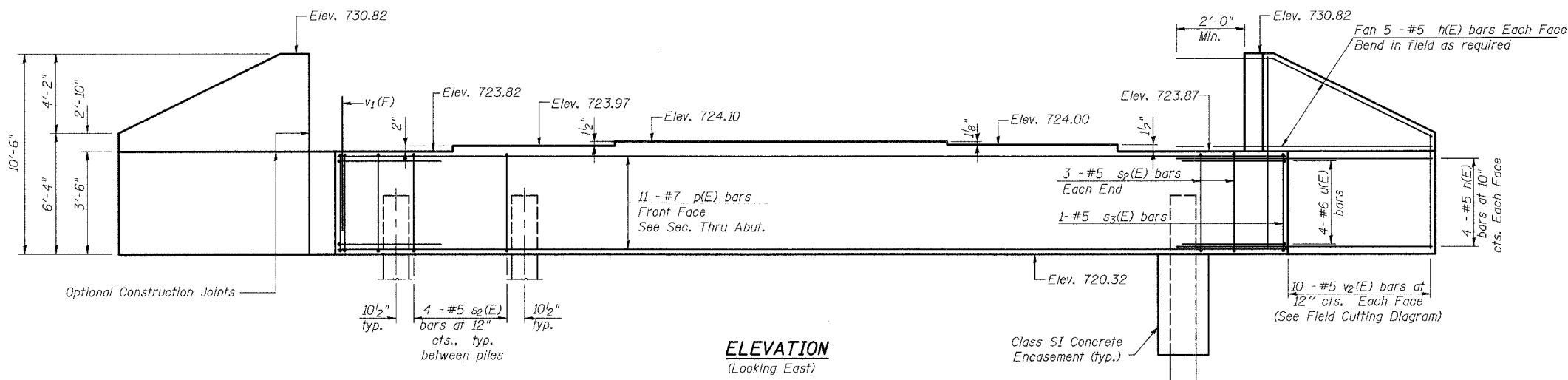

ELEVATION
(Looking East)

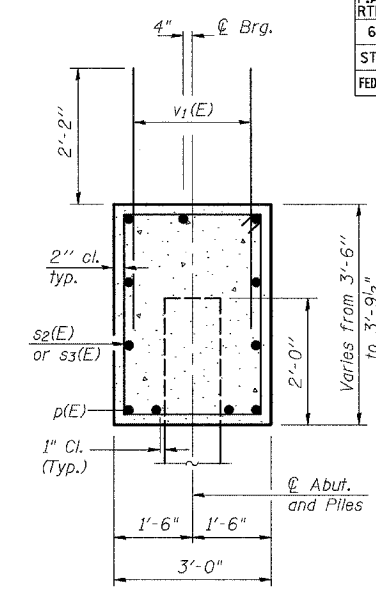

SEC. THRU ABUT.

PILE DATA

Type	Steel HP14 X 89
No. Required	10
Capacity	55T *
Est. Length	80'
* Drive to 83 Ton Bearing	

BILL OF MATERIAL

Bar	No.	Size	Length	Shape
h(E)	36	#5	12'-6"	—
p(E)	11	#7	45'-8"	—
s2(E)	42	#5	12'-7"	□
s3(E)	2	#5	12'-11"	□
u(E)	8	#6	10'-8"	⌒
v1(E)	87	#5	4'-4"	—
v2(E)	20	#5	16'-2"	—
Concrete Structures		Cu. Yd.	25.2	
Reinforcement Bars, Epoxy Coated		Pound	2935	
Structure Excavation		Cu. Yd.	271	
Furnishing Steel Piles HP14x89		Ft.	800	
Driving Steel Piles		Ft.	800	

NOTES:

Pour steps monolithically with cap.
Reinforcement bars designated (E) shall be epoxy coated.
Space reinforcement to miss anchor bolts.

REVISIONS	
NAME	DATE

ILLINOIS DEPARTMENT OF TRANSPORTATION
EAST ABUTMENT DETAILS
CH 18 OVER US 45 AND CN/IC RR
FAS 642 SECTION 99-00124-01-PV
COLES COUNTY
STA. 121+87.25 STR. No. 015-3400
SCALE: DRAWN BY LMP
DATE: 1-21-2004 CHECKED BY MJS

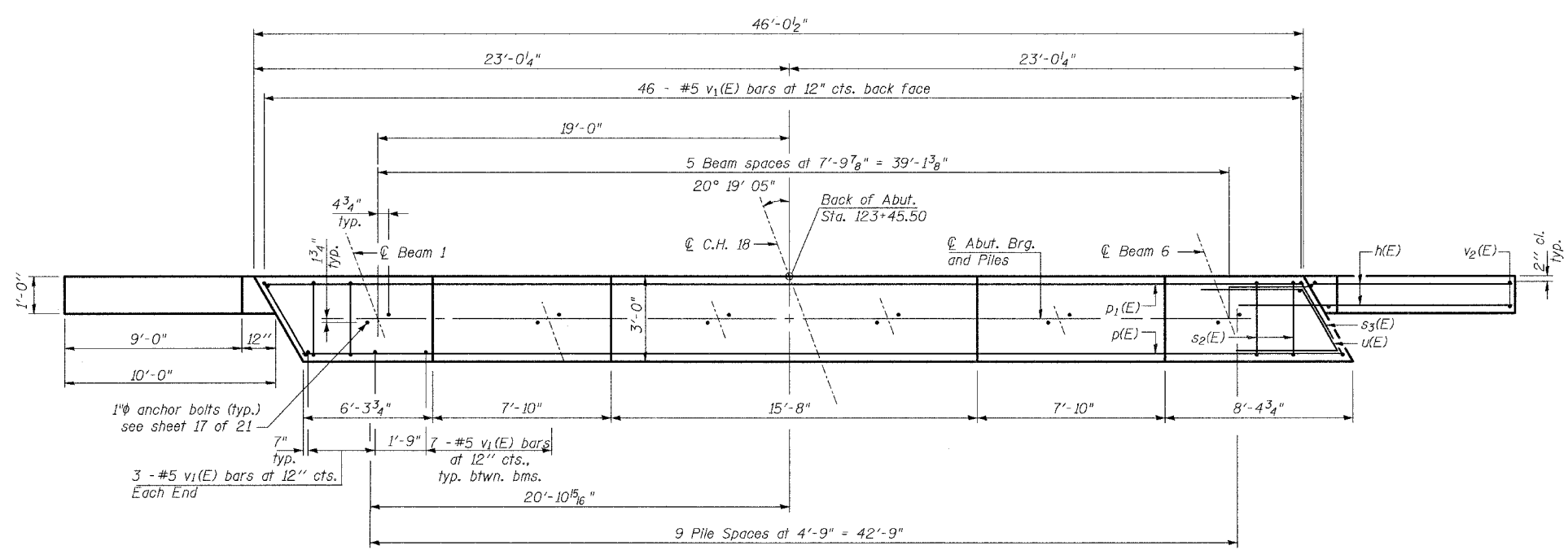

PLAN

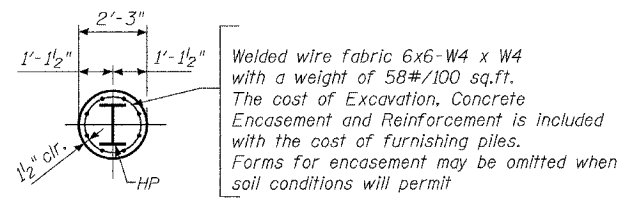

SECTION A-A

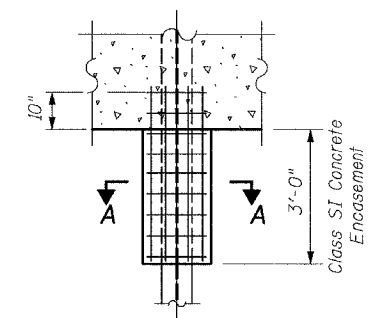

PILE ENCASUREMENT DETAIL

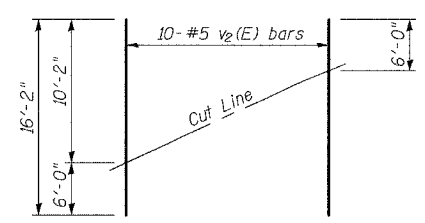

FIELD CUTTING DIAGRAM

Order v2(E) full length. Cut as shown and use remainder of bars in opposite face.

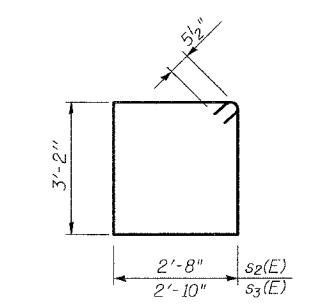

BARS s2(E), s3(E) & s4(E)

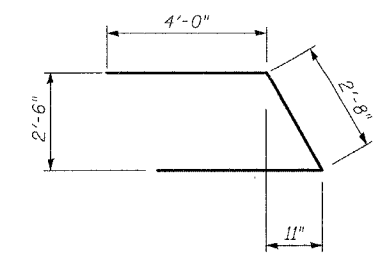

BAR u(E)

THE UPCHURCH GROUP
HILLSIDE, IL. (708) 449-2321
MATTOON, IL. (217) 235-3177

AI-L 9-01-03

F.A.P. RTE.	SECTION	COUNTY	TOTAL SHEETS	SHEET NO.
642	99-00124-01-PV	COLES	157	99
STA.		TO STA.		
FED. ROAD DIST. NO.		ILLINOIS FED. AID PROJECT		

- NOTES:
1. Pour steps monolithically with cap.
 2. Reinforcement bars designated (E) shall be epoxy coated.
 3. Space reinforcement to miss anchor bolts.

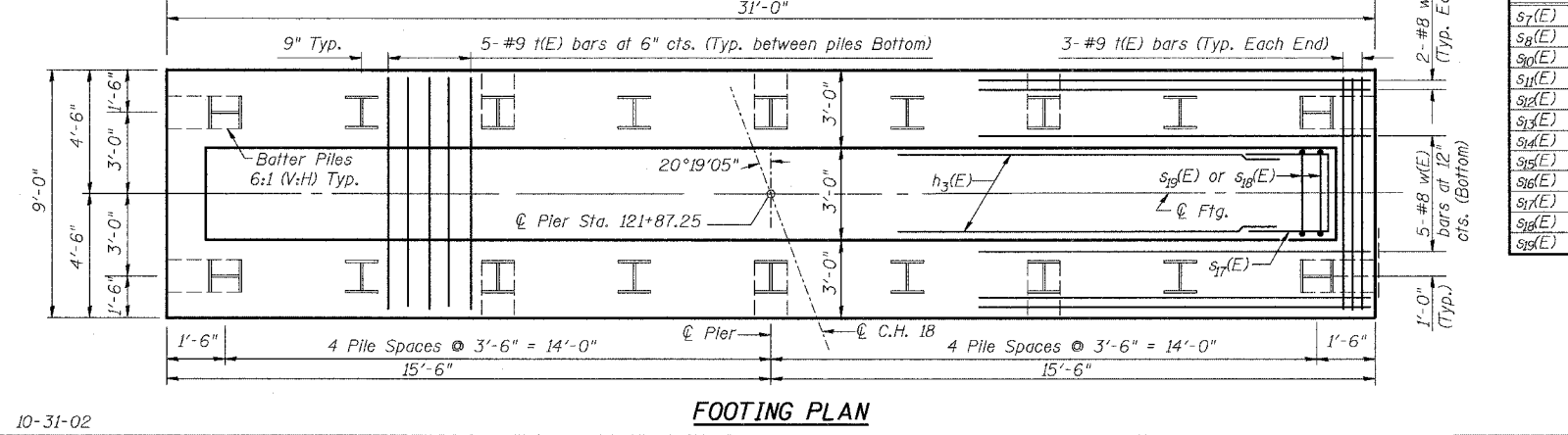
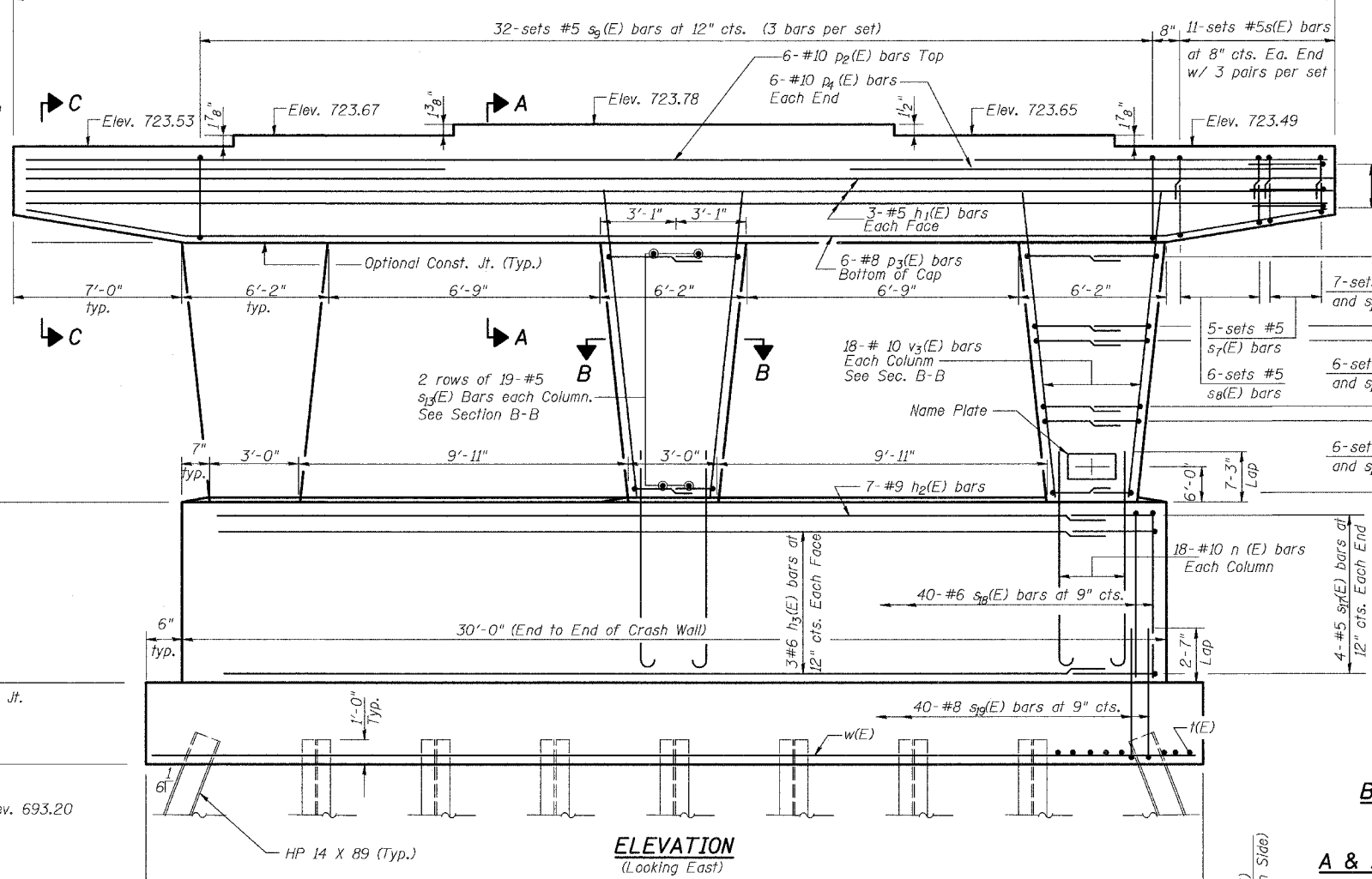
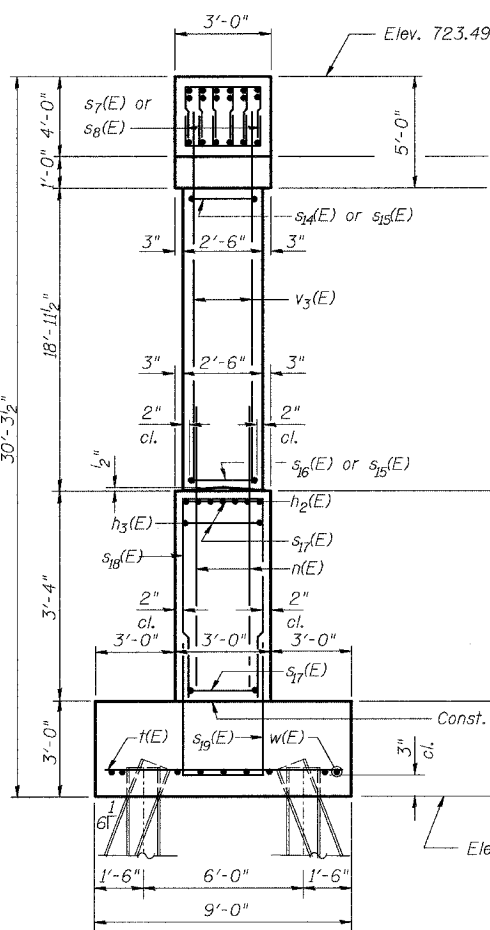
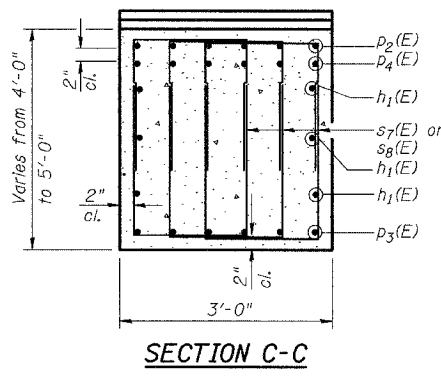
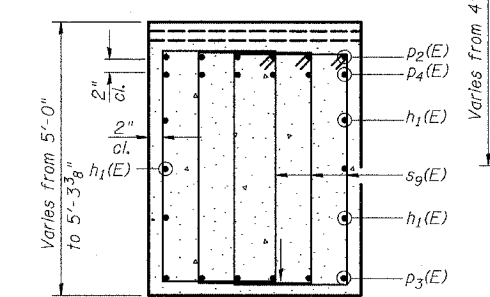
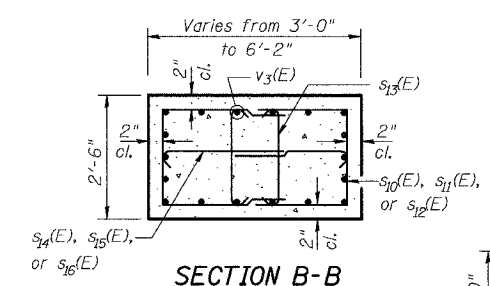
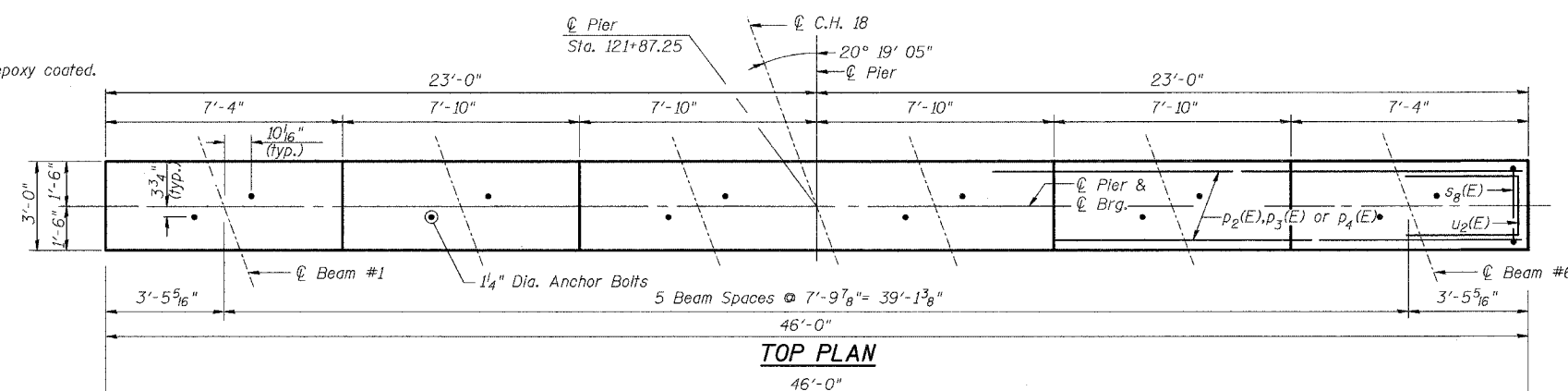

BILL OF MATERIAL

Bar	No.	Size	Length	Shape
h1(E)	6	5	45'-8"	
h2(E)	7	9	29'-8"	
h3(E)	6	6	29'-8"	
n(E)	54	10	12'-1"	
p2(E)	6	10	45'-8"	
p3(E)	6	8	45'-10"	
p4(E)	12	10	18'-0"	
s7(E)	60	5	8'-0"	
s8(E)	72	5	8'-6"	
s9(E)	96	5	13'-7"	
s10(E)	42	5	10'-2"	
s11(E)	36	5	9'-4"	
s12(E)	36	5	7'-6"	
s13(E)	114	5	3'-1"	
s14(E)	42	5	3'-2"	
s15(E)	36	5	4'-1"	
s16(E)	36	5	4'-6"	
s17(E)	8	5	6'-10"	
s18(E)	40	6	9'-0"	
s19(E)	40	8	13'-4"	
w(E)	46	9	8'-9"	
u2(E)	8	6	7'-8"	
v3(E)	54	10	22'-6"	
w(E)	9	8	30'-9"	
Structure Excavation		Cu. Yd.	75.3	
Concrete Structures		Cu. Yd.	91.9	
Reinforcement Bars, Epoxy Coated		Pound	20,765	
Furnishing Steel Piles HP14x89		Ft.	1,275	
Driving Steel Piles HP14x89		Ft.	1,275	
Test Pile Steel HP14x89		Each	1	

A & B DIMENSIONS

Bar	A	B
s7(E)	1'-8"	3'-2"
s8(E)	1'-8"	3'-5"
s9(E)	2'-2"	4'-0"
s10(E)	2'-2"	3'-7"
s11(E)	2'-2"	2'-8"
s12(E)	2'-2"	0'-5 1/2"
s13(E)	2'-8"	0'-5 1/2"
s14(E)	3'-7"	0'-5 1/2"
s15(E)	4'-0"	0'-5 1/2"
s16(E)	2'-6"	2'-2"
s17(E)	2'-8"	3'-2"
s18(E)	2'-8"	5'-4"

MIN. BAR LAP

- #5 Bars = 2'-2"
- #6 Bars = 2'-7"
- #10 Bars = 7'-3"

REVISIONS	
NAME	DATE

ILLINOIS DEPARTMENT OF TRANSPORTATION
PIER DETAILS
 CH 18 OVER US 45 AND CN/IC RR
 FAS 642 SECTION 99-00124-01-PV
 COLES COUNTY
 STA. 121+87.25 STR. No. 015-3400
 SCALE: DRAWN BY BJF
 DATE: 1-21-2003 CHECKED BY MJS

THE UPCHURCH GROUP
 HILLSIDE, IL. (708) 449-2321
 MATTOON, IL. (217) 235-3177

F.A.P. RTE.	SECTION	COUNTY	TOTAL SHEETS	SHEET NO.
642	99-00124-01-PV	COLES	157	100
STA.		TO STA.		
FED. ROAD DIST. NO.	ILLINOIS	FED. AID PROJECT		

The Illinois Coil-Lock Anchor Bolt is a proprietary item which is the property of the Illinois Department of Transportation. Use, reproduction or disclosure without express written permission is prohibited and protected under Federal copyright laws. The production and the fabrication of this bolt for use on highway projects in the State of Illinois shall be permitted and there shall be no incurred charges or fees to the manufacturer or the fabricator for producing or fabricating this bolt.

D	E	H	K	"d"
1"	1 1/8"	1 3/16"	1 3/4"	1/4"
1 1/4"	1 3/8"	1 1/16"	2"	3/8"
1 1/2"	1 5/8"	1 5/16"	2 1/8"	1/2"
2"	2 1/8"	1 13/16"	2 7/8"	1/2"
2 1/2"	2 5/8"	2 5/16"	3 3/8"	1"

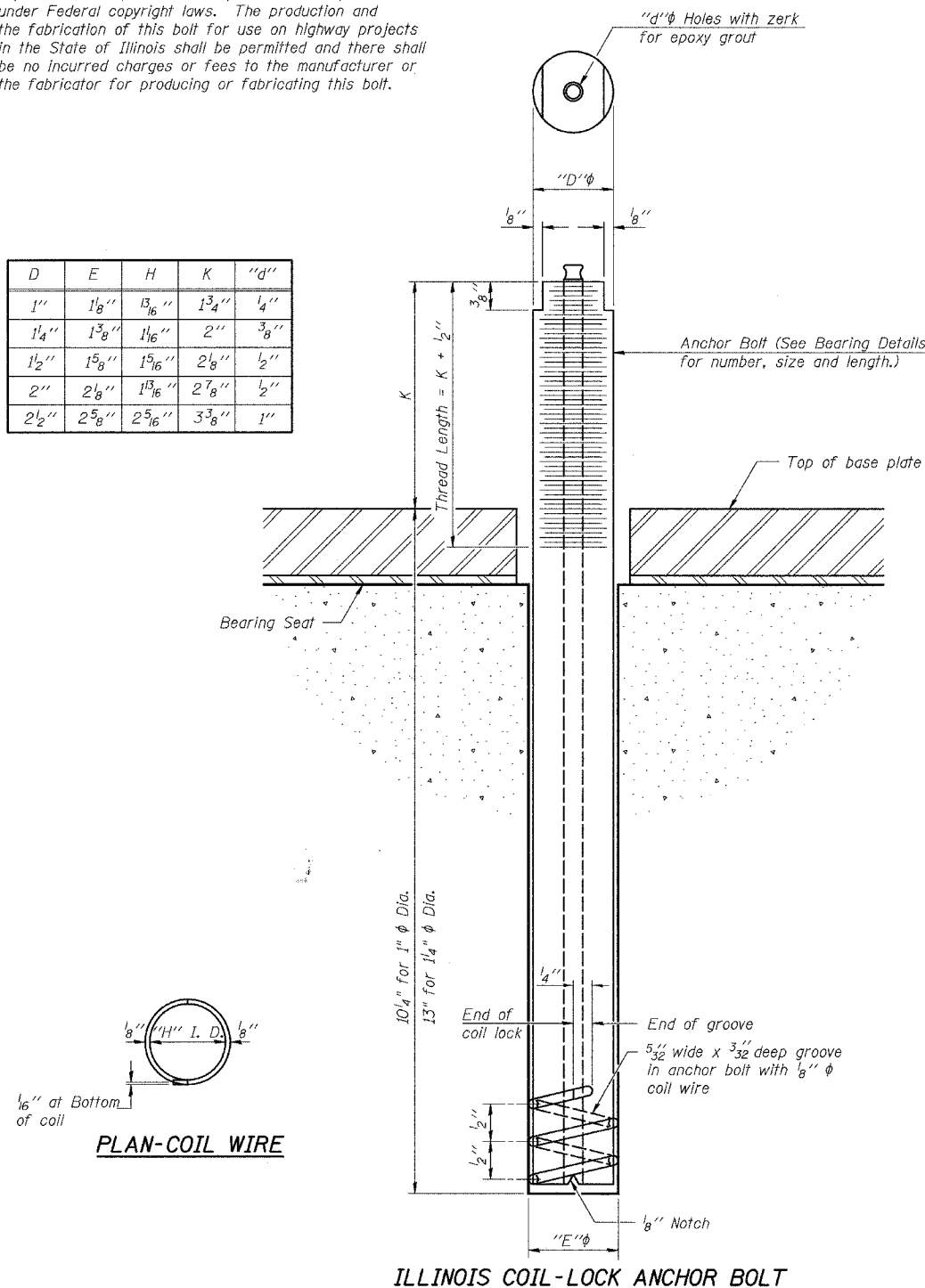

MATERIALS FOR ILLINOIS COIL-LOCK ANCHOR BOLT

The anchor bolt shall be fabricated from cold drawn or hot finished seamless carbon steel mechanical tubing conforming to ASTM A 519, Grade 1026, CW and supplied with hexagonal nuts and cut washers.
 The coil wire shall be made of any suitable soft steel wire.
 The finished anchor bolt shall be cleaned of rust and other foreign materials and wrapped or packaged to prevent contamination until they are installed.
 The epoxy grout shall be a two-component, epoxy resin bonding system conforming to ASTM C 881, Type I, Grade 1 and of a Class suitable for the temperature at installation.

INSTALLATION PROCEDURE for the ILLINOIS COIL-LOCK ANCHOR BOLT

1. With the coil wire in place, the bolt shall be inserted into the hole and turned clockwise to a snug fit in the hole. Nut and washer shall be placed on the bolt. The nut shall be tensioned until the steel base plates are held securely to the concrete bearing seat.
2. Epoxy grout shall be pumped through the zerk fitting with a pressure gun. Pumping shall continue until the epoxy overflows the hole around the bolt shank. After pumping is discontinued, excess epoxy shall be immediately wiped off.

ALTERNATE ANCHOR BOLTS

The Contractor may use, at his option, the capsule or the adhesive cartridge type anchor rods that have been previously tested and given a prior approval by the Department. The Contractor shall install these anchor rods in pre-drilled holes according to the manufacturer's recommendations and procedures.

- The capsule or the adhesive cartridge type anchor rods shall be a two part system composed of:
1. A threaded rod stud with nut and washer of the type specified.
 2. A sealed glass capsule or a sealed glass adhesive cartridge containing premeasured amounts of the adhesive chemical.

Location	Type
Abutment	A325
Pier	A325

ASTM F 1554 Grade 105, ASTM A 449 and AASHTO M 314 Grade 105 anchor bolts may be substituted for the anchor bolts shown above.

GENERAL NOTES

Holes in the masonry for anchor bolts shall be drilled through the base plates to the diameter and depth shown or according to the manufacturer's recommendation after beams or girders have been erected and adjusted.
 Prior to setting the bolts, the holes shall be dry and all dust and loose particles shall be removed by the use of compressed air or vacuuming.
 The anchor bolts, furnished and installed and including the epoxy grout or capsules shall not be paid for separately but shall be included in the unit bid price for Furnishing and Erecting Structural Steel.

THE UPCHURCH GROUP

HILLSIDE, IL. (708) 449-2321
 MATTOON, IL. (217) 235-3177

ABB-1 4-30-99

REVISIONS	
NAME	DATE

ILLINOIS DEPARTMENT OF TRANSPORTATION
ANCHOR BOLT DETAILS
 CH 18 OVER US 45 AND CN/IC RR
 FAS 642 SECTION 99-00124-01-PV
 COLES COUNTY
 STA. 121+87.25 STR. No. 015-3400

SCALE: DATE: 1-21-2004 DRAWN BY AGG CHECKED BY MJS

F.A.P. RTE.	SECTION	COUNTY	TOTAL SHEETS	SHEET NO.
642	99-00124-01-PV	COLES	157	101
STA.	TO STA.			
FED. ROAD DIST. NO.	ILLINOIS	FED. AID PROJECT		

NOTES

Bar splicer assemblies shall be of an approved type and shall develop in tension at least 125 percent of the yield strength of the lapped reinforcement bars.
 Splicer rods shall be of minimum 60 ksi yield strength, threaded or coiled full length.
 All reinforcement bars shall be lapped and tied to the splicer rods or dowel bars.
 Bar splicer assemblies shall be epoxy coated according to the requirements for reinforcement bars.
 Other systems of similar design may be submitted to the Engineer for approval. Approval shall be based on certified test results from an approved testing laboratory that the proposed bar splicer assembly satisfies the following requirements:

- ① Minimum Capacity = $1.25 \times f_y \times A_t$
(Tension in kips)
- ② Minimum *Pull-out Strength = $1.25 \times f_{sallow} \times A_t$
(Tension in kips)

Where f_y = Yield strength of lapped reinforcement bars in ksi.
 f_{sallow} = Allowable tensile stress in lapped reinforcement bars in ksi (Service Load)
 A_t = Tensile stress area of lapped reinforcement bars.
 * = 28 day concrete

Bar Size to be Spliced	Splicer Rod or Dowel Bar Length	Strength Requirements	
		Min. Capacity kips - tension	Min. Pull-Out Strength kips - tension
#4	1'-8"	14.7	5.9
#5	2'-0"	23.0	9.2
#6	2'-7"	33.1	13.3
#7	3'-5"	45.1	18.0
#8	4'-6"	58.9	23.6
#9	5'-9"	75.0	30.0
#10	7'-3"	95.0	38.0
#11	9'-0"	117.4	46.8

Bar splicer assemblies shall be according to Section 508 of the Standard Specifications, except as noted. The furnishing and installation of bar splicer assemblies will be measured and paid for at the contract unit price each for "BAR SPLICERS."

The diameter of this part is the same as the diameter of the bar spliced.

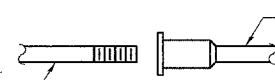

ROLLED THREAD DOWEL BAR



**** ONE PIECE**

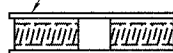
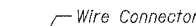

WELDED SECTIONS

BAR SPLICER ASSEMBLY ALTERNATIVES

** Heavy Hex Nuts conforming to ASTM A 563, Grade C, D or DH may be used.

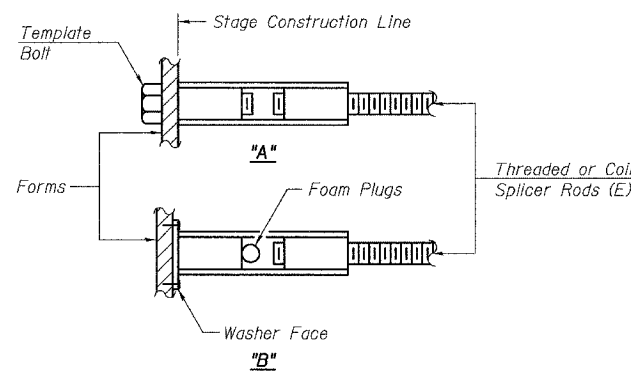

INSTALLATION AND SETTING METHODS

"A" : Set bar splicer assembly by means of a template bolt.
 "B" : Set bar splicer assembly by nailing to wood forms or cementing to steel forms.
 (E) : Indicates epoxy coating.

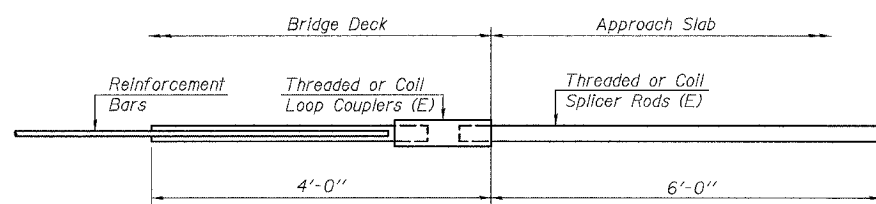

FOR INTEGRAL OR SEMI-INTEGRAL ABUTMENTS

Bar Splicer for #5 bar
Min. Capacity = 23.0 kips - tension
Min. Pull-out Strength = 9.2 kips - tension
No. Required = 80

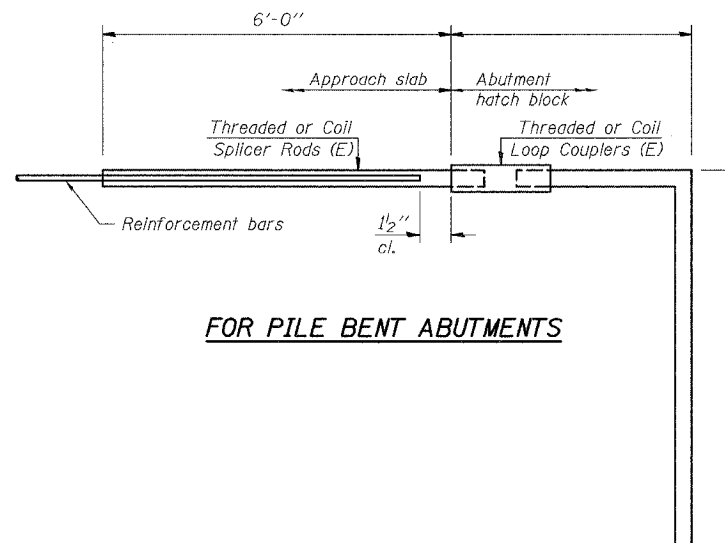

FOR PILE BENT ABUTMENTS

Bar Splicer for #5 bar
Min. Capacity = 23.0 kips - tension
Min. Pull-out Strength = 9.2 kips - tension
No. Required = NONE

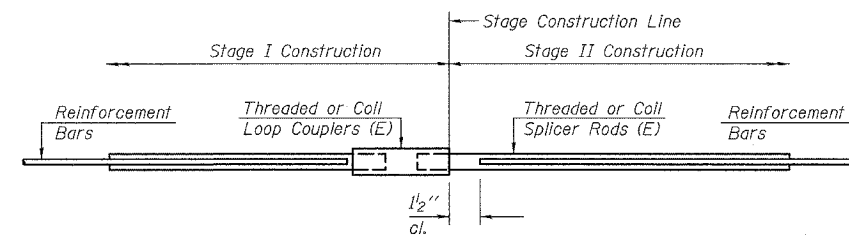

STANDARD

Bar Size	No. Assemblies Required	Location

BAR SPLICER ASSEMBLY DETAILS

REVISIONS	
NAME	DATE

ILLINOIS DEPARTMENT OF TRANSPORTATION
BAR SPLICER
 CH 18 OVER US 45 AND CN/IC RR
 FAS 642 SECTION 99-00124-01-PV
 COLES COUNTY
 STA. 121+87.25 STR. No. 015-3400
 SCALE: N.T.S. DRAWN BY AGG
 DATE: 1-21-2004 CHECKED BY MJS

THE UPCHURCH GROUP

HILLSIDE, IL. (708) 449-2321
 MATTOON, IL. (217) 235-3177

BSD-1 9-01-03

F.A.P. RTE.	SECTION	COUNTY	TOTAL SHEETS	SHEET NO.
642	99-00124-01-PV	COLES	157	104
STA.		TO STA.		
FED. ROAD DIST. NO.		ILLINOIS FED. AID PROJECT		



SOIL BORING LOG

Page 1 of 2

Date 11/25/02

ROUTE F.A.I. RTE 57 DESCRIPTION US 45 Grade Separation Structure LOGGED BY CNA
 SECTION 99-00124-00-PV LOCATION NW SEC. 6 TWP. 12N RNG. 8E 3rd PM
 COUNTY Coles DRILLING METHOD Hollow Stem Auger HAMMER TYPE Automatic

STRUCT. NO. Station	D E P T H ft	B L O W S (ft)	U C S Qu (tsf)	M O I S T (%)	Surface Water Elev. Stream Bed Elev. ft	D E P T H ft	B L O W S (ft)	U C S Qu (tsf)	M O I S T (%)	Groundwater Elev.: First Encounter Upon Completion After Hrs
BORING NO. <u>2 W. Abut.</u> Station <u>120+25</u> Offset <u>.00 ft. Lt.</u> Ground Surface Elev. <u>696.5</u> ft					Gray Sandy Clay Loam (continued)					
					674.5					
					Gray Silty Clay Loam					
			4				2			
			3	1.3	29		5	2.7	15	
		-5	5	B			4	B		
Brown Sandy Clay Loam		3								
		4	2.9	17						
		5	B							
Brown Sandy Loam Till		2				3				
		5	2.7	14		6	2.9			
		7	B			8	E			
Gray Sandy Clay Loam		2								
		4	3.9	12						
		6	B							
Gray Sandy Clay Loam (Til)		2				1				
		4	3.1	13		3	1.2	13		
		6	B			3	B			
Gray Sandy Clay Loam (Til)										
Gray Sandy Clay Loam (Til)		1				6				
		3	2.5	13		12	10.7	10		
		5	B			16	B			

The Unconfined Compressive Strength (UCS) Failure Mode is indicated by (B-Bulge, S-Shear, P-Penetrometer)
 The SPT (N value) is the sum of the last two blow values in each sampling zone (AASHTO T206)

BBS 137 (3/01)



SOIL BORING LOG

Page 2 of 2

Date 11/25/02

ROUTE F.A.I. RTE 57 DESCRIPTION US 45 Grade Separation Structure LOGGED BY CNA
 SECTION 99-00124-00-PV LOCATION NW SEC. 6 TWP. 12N RNG. 8E 3rd PM
 COUNTY Coles DRILLING METHOD Hollow Stem Auger HAMMER TYPE Automatic

STRUCT. NO. Station	D E P T H ft	B L O W S (ft)	U C S Qu (tsf)	M O I S T (%)	Surface Water Elev. Stream Bed Elev. ft	D E P T H ft	B L O W S (ft)	U C S Qu (tsf)	M O I S T (%)	Groundwater Elev.: First Encounter Upon Completion After Hrs
BORING NO. <u>2 W. Abut.</u> Station <u>120+25</u> Offset <u>0.0 ft. Lt.</u> Ground Surface Elev. <u>696.5</u> ft					Gray Sandy Clay Loam (Till) (continued)					
					634.5					
					Gray Silty Clay					
			3				4			
			5	2.6	13		8	2.8	18	
		-45	7	B			12	S		
Gray Fine Sand & Silt & Dark Brown Silty Clay (Organic)		2								
		4								
		10								
Gray Clay Loam		5								
		9								
		10								
Gray Clay Loam		2								
		3	2.5	23						
		4	B							

The Unconfined Compressive Strength (UCS) Failure Mode is indicated by (B-Bulge, S-Shear, P-Penetrometer)
 The SPT (N value) is the sum of the last two blow values in each sampling zone (AASHTO T206)

BBS 137 (3/01)

THE UPCHURCH GROUP

HILLSIDE, IL. (708) 449-2321
 MATTOON, IL. (217) 235-8177

REVISIONS	
NAME	DATE

ILLINOIS DEPARTMENT OF TRANSPORTATION
 SOIL BORINGS - 3
 CH 18 OVER US 45 AND CN/IC RR
 FAS 642 SECTION 99-00124-01-PV
 COLES COUNTY
 STA. 121+87.25 STR. No. 015-3400
 SCALE: N.T.S. DRAWN BY JAU
 DATE: 1-21-2004 CHECKED BY MJS

F.A.P. RTE.	SECTION	COUNTY	TOTAL SHEETS	SHEET NO.
642	99-00124-01-PV	COLES	157	105
STA.	TO STA.			
FED. ROAD DIST. NO.	ILLINOIS	FED. AID PROJECT		

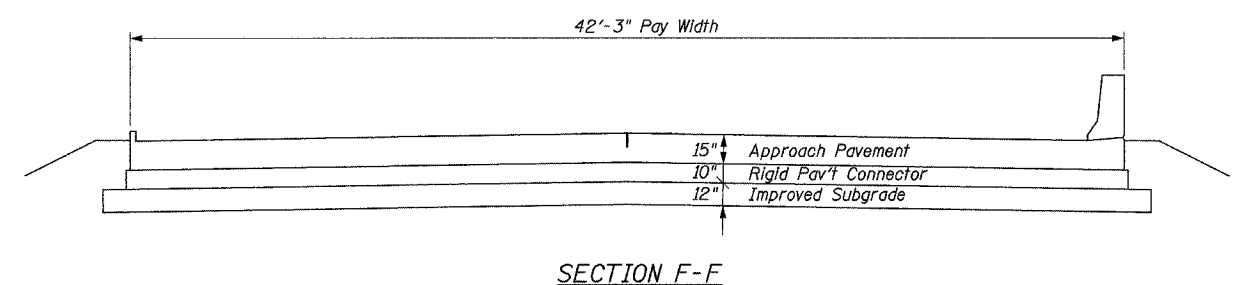
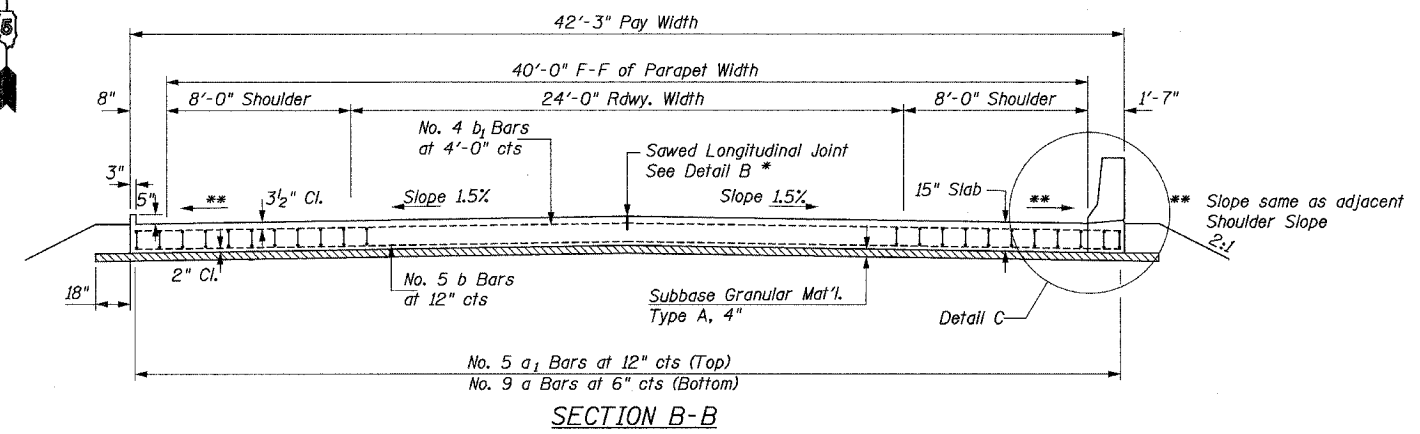
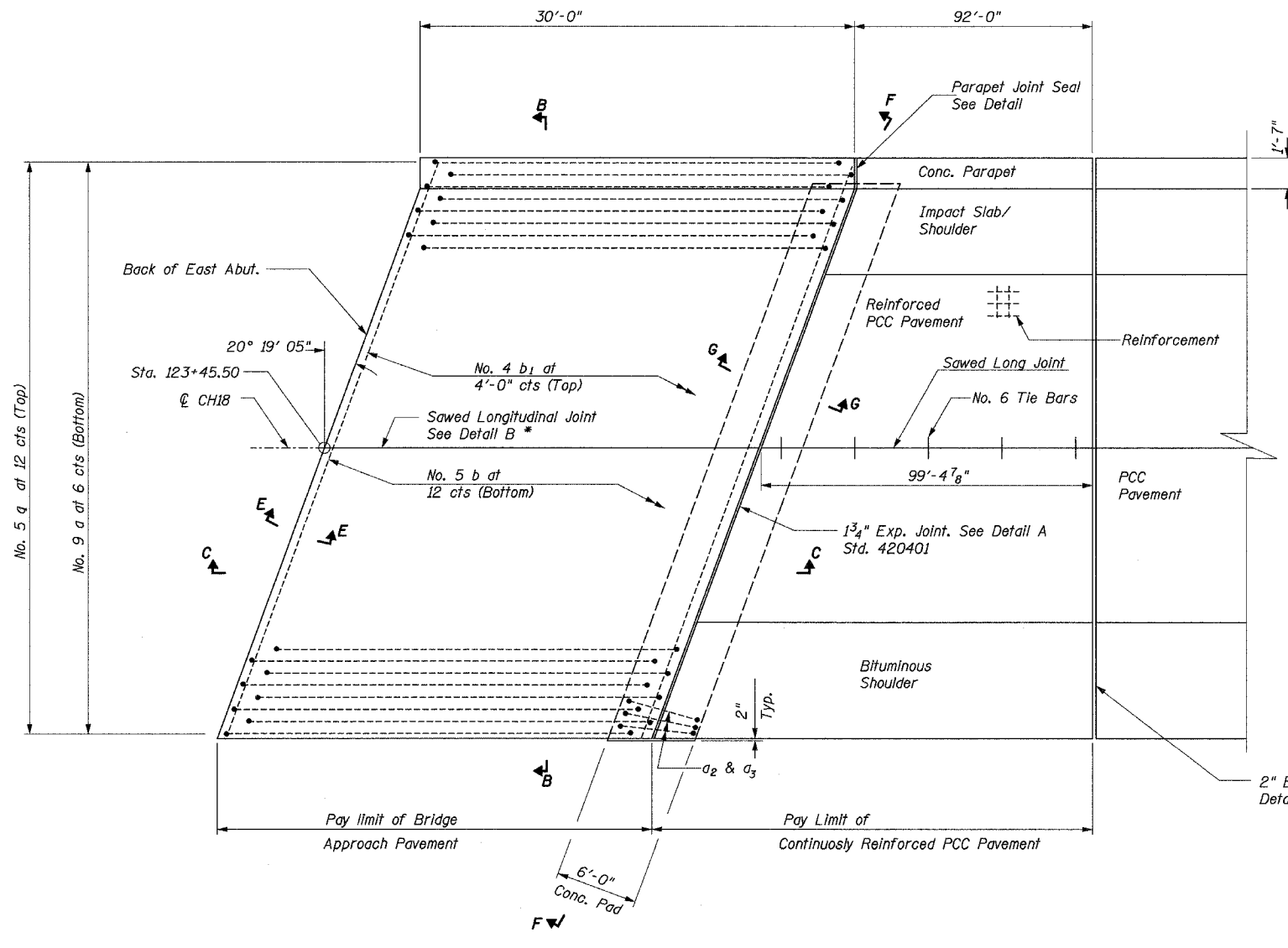

2" Exp. Joint as Detailed on Standard 4200001 * Saw CL or Lane Edge if poured two or more lane widths at a time

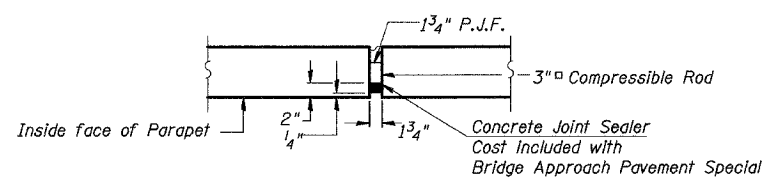

PARAPET JOINT SEAL (Cost of Joint Seal included with Concrete Superstructure)

BILL OF MATERIAL

Item	Unit	Qty
Bridge Approach Pavement Special	S.Y.	141

- Notes:**
- 1 Bridge Approach Pavement Special shall be constructed to the dimensions shown on this drawing.
 - 2 See "Bridge Approach Pavement" Std. 420401-01 for Section C-C, Section G-G-Rigid Pavement, Section E-E, Detail A, and Detail B.
 - 3 All Reinforcement bars shall be epoxy coated.
 - 4 See Std. 421001 for reinforcement details not shown.
 - 5 See Std 420001 for details of Joints not shown.
 - 6 All Parapet Corners chamfered 3/4"x3/4"

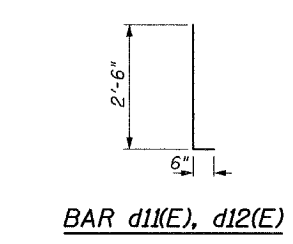
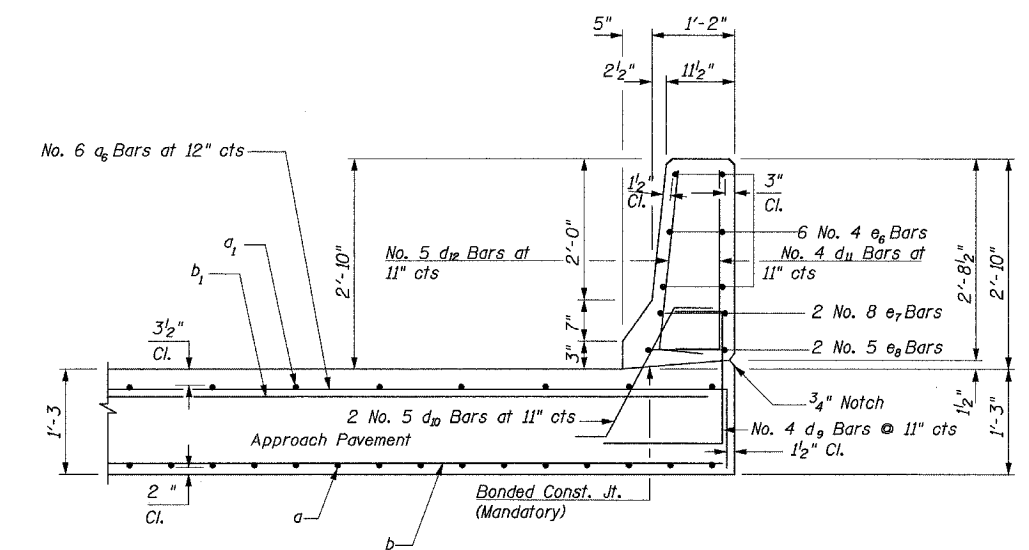

BAR d11(E), d12(E)

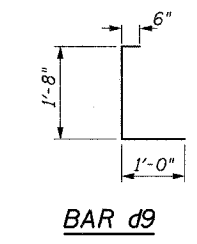

BAR d9

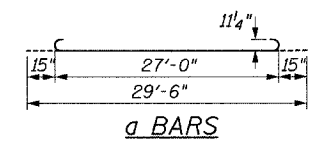

a BARS

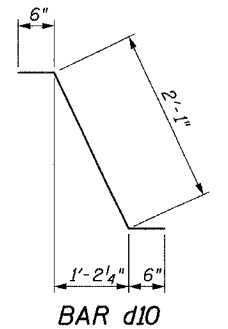

BAR d10

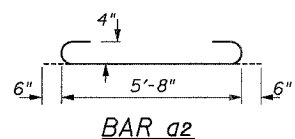

BAR a2

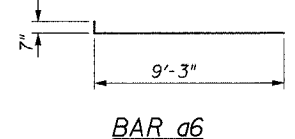

BAR a6

DESIGN STRESSES

f'c = 3500 psi
fy = 60000 psi
n = 8.5

REVISIONS	
NAME	DATE

ILLINOIS DEPARTMENT OF TRANSPORTATION
BRIDGE APPROACH PAVEMENT SPECIAL
CH 18 OVER US 45 AND CN/IC RR
FAS 642 SECTION 99-00124-01-PV
COLES COUNTY
STA. 121+87.25 STR. No. 015-3400
SCALE: DRAWN BY LMP
DATE: 1-21-2004 CHECKED BY MJS

THE UPCHURCH GROUP
HILLSIDE, IL. (708) 449-2321
MATTOON, IL. (217) 235-3177

DETAIL C

Benchwork: B.M. 600A Top Cap Bolt next to M in Mueller.
1st F.H. E of Inters. 620E/1000N,
S. Side of Rd. Elev. 699.58
Existing Structure: None

F.A.P. RTE.	SECTION	COUNTY	TOTAL SHEETS	SHEET NO.
642	99-00124-01-PV	COLES	157	106
STA.		TO STA.		
FED. ROAD DIST. NO.		ILLINOIS	FED. AID PROJECT	

Sheet 1 of 3 Sheets

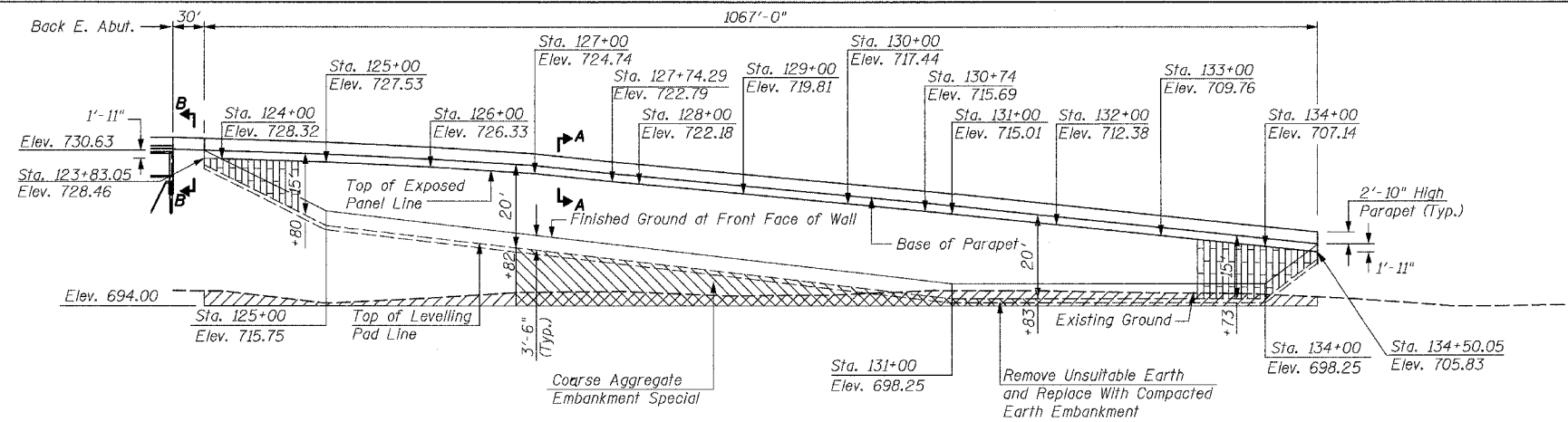

MARTIN J. SILVESTER
081-004373
LICENSED
STRUCTURAL
ENGINEER
CHICAGO, ILLINOIS
Signature: *M. J. Silvester* 02-02-2005
MARTIN J. SILVESTER
STRUCTURAL ENGINEER
LICENSE EXP. DATE 11-30-06

ELEVATION

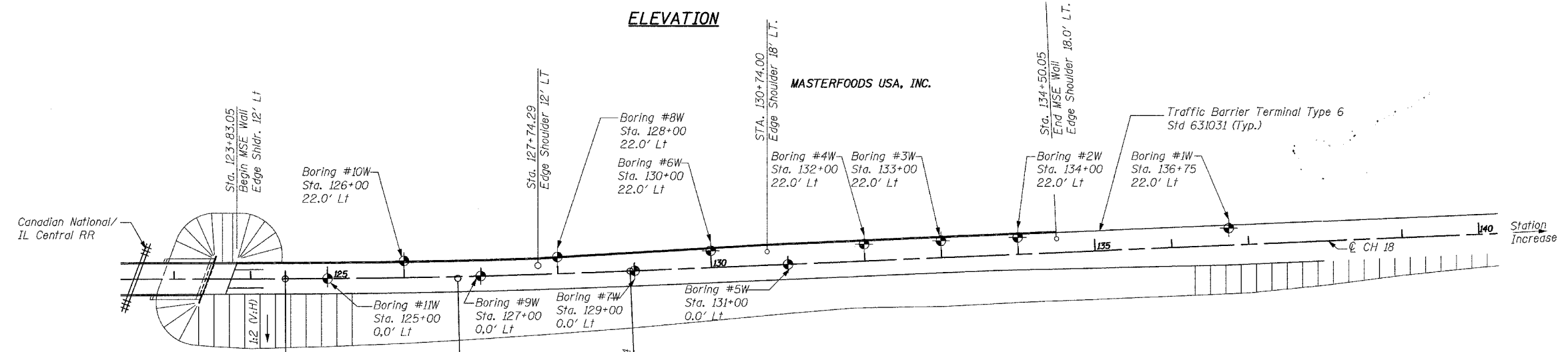

Prop. Curve 3
PI Sta. = 126+69.57
 $\Delta = 2^\circ 14' 17''$ (LT)
 $D = 0^\circ 29' 54''$
 $R = 11,500.00'$
 $T = 224.64'$
 $L = 449.21'$
 $E = 2.19'$
S.E. Run = None
P.C. Sta. = 124+44.93
P.T. Sta. = 128+94.14

PLAN

BILL OF MATERIAL

Item	Unit	Qty
Mechanically Stabilized Earth Retaining Wall	S.F.	17341

MARTIN J. SILVESTER
081-004373
LICENSED
STRUCTURAL
ENGINEER
CHICAGO, ILLINOIS
Signature: *M. J. Silvester* 02-02-2005

- The Contractor shall submit Shop Drawings and Calculations (Sealed by an Illinois Licensed Structural Engineer) of the Mechanically Stabilized Earth Retaining Wall in accordance with the Special Provision "Mechanically Stabilized Earth Retaining Walls".
- Work this Sheet with Sheets 2 and 3.
- See Sheet 3 for Section A-A.
- See "Bridge Approach Pavement Special" for Section B-B

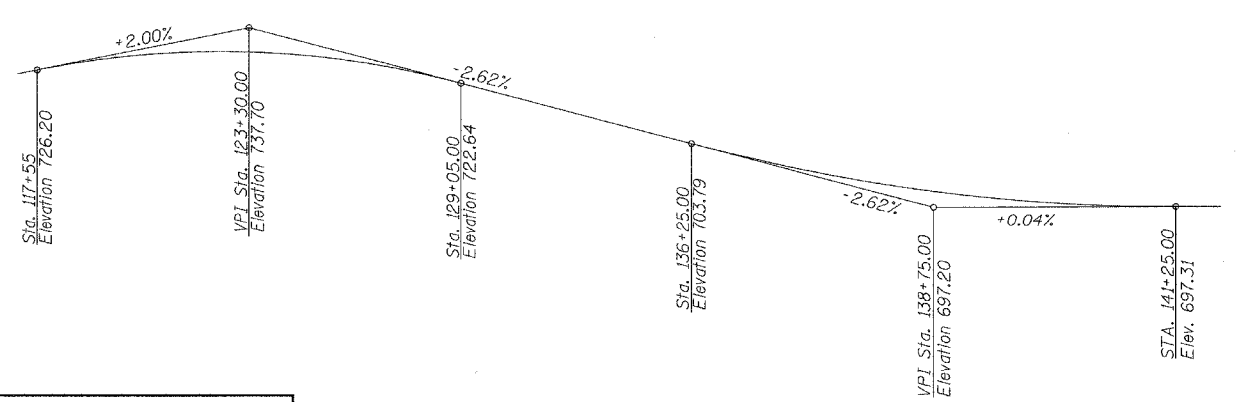

PROFILE GRADE

Along C.H. 18

DESIGN SPECIFICATIONS

2002 AASHTO

DESIGN STRESSES

$f'_c = 3,500$ psi (Concrete)
 $f'_c = 4,500$ psi (Panels)
 $f_y = 60,000$ psi (Reinf.)

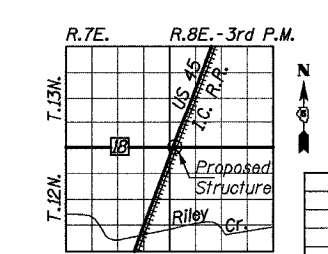

LOCATION SKETCH

THE UPCHURCH GROUP
HILLSIDE, IL. (708) 449-2321
MATTOON, IL. (217) 235-3177

REVISIONS	
NAME	DATE

ILLINOIS DEPARTMENT OF TRANSPORTATION
GENERAL PLAN
RETAINING WALL ON CH 18
FAS 642 SECTION 99-00124-01-PV
COLES COUNTY STR. No. 015-3412
STA. 123+53.07 TO STA. 135+50.07
SCALE: N.T.S. DRAWN BY LMP
DATE: 1-21-2004 CHECKED BY

F.A.P. RTE.	SECTION	COUNTY	TOTAL SHEETS	SHEET NO.
642	99-00124-01-PV	COLES	157	107
STA.	TO STA.			
FED. ROAD DIST. NO.	ILLINOIS	FED. AID PROJECT		

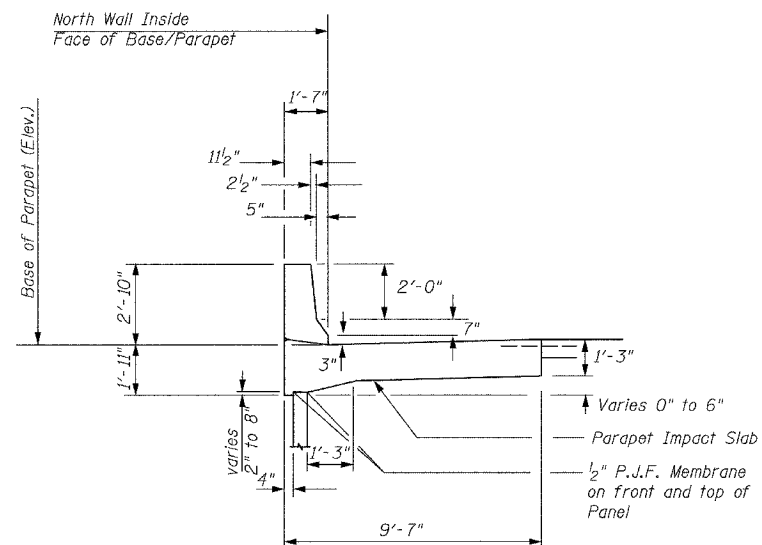

DETAIL A

The M.S.E. supplier's internal stability design shall account for the Parapet Impact Slabs bearing pressure of 1070 lbs/sq. ft. and Horizontal sliding force of 476 lbs./ft. of wall.

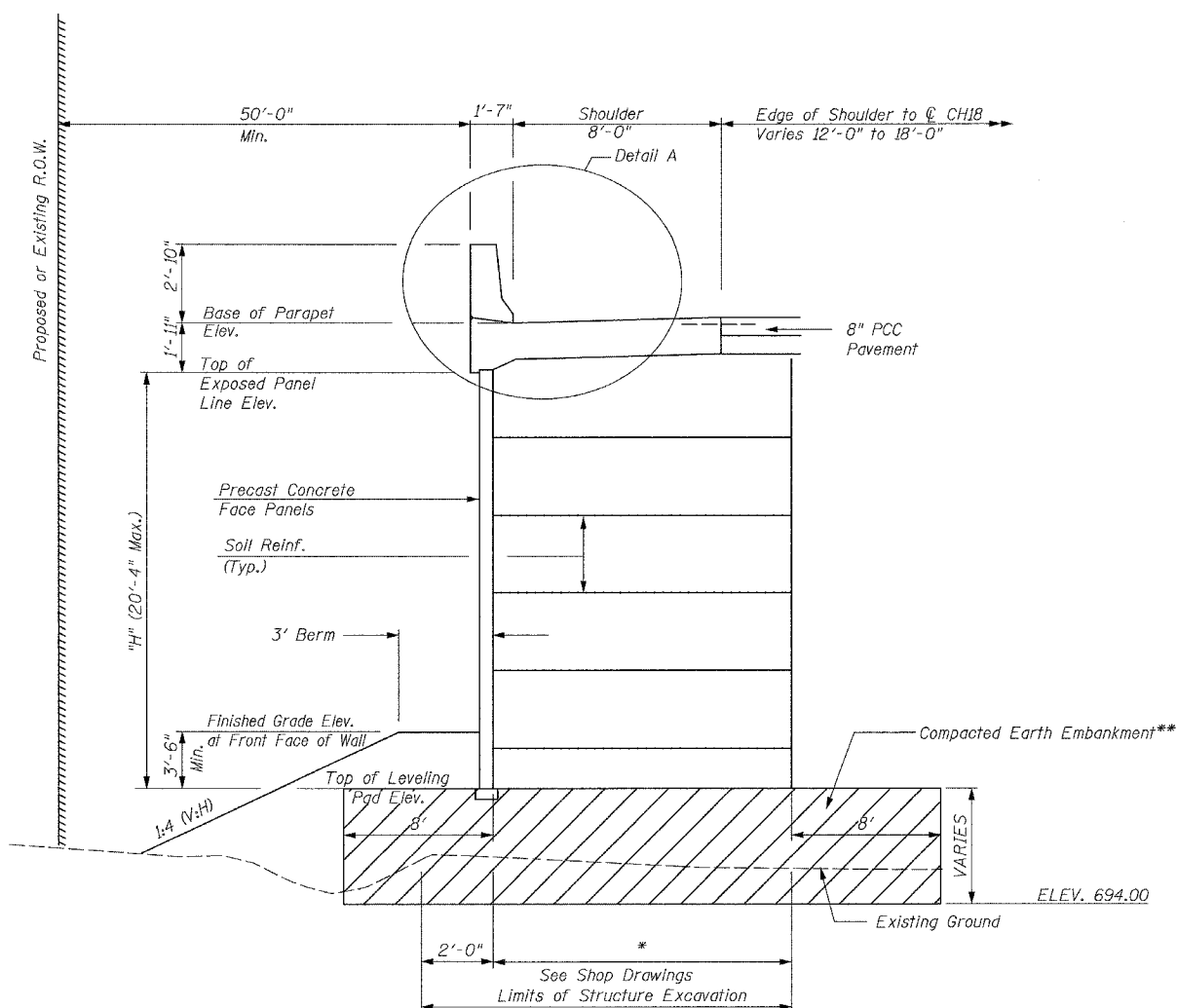

**SECTION A-A
TYPICAL WALL SECTION**

* Sta. 123+83.05 to Sta. 124+80 = 0.7 "H" > 8'-0" Min.
 Sta. 124+80 to Sta. 126+82 = 1.0 "H" > 8'-0" Min.
 Sta. 126+82 to Sta. 131+83 = 0.7 "H" > 8'-0" Min.
 Sta. 131+83 to Sta. 133+73 = 1.0 "H" > 8'-0" Min.
 Sta. 133+73 to Sta. 134+50 = 0.7 "H" > 8'-0" Min.

** Coarse Aggregate Embankment, Special shall be used when the wall height "H" is greater than 20'

Notes:
 Locations, sizes & elevations of main Drainage Structures are defined in the Roadway Drainage Plans.

MSE Supplier to Design Load Transfer systems for all Drainage Structures and Storm Sewer Pipes.

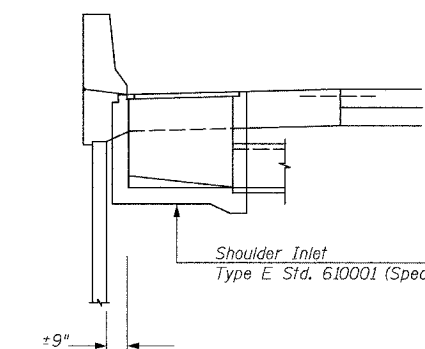

**SECTION THRU
DRAINAGE STRUCTURES**

GENERAL NOTES

For Wall Heights "H" 13'-1" or less

(Sta. 123+83 to Sta. 124+80)
 (Sta. 133+73 to Sta. 134+50)

New fill material under MSE system may consist of compacted earth embankment exhibiting an unconfined compressive strength (Qu) of 1.5 tsf.

For Wall Heights "H" Greater than 13'-1" up to 18'-1"

(Sta. 124+80 to Sta. 126+82)
 (Sta. 131+83 to Sta. 133+73)

New fill material under MSE system shall consist of compacted earth embankment exhibiting an unconfined compressive strength (Qu) of 1.5 tsf.

For Wall Heights "H" Greater than 18'-1"

(Sta. 126+82 to Sta. 131+83)

New fill material under MSE system shall consist of Coarse Aggregate Embankment, Special exhibiting a minimum angle of internal resistance of 31 degrees.

THE UPCHURCH GROUP

HILLSIDE, IL. (708) 449-2821
 MATTOON, IL. (217) 236-3177

REVISIONS	
NAME	DATE

ILLINOIS DEPARTMENT OF TRANSPORTATION
WALL DETAILS
 RETAINING WALL ON CH 18
 FAS 642 SECTION 99-00124-01-PV
 COLES COUNTY STR. No. 015-3412
 STA. 123+53.07 TO STA. 135+50.07
 SCALE: DRAWN BY LMP
 DATE: 1-21-2004 CHECKED BY

F.A.P. RTE.	SECTION	COUNTY	TOTAL SHEETS	SHEET NO.
642	99-00124-01-PV	COLES	157	108
STA.		TO STA.		
FED. ROAD DIST. NO.	ILLINOIS	FED. AID PROJECT		

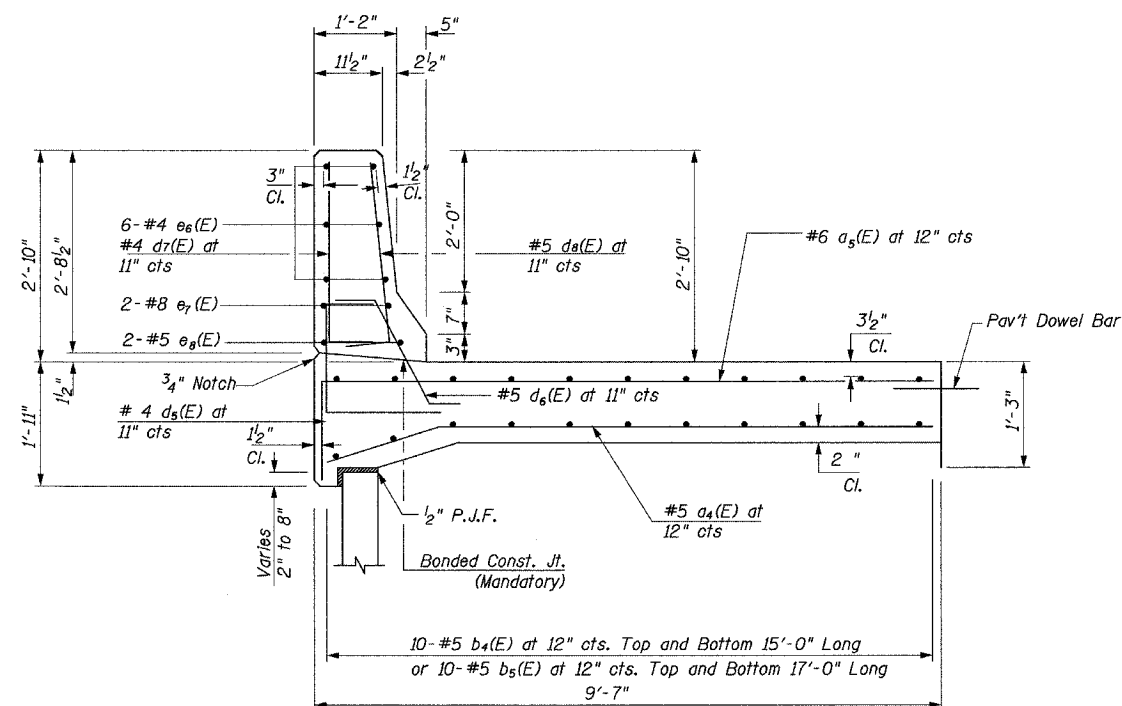

TYPICAL SECTION A-A

(Longitudinal Construction Joints in Parapet Impact Slab at 15'-0" centers. See note 1)

(70 Slabs 15'-0" Long Required
1 Slab 17'-0" Long Required)

BILL OF MATERIAL

Bar	No.	Size	Length (ft)	Shape
a4(E)	1068	#5	9'-3"	—
a5(E)	1068	#6	10'-8"	—
b4(E)	1400	#5	14'-8"	—
b5(E)	20	#5	16'-8"	—
d4(E)	1165	#4	3'-2"	┌
d6(E)	1165	#5	3'-1"	└
d7(E)	1165	#4	3'-0"	—
d8(E)	1165	#5	3'-0"	—
e6(E)	216	#4	29'-8"	—
e7(E)	72	#8	29'-8"	—
e8(E)	72	#5	29'-8"	—
Item		Unit	Qty.	
Reinforcement Bars, Epoxy Coated		lb	73580	
Concrete Structures		Cu. Yd.	624.6	

MIN. BAR LAP PARAPET

- #4 bars = 1'-4"
- #5 bars = 1'-8"
- #8 bars = 3'-5"

Notes:

1. Provide Bulkhead Longitudinal Construction Joint in Parapet Impact Slab as detailed on Standard 420001 at 15'-0" centers.
2. Construction Joints in Parapet shall either be at the same location as the Joints in the Parapet Impact Slab or the Parapet Wall may be continuously slip formed.
3. Reinforcement bars designated (E) shall be epoxy coated.
4. Work this sheet with sheet 1 and 2 of 3

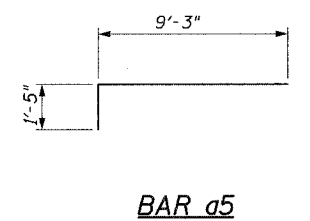
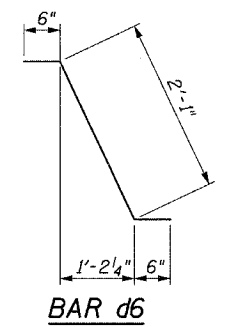
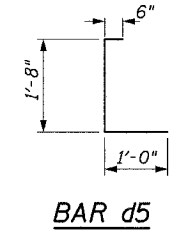
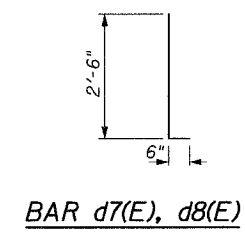

THE UPCHURCH GROUP

HILLSIDE, IL. (708) 449-2321
MATTOON, IL. (217) 235-3177

REVISIONS	
NAME	DATE

ILLINOIS DEPARTMENT OF TRANSPORTATION
REINFORCEMENT DETAILS
RETAINING WALL ON CH 18
FAS 642 SECTION 99-00124-01-PV
COLES COUNTY STR. No. 015-3412
STA. 123+53.07 TO STA. 135+50.07

SCALE: DRAWN BY LMP
DATE: 1-21-2004 CHECKED BY MJS

SECTION	COUNTY	TOTAL SHEETS	SHEET NO.
99-00124-01-PV	COLES	157	109

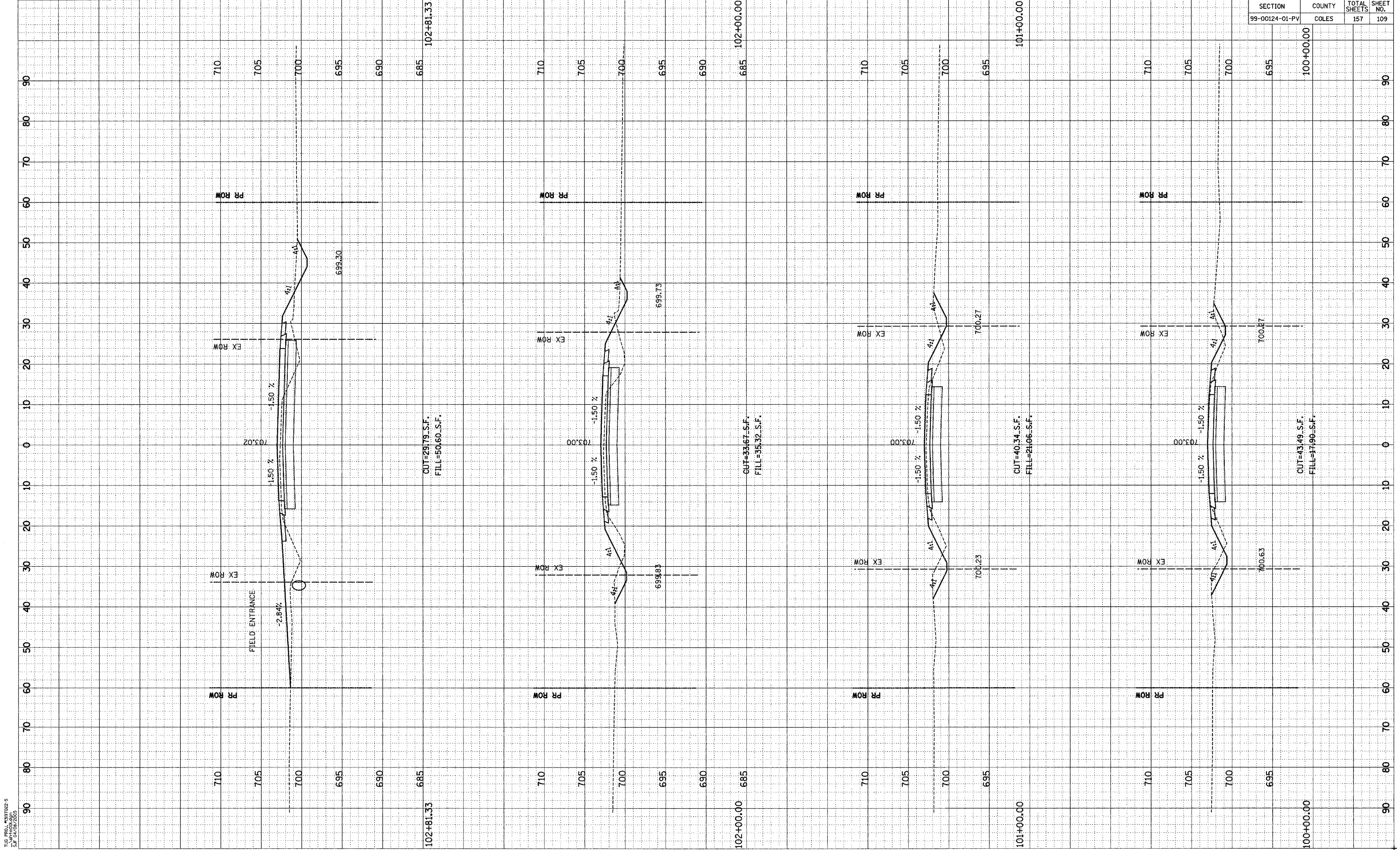

TUG PROJ. #319702-5
 DATE: 11/10/2010
 BY: J. J. JONES

TUG PROJ. #387022-5
 DATE: 11/03/10
 BY: JWB/255

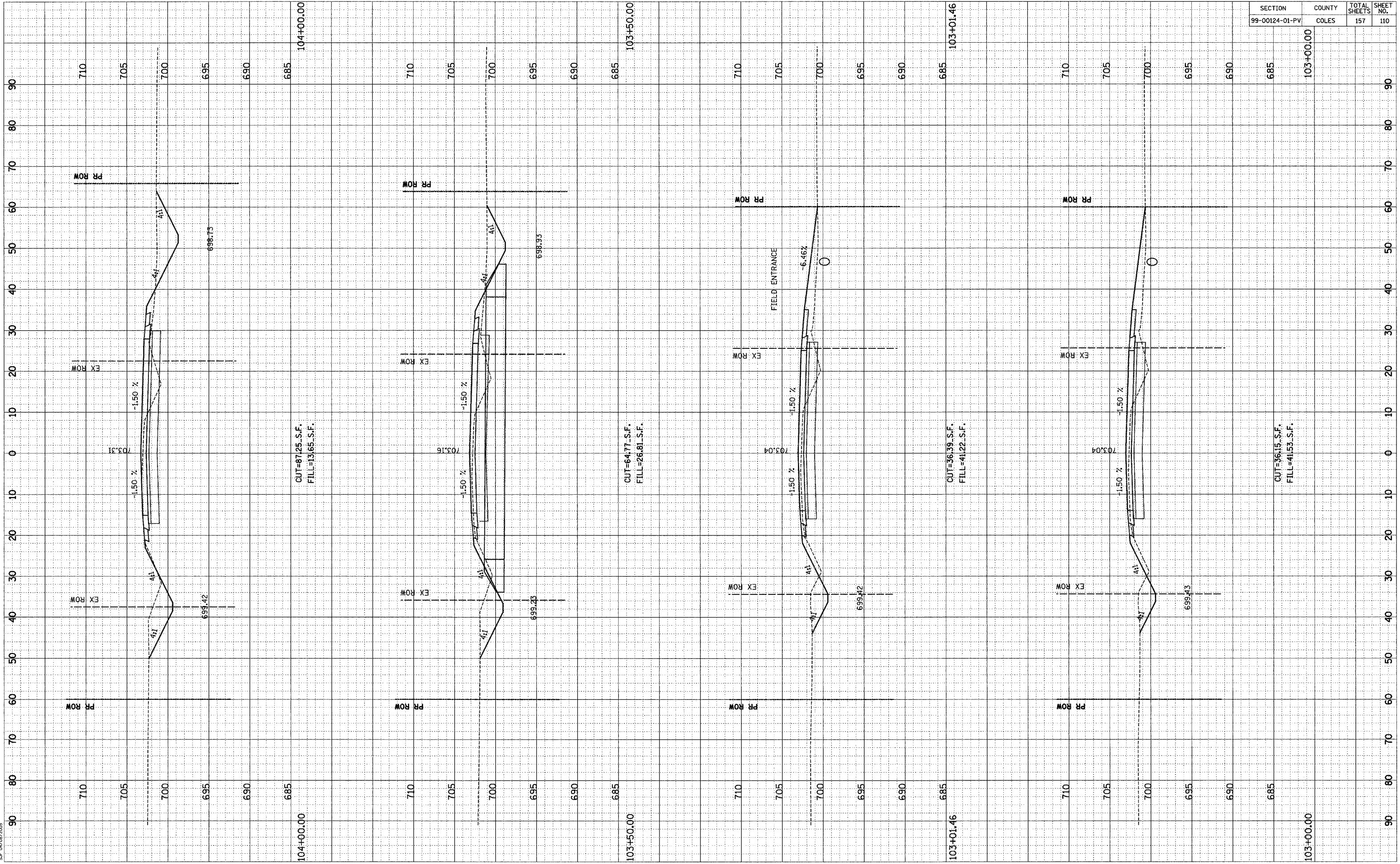

SECTION	COUNTY	TOTAL SHEETS	SHEET NO.
99-00124-01-PV	COLES	157	111

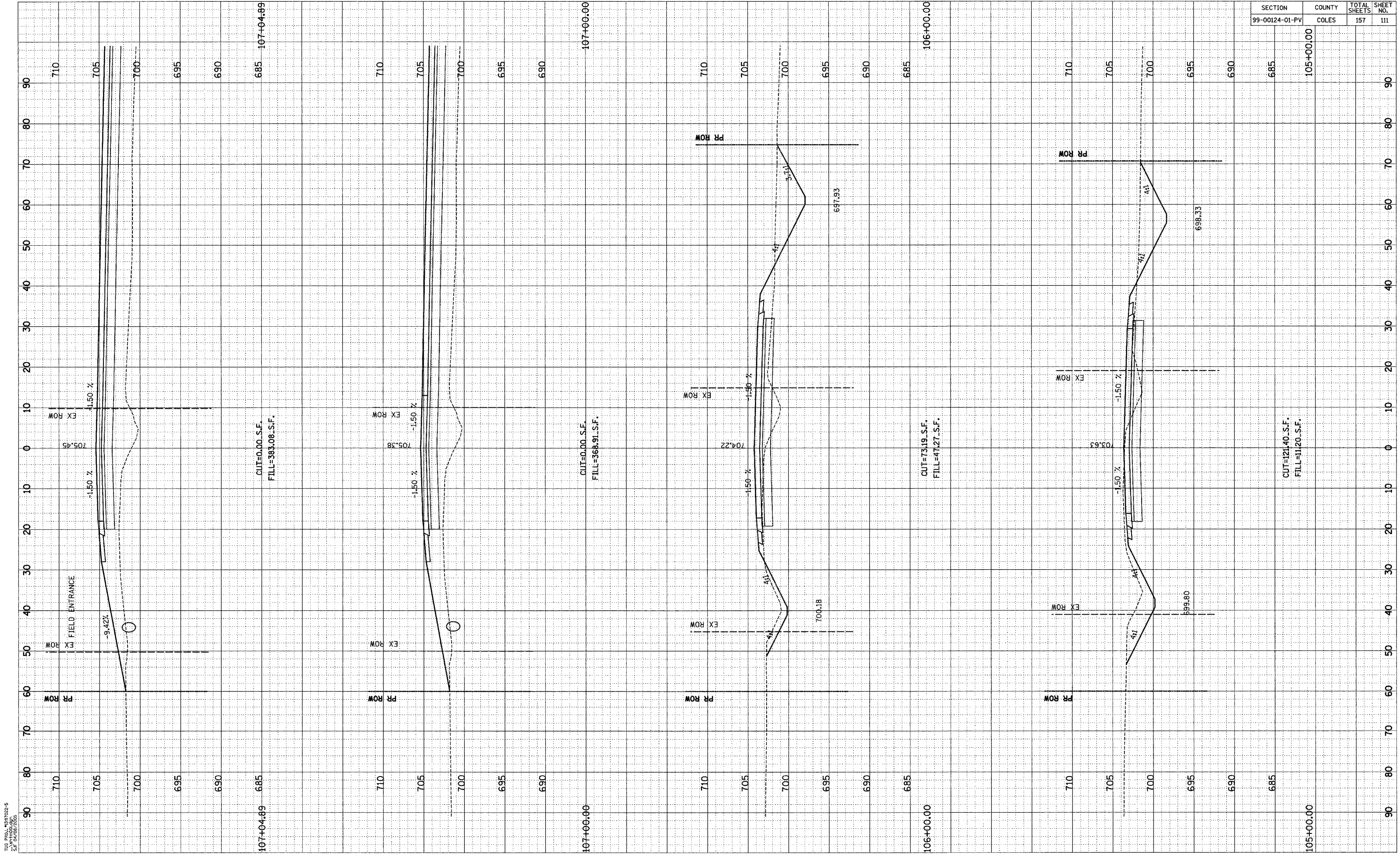

TUG PROJ. #397022-5
 DATE: 11/09/05
 BY: 5/26/05

SECTION	COUNTY	TOTAL SHEETS	SHEET NO.
99-00124-01-PV	COLES	157	112

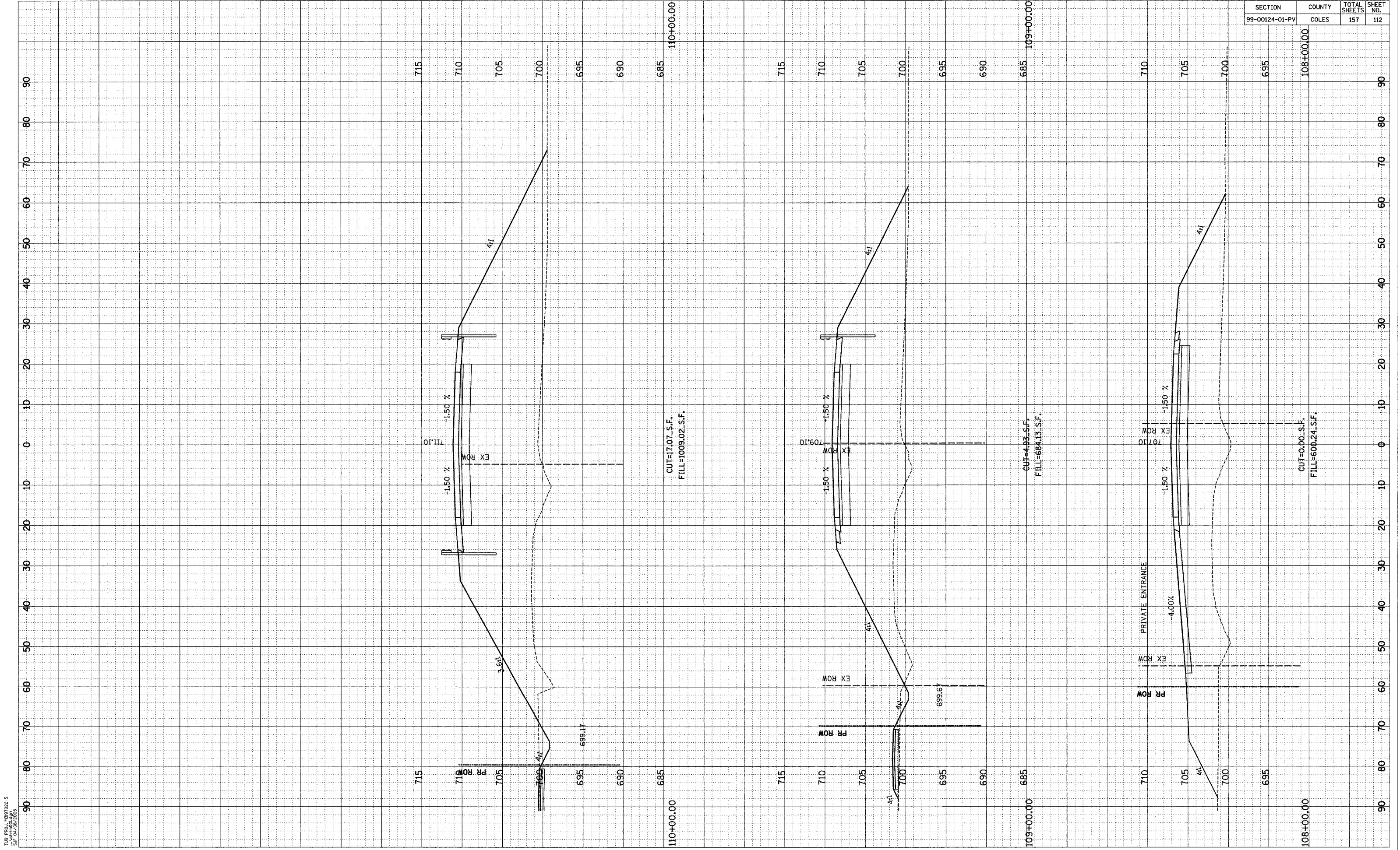

TUG PROJ. #097022-5
 DATE: 11/10/2009
 BY: JWB/2305

SECTION	COUNTY	TOTAL SHEETS	SHEET NO.
99-00124-01-PV	COLES	157	113

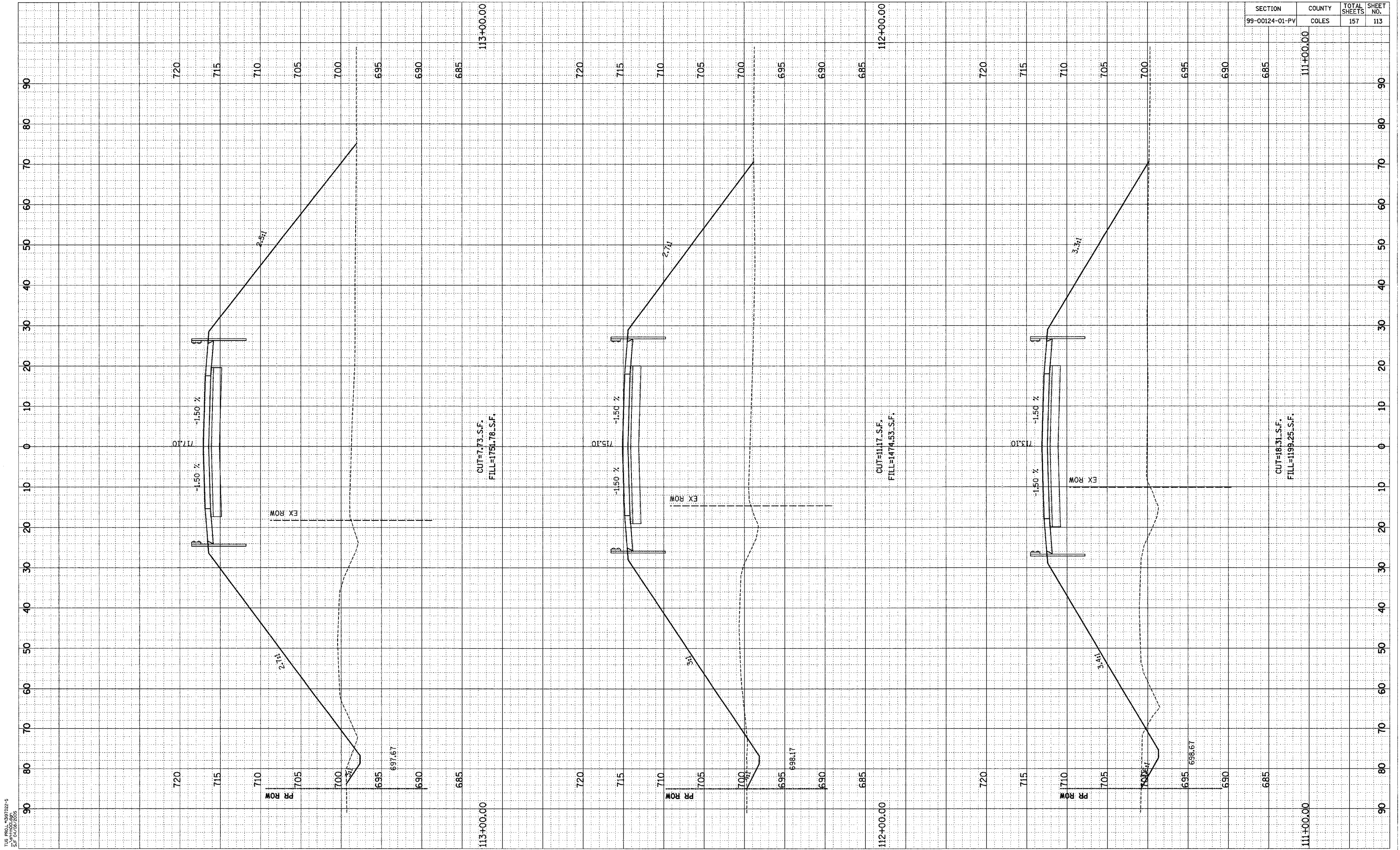

TUG PROJ. #957022-5
 DATE 11/01/05
 BY 2/28/05

SECTION	COUNTY	TOTAL SHEETS	SHEET NO.
99-00124-01-PV	COLES	157	114

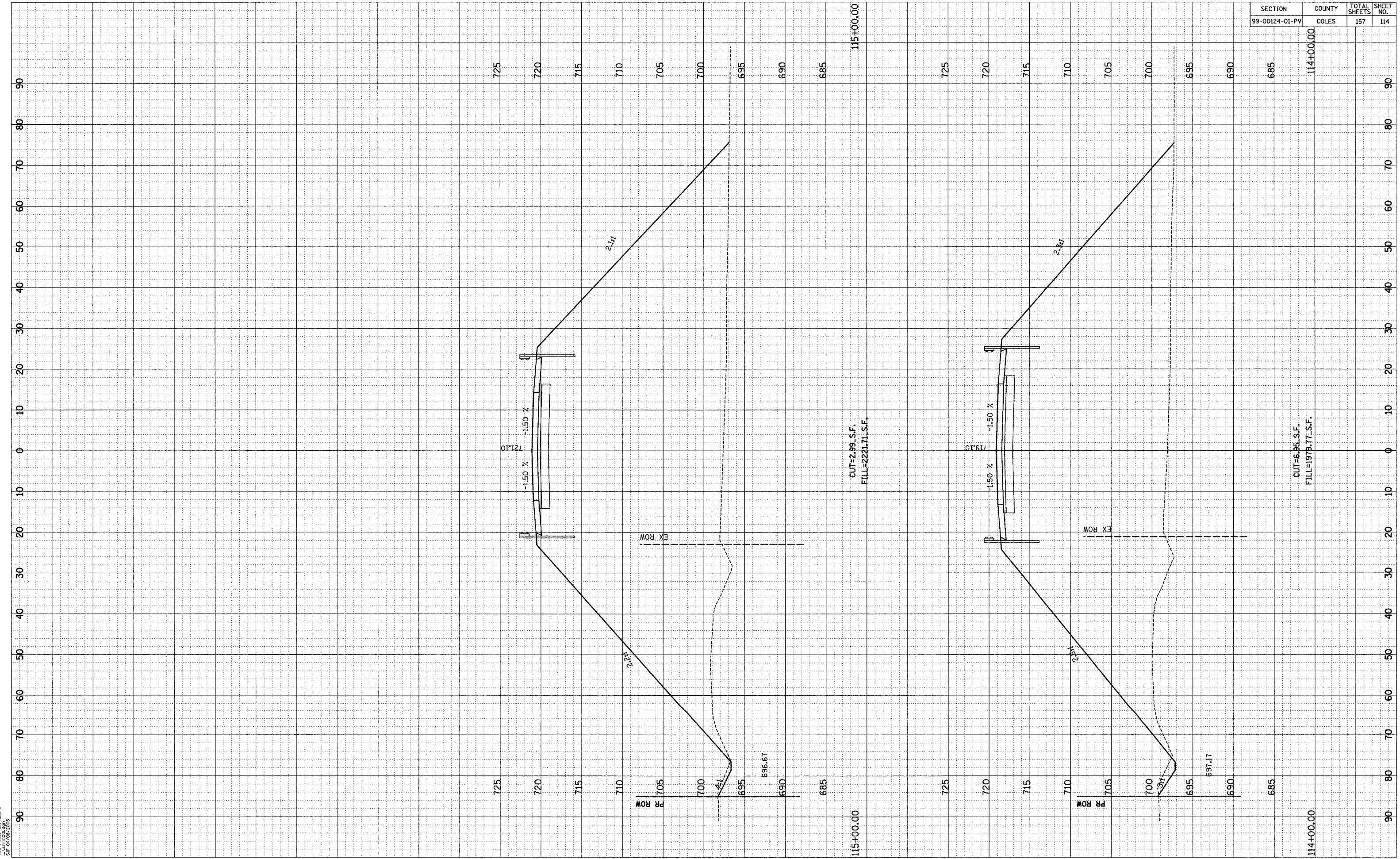

TUG PICAL MUSE 0202-5
 SA 011100 0505
 SA 011100 0505

SECTION	COUNTY	TOTAL SHEETS	SHEET NO.
99-00124-01-PV	COLES	157	115

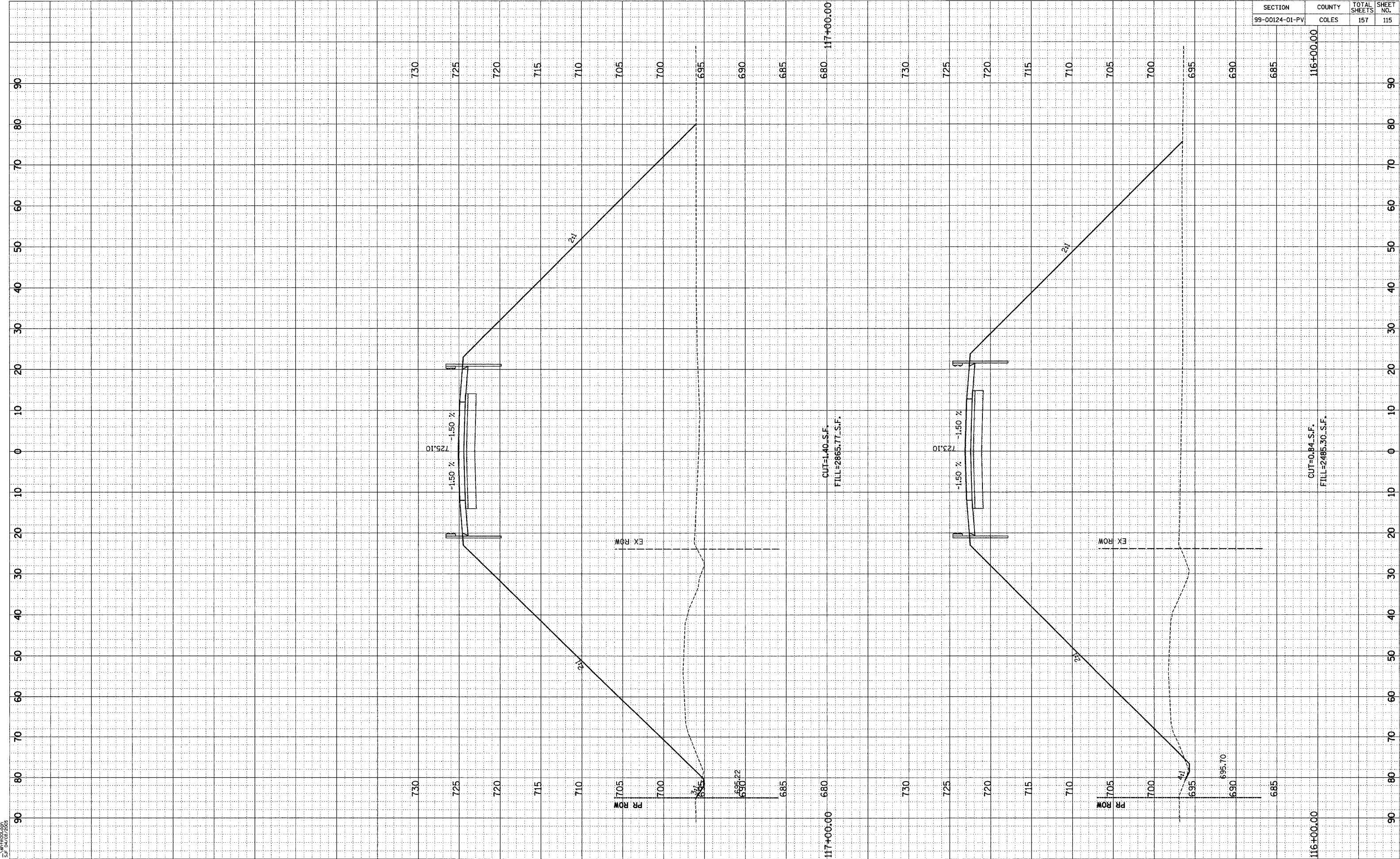

TUG PROJ: 091292-5
S.F. 04/28/2006

SECTION	COUNTY	TOTAL SHEETS	SHEET NO.
99-00124-01-PV	COLES	157	116

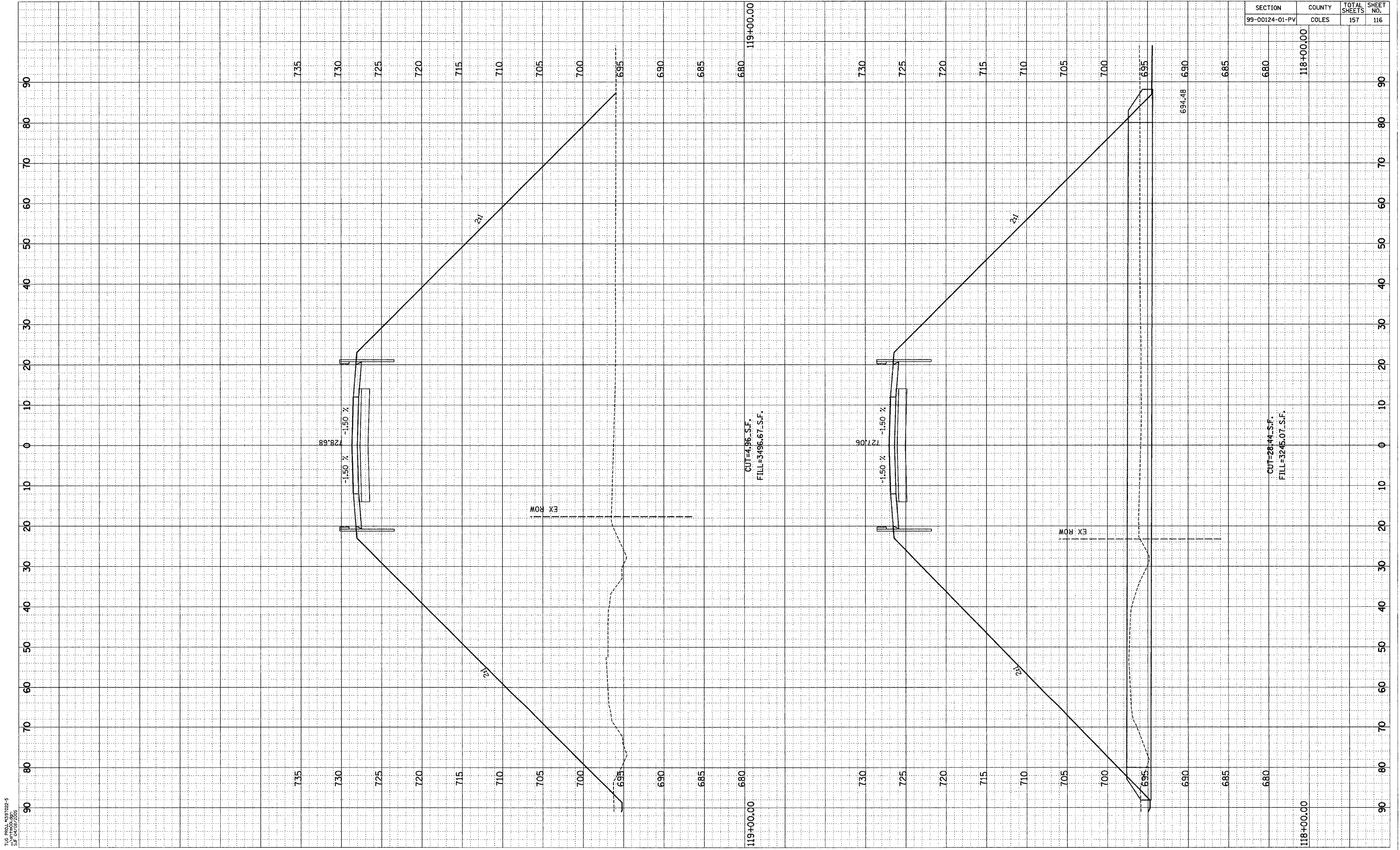

TUG PRAL #387022-5
 28 11/10/09
 28 11/10/09

SECTION	COUNTY	TOTAL SHEETS	SHEET NO.
99-00124-01-PV	COLES	157	117

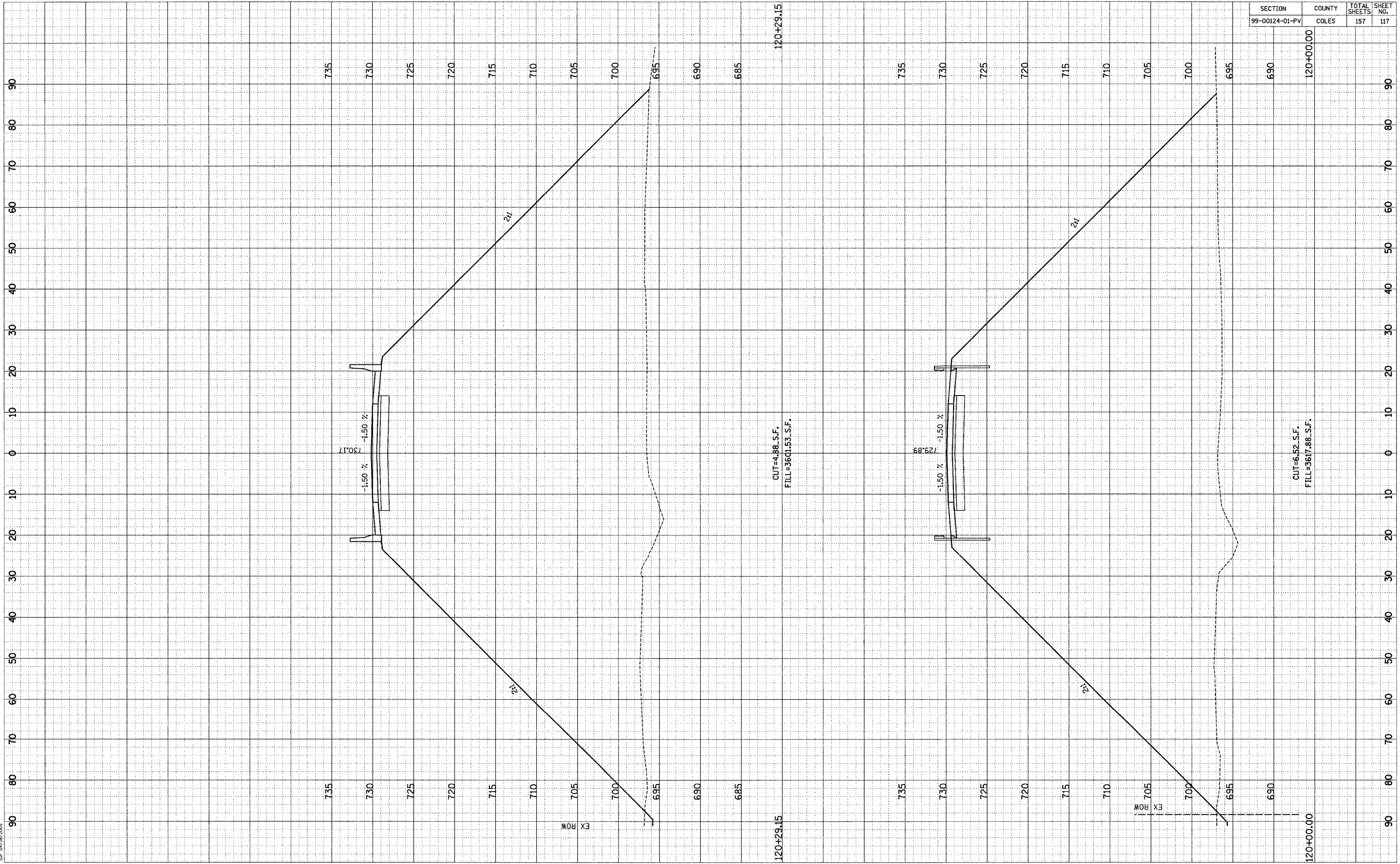

TUG PROJ: 0367022-5
 DATE: 01/10/01
 DRAWN BY: JMB

SECTION	COUNTY	TOTAL SHEETS	SHEET NO.
99-00124-01-PV	COLES	157	118

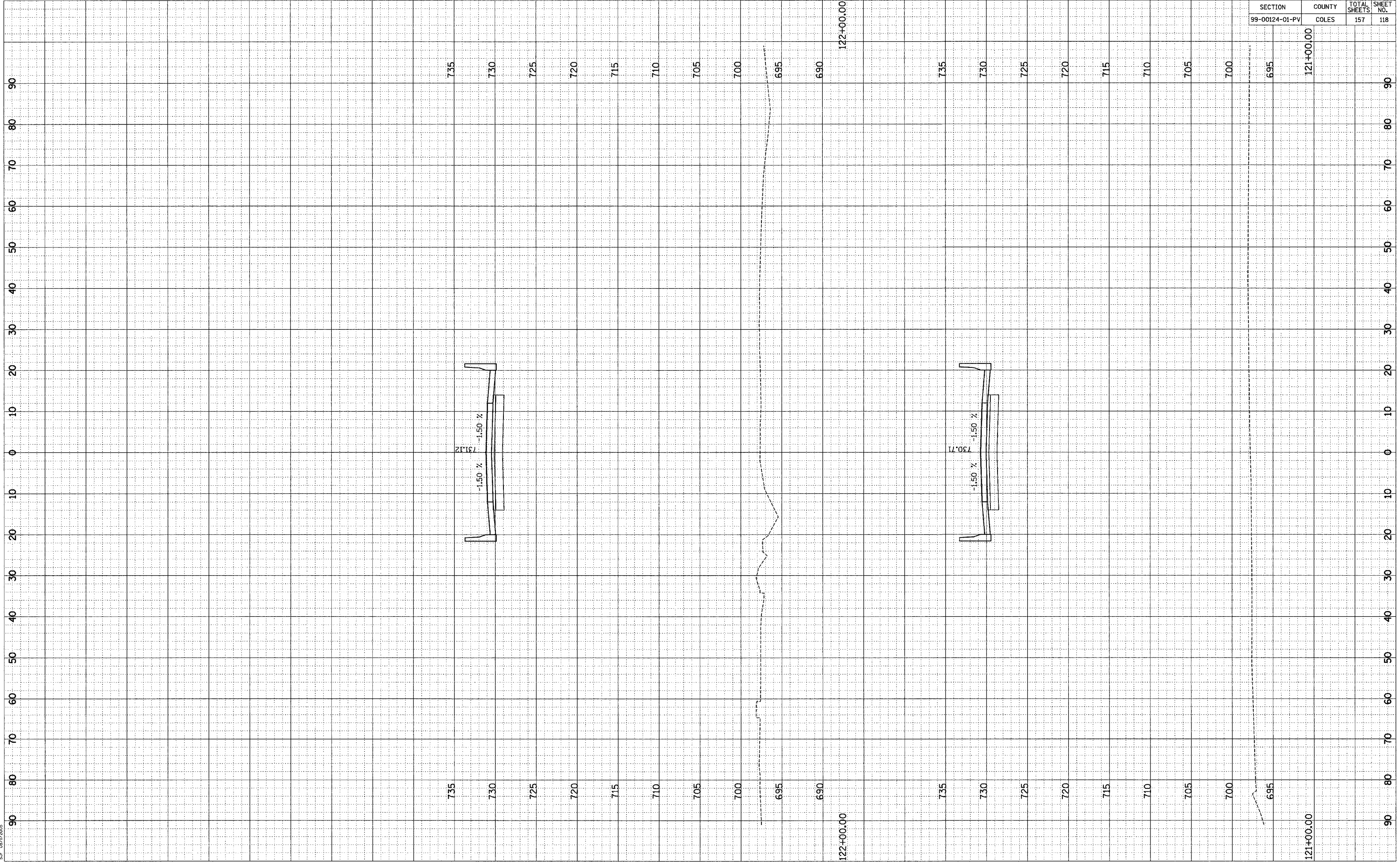

TUG PROJ. #358702-5
25' HORIZONTAL
50' VERTICAL

SECTION	COUNTY	TOTAL SHEETS	SHEET NO.
99-00124-01-PV	COLES	157	119

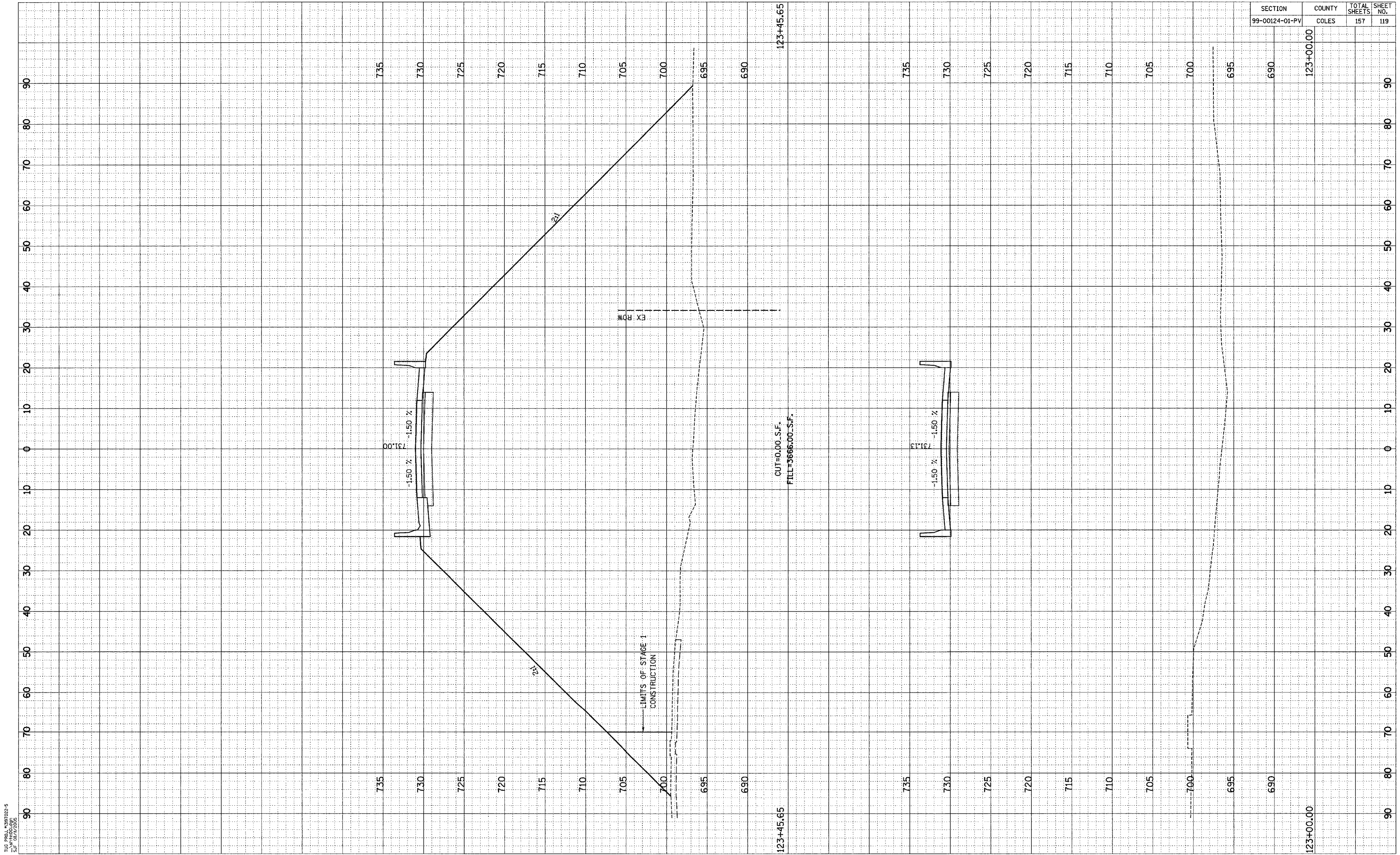

TUG PROJ # 091292-5
 C:_temp\01.dwg
 09/17/2009

SECTION	COUNTY	TOTAL SHEETS	SHEET NO.
99-00124-01-PV	COLES	157	120

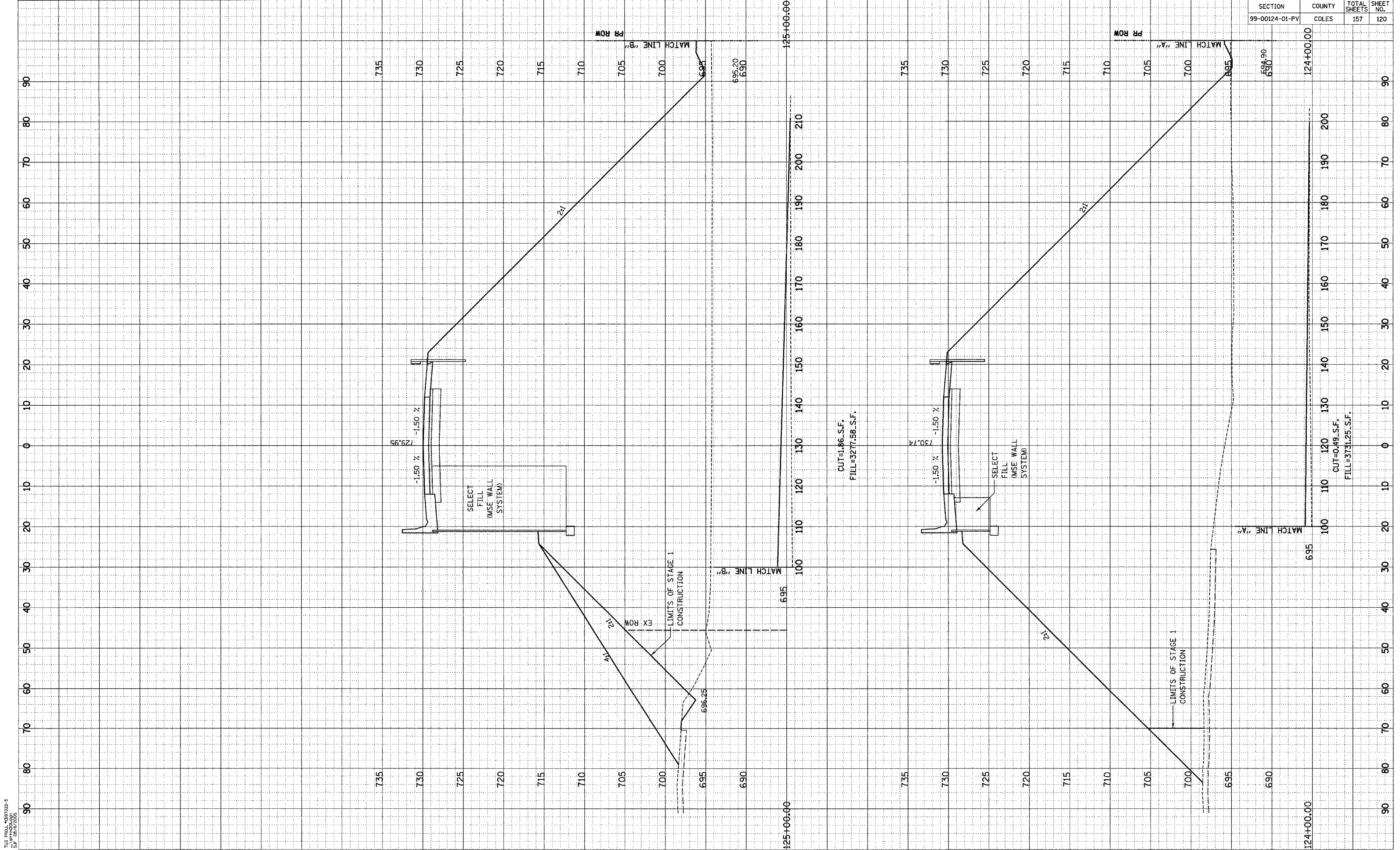

TUG PROL. 4387022-5
S:\PROJECTS\99-00124-01-PV\99-00124-01-PV.dwg
DATE: 08/17/2005

SECTION	COUNTY	TOTAL SHEETS	SHEET NO.
99-00124-01-PV	COLES	157	121

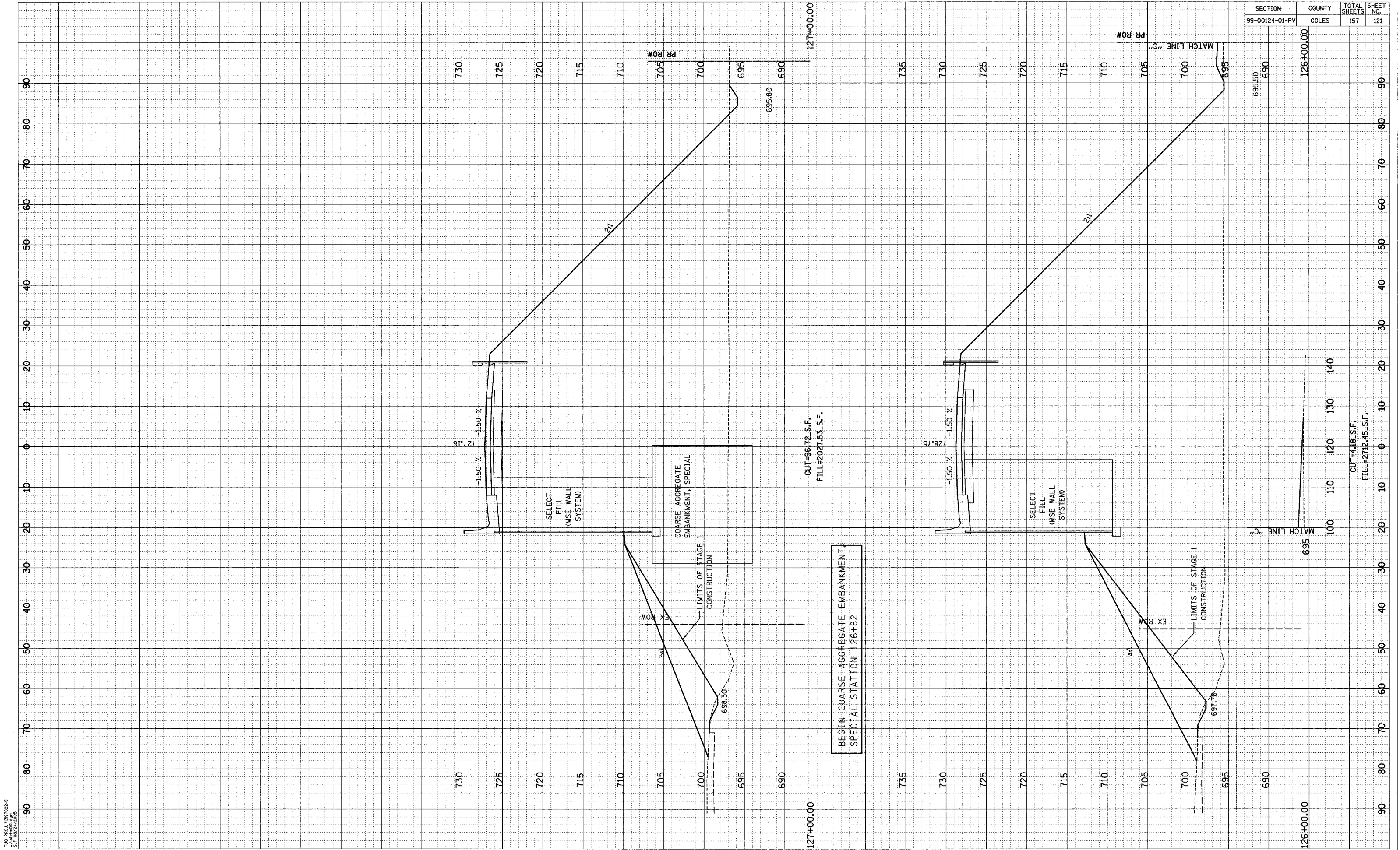

TUG PROJ. #991022-5
 S:\991022\DWG
 2007-07-05

SECTION	COUNTY	TOTAL SHEETS	SHEET NO.
99-00124-01-PV	COLES	157	122

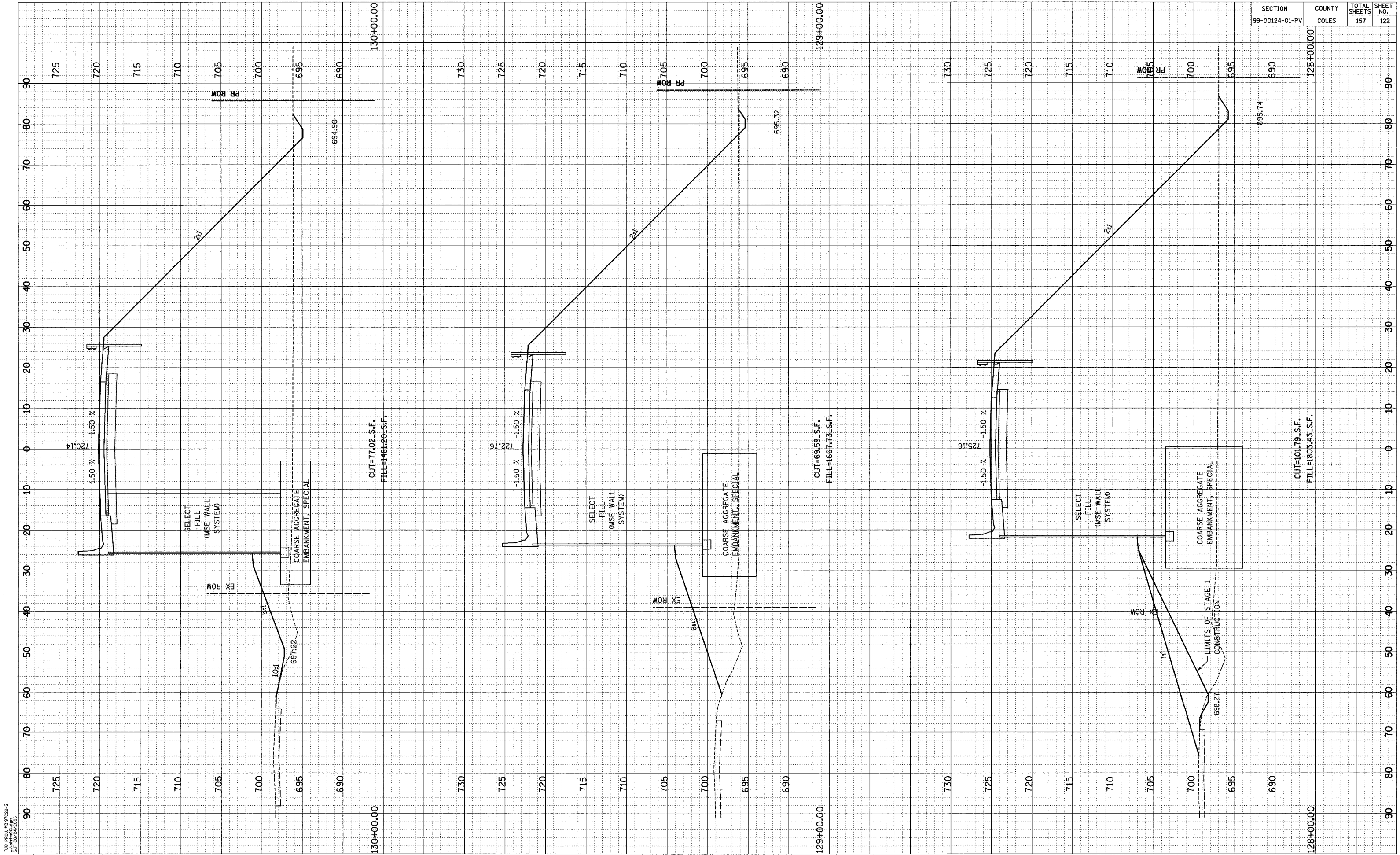

TUG PROJ. #997022-5
S:\PROJECTS\997022-5

SECTION	COUNTY	TOTAL SHEETS	SHEET NO.
99-00124-01-PV	COLES	157	123

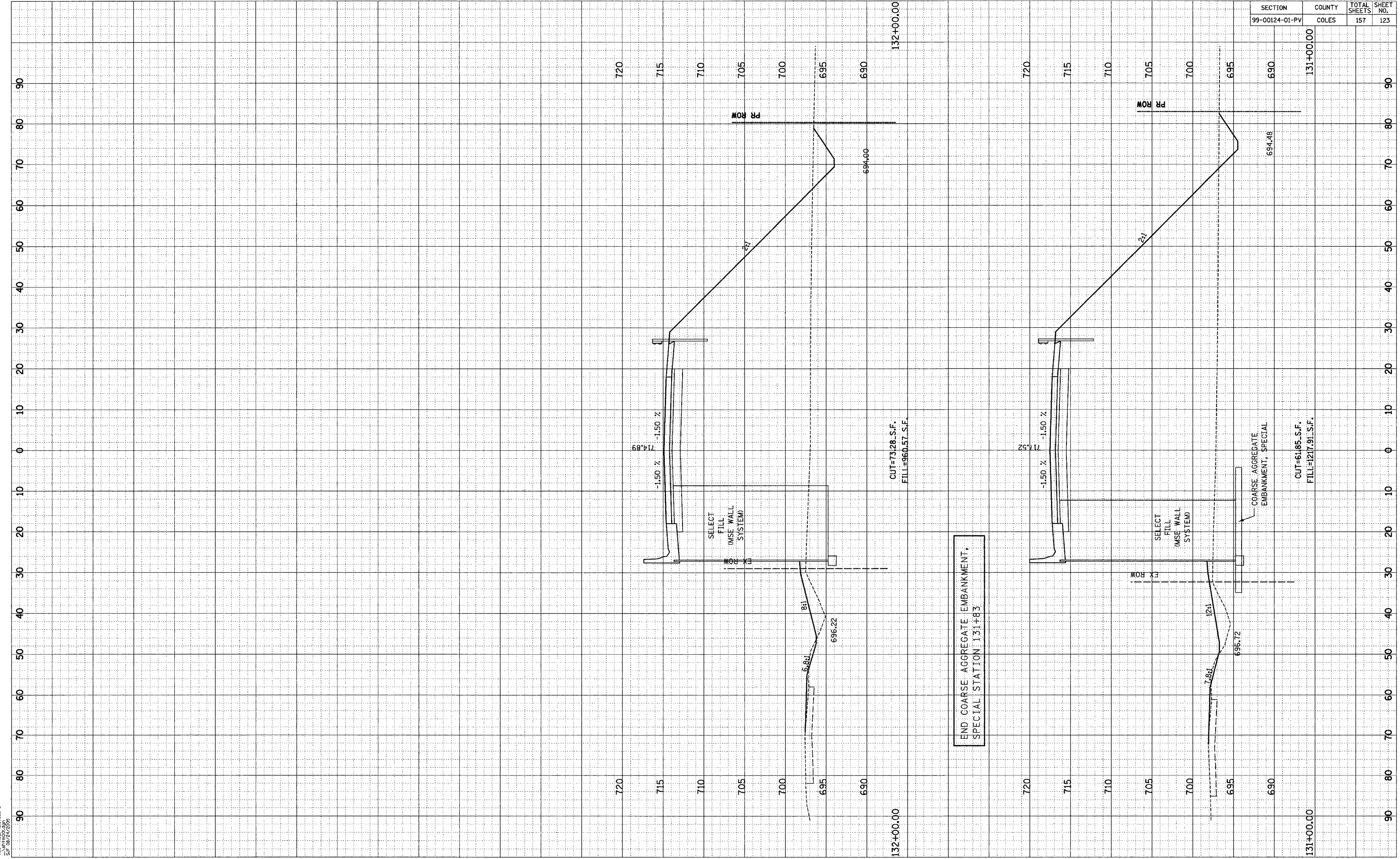

END COARSE AGGREGATE EMBANKMENT.
SPECIAL STATION 131+83

TUG PROJ #387022-5
S:\PROJ\387022-5

SECTION	COUNTY	TOTAL SHEETS	SHEET NO.
99-00124-01-PV	COLES	157	124

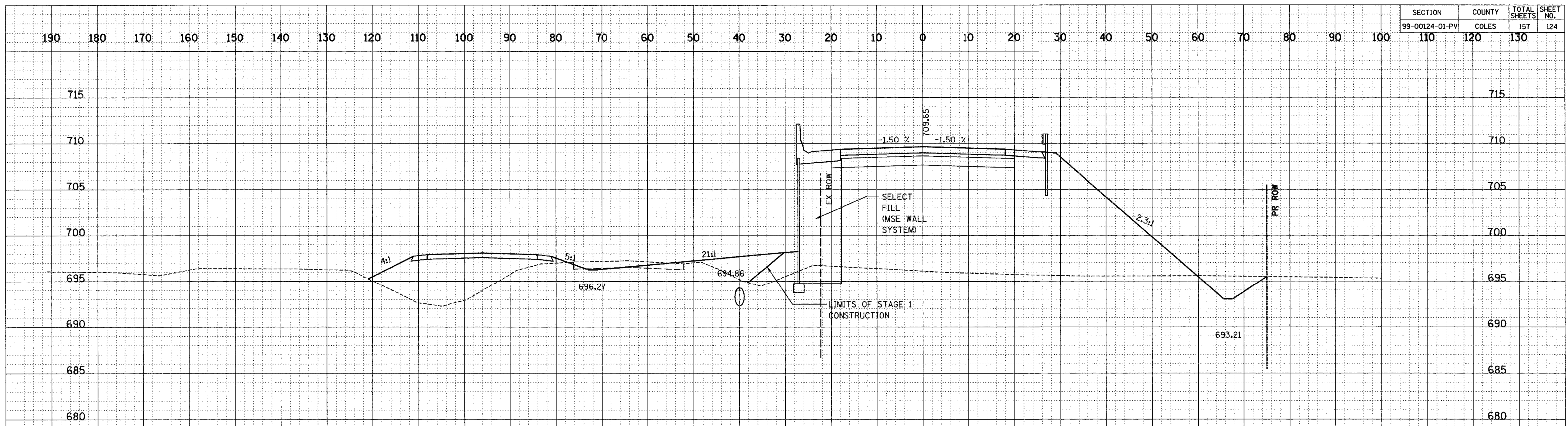

CUT=53.39 S.F.
 FILL=958.98 S.F.

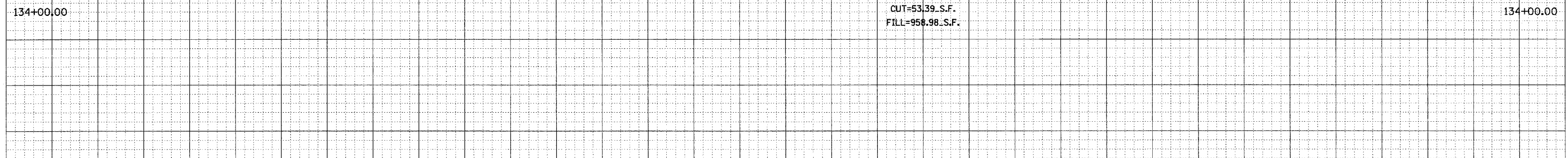

CUT=75.13 S.F.
 FILL=883.28 S.F.

THE UPCHURCH GROUP, INC. 1810 CHARLESTON AVE, MATTOON, ILLINOIS 61938, (217) 235-3177
 DATE: 07/01/2005

SECTION	COUNTY	TOTAL SHEETS	SHEET NO.
99-00124-01-PV	COLES	157	125
110	120	130	

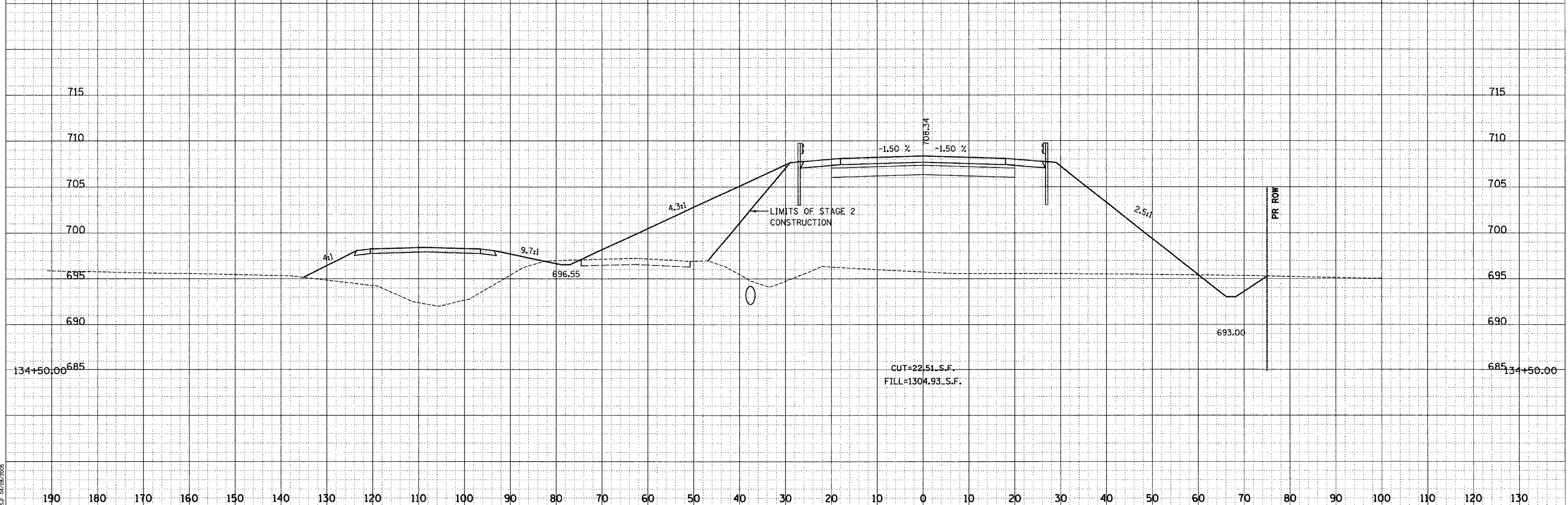
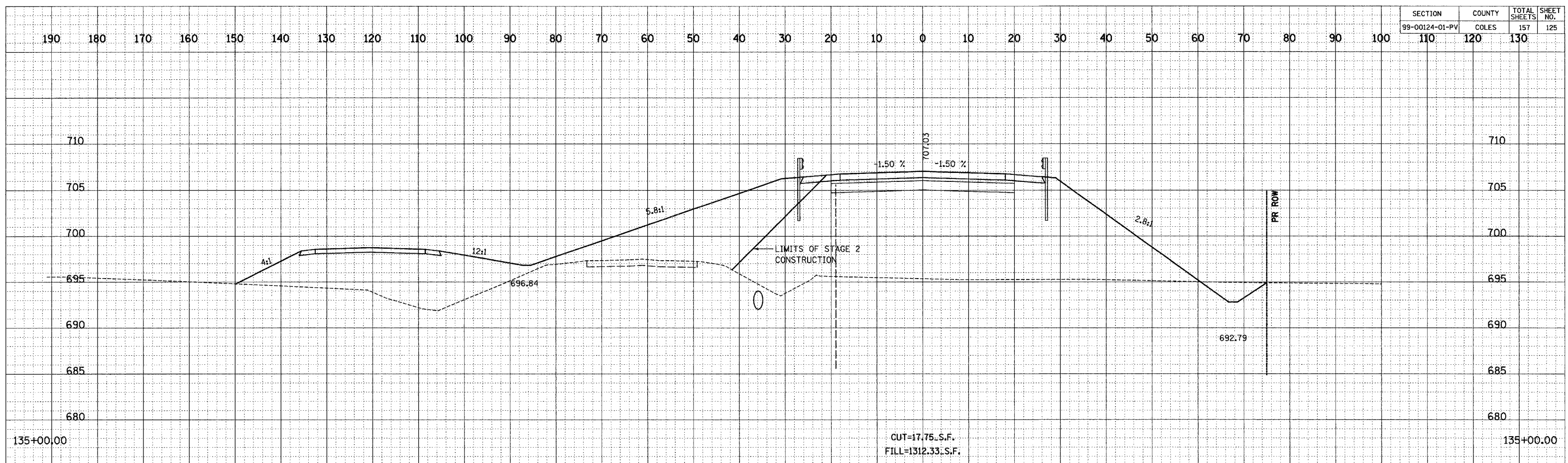

TUG PROJ. #387022-5
DATE: 04/07/2005

SECTION	COUNTY	TOTAL SHEETS	SHEET NO.
99-00124-01-PV	COLES	157	126

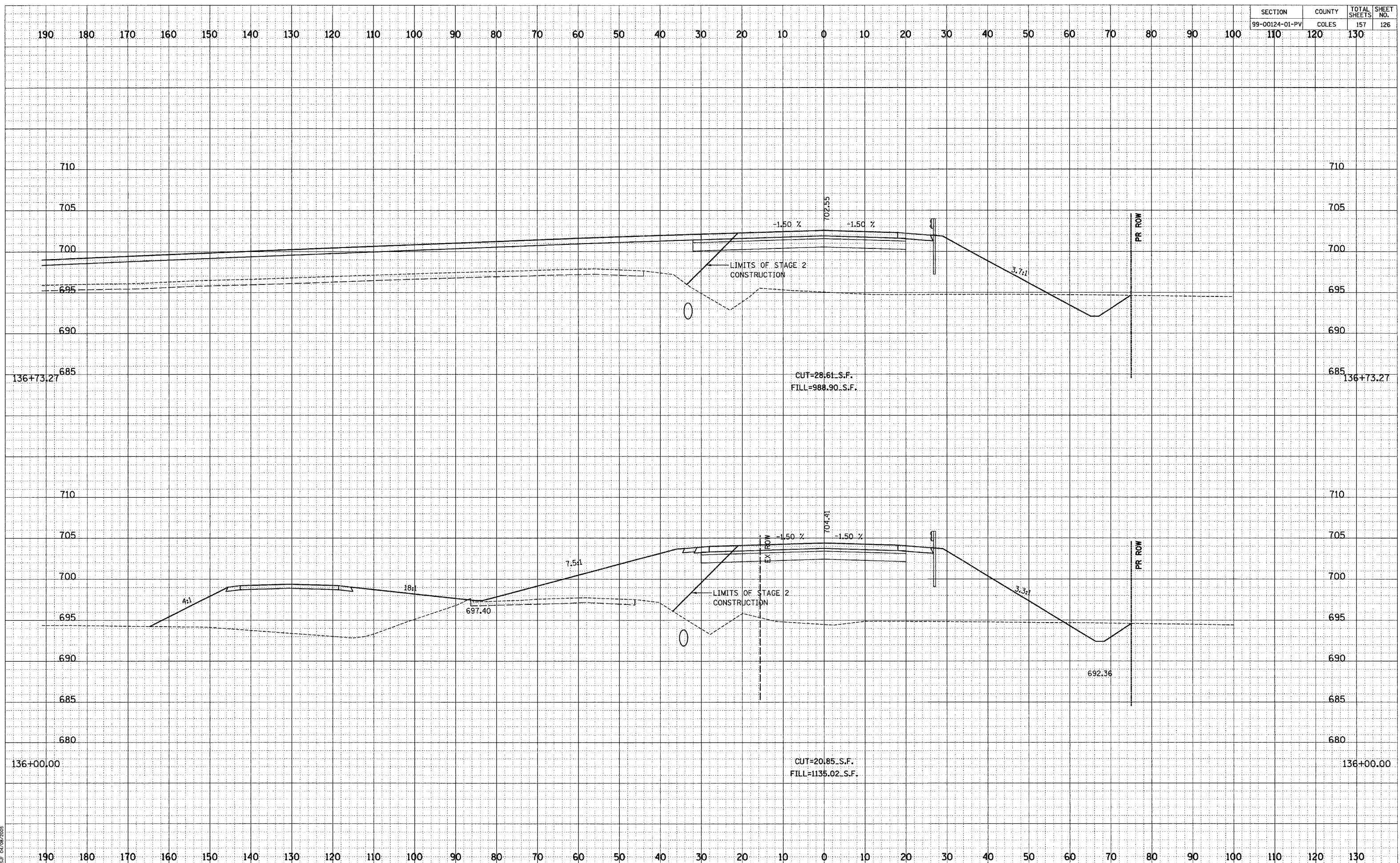

TUG PROJ: 03/07/02-5
DATE: 03/07/02

SECTION	COUNTY	TOTAL SHEETS	SHEET NO.
99-00124-01-PV	COLES	157	127
110	120	130	

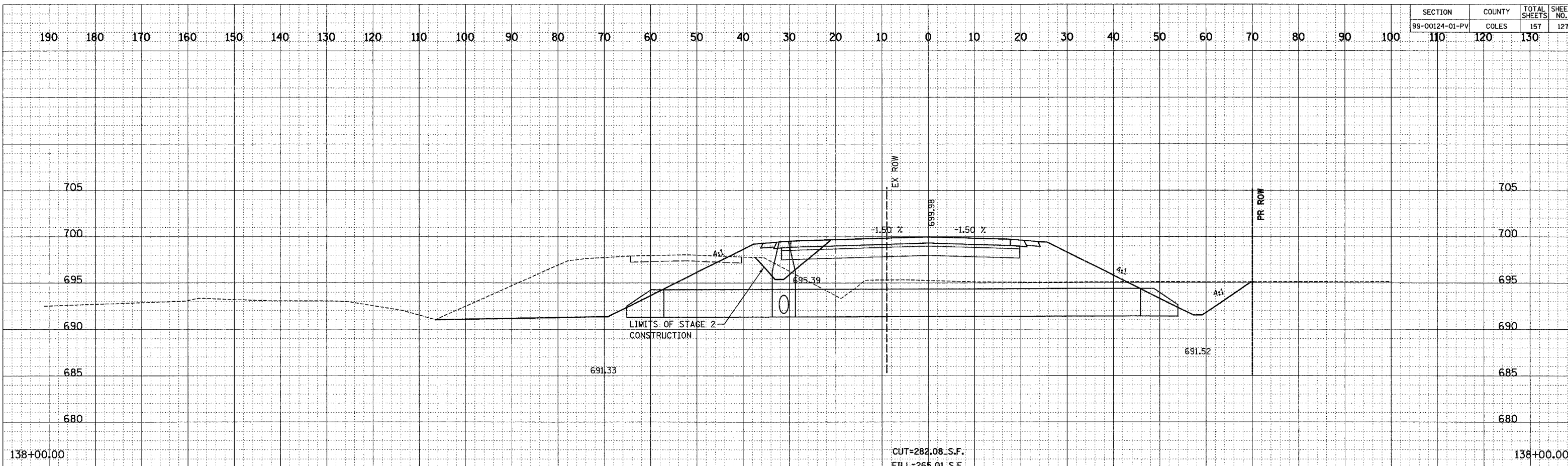

CUT=282.08 S.F.
FILL=265.01 S.F.

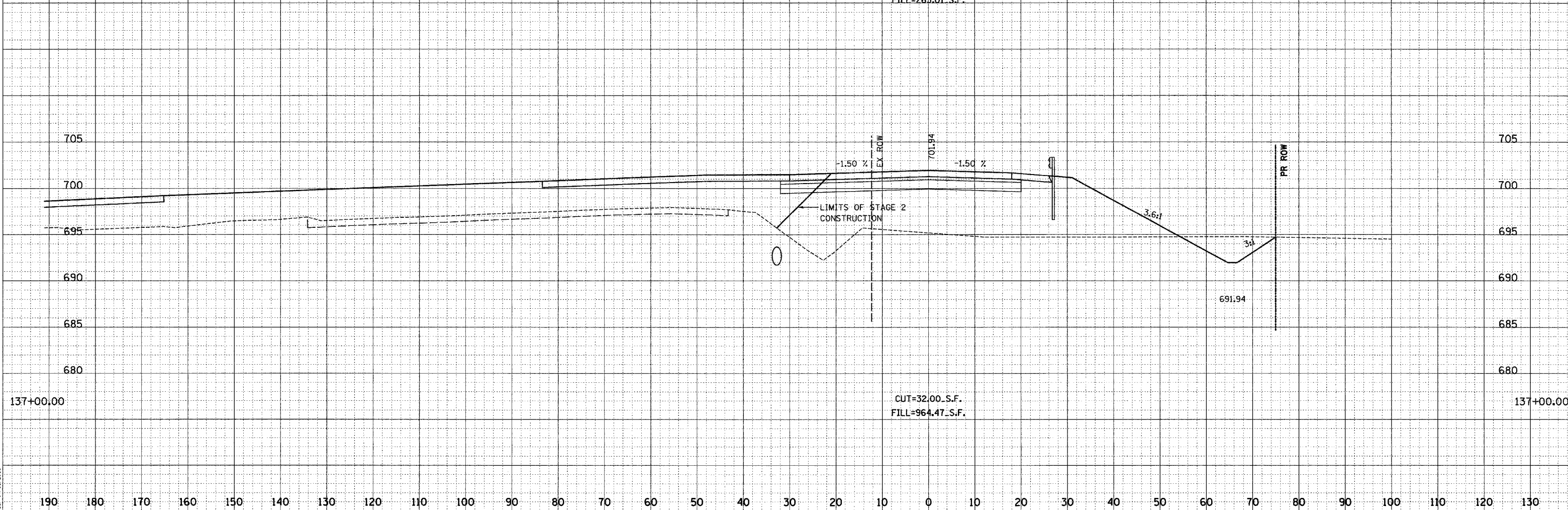

CUT=32.00 S.F.
FILL=964.47 S.F.

11/15/2025 10:00 AM

SECTION	COUNTY	TOTAL SHEETS	SHEET NO.
99-00124-01-PV	COLES	157	128

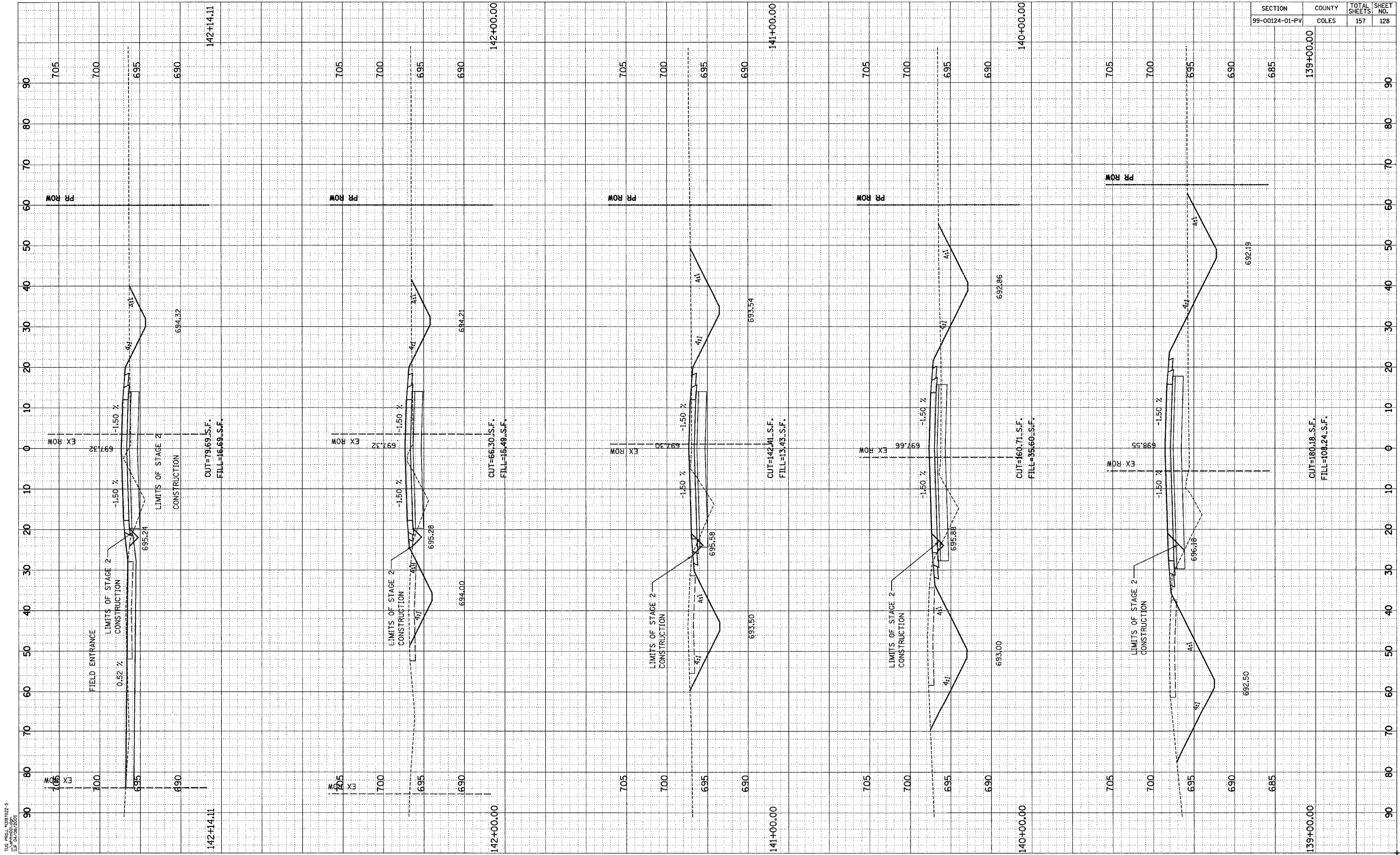

TUG PROJ #1587022-5
 CS #ATT00-006
 CS #V-00-205

SECTION	COUNTY	TOTAL SHEETS	SHEET NO.
99-00124-01-PV	COLES	157	129

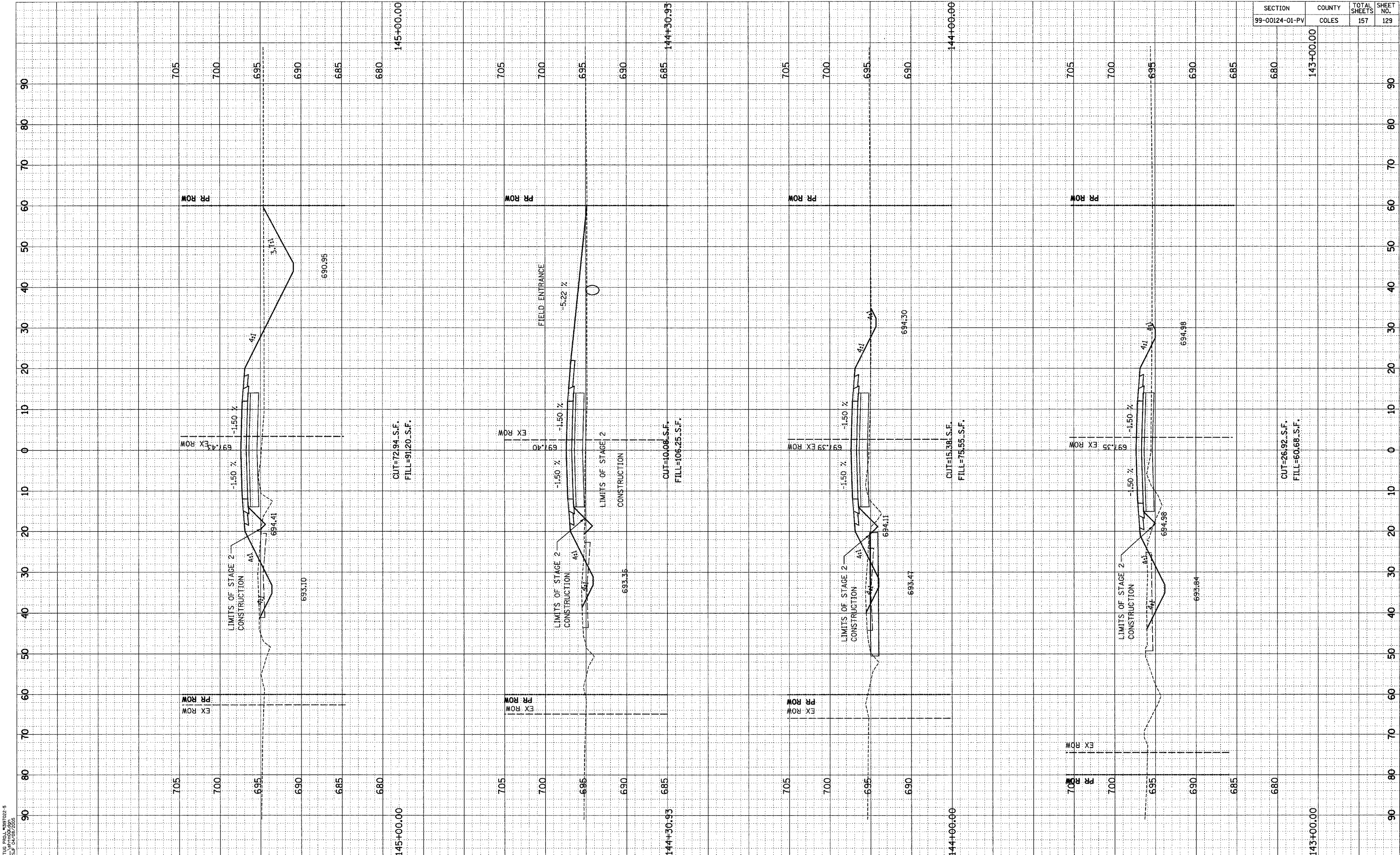

TUE PROJ: 991022-5
S.F. 04/08/2005

SECTION	COUNTY	TOTAL SHEETS	SHEET NO.
99-00124-01-PV	COLES	157	130

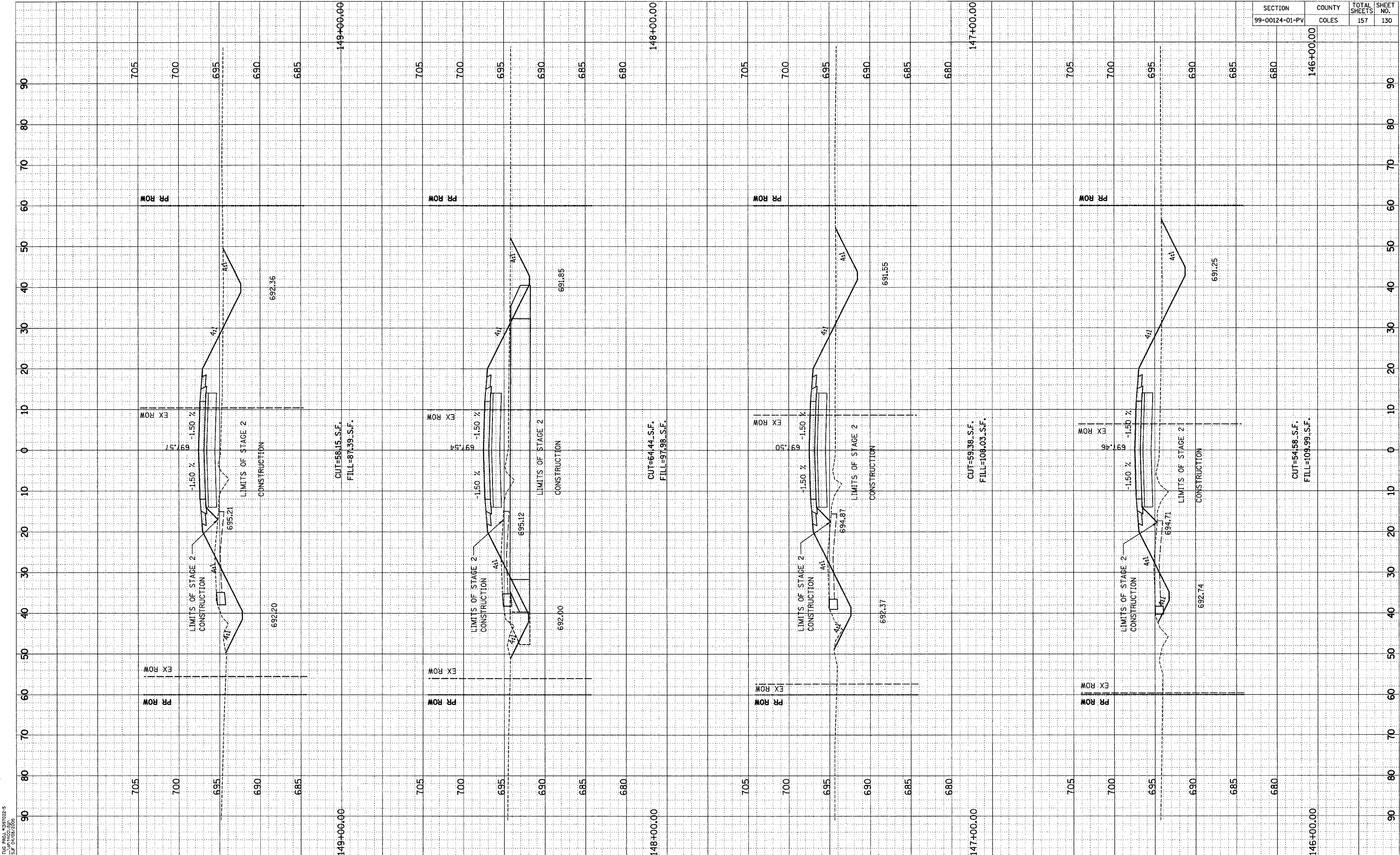

TUG PROJ. #19102E-5
S.F. 01/28/2006

SECTION	COUNTY	TOTAL SHEETS	SHEET NO.
99-00124-01-PV	COLES	157	131

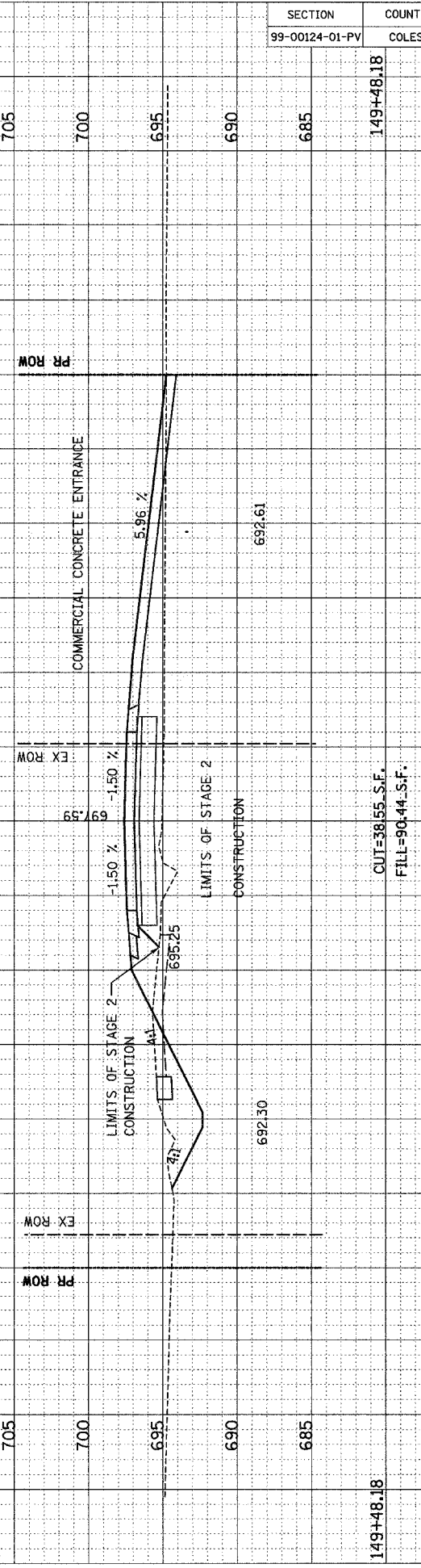
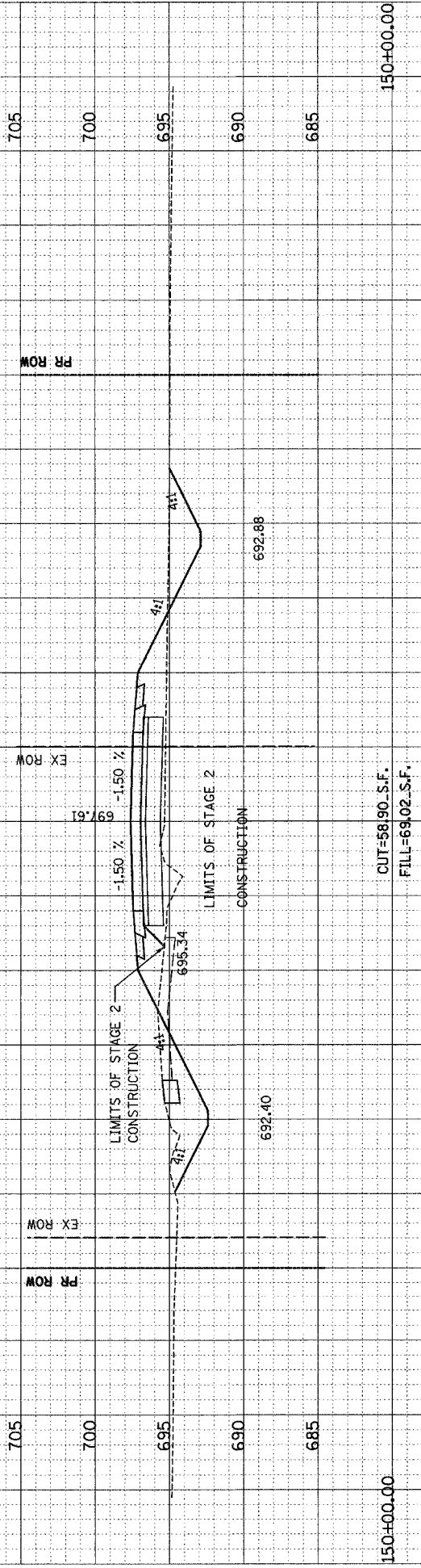
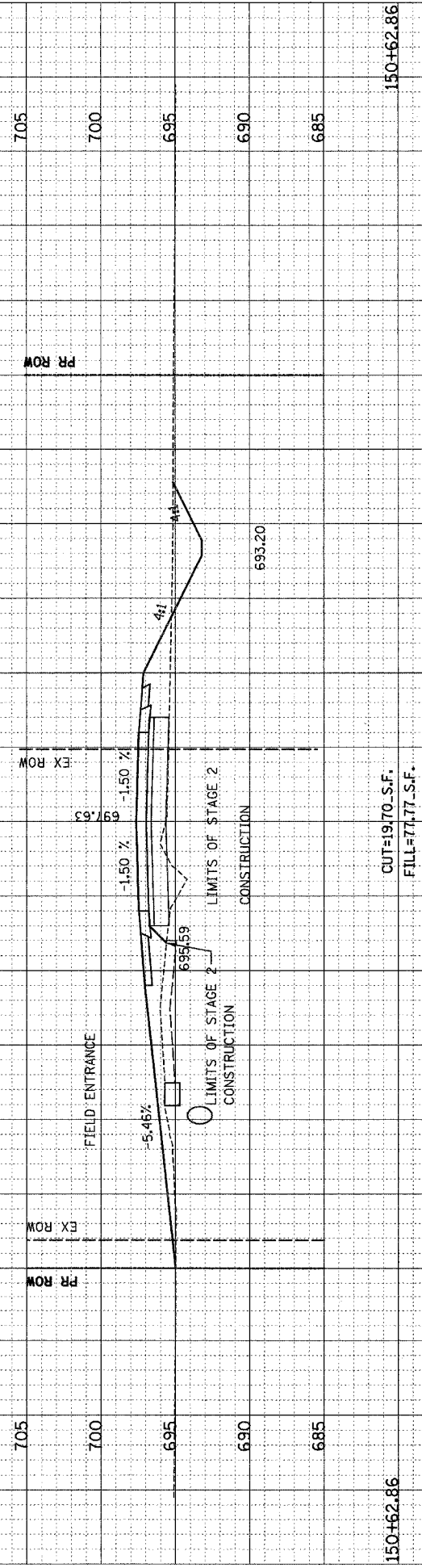
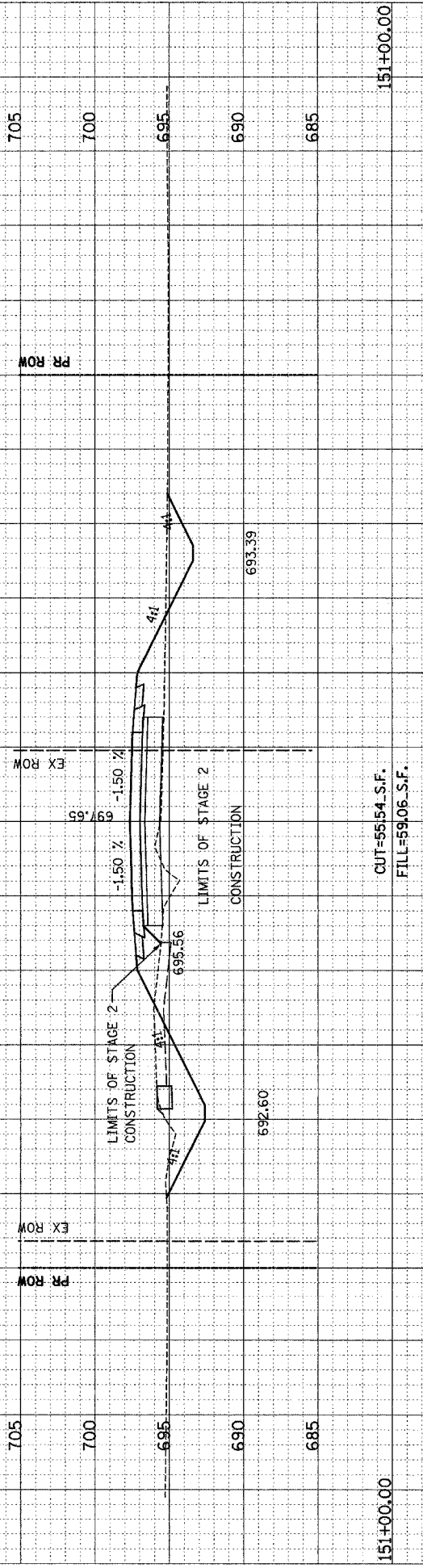

TUG PROJ. #38702-5
 DATE: 04/08/2005

SECTION	COUNTY	TOTAL SHEETS	SHEET NO.
99-00124-01-PV	COLES	157	132

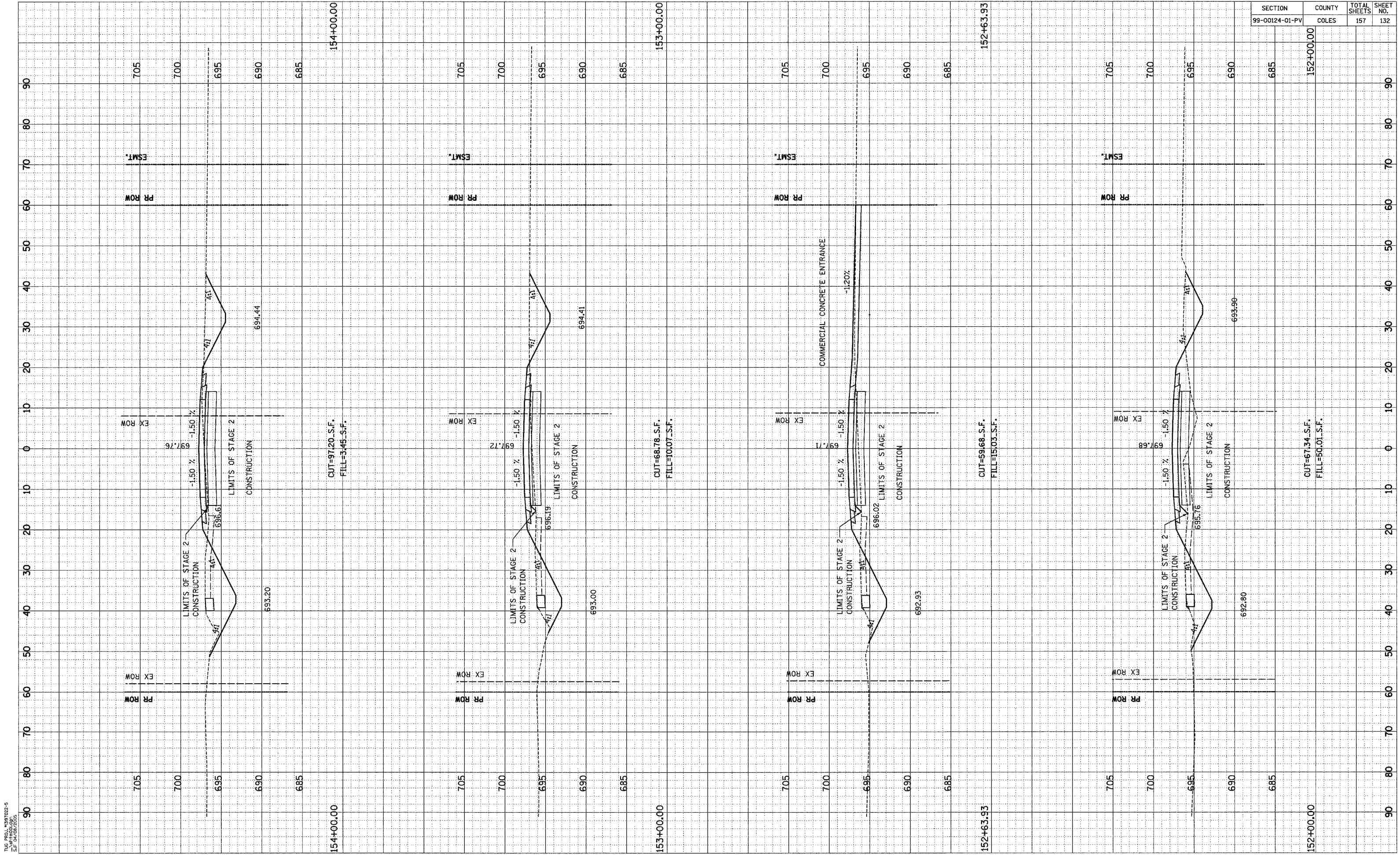

TUG PROJ. #367022-5
SHEET NO. 132
DATE 04/20/2005

SECTION	COUNTY	TOTAL SHEETS	SHEET NO.
99-00124-01-PV	COLES	157	133

TUG PROJ. #357022-5
DATE: 11/10/10
BY: JAC/BJD

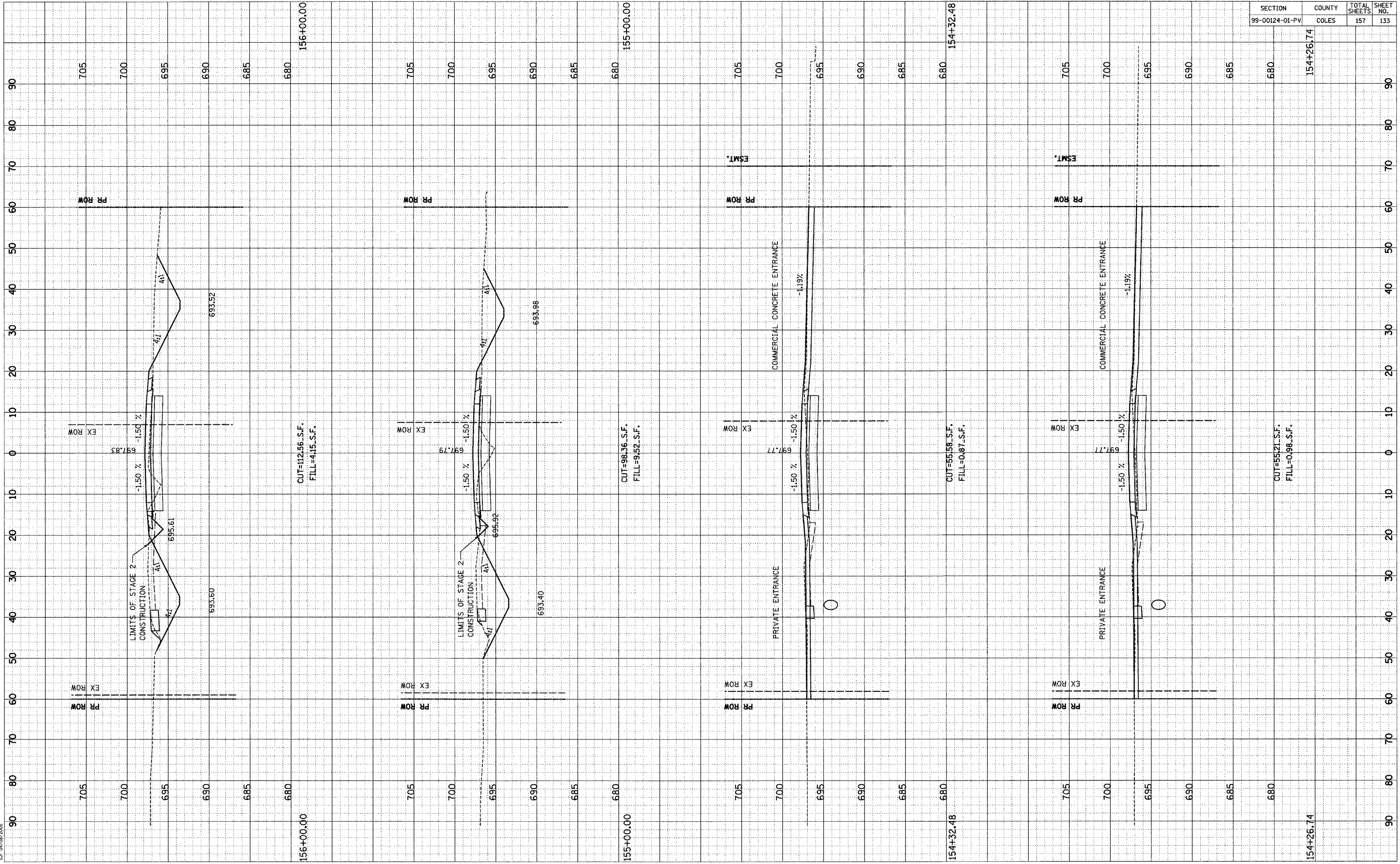

SECTION	COUNTY	TOTAL SHEETS	SHEET NO.
99-00124-01-PV	COLES	157	134

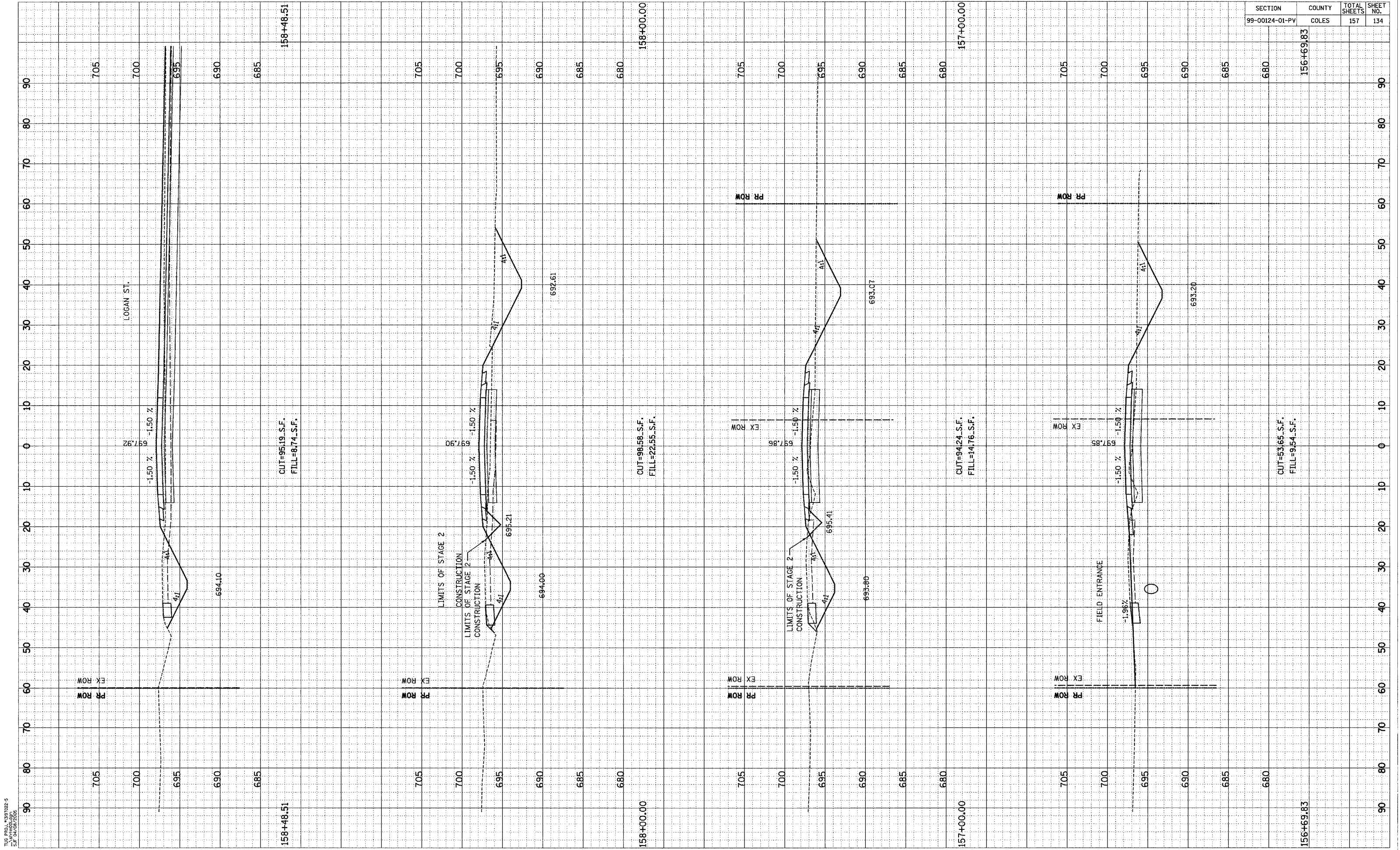

TUG PROJ. #367022-5
 C:\PROJECTS\99-00124-01-PV\99-00124-01-PV-134.DWG

SECTION	COUNTY	TOTAL SHEETS	SHEET NO.
99-00124-01-PV	COLES	157	135

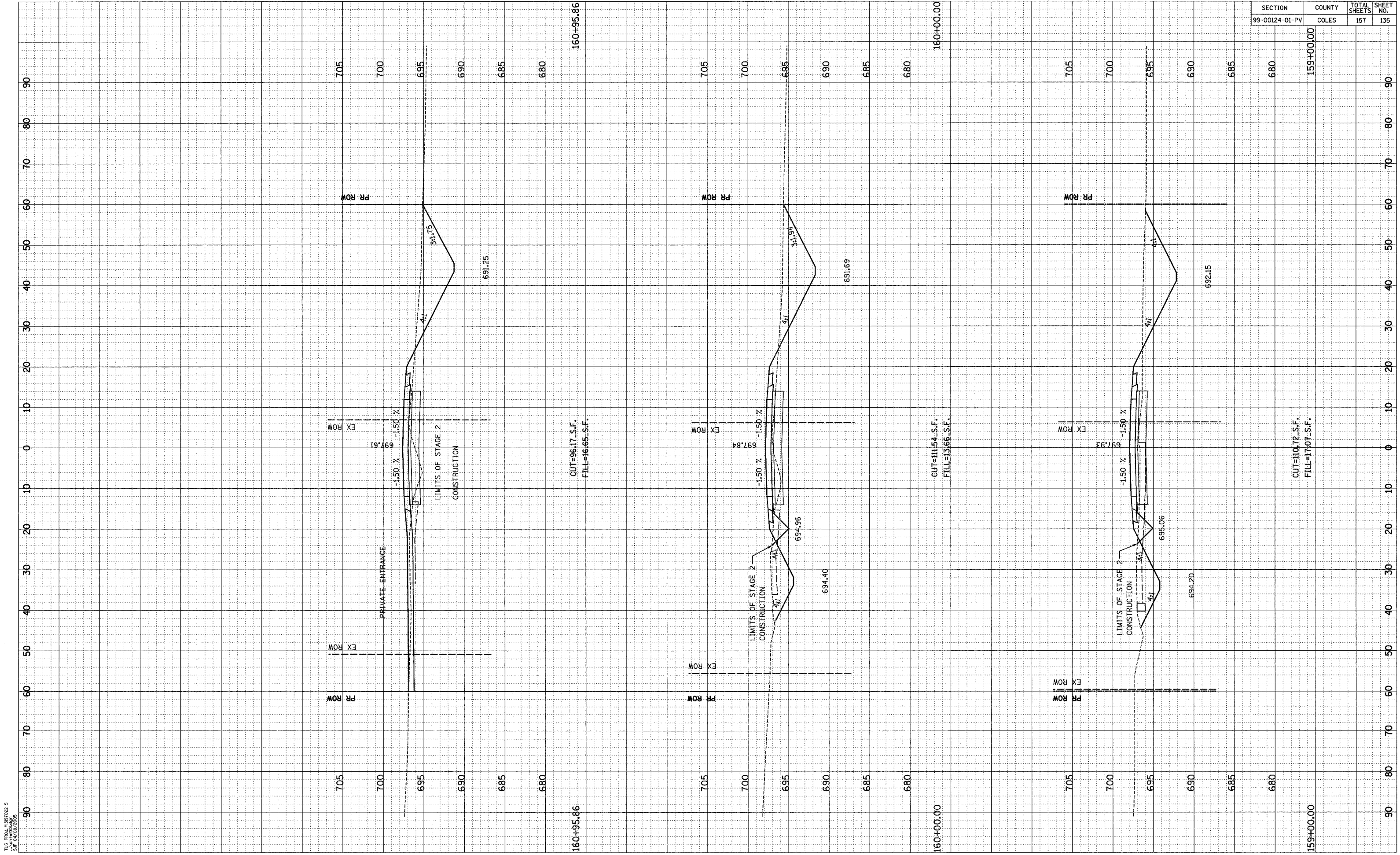

TUG PROJ. #387022-5
 3/11/2009 4:56
 3/11/2009 2:55

SECTION	COUNTY	TOTAL SHEETS	SHEET NO.
99-00124-01-PV	COLES	157	136

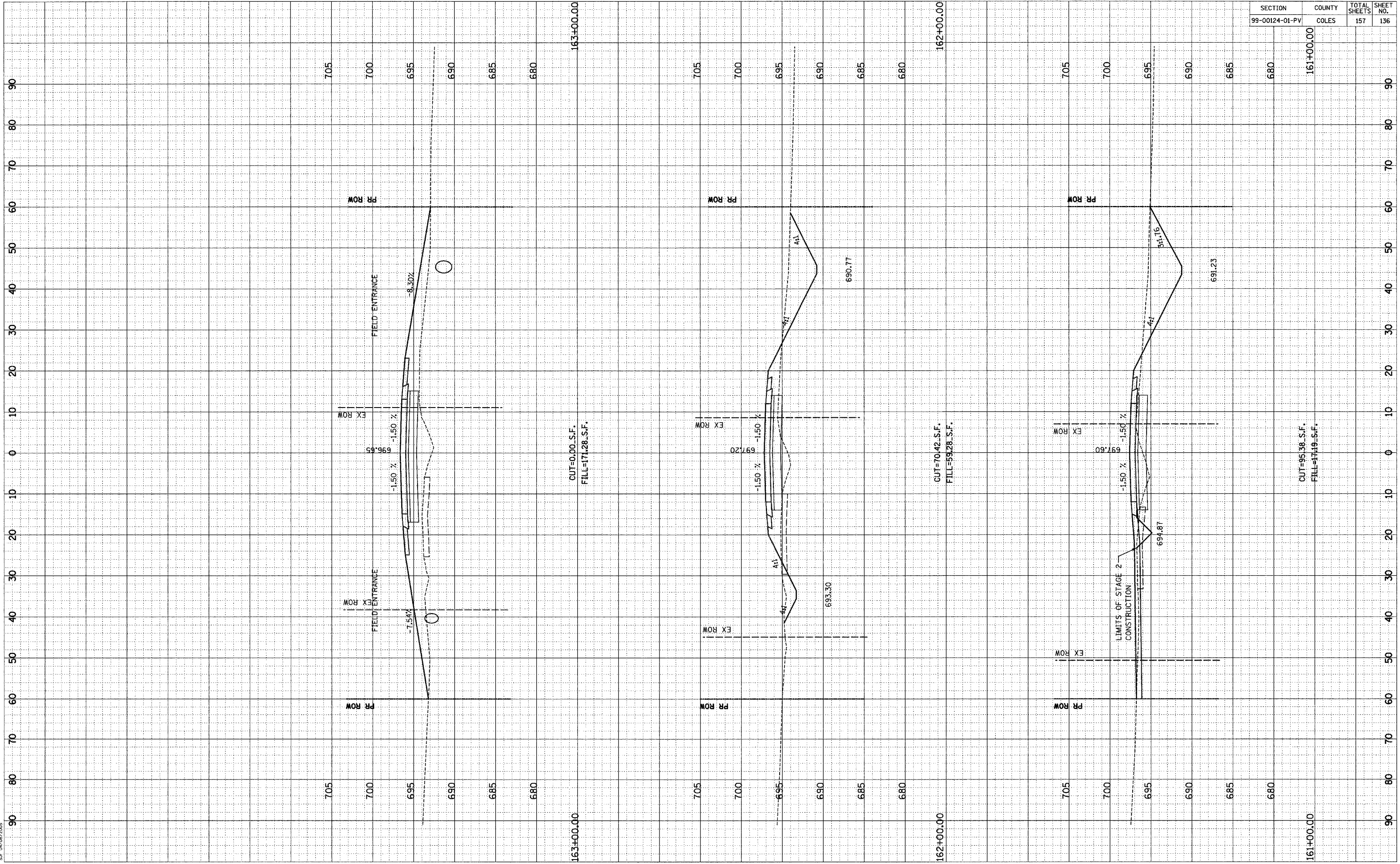

TUG PROJ. #387022-5
 DATE: 01/08/2009
 BY: JWB/2355

SECTION	COUNTY	TOTAL SHEETS	SHEET NO.
99-00124-01-PV	COLES	157	137

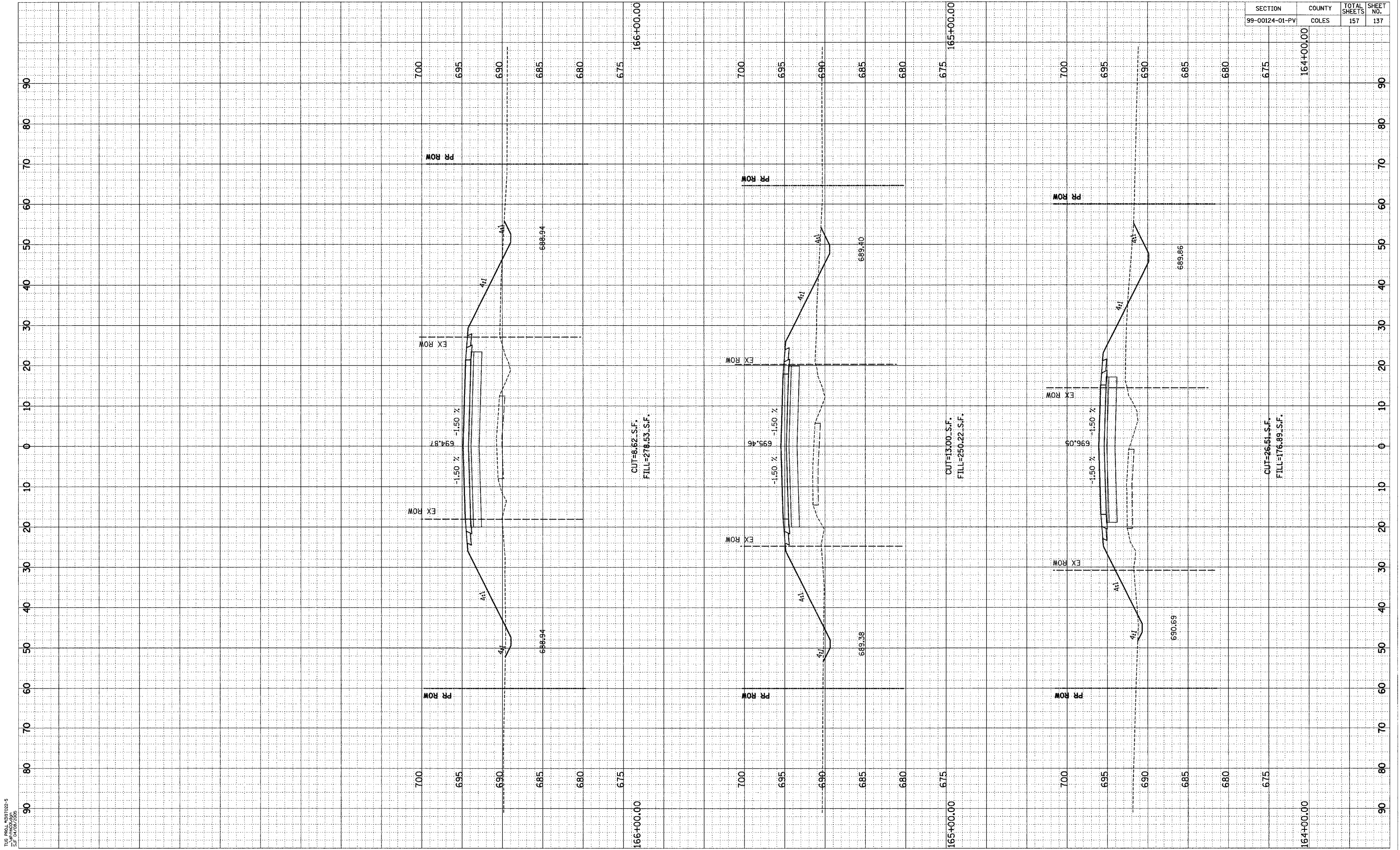

TUG PROJ #951092-5
 DATE 07/20/2009
 BY 04/20/2009

SECTION	COUNTY	TOTAL SHEETS	SHEET NO.
99-00124-01-PV	COLES	157	138

TUG PREL. #13197022-5
 DATE: 11/01/2005
 BY: JPH/25/2005

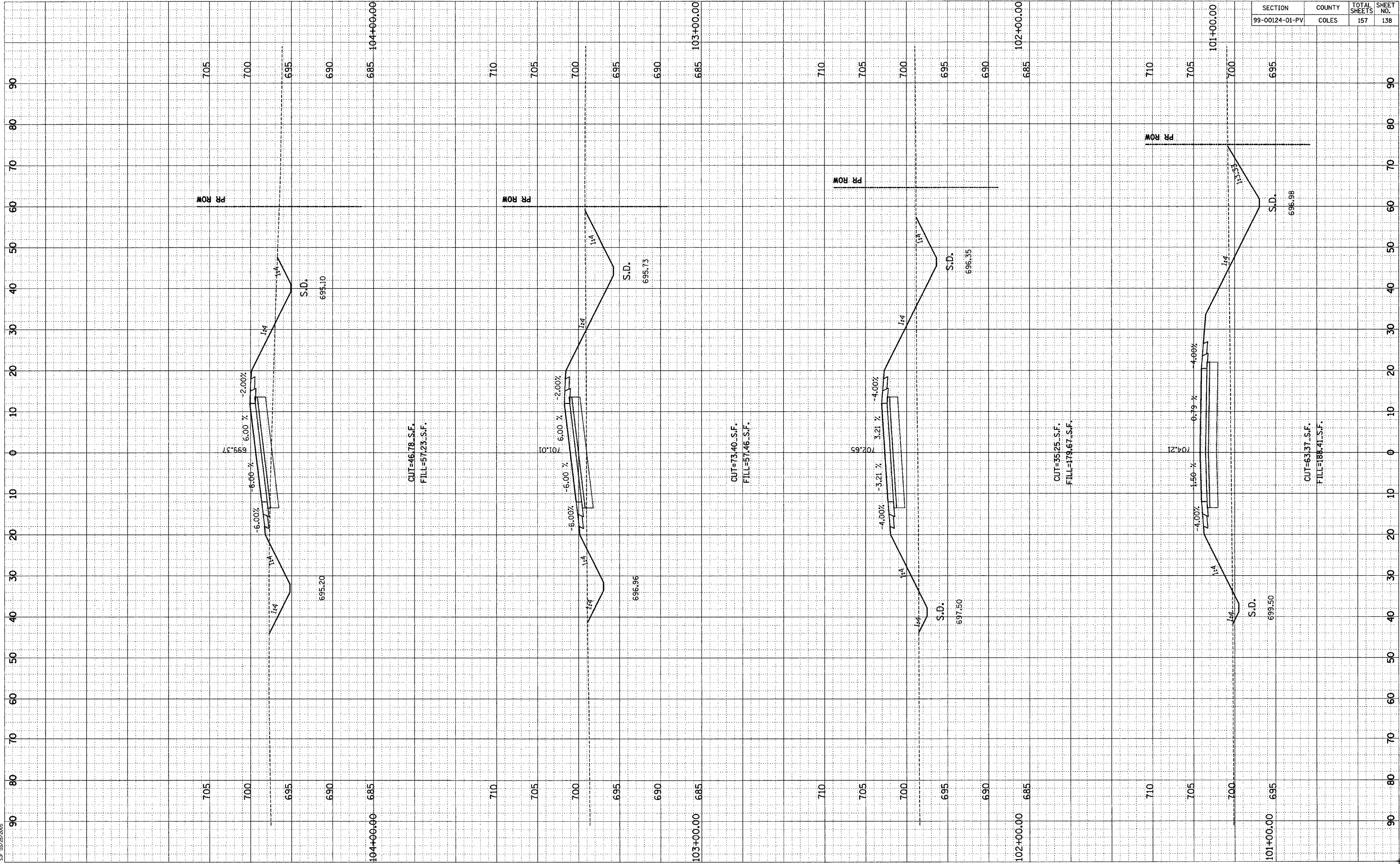

SECTION	COUNTY	TOTAL SHEETS	SHEET NO.
99-00124-01-PV	COLES	157	139

TUC PROJ. #13197022-5
DATE: 01/01/05
CIP: 01/25/05

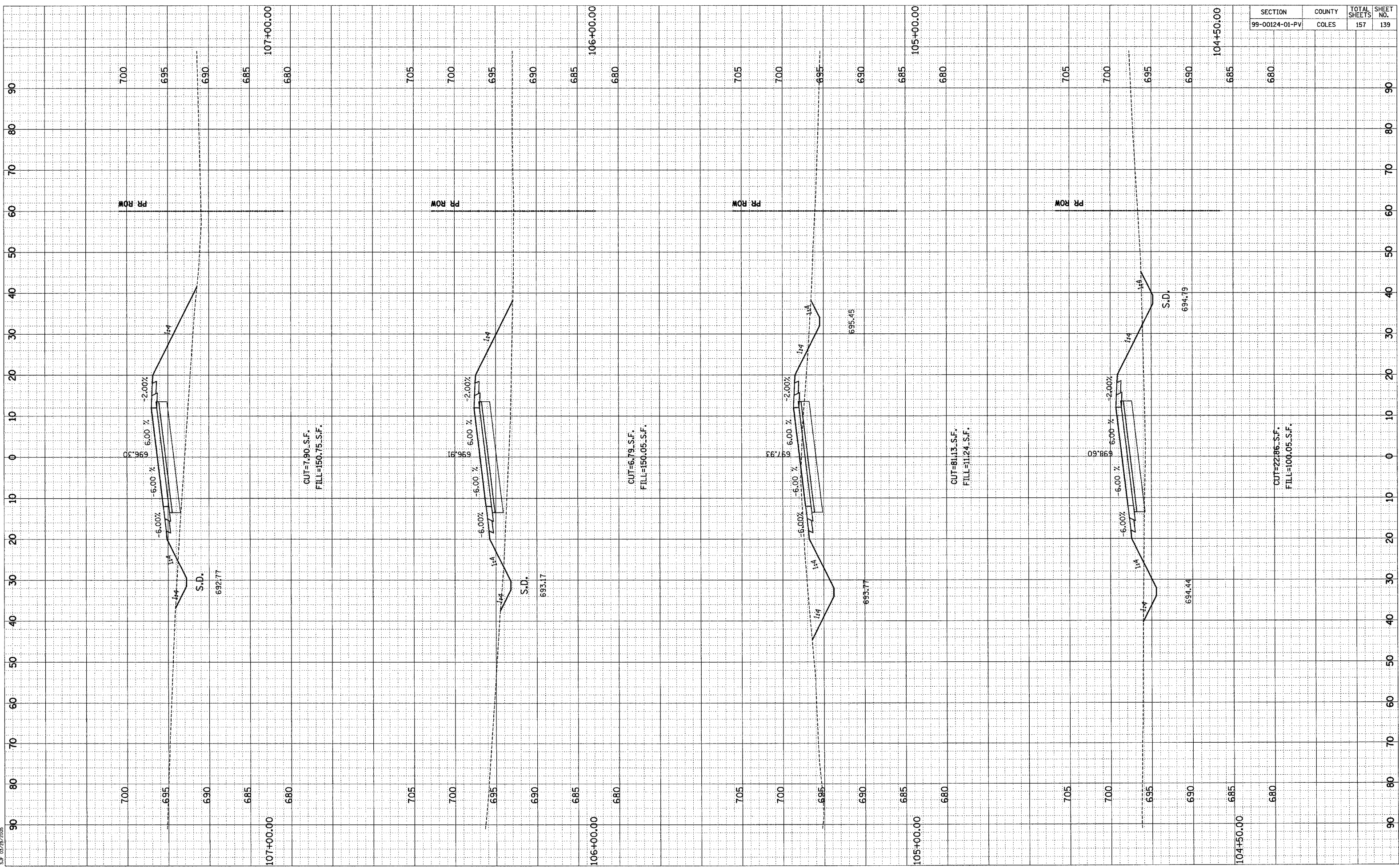

SECTION	COUNTY	TOTAL SHEETS	SHEET NO.
99-00124-01-PV	COLES	157	140

TUG PRL #1317022-5
 11/11/2010 09:05
 S.F. 03/25/2005

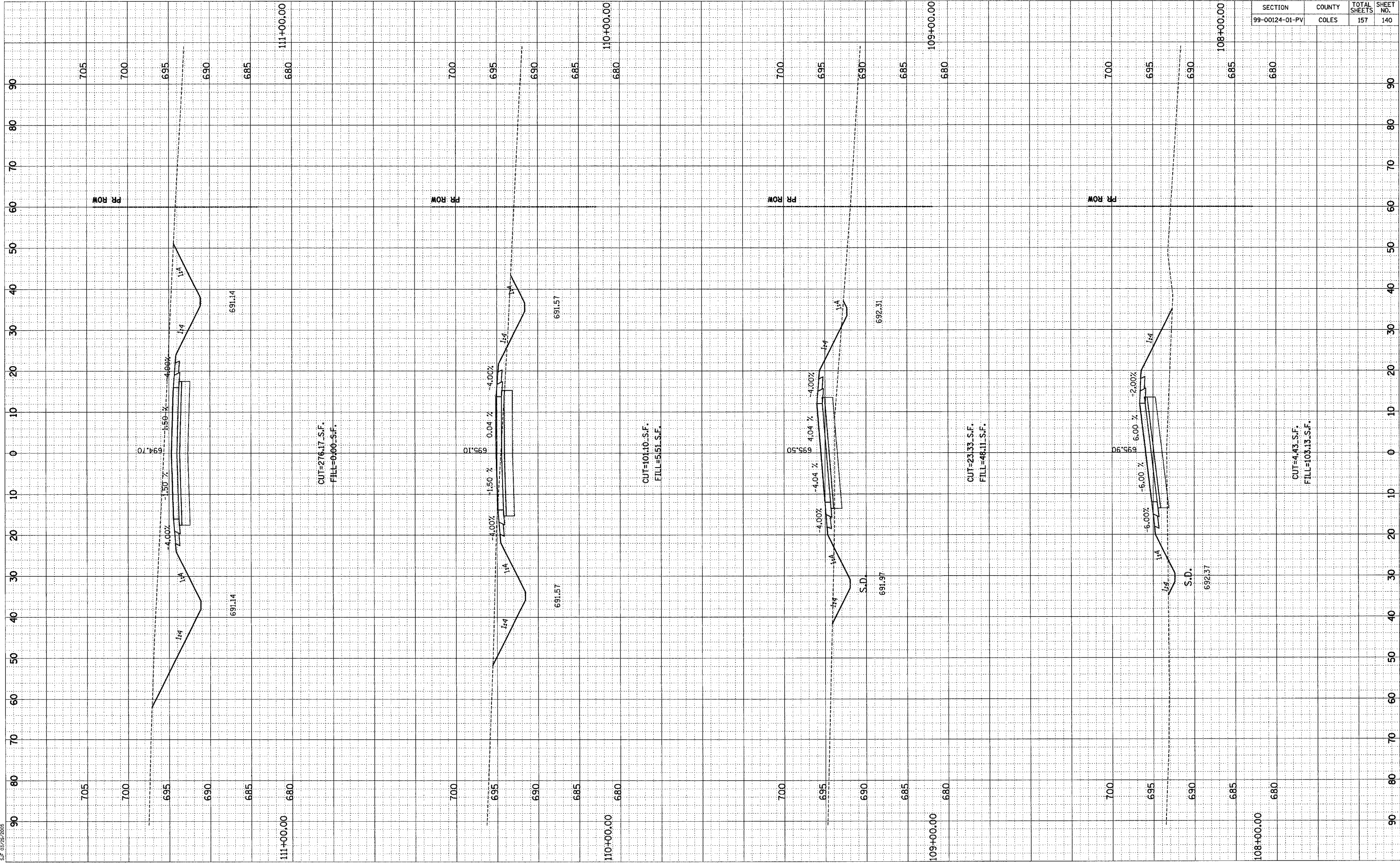

SECTION	COUNTY	TOTAL SHEETS	SHEET NO.
99-00124-01-PV	COLES	157	141

TIG PROJ. #1318702-5
 DATE: 11/01/00
 BY: JVS/2005

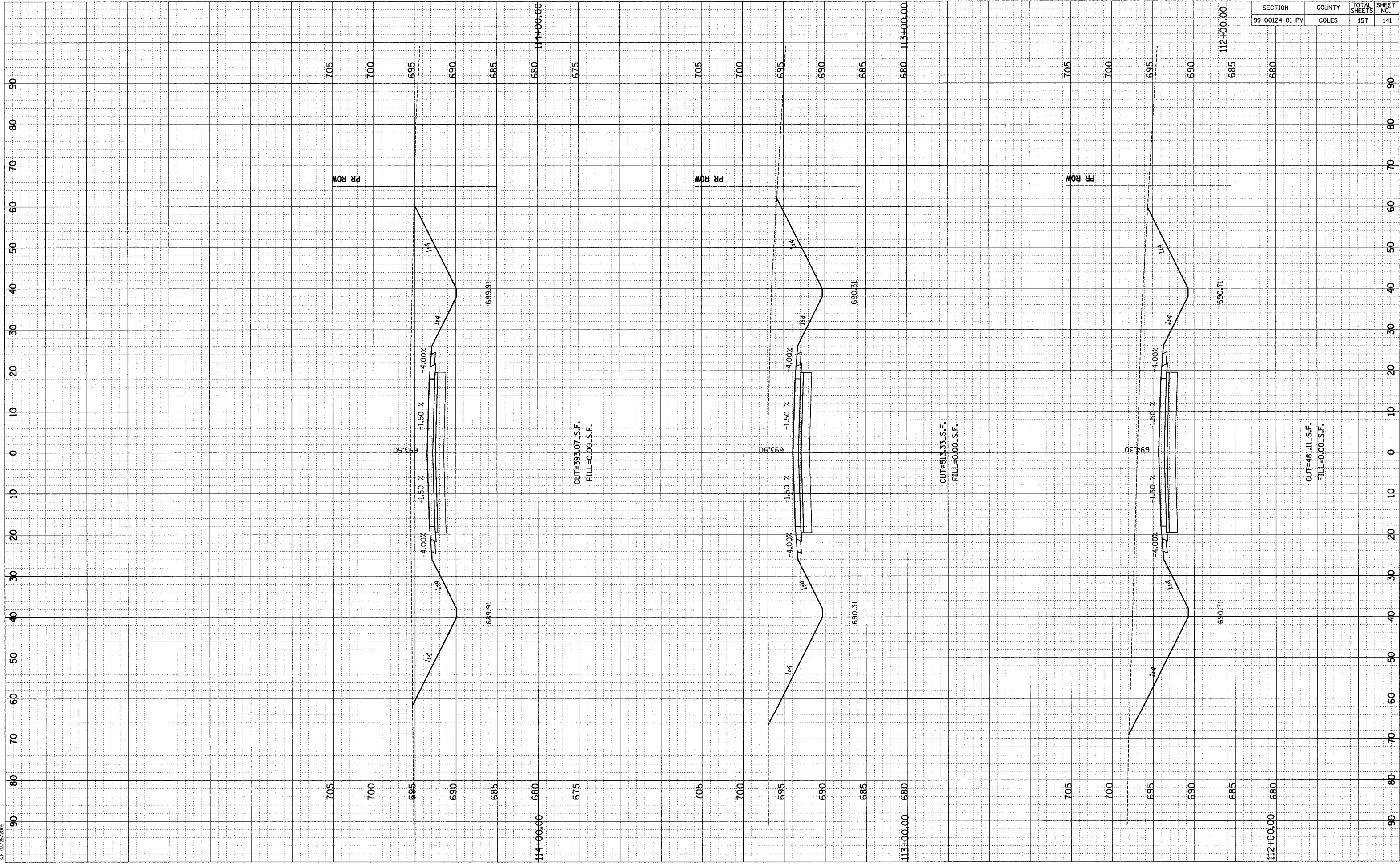

SECTION	COUNTY	TOTAL SHEETS	SHEET NO.
99-00124-01-PV	COLES	157	142

TUG PROL #13171022-5
 DATE 11/01/2010
 BY 2010/12/23/2005

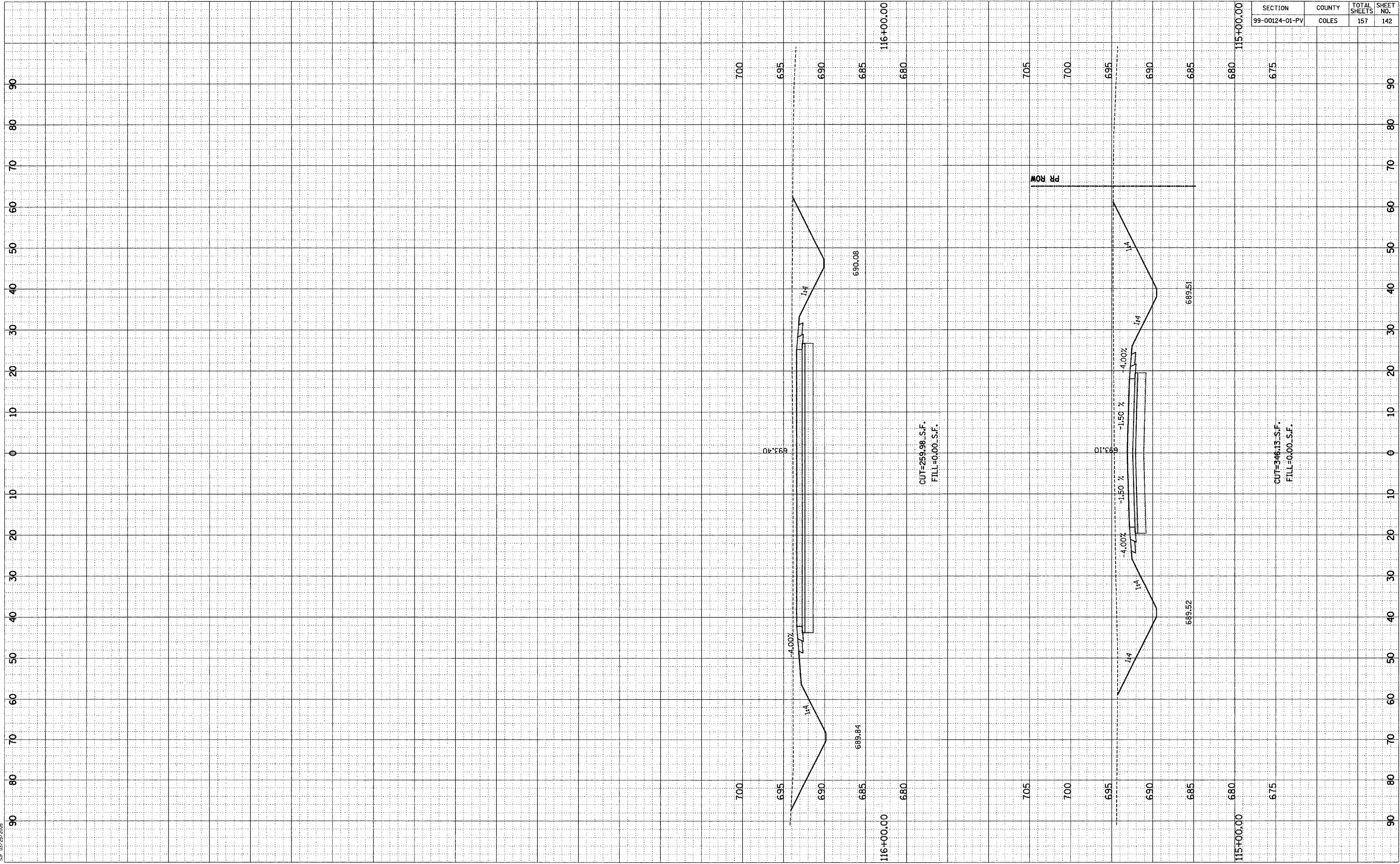

SECTION	COUNTY	TOTAL SHEETS	SHEET NO.
99-00124-01-PV	COLES	157	143

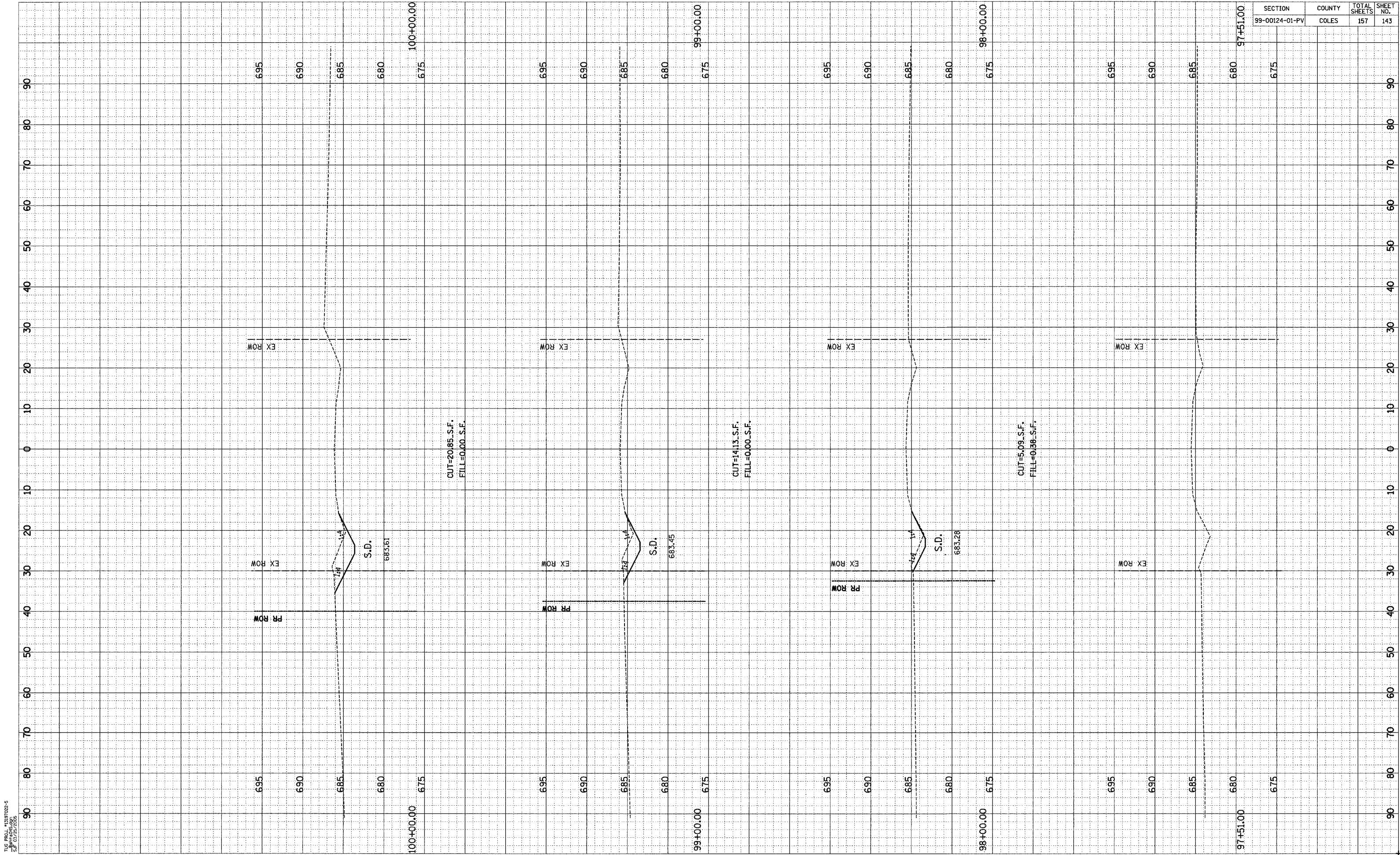

TUG PROJ. #131702-5
 DATE: 05/14/09
 SHEET: 143 OF 157

SECTION	COUNTY	TOTAL SHEETS	SHEET NO.
99-00124-01-PV	COLES	157	144

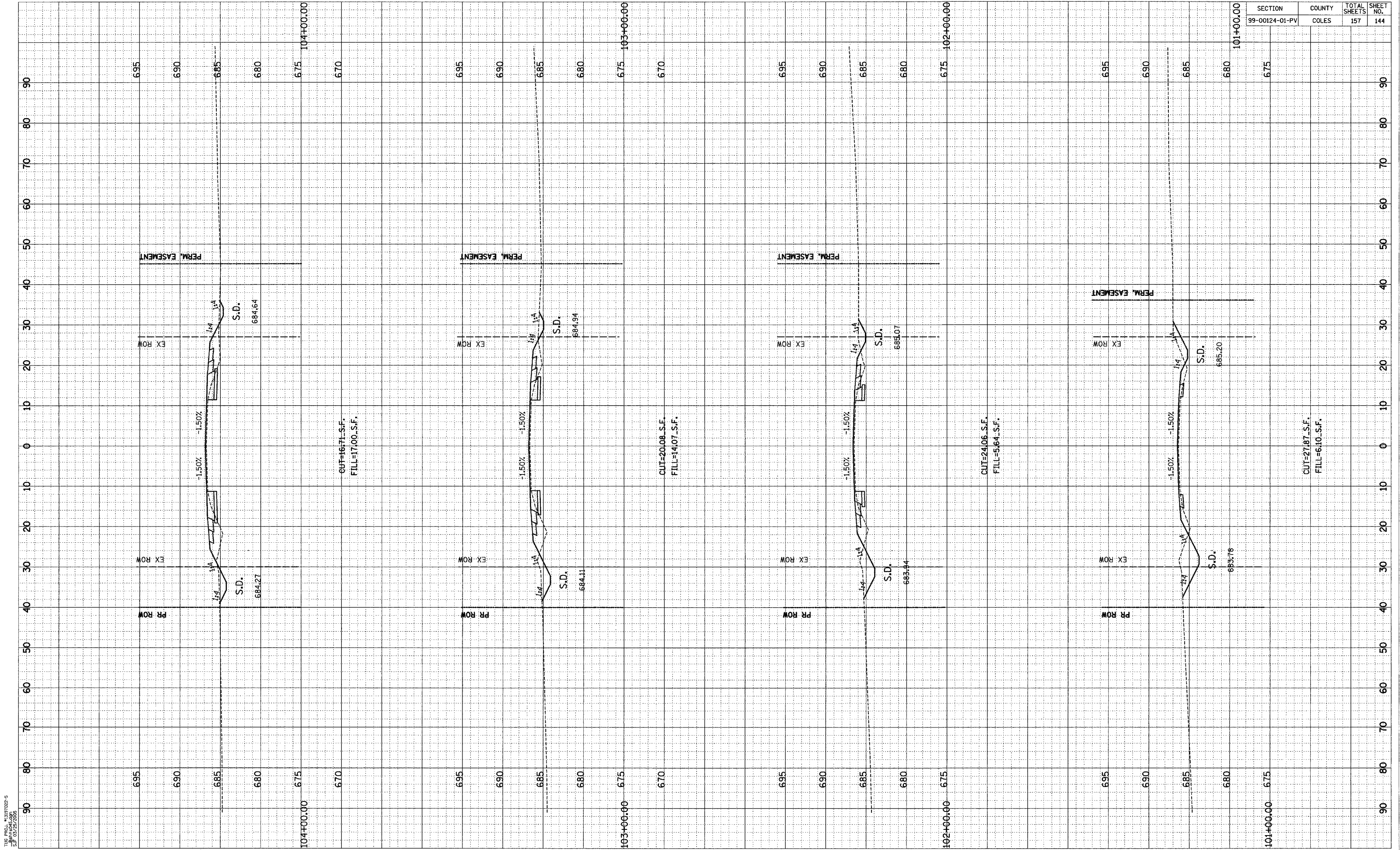

TUG PROJ. #3197022-5
 DATE PLOT 04/06/06
 3:53:25 PM

SECTION	COUNTY	TOTAL SHEETS	SHEET NO.
99-00124-01-PV	COLES	157	145

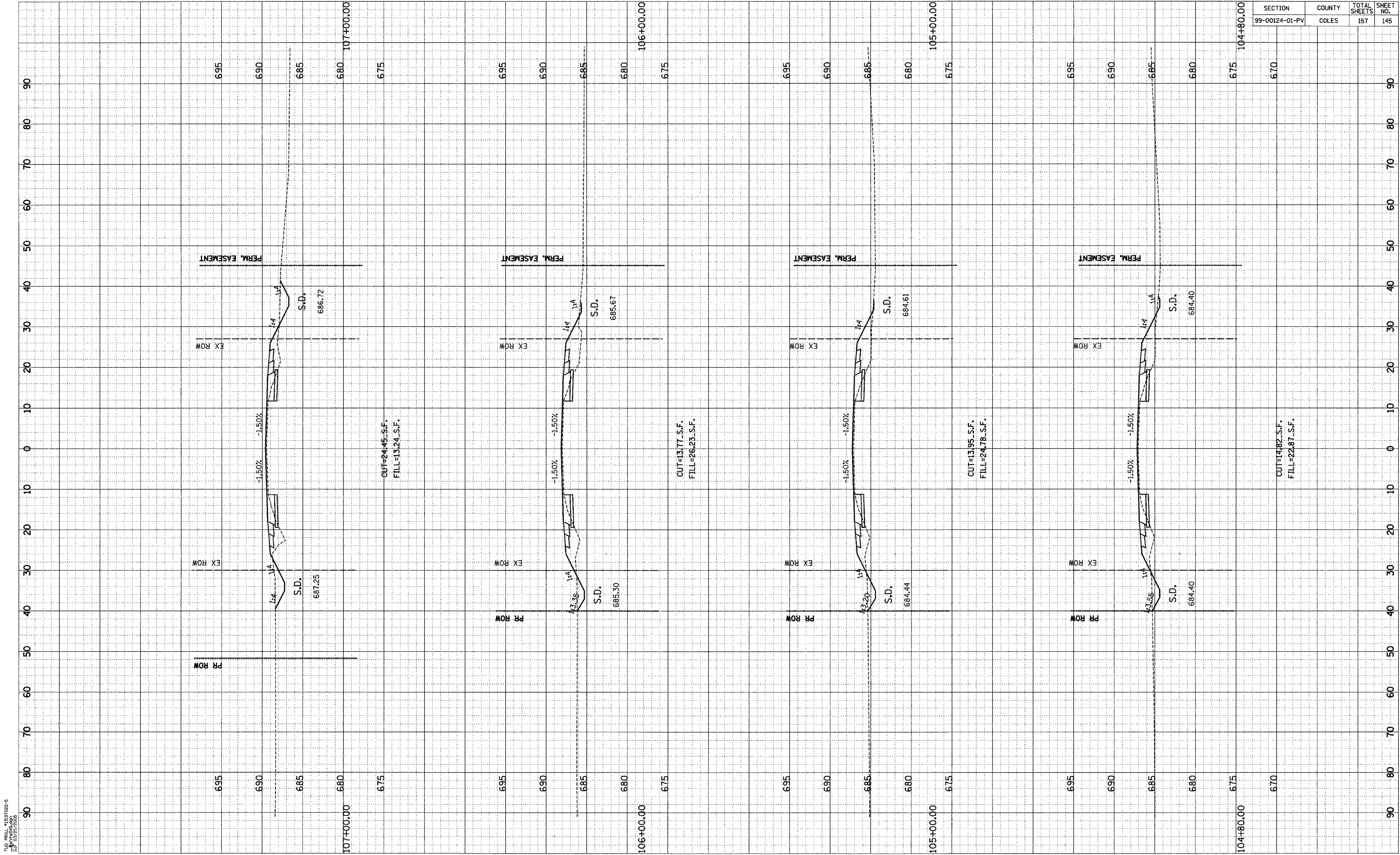

TUG PROJ. #1317022-5
 DATE: 11/14/2017
 11:52:53 AM

SECTION	COUNTY	TOTAL SHEETS	SHEET NO.
99-00124-01-PV	COLES	157	146

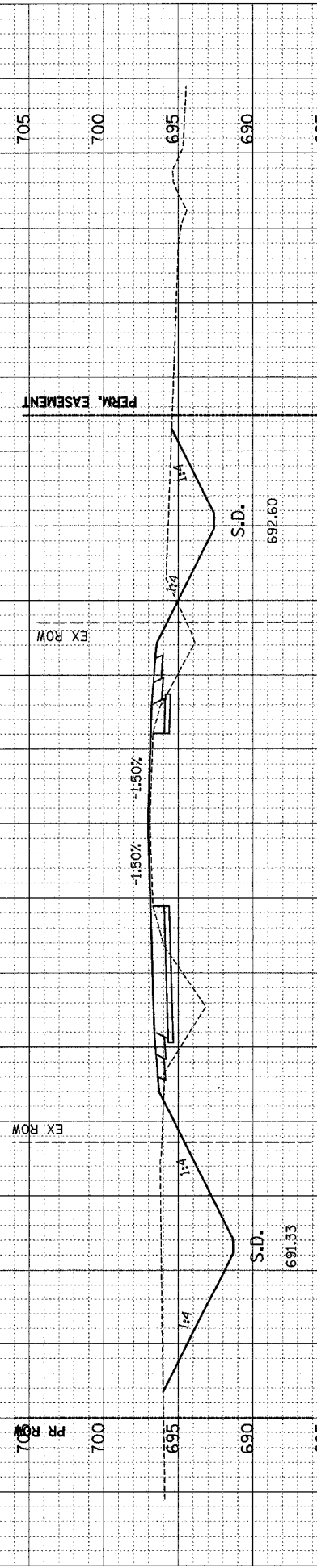

CUT=150.36 S.F.
FILL=34.95 S.F.

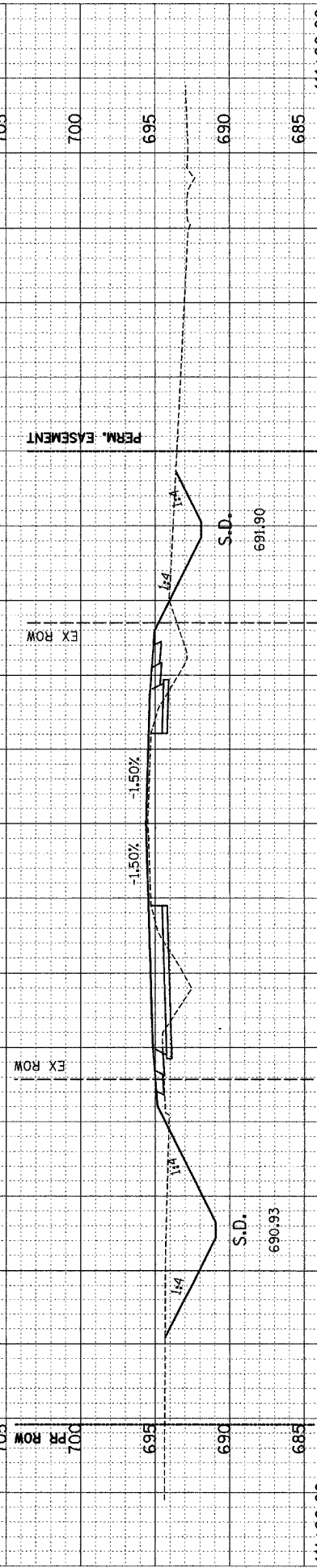

CUT=78.86 S.F.
FILL=23.73 S.F.

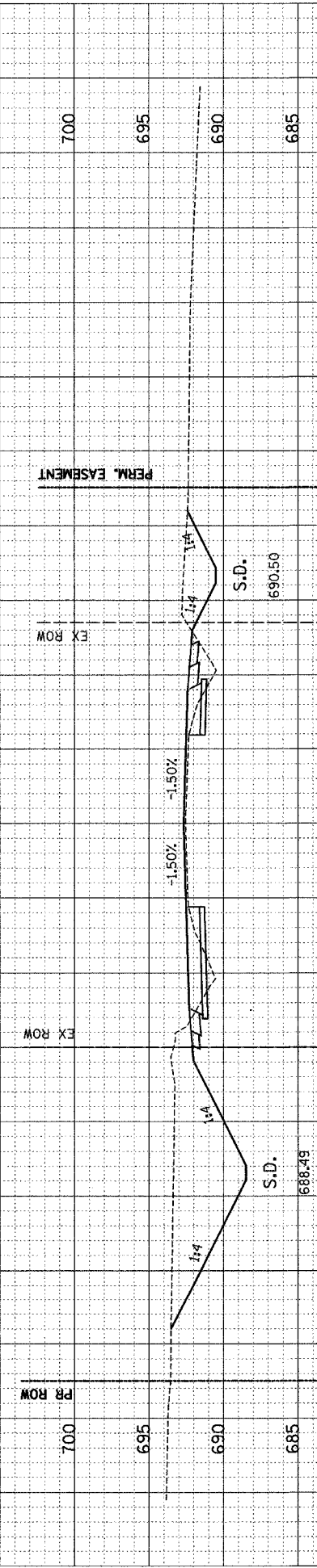

CUT=140.91 S.F.
FILL=5.79 S.F.

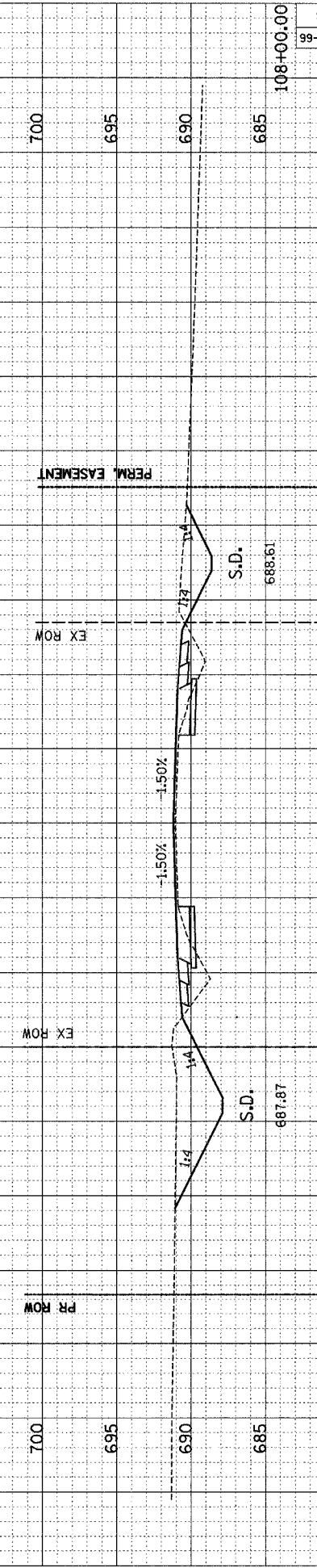

CUT=73.39 S.F.
FILL=12.11 S.F.

THIS DRAWING IS THE PROPERTY OF THE UPCHURCH GROUP, INC. AND IS NOT TO BE REPRODUCED OR TRANSMITTED IN ANY FORM OR BY ANY MEANS, ELECTRONIC OR MECHANICAL, INCLUDING PHOTOCOPYING, RECORDING, OR BY ANY INFORMATION STORAGE AND RETRIEVAL SYSTEM.

SECTION	COUNTY	TOTAL SHEETS	SHEET NO.
99-00124-01-PV	COLES	157	147

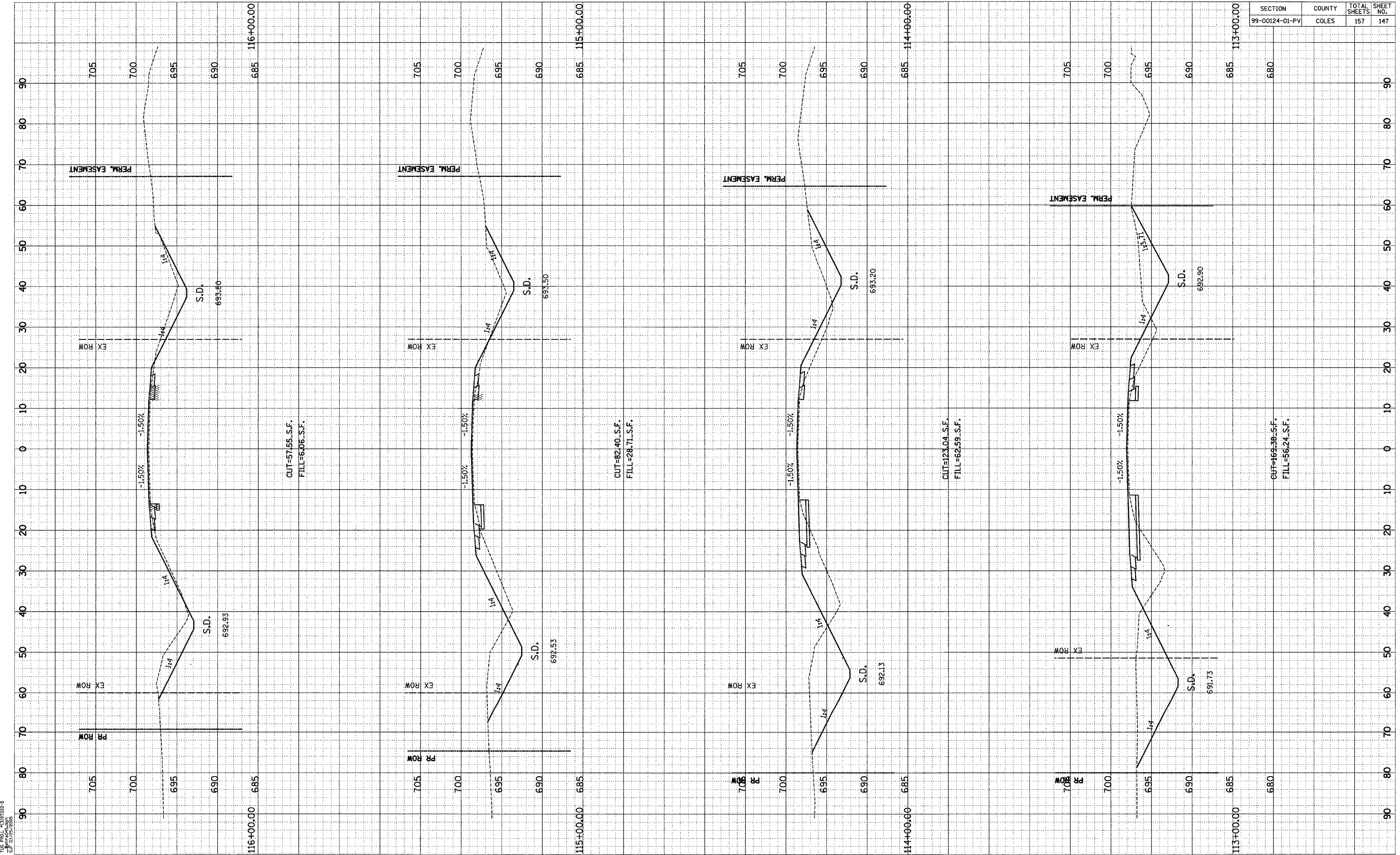

116+00.00 115+00.00 114+00.00 113+00.00

SECTION	COUNTY	TOTAL SHEETS	SHEET NO.
99-00124-01-PV	COLES	157	148

TIG PROJ. #1397022-5
DATE PLOTTED: 03/23/2005

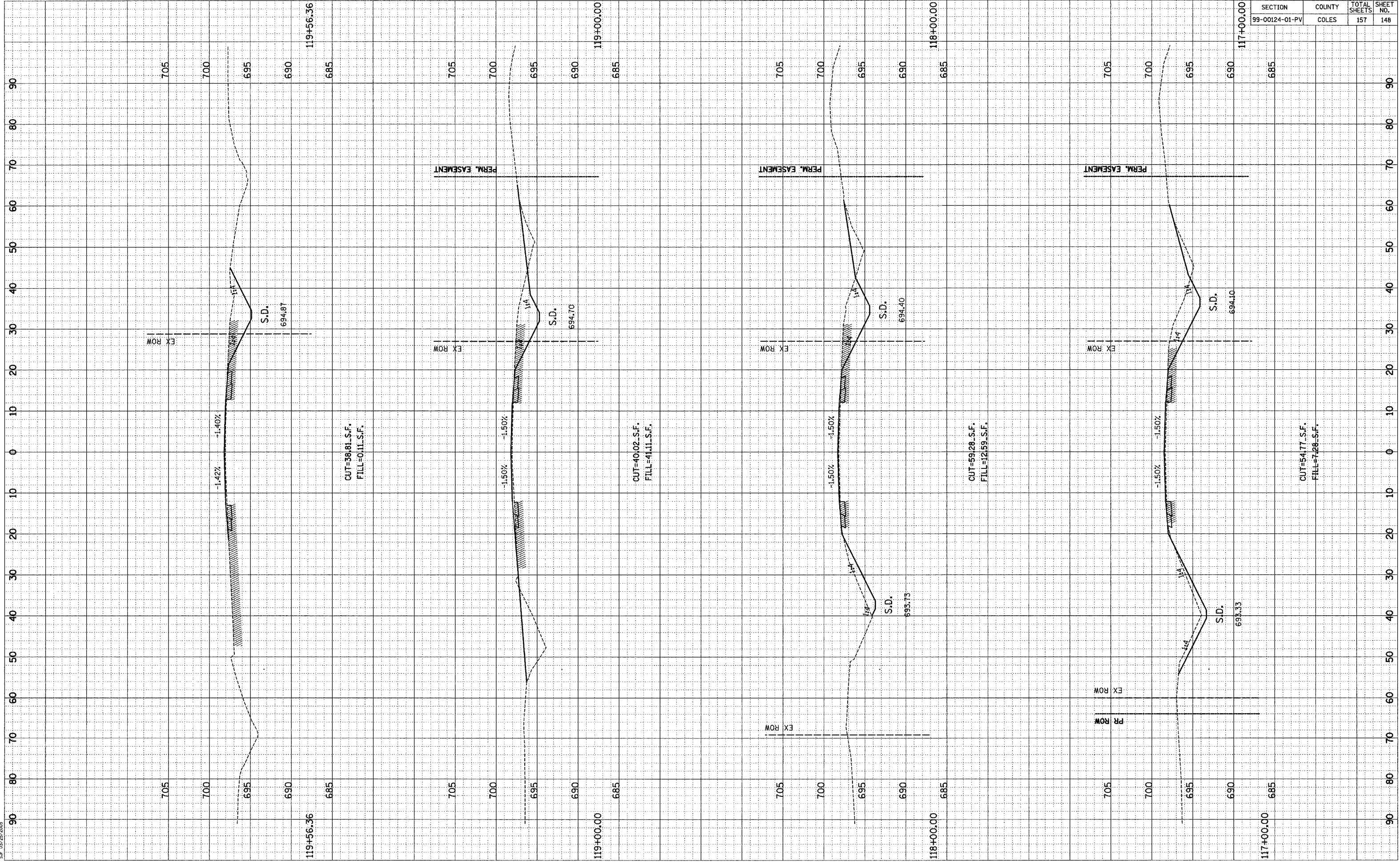

SECTION	COUNTY	TOTAL SHEETS	SHEET NO.
99-00124-01-PV	COLES	157	149

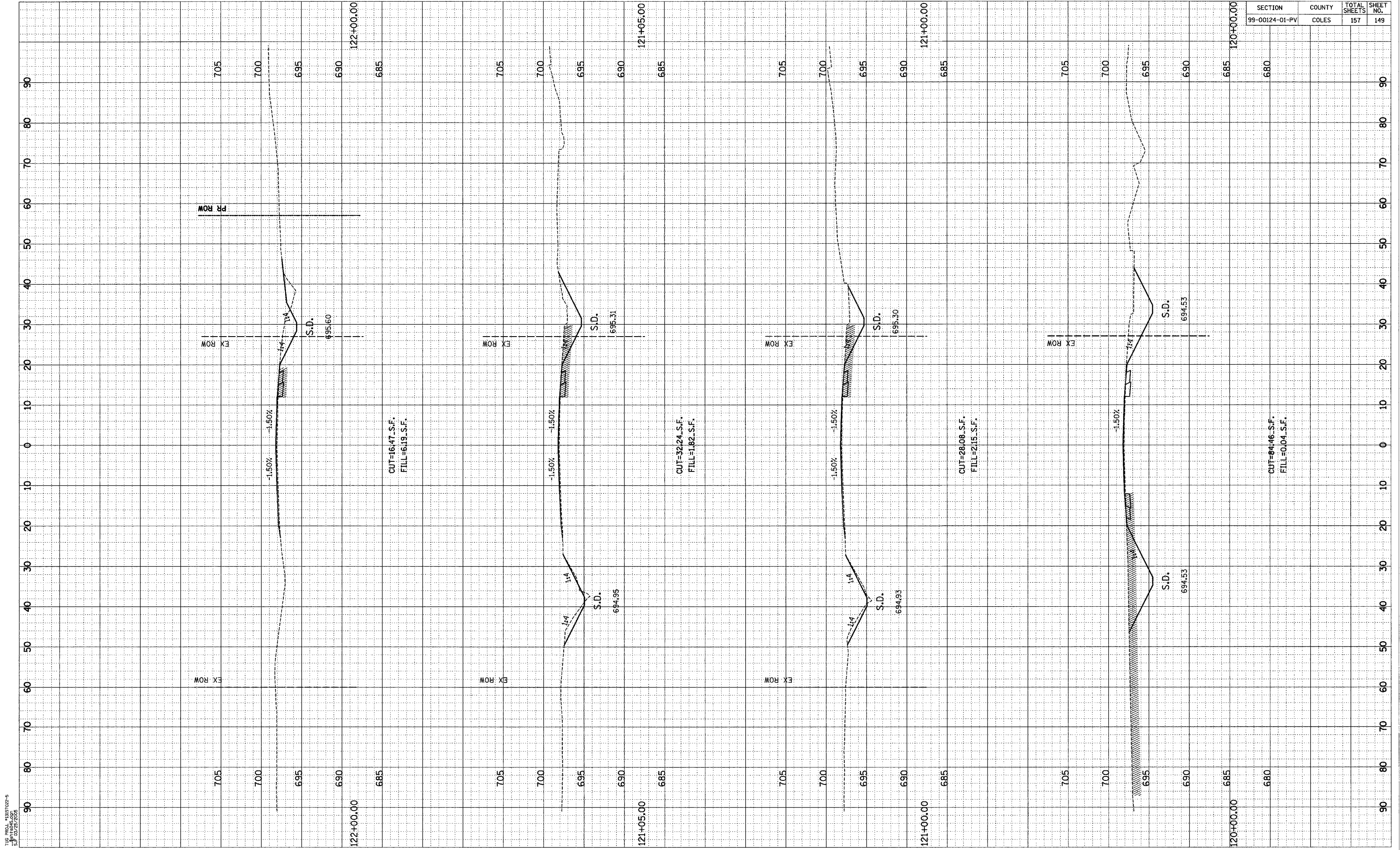

TUG PRL #131022-5
 DATE PLOTTED 05/25/2005

SECTION	COUNTY	TOTAL SHEETS	SHEET NO.
99-00124-01-PV	COLES	157	150

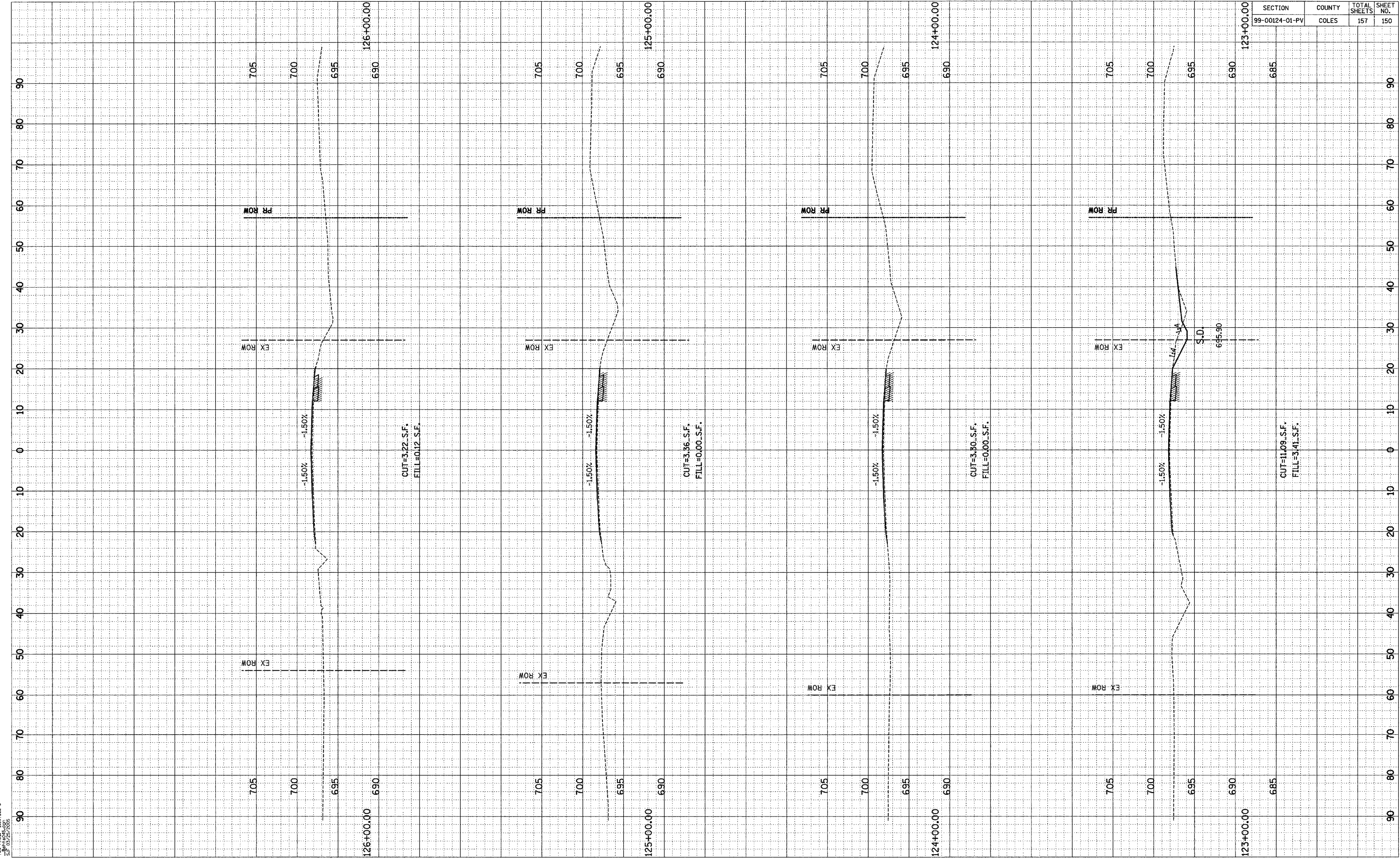

TUG PLOL #13191022-5
SHEET 150 OF 157
DATE 03/25/2005

SECTION	COUNTY	TOTAL SHEETS	SHEET NO.
99-00124-01-PV	COLES	157	151

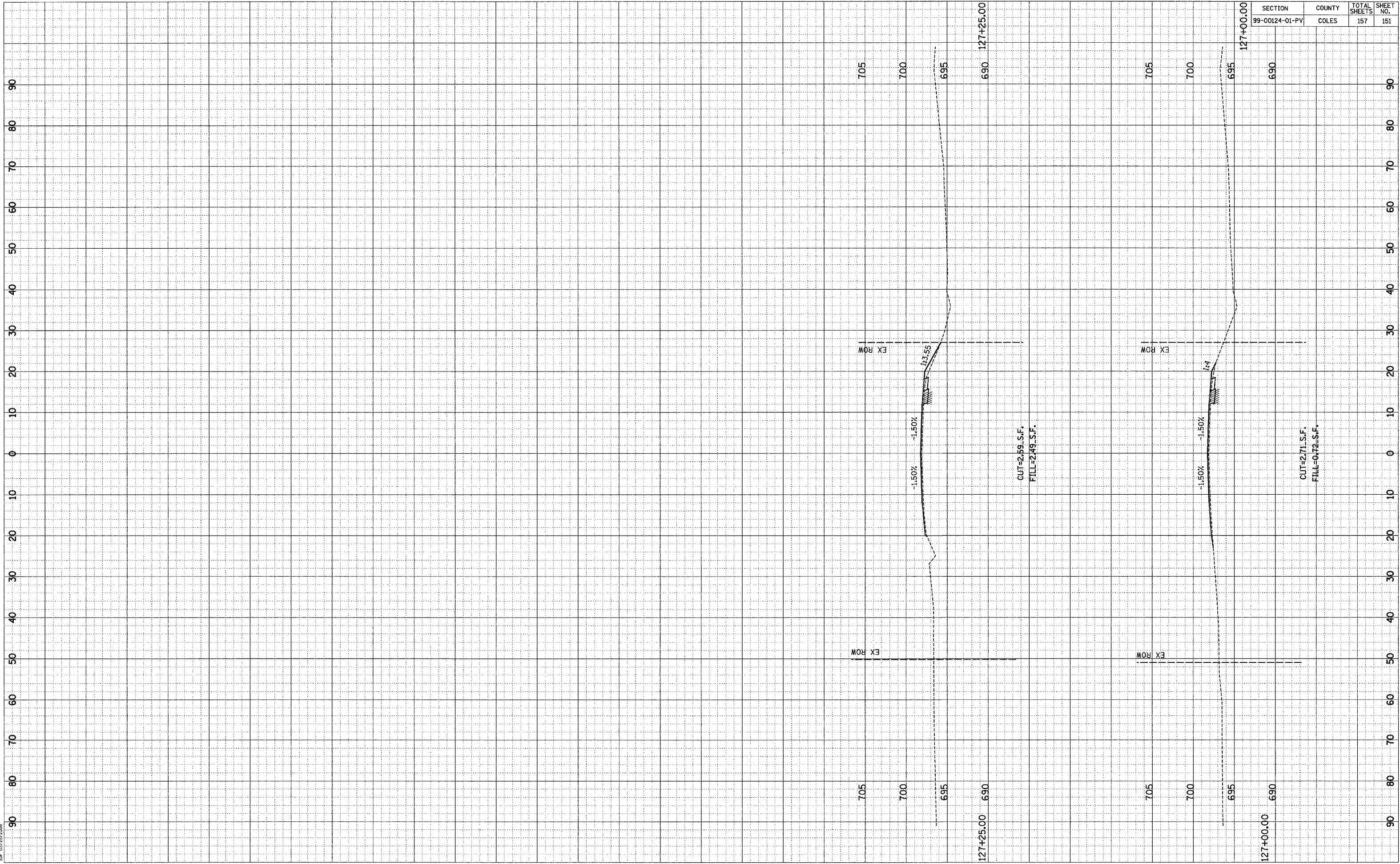

TUG PRL #1317025-5
DATE: 12/15/2009
SCALE: AS SHOWN

SECTION	COUNTY	TOTAL SHEETS	SHEET NO.
99-00124-01-PV	COLES	157	152

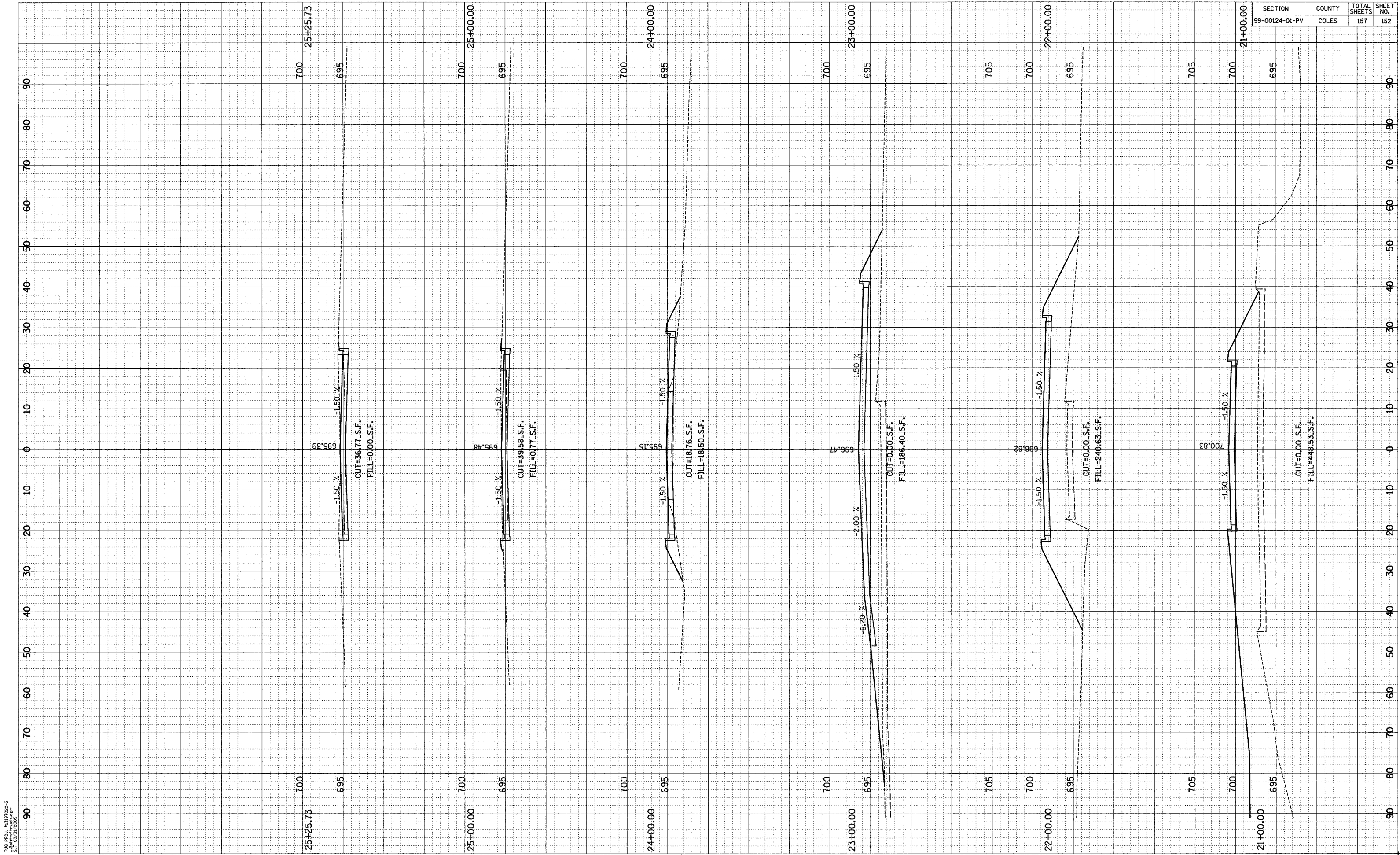

TUG PROJ. #1319782-5
 DATE: 03/27/2009

SECTION	COUNTY	TOTAL SHEETS	SHEET NO.
99-00124-01-PV	COLES	157	153

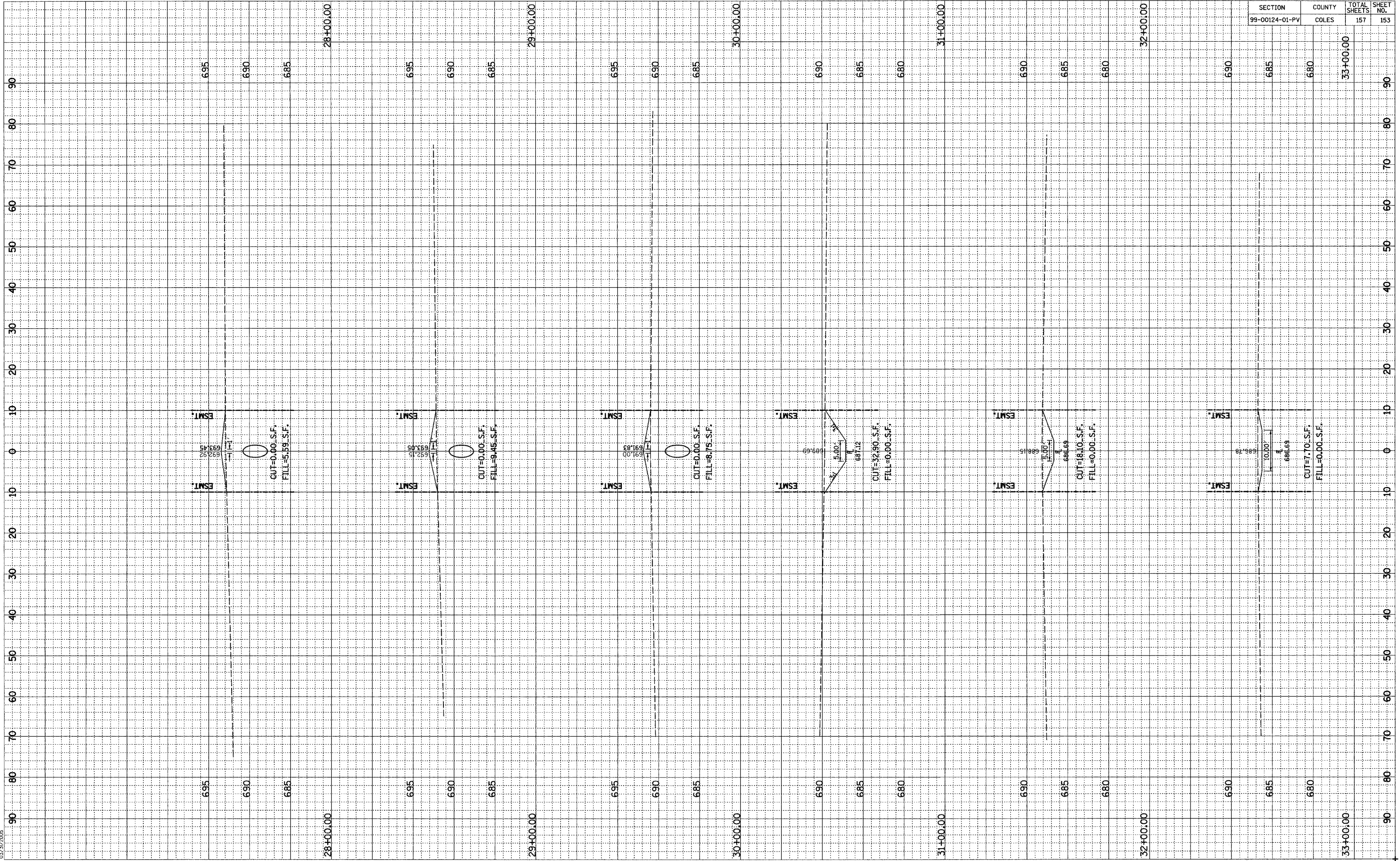

DRAWN BY S.J.F.
 CHK'D BY J.M.E.
 TUC PROJ. #191022-5
 33 SHEETS WEST 567
 02/27/2006

T.12N.-R.7E., 3rd P.M., MATTOON TWP.

T.13N.-R.7E., 3rd P.M., NORTH OKAW TWP.

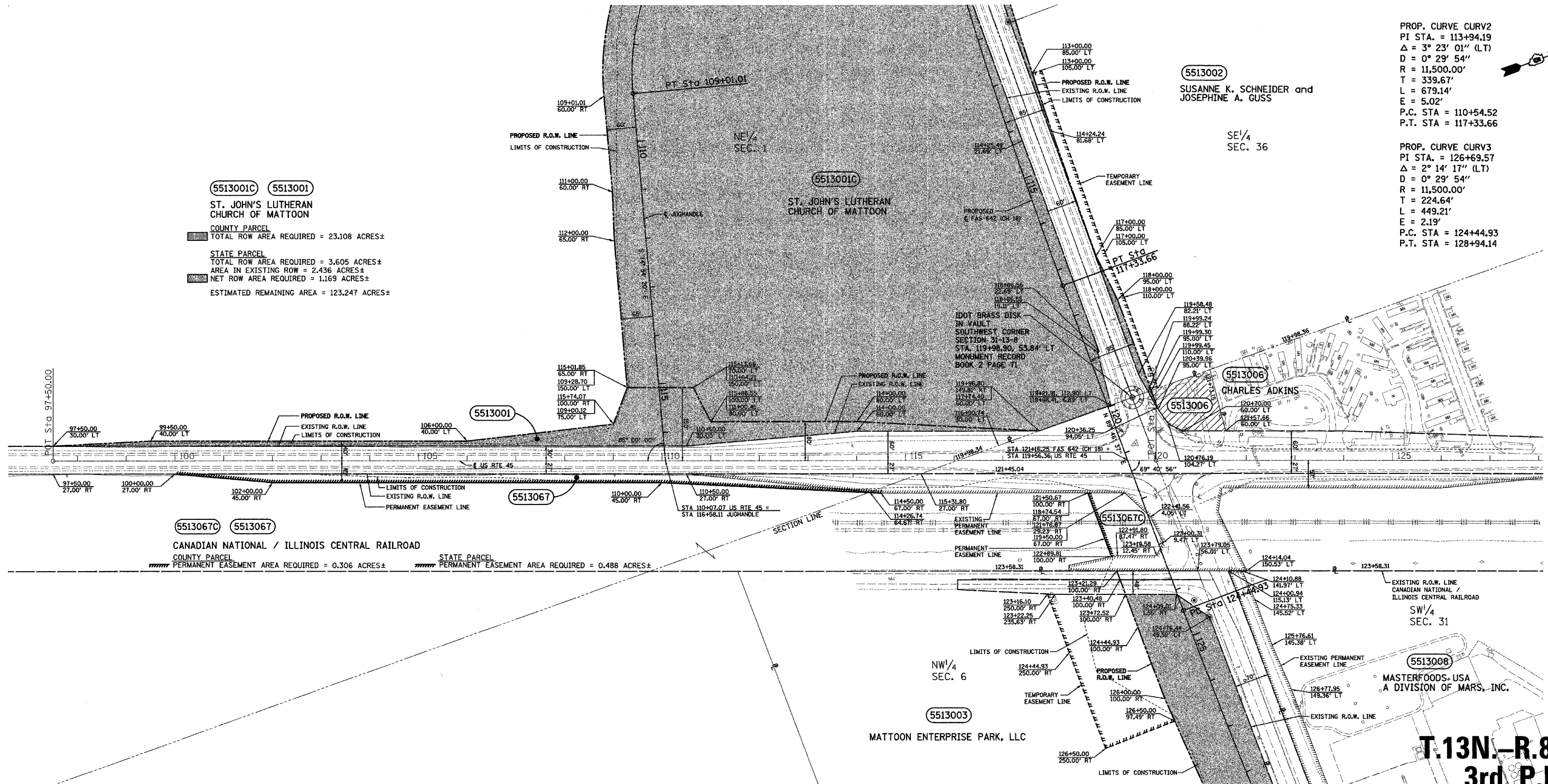

5513001C 5513001
ST. JOHN'S LUTHERAN CHURCH OF MATTOON
 COUNTY PARCEL
 TOTAL ROW AREA REQUIRED = 23.108 ACRES±
 STATE PARCEL
 TOTAL ROW AREA REQUIRED = 3.605 ACRES±
 AREA IN EXISTING ROW = 2.436 ACRES±
 NET ROW AREA REQUIRED = 1.169 ACRES±
 ESTIMATED REMAINING AREA = 123.247 ACRES±

5513067C 5513067
CANADIAN NATIONAL / ILLINOIS CENTRAL RAILROAD
 COUNTY PARCEL
 PERMANENT EASEMENT AREA REQUIRED = 0.306 ACRES±
 STATE PARCEL
 PERMANENT EASEMENT AREA REQUIRED = 0.488 ACRES±

5513002
 SUSANNE K. SCHNEIDER and
 JOSEPHINE A. GUSS

PROP. CURVE CURV2
 PI STA. = 113+94.19
 $\Delta = 3^\circ 23' 01''$ (LT)
 $D = 0^\circ 29' 54''$
 $R = 11,500.00'$
 $T = 339.67'$
 $L = 679.14'$
 $E = 5.02'$
 P.C. STA = 110+54.52
 P.T. STA = 117+33.66

PROP. CURVE CURV3
 PI STA. = 126+69.57
 $\Delta = 2^\circ 14' 17''$ (LT)
 $D = 0^\circ 29' 54''$
 $R = 11,500.00'$
 $T = 224.64'$
 $L = 449.21'$
 $E = 2.19'$
 P.C. STA = 124+44.93
 P.T. STA = 128+94.14



T.12N.-R.8E., 3rd P.M., LAFAYETTE TWP.

T.13N.-R.8E., 3rd P.M., HUMBOLDT TWP.

LEGEND
 ● - IRON PIN
 ⊙ - BRASS DISK

NOTES:
 1. PERMANENT EASEMENTS ARE REQUIRED FOR HIGHWAY CONSTRUCTION AND EARTHWORK.
 2. TEMPORARY EASEMENTS ARE REQUIRED FOR ENTRANCE CONSTRUCTION AND EARTHWORK.
 3. ALL BEARINGS ARE REFERENCED TO THE ILLINOIS STATE PLANE COORDINATE SYSTEM EAST ZONE DATUM OF 1983.

STATION	OFFSET	LABEL
119+98.90	-53.84	BRASS DISK
124+33.12	-28.02	PIN
124+76.84	-45.64	PIN

REVISION		COUNTY OF COLES RIGHT OF WAY PLAN
DATE	DESCRIPTION	
10-23-03	REV. TITLE BLOCK	ROUTE F.A.S. 642 (CH 18) SECTION 99-00124-00-PV COUNTY COLES JOB# R-95-051-03 SEC 1-12-7, 6-12-8, 31-13-8 & 36-13-7 STA 97+50 TO STA 128+00 (RT 45) DRAWN S.A.E. CHECKED D.E.H. SCALE: 1" = 100' SHEET NO. 2 OF 23
10-23-03	ADD TEMP. ESMT.	
11-04-04	REMANANT OOS	
3-11-05	OWNER OOS	

T.13N.-R.7E., 3rd P.M., NORTH OKAW TWP.

T.13N.-R.8E., 3rd P.M., HUMBOLDT TWP.

PROP. CURVE CURV1
 PI STA. = 103+43.25
 $\Delta = 2^\circ 46' 12''$ (RT)
 $D = 0^\circ 29' 54''$
 $R = 11,500.00'$
 $T = 278.05'$
 $L = 555.99'$
 $E = 3.36'$
 P.C. STA = 100+65.20
 P.T. STA = 106+21.19

5513078
 GREGORY R. SCHAEFER and
 PEGGY R. SCHAEFER
 TOTAL ROW AREA REQUIRED = 0.198 ACRES±
 TEMPORARY EASEMENT AREA REQUIRED = 0.035 ACRES±

SE/4
SEC. 36

5513004
 FRED HARTBANK and
 KAREN HARTBANK
 TOTAL ROW AREA REQUIRED = 0.122 ACRES±
 TEMPORARY EASEMENT AREA REQUIRED = 0.246 ACRES±

5513002
 SUSANNE K. SCHNEIDER and
 JOSEPHINE A. GUSS
 TOTAL ROW AREA REQUIRED = 0.298 ACRES±
 TEMPORARY EASEMENT AREA REQUIRED = 0.291 ACRES±

PROP. CURVE CURV2
 PI STA. = 113+94.19
 $\Delta = 3^\circ 23' 01''$ (LT)
 $D = 0^\circ 29' 54''$
 $R = 11,500.00'$
 $T = 339.67'$
 $L = 679.14'$
 $E = 5.02'$
 P.C. STA = 110+54.52
 P.T. STA = 117+33.66

5513006
 CHARLES ADKINS
 TOTAL AREA TO BE ACQUIRED = 0.299 ACRES±
 NET ROW AREA REQUIRED = 0.003 ACRES±
 REMNANT TO BE ACQUIRED = 0.296 ACRES±

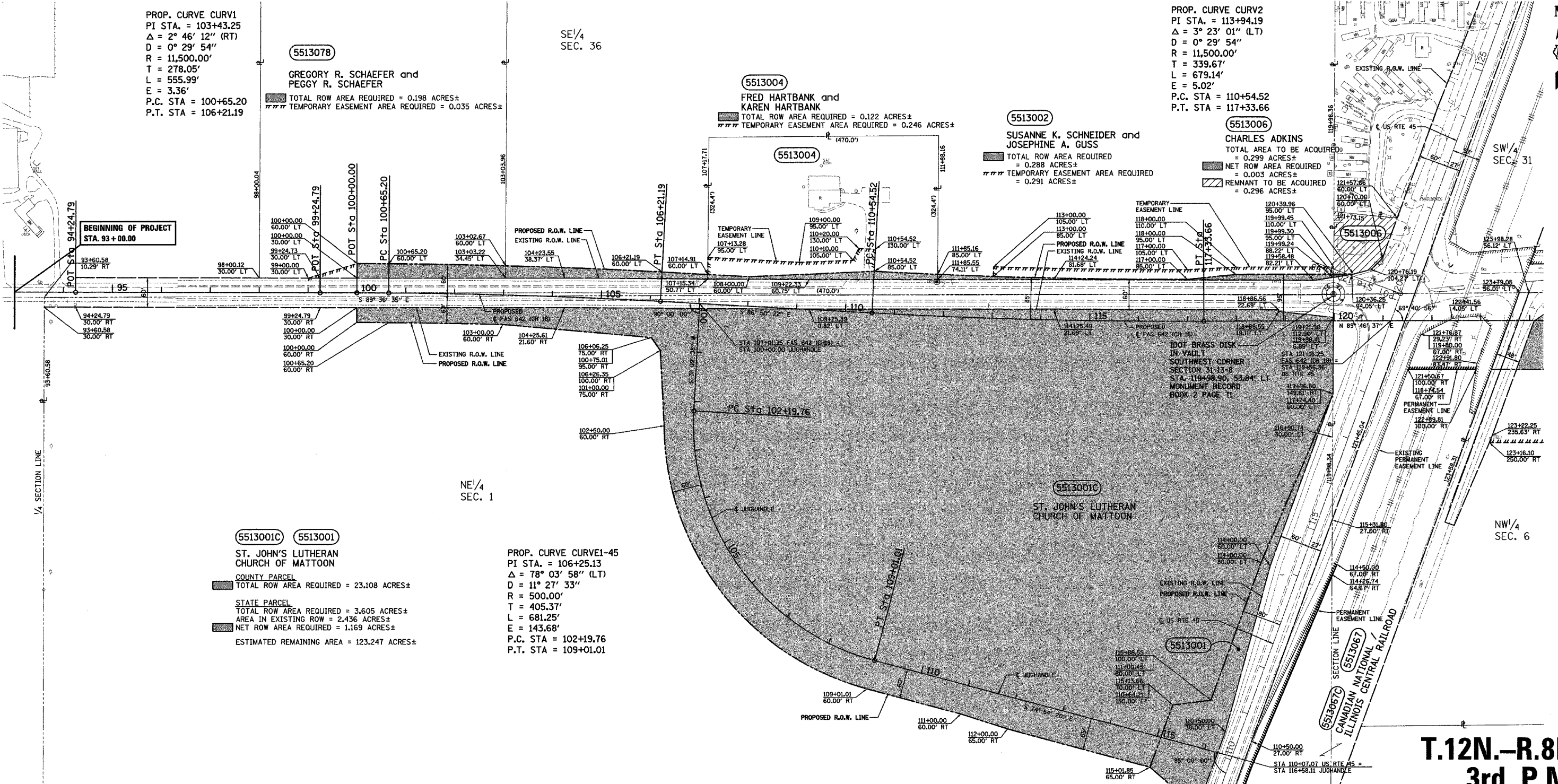
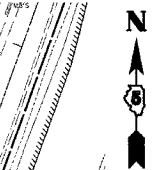

5513001C **5513001**
 ST. JOHN'S LUTHERAN
 CHURCH OF MATTOON
 COUNTY PARCEL
 TOTAL ROW AREA REQUIRED = 23.108 ACRES±
 STATE PARCEL
 TOTAL ROW AREA REQUIRED = 3.605 ACRES±
 AREA IN EXISTING ROW = 2.436 ACRES±
 NET ROW AREA REQUIRED = 1.169 ACRES±
 ESTIMATED REMAINING AREA = 123.247 ACRES±

PROP. CURVE CURVE1-45
 PI STA. = 106+25.13
 $\Delta = 78^\circ 03' 58''$ (LT)
 $D = 11^\circ 27' 33''$
 $R = 500.00'$
 $T = 405.37'$
 $L = 681.25'$
 $E = 143.68'$
 P.C. STA = 102+19.76
 P.T. STA = 109+01.01

T.12N.-R.7E., 3rd P.M., MATTOON TWP.

T.12N.-R.8E., 3rd P.M., LAFAYETTE TWP.

LEGEND
 (O) - IRON PIN
 (D) - BRASS DISK
 (R) - RECORDED DISTANCE

NOTES:
 1. TEMPORARY EASEMENTS ARE REQUIRED FOR ENTRANCE CONSTRUCTION AND EARTHWORK.
 2. ALL BEARINGS ARE REFERENCED TO THE ILLINOIS STATE PLANE COORDINATE SYSTEM EAST ZONE DATUM OF 1983.

STATION	OFFSET	LABEL
111+84.44	-69.33	PIN
119+98.90	-53.84	BRASS DISK

REVISION		COUNTY OF COLES RIGHT OF WAY PLAN
DATE	DESCRIPTION	
10-23-03	REV. TITLE BLOCK	ROUTE F.A.S. 642 (CH 18) SECTION 99-00124-00-PV COUNTY COLES JOB# R-95-051-03 SEC 1-12-7, 6-12-8, 31-13-8 & 36-13-7 STA 93+00 TO STA 124+00 DRAWN S.A.E. CHECKED D.E.H. SCALE: 1"= 100' SHEET NO. 3 OF 23
10-23-03	ADD TEMP. ESMT.	
11-04-04	REMNANT 006	

T.13N.-R.8E., 3rd P.M., HUMBOLDT TWP.

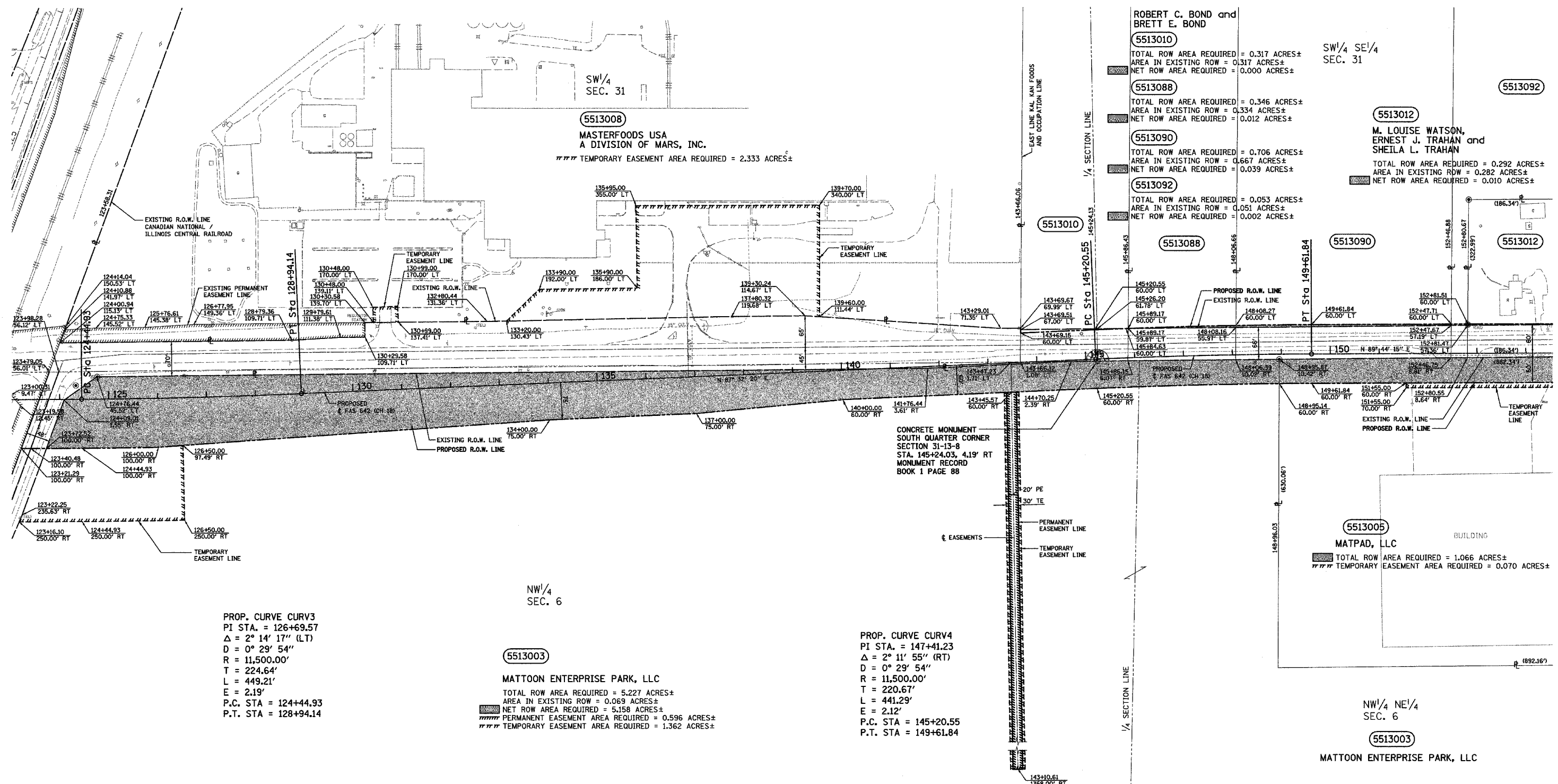

ROBERT C. BOND and
BRETT E. BOND
5513010
TOTAL ROW AREA REQUIRED = 0.317 ACRES±
AREA IN EXISTING ROW = 0.317 ACRES±
NET ROW AREA REQUIRED = 0.000 ACRES±

5513088
TOTAL ROW AREA REQUIRED = 0.346 ACRES±
AREA IN EXISTING ROW = 0.334 ACRES±
NET ROW AREA REQUIRED = 0.012 ACRES±

5513090
TOTAL ROW AREA REQUIRED = 0.706 ACRES±
AREA IN EXISTING ROW = 0.667 ACRES±
NET ROW AREA REQUIRED = 0.039 ACRES±

5513092
TOTAL ROW AREA REQUIRED = 0.053 ACRES±
AREA IN EXISTING ROW = 0.051 ACRES±
NET ROW AREA REQUIRED = 0.002 ACRES±

SW¼ SE¼
SEC. 31

5513092
M. LOUISE WATSON,
ERNEST J. TRAHAN and
SHEILA L. TRAHAN
TOTAL ROW AREA REQUIRED = 0.292 ACRES±
AREA IN EXISTING ROW = 0.282 ACRES±
NET ROW AREA REQUIRED = 0.010 ACRES±

5513088

5513090

5513012

SW¼
SEC. 31
5513008
MASTERFOODS USA
A DIVISION OF MARS, INC.
TEMPORARY EASEMENT AREA REQUIRED = 2.333 ACRES±

CONCRETE MONUMENT
SOUTH QUARTER CORNER
SECTION 31-13-8
STA. 145+24.03, 4.19' RT
MONUMENT RECORD
BOOK 1 PAGE 88

5513005
MATPAD, LLC
TOTAL ROW AREA REQUIRED = 1.066 ACRES±
TEMPORARY EASEMENT AREA REQUIRED = 0.070 ACRES±

NW¼
SEC. 6

PROP. CURVE CURV3
PI STA. = 126+69.57
Δ = 2° 14' 17" (LT)
D = 0° 29' 54"
R = 11,500.00'
T = 224.64'
L = 449.21'
E = 2.19'
P.C. STA = 124+44.93
P.T. STA = 128+94.14

5513003
MATTOON ENTERPRISE PARK, LLC
TOTAL ROW AREA REQUIRED = 5.227 ACRES±
AREA IN EXISTING ROW = 0.069 ACRES±
NET ROW AREA REQUIRED = 5.158 ACRES±
PERMANENT EASEMENT AREA REQUIRED = 0.596 ACRES±
TEMPORARY EASEMENT AREA REQUIRED = 1.362 ACRES±

PROP. CURVE CURV4
PI STA. = 147+41.23
Δ = 2° 11' 55" (RT)
D = 0° 29' 54"
R = 11,500.00'
T = 220.67'
L = 441.29'
E = 2.12'
P.C. STA = 145+20.55
P.T. STA = 149+61.84

NW¼ NE¼
SEC. 6

5513003
MATTOON ENTERPRISE PARK, LLC

- LEGEND
- ⊙ - IRON PIN
 - ⊖ - IRON PIPE
 - ⊙ - CONCRETE MONUMENT
 - (R) - RECORDED DISTANCE

- NOTES:
1. PERMANENT EASEMENT IS REQUIRED FOR DRAINAGE.
 2. TEMPORARY EASEMENTS ARE REQUIRED FOR STORM SEWER AND ENTRANCE CONSTRUCTION AND EARTHWORK.
 3. ALL BEARINGS ARE REFERENCED TO THE ILLINOIS STATE PLANE COORDINATE SYSTEM EAST ZONE DATUM OF 1983.

STATION	OFFSET	LABEL
124+33.12	-28.02	PIN
124+76.84	-45.64	PIN
145+24.03	4.19	CONC. MON.
148+95.87	10.49	PIN
152+81.49	-58.75	PIPE

T.12N.-R.8E., 3rd P.M., LAFAYETTE TWP.

REVISION		COUNTY OF COLES RIGHT OF WAY PLAN
DATE	DESCRIPTION	
10-23-03	REV. TITLE BLOCK	ROUTE F.A.S. 642 (CH 18) SECTION 99-00124-00-PV COUNTY COLES JOB# R-95-051-03 SEC 6-12-8 & 31-13-8 STA 124+00 TO STA 154+00 DRAWN S.A.E. CHECKED D.E.H. SCALE: 1"= 100' SHEET NO. 4 OF 23
12-29-03	PE PAR. 5513003	
4-13-04	OWNER 5513012	
4-27-04	DIVIDE 5513010	
10-21-04	TE PAR. 5513008	
3-11-05	OWNER 5513008	

T.13N.-R.8E., 3rd P.M., HUMBOLDT TWP.

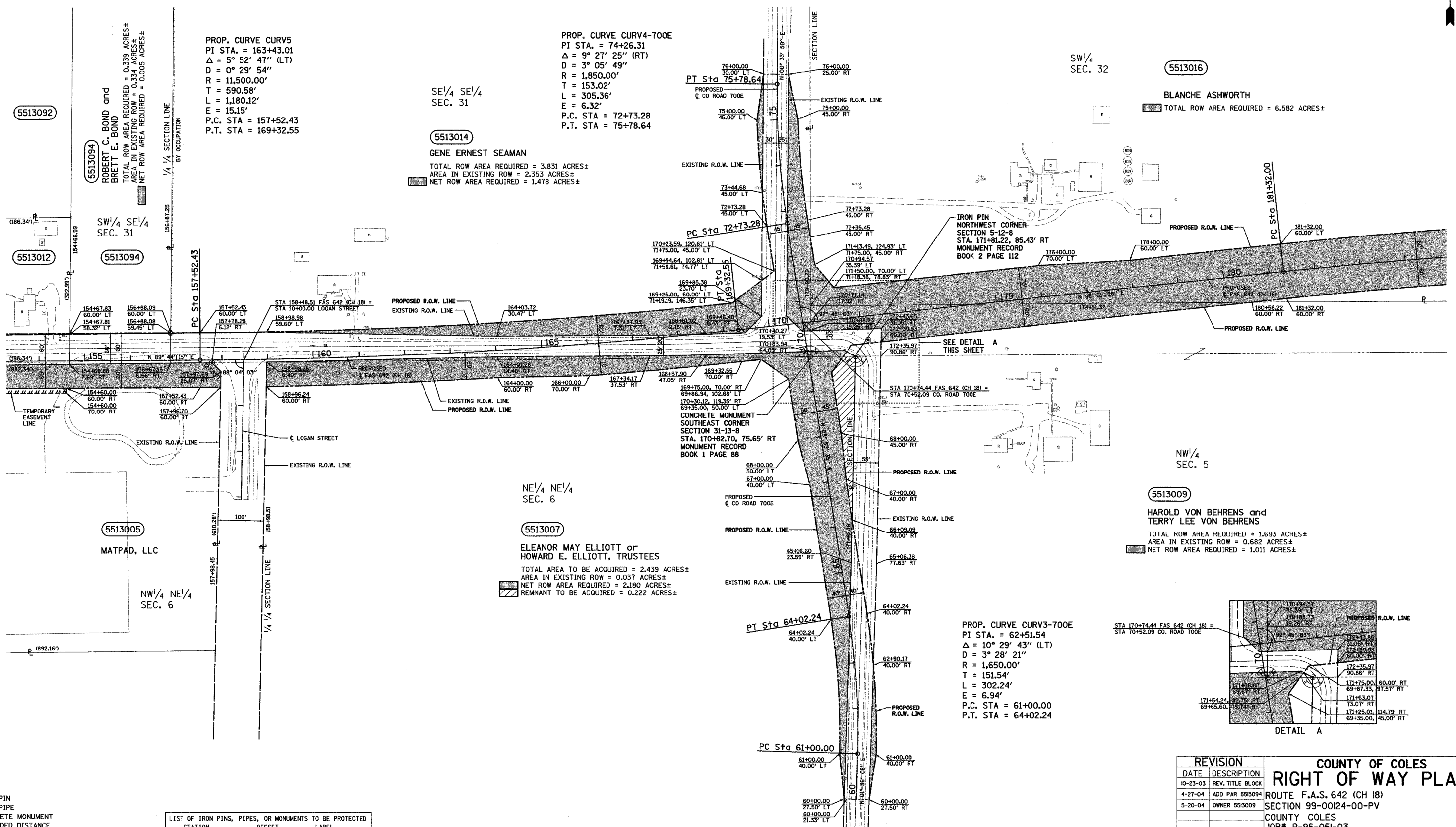

PROP. CURVE CURV5
 PI STA. = 163+43.01
 $\Delta = 5^\circ 52' 47''$ (LT)
 $D = 0^\circ 29' 54''$
 $R = 11,500.00'$
 $T = 590.58'$
 $L = 1,180.12'$
 $E = 15.15'$
 P.C. STA = 157+52.43
 P.T. STA = 169+32.55

PROP. CURVE CURV4-700E
 PI STA. = 74+26.31
 $\Delta = 9^\circ 27' 25''$ (RT)
 $D = 3^\circ 05' 49''$
 $R = 1,850.00'$
 $T = 153.02'$
 $L = 305.36'$
 $E = 6.32'$
 P.C. STA = 72+73.28
 P.T. STA = 75+78.64

SE 1/4 SE 1/4
 SEC. 31
 5513014
 GENE ERNEST SEAMAN
 TOTAL ROW AREA REQUIRED = 3.831 ACRES±
 AREA IN EXISTING ROW = 2.353 ACRES±
 NET ROW AREA REQUIRED = 1.478 ACRES±

SW 1/4
 SEC. 32
 5513016
 BLANCHE ASHWORTH
 TOTAL ROW AREA REQUIRED = 6.582 ACRES±

NE 1/4 NE 1/4
 SEC. 6
 5513007
 ELEANOR MAY ELLIOTT or
 HOWARD E. ELLIOTT, TRUSTEES
 TOTAL AREA TO BE ACQUIRED = 2.439 ACRES±
 AREA IN EXISTING ROW = 0.037 ACRES±
 NET ROW AREA REQUIRED = 2.180 ACRES±
 REMNANT TO BE ACQUIRED = 0.222 ACRES±

NW 1/4
 SEC. 5
 5513009
 HAROLD VON BEHRENS and
 TERRY LEE VON BEHRENS
 TOTAL ROW AREA REQUIRED = 1.693 ACRES±
 AREA IN EXISTING ROW = 0.682 ACRES±
 NET ROW AREA REQUIRED = 1.011 ACRES±

PROP. CURVE CURV3-700E
 PI STA. = 62+51.54
 $\Delta = 10^\circ 29' 43''$ (LT)
 $D = 3^\circ 28' 21''$
 $R = 1,650.00'$
 $T = 151.54'$
 $L = 302.24'$
 $E = 6.94'$
 P.C. STA = 61+00.00
 P.T. STA = 64+02.24

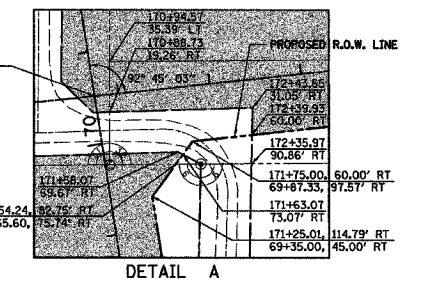

- LEGEND**
- ⊙ - IRON PIN
 - ⊖ - IRON PIPE
 - ⊙ - CONCRETE MONUMENT
 - (R) - RECORDED DISTANCE

LIST OF IRON PINS, PIPES, OR MONUMENTS TO BE PROTECTED

STATION	OFFSET	LABEL
156+88.09	-59.77	PIPE
157+78.28	6.18	PIN
170+82.70	75.65	CONC. MON.
171+81.22	85.43	PIN
172+12.49	52.52	PIN

- NOTES**
- TEMPORARY EASEMENTS ARE REQUIRED FOR ENTRANCE CONSTRUCTION AND EARTHWORK.
 - ALL BEARINGS ARE REFERENCED TO THE ILLINOIS STATE PLANE COORDINATE SYSTEM EAST ZONE DATUM OF 1983.

REVISION		DATE	DESCRIPTION

**COUNTY OF COLES
 RIGHT OF WAY PLAN**

ROUTE F.A.S. 642 (CH 18)
 SECTION 99-00124-00-PV
 COUNTY COLES
 JOB# R-95-051-03
 SEC 5-12-8, 6-12-8, 31-13-8 & 32-13-8
 STA 154+00 TO STA 184+00
 DRAWN S.A.E. CHECKED D.E.H.
 SCALE: 1" = 100' SHEET NO. 5 OF 23

T.12N.-R.8E., 3rd P.M., LAFAYETTE TWP.