

F.A.P. RTE.	SECTION	COUNTY	TOTAL SHEETS	SHEET NO.
311	652X-N-3	DUPAGE	34	1
FED. ROAD DIST. NO. 1	ILLINOIS	CONTRACT NO.	60L22	

D-91-658-10

STATE OF ILLINOIS
DEPARTMENT OF TRANSPORTATION
DIVISION OF HIGHWAYS
**PROPOSED
HIGHWAY PLANS**

F.A.P. 311: US ROUTE 34
AT NORTH AURORA ROAD/RAYMOND DRIVE
SECTION: 652X-N-3
LOCATION OF PROJECT
PROJECT: *HSIP-0311(045)*
DU PAGE COUNTY
C-91-658-10

FOR INDEX OF SHEETS, SEE SHEET NO. 2

DESIGN DESIGNATION
US ROUTE 34 (OGDEN AVE)
FUNCTION CLASSIFICATION: MAJOR ARTERIAL
DESIGN SPEED=45 MPH
POSTED SPEED=40 MPH
NORTH AURORA ROAD
FUNCTIONAL CLASSIFICATION=MINOR ARTERIAL
DESIGN SPEED=45 MPH
POSTED SPEED=40 MPH
RAYMOND DR
FUNCTIONAL CLASSIFICATION=MAJOR ARTERIAL
DESIGN SPEED=45 MPH
POSTED SPEED=40 MPH

TRAFFIC DATA
US 34 (OGDEN AVE)
2009 ADT=37,000
N. AURORA RD
2009 ADT=17,300
RAYMOND DR
2009 ADT=26,200

PROJECT LOCATED WITHIN
THE CITY OF NAPERVILLE

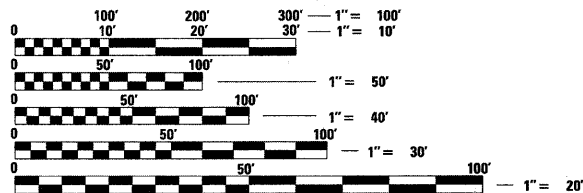

FULL SIZE PLANS HAVE BEEN PREPARED USING STANDARD ENGINEERING SCALES. REDUCED SIZED PLANS WILL NOT CONFORM TO STANDARD SCALES. IN MAKING MEASUREMENTS ON REDUCED PLANS, THE ABOVE SCALES MAY BE USED.

J.U.L.I.E.
JOINT UTILITY LOCATION INFORMATION FOR EXCAVATION
1-800-892-0123 OR 811

LOCATION OF PROJECT

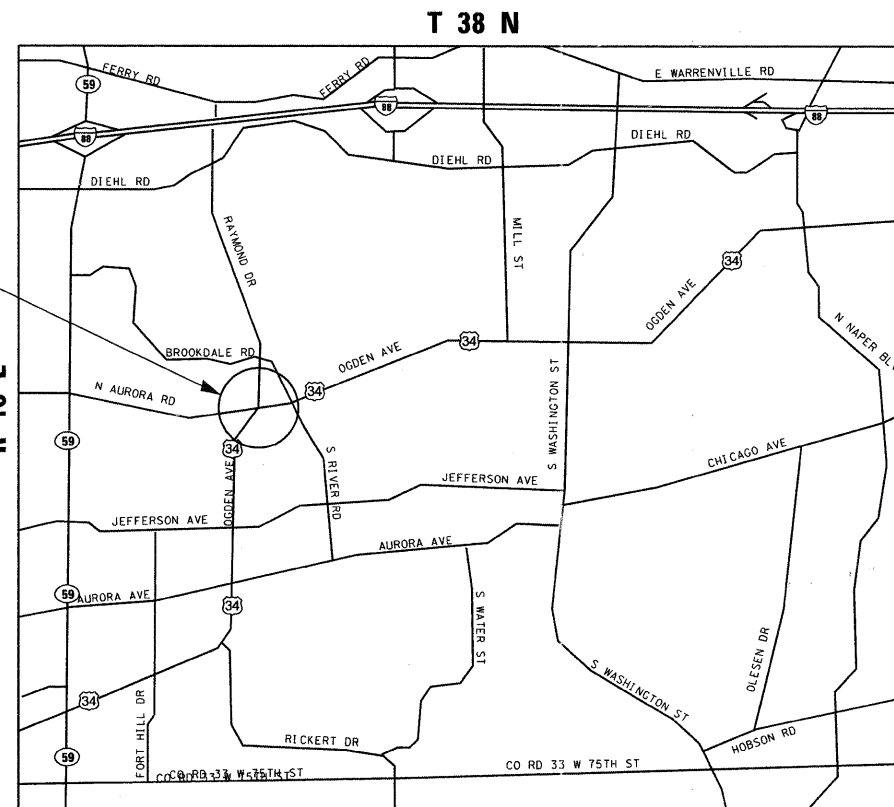

SCALE: NTS
NAPERVILLE TOWNSHIP

GROSS & NET LENGTH OF PROJECT= 1650 FT = 0.31 MILES



LOCATION OF SECTION INDICATED THIS: - [Symbol] -

DISTRICT ONE - PLAN PREP ENGINEER: KEN ENG (847) 705-4247



MILLENNIA PROFESSIONAL SERVICES
THOMAS V. NGO, P.E.
062-058379

Thomas V. Ngo
DATE: 05/27/2011
SIGNATURE AND SEAL APPLIES TO DRWG NO 1-18 AND 21



LIN ENGINEERING, LTD.
MICHAEL T. HALEY, S.E.
81-5991

Michael T. Haley
DATE: 05/27/2011
SIGNATURE AND SEAL APPLIES TO DRWG NO 19 TO 20

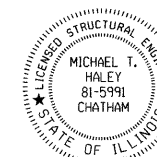

GANDHI AND ASSOCIATES INC.
P.K. GANDHI, P.E.
062-034993

P.K. Gandhi
DATE: 05/27/2011
SIGNATURE AND SEAL APPLIES TO DRWG NO 22 TO 22

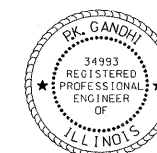

STATE OF ILLINOIS
DEPARTMENT OF TRANSPORTATION
DIVISION OF HIGHWAYS

SUBMITTED *May 31* 20 *11*

Piase O'Keefe
DEPUTY DIRECTOR OF HIGHWAYS, REGION ENGINEER

July 1 20 *11*
Scott E. Stitt P.E.
ENGINEER OF DESIGN AND ENVIRONMENT

July 1 20 *11*
Christine M. Reed
DIRECTOR OF HIGHWAYS, CHIEF ENGINEER

 200 22ND Street, Suite 216, Lombard, IL 60148
630.705.0110 voice, 630.839.2566 fax
www.mps-il.com

MILLENNIA PROFESSIONAL SERVICES

PRINTED BY THE AUTHORITY
OF THE STATE OF ILLINOIS

CONTRACT NO. 60L22

INDEX OF SHEETS

- 1 COVER SHEET
- 2 INDEX OF SHEETS, HIGHWAY STANDARDS, GENERAL NOTES, AND COMMITMENTS
- 3-4 SUMMARY OF QUANTITIES
- 5 TYPICAL SECTIONS
- 6-7 ALIGNMENT AND TIES
- 8-9 REMOVAL PLAN
- 10-11 ROADWAY PLAN
- 12 SUGGESTED STAGES OF CONSTRUCTION AND TRAFFIC CONTROL GENERAL NOTES AND DESCRIPTION
- 13-14 SUGGESTED STAGES OF CONSTRUCTION AND TRAFFIC CONTROL PLANS
- 15-16 DRAINAGE & UTILITY PLANS
- 17-18 PAVEMENT MARKING AND LANDSCAPE PLAN
- 19-20 RETAINING WALL, GENERAL PLAN AND ELEVATION (LIN ENGR)
- 21 TRAFFIC SIGNAL PLAN
- 22 PROPOSED LIGHTING PLAN (GANDHI AND ASSOCIATE)
- 23 LIGHT POLE FOUNDATION (BE-301)
- 24 FRAMES AND LIDS ADJUSTMENT WITH MILLING; AND FRAMES AND LIDS ADJUSTMENT WITHOUT MILLING (BD08)
- 25 PAVEMENT PATCHING FOR HMA SURFACED PAVEMENT (BD22)
- 26 BUTT JOINTS AND HMA TAPER (BD32)
- 27 TRAFFIC CONTROL AND PROTECTION FOR SIDE ROADS, INTERSECTIONS AND DRIVEWAYS (TC10)
- 28 RAISED REFLECTIVE PAVEMENT MARKERS, SNOW PLOW RESISTANT (TC11)
- 29 DISTRICT ONE TYPICAL PAVEMENT MARKINGS (TC13)
- 30 TRAFFIC CONTROL AND PROTECTION FOR AT TURN BAYS (TC14)
- 31 PAVEMENT MARKING LETTERS AND SYMBOLS FOR TRAFFIC STAGING (TC-16)
- 32 ARTERIAL ROAD INFORMATION SIGN (TC22)
- 33 DETECTOR LOOP INSTALLATION DETAILS FOR ROADWAY (TS07)
- 34 CROSS SECTIONS - US ROUTE 34 (OGDEN AVENUE)

LIST OF ILLINOIS DOT HIGHWAY STANDARDS

- 000001-00 STANDARD SYMBOLS, ABBREVIATIONS, AND PATTERNS
- 001006 DECIMAL OF AN INCH AND OF A FOOT
- 424001-05 CURB RAMP FOR SIDEWALKS
- 442201-03 CLASS C AND D PATCHES
- 482011-03 HMA SHOULDER STRIPS/SHOULDERS WITH RESURFACING OR WIDENING AND RESURFACING PROJECTS
- 602001-02 CATCH BASIN TYPE A
- 602011-02 CATCH BASIN TYPE C
- 602016-02 CATCH BASIN TYPE D
- 602301-03 INLET - TYPE A
- 602401-03 MANHOLE TYPE A
- 604001-03 FRAMES AND LIDS, TYPE 1
- 604041-02 FRAME AND GRATE TYPE 9
- 604091-02 FRAME AND GRATE TYPE 24
- 606001-04 CONCRETE CURB TYPE B AND COMBINATION CONCRETE CURB AND GUTTER
- 701201-04 LANE CLOSURE, 2L, 2W, DAY ONLY, FOR SPEEDS >= 45 MPH
- 701301-04 LANE CLOSURE, 2L, 2W, SHORT TIME OPERATIONS
- 701306-03 LANE CLOSURE, 2L, 2W, SLOW MOVING OPERATIONS DAY ONLY, FOR SPEEDS >= 45 MPH
- 701311-03 LANE CLOSURE, 2L, 2W, MOVING OPERATIONS - DAY ONLY
- 701336-06 LANE CLOSURE, 2L, 2W, WORK AREAS IN SERIES, FOR SPEEDS > 45 MPH
- 701431-06 LANE CLOSURE, MULTILANE, UNDIV. WITH CROSSOVER, FOR SPEEDS > 45 MPH TO 55 MPH
- 701501-06 URBAN LANE CLOSURE, 2L, 2W, UNDIVIDED
- 701606-07 URBAN LANE CLOSURE, MULTILANE, 2W WITH MOUNTABLE MEDIAN
- 701701-07 URBAN LANE CLOSURE, MULTILANE INTERSECTION
- 701901-01 TRAFFIC CONTROL DEVICES
- 814001-02 HANDHOLES

COMMITMENTS

NO COMMITMENTS FOR THIS PROJECT

GENERAL NOTES

- 1. BEFORE STARTING ANY EXCAVATION, THE CONTRACTOR SHALL CALL "J.U.L.I.E." AT 800-892-0123 FOR FIELD LOCATIONS OF BURIED ELECTRIC, TELEPHONE, AND GAS FACILITIES. 48 HOUR NOTIFICATION IS REQUIRED.
- 2. THE CONTRACTOR SHALL COORDINATE CONSTRUCTION ACTIVITIES WITH THE UTILITY COMPANIES, CITY OF NAPERVILLE.
- 3. THE CONTRACTOR WILL NOT BE ALLOWED TO SET UP A YARD OR FIELD OFFICE ON STATE PROPERTY WITHOUT WRITTEN PERMISSION FROM THE DEPARTMENT.
- 4. ANY PAVEMENT MARKINGS AND RAISED REFLECTIVE PAVEMENT MARKERS OBLITERATED BY MILLING AND RESURFACING OPERATIONS ON SIDE STREETS AND ENTRANCES SHALL BE REPLACED AND PAID FOR IN KIND.
- 5. ALL DAMAGE TO EXISTING PAVEMENT MARKING OR RAISED REFLECTIVE PAVEMENT MARKERS OUTSIDE THE REMOVAL LINE SHOWN ON THE PLANS SHALL BE REPLACED AT THE CONTRACTORS EXPENSE. NO ADDITIONAL COST TO THE DEPARTMENT.
- 6. BEFORE BEGINNING ANY WORK, THE CONTRACTOR SHALL RETAIN AND RECORD FOR FUTURE REFERENCES, ALL EXISTING PAVEMENT MARKING LINES AND RAISED REFLECTIVE PAVEMENT MARKERS IN ORDER THAT THESE LOCATIONS CAN BE RE-ESTABLISHED FOR STRIPING. EXACT LOCATIONS OF ALL STRIPING SHALL BE AS DIRECTED BY THE ENGINEER.
- 7. ALL PAVEMENT PATCHING LOCATIONS WILL BE DETERMINED IN THE FIELD BY THE ENGINEER.
- 8. THE CONTRACTOR SHALL BE RESPONSIBLE FOR VERIFYING ALL DIMENSIONS AND CONDITIONS EXISTING IN THE FIELD PRIOR TO CONSTRUCTION AND ORDERING MATERIALS.
- 9. THE CONTRACTOR SHALL CONTACT THE DISTRICT ONE TRAFFIC CONTROL SUPERVISOR AT (847) 705-4470 A MINIMUM OF 72 HOURS IN ADVANCE OF BEGINNING WORK.
- 10. THE ENGINEER SHALL CONTACT DON CHIARUGI, THE TRAFFIC FIELD ENGINEER AT (847) 741-9857 A MINIMUM OF TWO (2) WEEKS PRIOR TO THE PLACEMENT OF PERMANENT PAVEMENT MARKINGS.
- 11. THE CONTRACTOR SHALL BE REQUIRED TO PROVIDE ACCESS TO ABUTTING PROPERTY AT ALL TIMES DURING THE CONSTRUCTION OF THIS PROJECT.
- 12. DO NOT SCALE PLANS FOR CONSTRUCTION DIMENSIONS.
- 13. DOUBLE LANE MARKERS ARE TO BE USED AS SHOWN ON THE DISTRICT ONE DETAIL "TYPICAL APPLICATIONS - RAISED REFLECTIVE PAVEMENT MARKERS (SNOW-PLOW RESISTANT)" SHOWN ON THE PLANS.
- 14. WHEN MILLED PAVEMENT IS OPEN TO TRAFFIC THE MAXIMUM GRADE DIFFERENTIAL BETWEEN PASSES OF THE MILLING MACHINE SHALL NOT EXCEED 1 1/2 INCHES WHERE THE SPEED LIMIT IS 45 MPH OR LESS AND 1 INCH WHERE THE SPEED LIMIT IS GREATER THAN 45 MPH. WITH WRITTEN APPROVAL FROM THE ENGINEER, A MAXIMUM GRADE DIFFERENTIAL OF 3 INCHES MAY BE ALLOWED IF THE EDGE OF THE MILLING IS SLOPED A MINIMUM 1:3 (V:H).
- 15. BUTT JOINTS WILL BE INSTALLED AT THE ENDS OF ALL RESURFACING (WHERE RESURFACING MEETS EXISTING PAVEMENT), IN ACCORDANCE WITH THE "BUTT JOINT AND HOT-MIX ASPHALT TAPER DETAILS" SHEET INCLUDED IN THE PLANS UNLESS OTHERWISE SPECIFIED.
- 16. PAVEMENT MARKING TAPE, TYPE III SHALL BE USED FOR SHORT TERM PAVEMENT MARKINGS ON ALL FINAL SURFACES. THE COST OF THE PAVEMENT MARKING TAPE, TYPE III AND IT'S REMOVAL SHALL BE INCLUDED IN THE COST OF SHORT TERM PAVEMENT MARKING.
- 17. THE CONTRACTOR SHALL PLACE PROPOSED PAVEMENT MARKINGS IN ACCORDANCE WITH DISTRICT 1 TYPICAL PAVEMENT MARKINGS DETAIL (TC-13).
- 18. THE RESIDENT ENGINEER AND CONTRACTOR SHALL VERIFY ALL EXISTING PAVEMENT MARKING PRIOR TO THE PROJECT STARTING. IF A DISCREPANCIES OCCURS BETWEEN EXISTING PAVEMENT MARKINGS AND THE PROPOSED PAVEMENT MARKINGS, THE RESIDENT ENGINEER SHALL CONTACT THE BUREAU OF TRAFFIC OPERATIONS.

P:\2009\ME09006.Var-Ver-Phil\CADD\W022.US34.Shts\02-GNOTE.sht-US34.dgn
 FILE NAME : P:\2009\ME09006.Var-Ver-Phil\CADD\W022.US34.Shts\02-GNOTE.sht-US34.dgn
 PLOT SCALE : 1/8"=1'-0"
 USER NAME : Millennium Professional Services



200 22ND Street, Suite 216, Lombard, IL 60148
 630.705.0110 voice, 630.839.2566 fax
 www.mps-ill.com

MILLENNIA PROFESSIONAL SERVICES

DESIGNED - CJD	REVISED -
DRAWN - CJD	REVISED -
CHECKED - TVN	REVISED -
DATE - 5/31/2011	REVISED -

**STATE OF ILLINOIS
 DEPARTMENT OF TRANSPORTATION**

**US ROUTE 34
 AT NORTH AURORA ROAD /RAYMOND DRIVE**

**INDEX OF SHEETS, LIST OF IDOT
 HIGHWAY STANDARD, GENERAL NOTES,
 AND COMMITMENTS**

F.A.P. RTE. 311	SECTION 652X-N-3	COUNTY DUPAGE	TOTAL SHEETS 34	SHEET NO. 2
CONTRACT NO. 60L22				
FED. ROAD DIST. NO. 1 ILLINOIS FED. AID PROJECT				

SCALE: N/A SHEET NO. 1 OF 1 SHEETS STA. TO STA.

P:\2009\ME09006.Var-Ver-Phil\CADD\W022.US34.Shts\02-GNOTE.sht-US34.dgn

SUMMARY OF QUANTITIES				CONSTRUCTION TYPE CODE			
CODE NO.	ITEM DESCRIPTION	UNIT	TOTAL QUANTITY	URBAN			
				ROADWAY HSIP 90% FED 10% STATE	PED SIGNAL 50% STATE 25% COUNTY 25% CITY	SIDEWALK 80% STATE 20% CITY	TREE REPLACEMENT 100% CITY
				0005	0021	0021	0031
20100110	TREE REMOVAL (6 TO 15 UNITS DIAMETER)	UNIT	27	-	-	-	27
20200100	EARTH EXCAVATION	CU YD	1010	1010	-	-	-
20201200	REMOVAL AND DISPOSAL OF UNSUITABLE MATERIAL	CU YD	490	490	-	-	-
20400800	FURNISHED EXCAVATION	CU YD	25	25	-	-	-
20800150	TRENCH BACKFILL	CU YD	231.6	231.6	-	-	-
* 21101615	TOPSOIL FURNISH AND PLACE, 4"	SQ YD	1065	1065	-	-	-
* 25200110	SODDING, SALT TOLERANT	SQ YD	1065	1065	-	-	-
28000400	PERIMETER EROSION BARRIER	FOOT	500	500	-	-	-
28000510	INLET FILTERS	EACH	30	30	-	-	-
35501327	HOT-MIX ASPHALT BASE COURSE, 10 3/4"	SQ YD	919	919	-	-	-
40600200	BITUMINOUS MATERIALS (PRIME COAT)	TON	0.79	0.79	-	-	-
40600300	AGGREGATE (PRIME COAT)	TON	3.94	3.94	-	-	-
40603090	HOT-MIX ASPHALT BINDER COURSE, IL 19.0, N90	TON	544	544	-	-	-
40603595	POLYMERIZED HOT-MIX ASPHALT SURFACE COURSE, MIX "F", N90	TON	221	221	-	-	-
42001300	PROTECTIVE COAT	SQ YD	3435	3435	-	-	-
42400200	PORTLAND CEMENT CONCRETE SIDEWALK 5 INCH	SQ FT	2493	-	-	2493	-
42400800	DETECTABLE WARNINGS	SQ FT	48	-	-	48	-
44000157	HOT-MIX ASPHALT SURFACE REMOVAL, 2"	SQ YD	1068	1068	-	-	-
44000500	COMBINATION CURB AND GUTTER REMOVAL	FOOT	1205	1205	-	-	-
44003510	MEDIAN REMOVAL PARTIAL DEPTH	SQ FT	1850	1850	-	-	-
44201819	CLASS D PATCHES, TYPE III, 14 INCH	SQ YD	50	50	-	-	-
44201821	CLASS D PATCHES, TYPE IV, 14 INCH	SQ YD	194	194	-	-	-
44003100	MEDIAN REMOVAL	SQ FT	9570	9570	-	-	-
44000600	SIDEWALK REMOVAL	SQ FT	195	-	-	195	-
550A0050	STORM SEWERS, CLASS A, TYPE 1 12"	FOOT	21	21	-	-	-
550A0070	STORM SEWERS, CLASS A, TYPE 1 15"	FOOT	47	47	-	-	-
550A0160	STORM SEWERS, CLASS A, TYPE 1 36"	FOOT	252	252	-	-	-
550A4500	STORM SEWERS, CLASS A, TYPE 1 EQUIVALENT ROUND-SIZE 36"	FOOT	146	146	-	-	-
55100900	STORM SEWER REMOVAL 18"	FOOT	140	140	-	-	-
55101200	STORM SEWER REMOVAL 24"	FOOT	249	249	-	-	-
60255500	MANHOLES TO BE ADJUSTED	EACH	1	1	-	-	-
60200105	CATCH BASINS, TYPE A, 4'-DIAMETER, TYPE 1 FRAME, OPEN LID	EACH	1	1	-	-	-
60200205	CATCH BASINS, TYPE A, 4'-DIAMETER, TYPE 1 FRAME, CLOSED LID	EACH	1	1	-	-	-

SUMMARY OF QUANTITIES				CONSTRUCTION TYPE CODE			
CODE NO.	ITEM DESCRIPTION	UNIT	TOTAL QUANTITY	URBAN			
				ROADWAY HSIP 90% FED 10% STATE	PED SIGNAL 50% STATE 25% COUNTY 25% CITY	SIDEWALK 80% STATE 20% CITY	TREE REPLACEMENT 100% CITY
				0005	0021	0021	0031
60206905	CATCH BASINS, TYPE C, TYPE 1 FRAME, OPEN LID	EACH	4	4	-	-	-
60208240	CATCH BASINS, TYPE C, TYPE 24 FRAME AND GRATE	EACH	2	2	-	-	-
60211800	CATCH BASINS, TYPE D, 4'-DIAMETER, TYPE 1 FRAME, CLOSED LID	EACH	2	2	-	-	-
60223800	MANHOLES, TYPE A, 6'-DIAMETER, TYPE 1 FRAME, CLOSED LID	EACH	2	2	-	-	-
60236600	INLETS, TYPE A, TYPE 9 FRAME AND GRATE	EACH	2	2	-	-	-
60257900	MANHOLES TO BE RECONSTRUCTED	EACH	1	1	-	-	-
60300305	FRAMES AND LIDS TO BE ADJUSTED	EACH	2	2	-	-	-
60406100	FRAMES AND LIDS, TYPE 1, CLOSED LID	EACH	2	2	-	-	-
60605000	COMBINATION CONCRETE CURB AND GUTTER, TYPE B-6.24	FOOT	94	94	-	-	-
60619200	CONCRETE MEDIAN, TYPE SB-6.06	SQ FT	386	386	-	-	-
60619600	CONCRETE MEDIAN, TYPE SB-6.12	SQ FT	321	321	-	-	-
60624600	CORRUGATED MEDIAN	SQ FT	2910	2910	-	-	-
63700175	CONCRETE BARRIER, SINGLE FACE, 42 INCH HEIGHT	FOOT	166	166	-	-	-
* 66900200	NON-SPECIAL WASTE DISPOSAL	CU YD	5	5	-	-	-
* 66900450	SPECIAL WASTE PLANS AND REPORTS	L SUM	1	1	-	-	-
* 66900530	SOIL DISPOSAL ANALYSIS	EACH	1	1	-	-	-
67000400	ENGINEER'S FIELD OFFICE, TYPE A	CAL MO	6	6	-	-	-
67100100	MOBILIZATION	L SUM	1	1	-	-	-
70106800	CHANGEABLE MESSAGE SIGN	CAL MO	6	6	-	-	-
70300100	SHORT-TERM PAVEMENT MARKING	FOOT	530	530	-	-	-
70300210	TEMPORARY PAVEMENT MARKING - LETTERS AND SYMBOLS	SQ FT	36.4	36.4	-	-	-
70300220	TEMPORARY PAVEMENT MARKING - LINE 4"	FOOT	6630	6630	-	-	-
70300240	TEMPORARY PAVEMENT MARKING - LINE 6"	FOOT	350	350	-	-	-
70300520	PAVEMENT MARKING TAPE, TYPE III, 4"	FOOT	1000	1000	-	-	-
70301000	WORK ZONE PAVEMENT MARKING REMOVAL	SQ FT	88	88	-	-	-
* 78000100	THERMOPLASTIC PAVEMENT MARKING - LETTERS AND SYMBOLS	SQ FT	218.4	218.4	-	-	-
* 78000200	THERMOPLASTIC PAVEMENT MARKING - LINE 4"	FOOT	2125	2125	-	-	-
* 78000400	THERMOPLASTIC PAVEMENT MARKING - LINE 6"	FOOT	816	816	-	-	-
* 78000650	THERMOPLASTIC PAVEMENT MARKING - LINE 24"	FOOT	43	43	-	-	-
* 78100100	RAISED REFLECTIVE PAVEMENT MARKER	EACH	83	83	-	-	-
* 78300100	PAVEMENT MARKING REMOVAL	SQ FT	2065	2065	-	-	-
78300200	RAISED REFLECTIVE PAVEMENT MARKER REMOVAL	EACH	83	83	-	-	-

* SPECIALTY ITEM

Rev. 7-19-11

FILE NAME : P:\2009\ME09086_VerVar_PhilCADD\W022_US34_Sha\03-500sh-t-ht-US34.dgn
 PLOT SCALE : 1:1000 / IN
 USER NAME : Millenna Professional Services

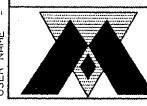

200 22ND Street, Suite 216, Lombard, IL 60148
 630.705.0110 voice, 630.839.2566 fax
 www.mps-il.com
MILLENNIA PROFESSIONAL SERVICES

DESIGNED - CJD	REVISED -
DRAWN - CJD	REVISED -
CHECKED - TVN	REVISED -
DATE - 6/1/2011	REVISED -

STATE OF ILLINOIS
DEPARTMENT OF TRANSPORTATION

US ROUTE 34
AT NORTH AURORA ROAD /RAYMOND DRIVE

SUMMARY OF QUANTITIES

SCALE: NTS SHEET NO. 1 OF 2 SHEETS STA. TO STA.

F.A.P. RTE. 311	SECTION 652X-N-3	COUNTY	TOTAL SHEETS 34	SHEET NO. 3
FED. ROAD DIST. NO. 1 (ILLINOIS) FED. AID PROJECT				CONTRACT NO. 60L22

P:\2009\ME09086_VerVar_PhilCADD\W022_US34_Sha\03-500sh-t-ht-US34.dgn

SUMMARY OF QUANTITIES

CONSTRUCTION TYPE CODE

URBAN

CODE NO.	ITEM DESCRIPTION	UNIT	TOTAL QUANTITY	CONSTRUCTION TYPE CODE			
				ROADWAY HSIP 90% FED 10% STATE	PED SIGNAL 50% STATE 25% COUNTY 25% CITY	SIDEWALK 80% STATE 20% CITY	TREE REPLACEMENT 100% CITY
				0005	0021	0021	0031
* 81000600	CONDUIT IN TRENCH, 2" DIA., GALVANIZED STEEL	FOOT	240		240	-	-
* 81400100	HANDHOLE	EACH	1		1	-	-
* 81603200	UNIT DUCT, 600V, 3-1C NO.2, 1/C NO.4 GROUND, (EPR-TYPE RHW), 1 1/4" DIA. POLYETHYLENE	FOOT	430		430	-	-
* 81900200	TRENCH AND BACKFILL FOR ELECTRICAL WORK	FOOT	650		650	-	-
* 84400105	RELOCATE EXISTING LIGHTING UNIT	EACH	2		2	-	-
* 87301215	ELECTRIC CABLE IN CONDUIT, SIGNAL, NO. 14 2C	FOOT	475		475	-	-
* 88102717	PEDESTRIAN SIGNAL HEAD, LED, 1-FACE, BRACKET MOUNTED WITH COUNTDOWN TIMER	EACH	4	-	4	-	-
* 88102747	PEDESTRIAN SIGNAL HEAD, LED, 2-FACE, BRACKET MOUNTED WITH COUNTDOWN TIMER	EACH	1	-	1	-	-
* 88600600	DETECTOR LOOP REPLACEMENT	FOOT	97	97	-	-	-
* 88800100	PEDESTRIAN PUSH-BUTTON	EACH	6	-	6	-	-
* 89502376	REBUILD EXISTING HANDHOLE	EACH	1		1	-	-
* 89502380	REMOVE EXISTING HANDHOLE	EACH	1		1	-	-
* A2000118	TREE, ACER X FREEMANII AUTUMN BLAZE (AUTUMN BLAZE FREEMAN MAPLE), 3" CALIPER, BALLED AND BURLAPPED	EACH	3	-	-	-	3
Δ X5539700	STORM SEWERS TO BE CLEANED	FOOT	144	144	-	-	-
X6061460	PAVED DITCH (SPECIAL)	FOOT	166	166	-	-	-
X7010216	TRAFFIC CONTROL AND PROTECTION (SPECIAL)	L SUM	1	1	-	-	-
* X8360120	LIGHT POLE FOUNDATION, SPECIAL	EACH	2	2	-	-	-
Z0001050	AGGREGATE SUBGRADE 12"	SO YD	1223	1223	-	-	-
Z0013302	SEGMENTAL CONCRETE BLOCK WALL	SO FT	575	575	-	-	-
Z0013798	CONSTRUCTION LAYOUT	L SUM	1	1	-	-	-
Z0018400	DRAINAGE STRUCTURES TO BE ADJUSTED	EACH	2	2	-	-	-
Δ Z0018500	DRAINAGE STRUCTURES TO BE CLEANED	EACH	18	18	-	-	-
Z0018700	DRAINAGE STRUCTURE TO BE REMOVED	EACH	2	2	-	-	-
Z0030850	TEMPORARY INFORMATION SIGNING	SO FT	104	104	-	-	-
* Z0033024	MAINTAIN EXISTING LIGHTING SYSTEM	L SUM	1	1	-	-	-
Z0048665	RAILROAD PROTECTIVE LIABILITY INSURANCE	L SUM	1	1	-	-	-

Δ Non-participating (100% State)

* SPECIALTY ITEM

FILE NAME = P:\2009\ME09026_Ver-Var-Phit\CADD\W022.US34\Sheets\03-S00\ht-ht-US34.dgn
 USER NAME = JN
 MILLENNIA PROFESSIONAL SERVICES



200 22ND Street, Suite 216, Lombard, IL 60148
 630.705.0110 voice, 630.839.2566 fax
 www.mps-ill.com

MILLENNIA PROFESSIONAL SERVICES

DESIGNED -	CJD	REVISED -	
DRAWN -	CJD	REVISED -	
CHECKED -	TVN	REVISED -	
DATE -	6/1/2011	REVISED -	

**STATE OF ILLINOIS
 DEPARTMENT OF TRANSPORTATION**

**US ROUTE 34
 AT NORTH AURORA ROAD /RAYMOND DRIVE**

SUMMARY OF QUANTITIES

F.A.P. RTE.	SECTION	COUNTY	TOTAL SHEETS	SHEET NO.
311	652X-N-3	DUPAGE	34	4
FED. ROAD DIST. NO. 1 ILLINOIS FED. AID PROJECT			CONTRACT NO. 60L22	

SCALE: NTS SHEET NO. 1 OF 2 SHEETS STA. TO STA.

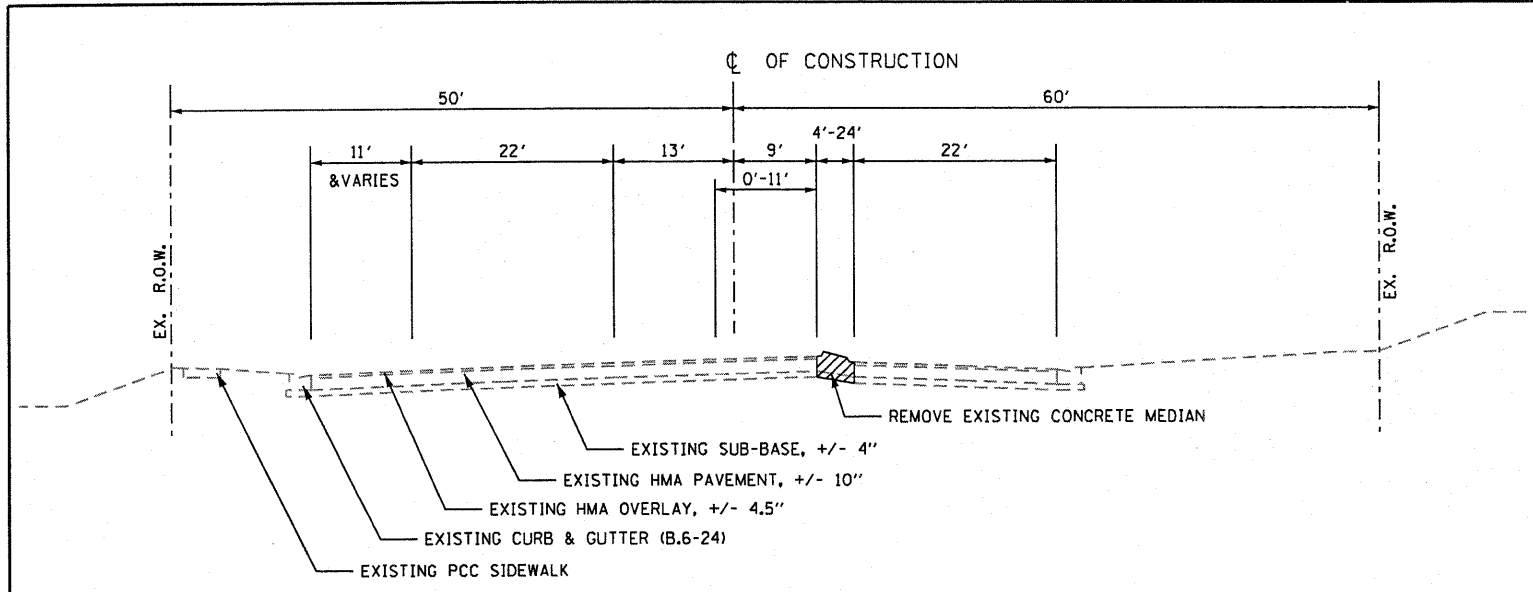

EXISTING TYPICAL SECTION
US ROUTE 34 (EAST LEG)
 STATION 114+32 TO STATION 118+94

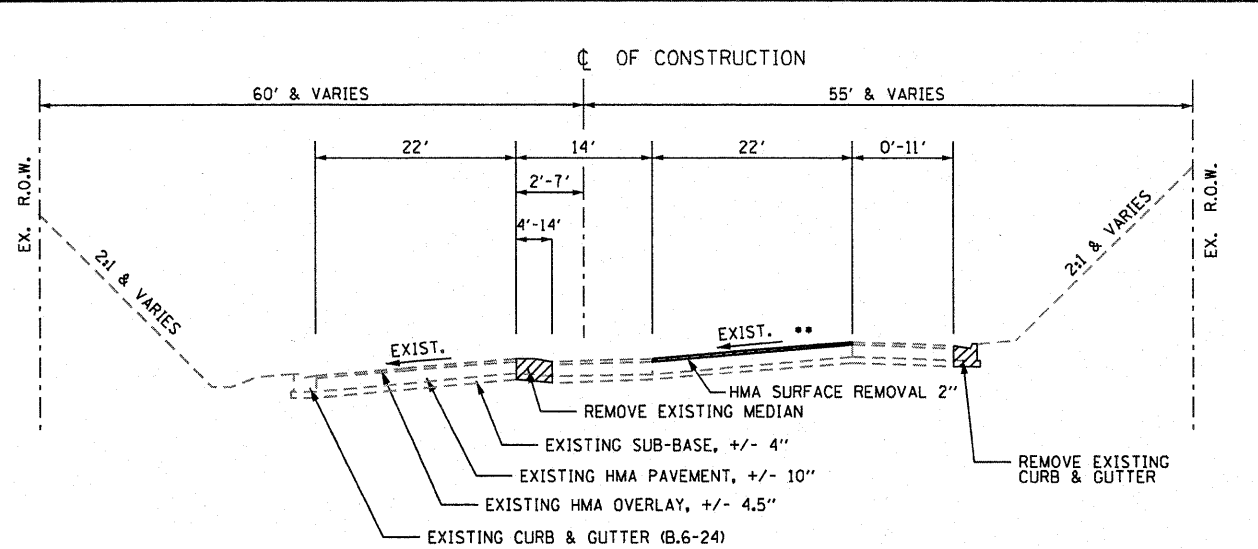

EXISTING TYPICAL SECTION
US ROUTE 34 (SOUTH LEG)
 STATION 503+44 TO STATION 507+50

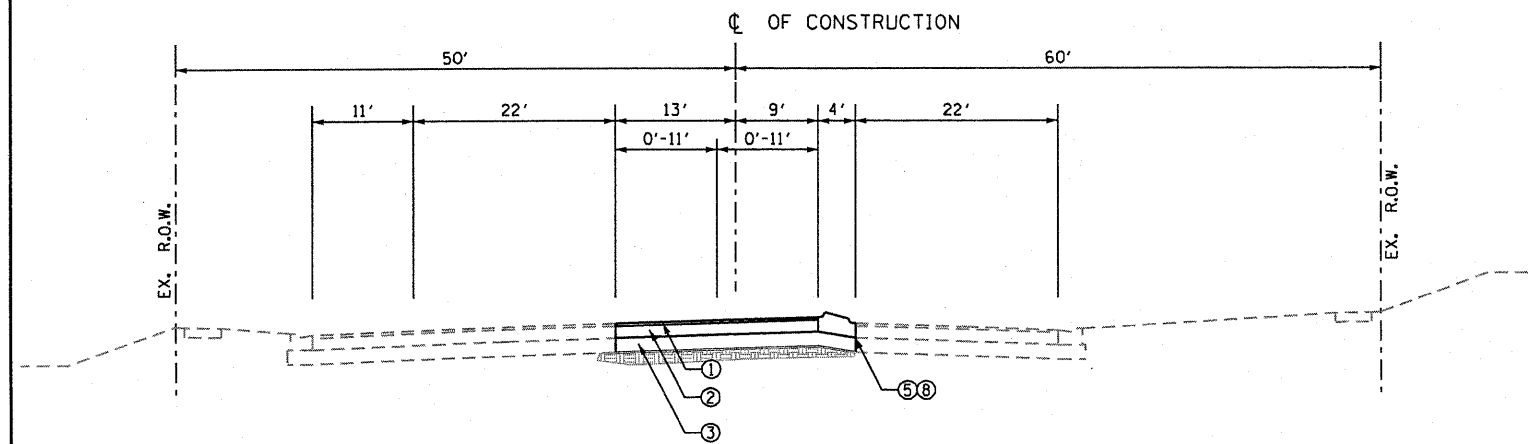

PROPOSED TYPICAL SECTION
US ROUTE 34 (EAST LEG)
 STATION 114+32 TO STATION 118+94

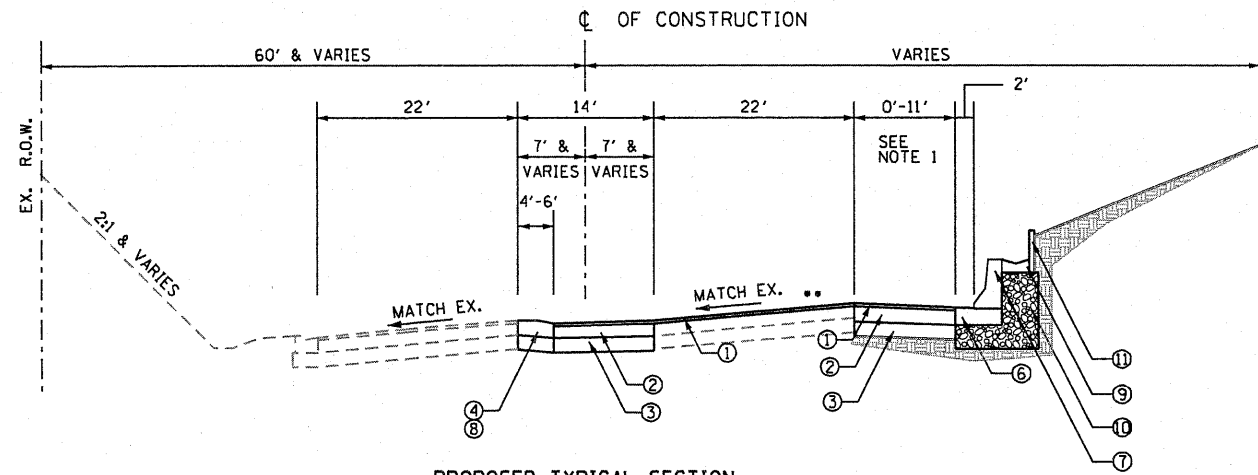

PROPOSED TYPICAL SECTION
US ROUTE 34 (SOUTH LEG)
 STATION 503+44 TO STATION 507+50
 ** RESURFACE LIMIT STA 501+80 TO 505+85

PROPOSED LEGEND

- ① 2" POLYMERIZED HMA SURFACE COURSE MIX F, N90
- ② 10 3/4" HMA BINDER COURSE, IL 19, N90 HMA BASE COURSE, 10 3/4"
- ③ 12" AGGREGATE SUBGRADE
- ④ CONCRETE MEDIAN, TYPE SB6.12
- ⑤ CONCRETE MEDIAN, TYPE SB6.06
- ⑥ CONCRETE BASE
- ⑦ 42" F SHAPED CONCRETE BARRIER
- ⑧ CONCRETE CORRUGATED MEDIAN
- ⑨ PAVED DITCH
- ⑩ GRANULAR BACK FILL
- ⑪ RETAINING WALL

NOTES

1. THE CONTRACTOR SHALL PERFORM THE PAVEMENT PATCHING OPERATIONS PRIOR TO THE HMA SURFACE REMOVAL OPERATION. SEE IDOT DISTRICT 1 DETAIL PAVEMENT PATCHING FOR HMA SURFACED PAVEMENT (BD-22) FOR ADDITIONAL INFORMATION.

HOT MIX ASPHALT MIXTURE REQUIREMENTS	
MIXTURE TYPE	AIR VOIDS @ Ndes
PAVEMENT RESURFACING	
HOT-MIX ASPHALT SURFACE COURSE, MIX "F", N90 (IL-9.5mm)	4% @ 90 GYR.
HOT-MIX ASPHALT BINDER COURSE, IL-19, N90	4% @ 90 GYR.
PATCHING	
CLASS D PATCHES (HMA BINDER IL-19 MM)	4% @ 70 GYR.
HMA REMOVAL OVER PATCHES (HMA BINDER IL-19MM)	4% @ 70 GYR.
BASE COURSE	
HMA BASE COURSE (HMA BINDER IL-19MM)	4% @ 90 GYR.

MIXTURE NOTES:

1. THE UNIT WEIGHT USED TO CALCULATE ALL HOT-MIX ASPHALT SURFACE MIXTURES IS 112 LBS/SQ YD/IN
2. THE "AC TYPE" FOR POLYMERIZED HMA MIXES SHALL BE "SBS/SBR PG70-22" AND FOR NON-POLYMERIZED HMA THE "AC TYPE" SHALL BE "PG 64-22" UNLESS MODIFIED BY DISTRICT ONE SPECIAL PROVISIONS. FOR "PERCENT OF RAP" SEE DISTRICT ONE SPECIAL PROVISIONS.

FILE NAME : P:\2009\ME9006_VerVer_Phil\CADD\W022.US34\Shs\04-DIG02-22-typl.dgn
 USER : Millennia Professional Services

KE 7-18-2011

200 22ND Street, Suite 216, Lombard, IL 60148
 630.795.0110 voice, 630.839.2566 fax
 www.mps-ill.com

MILLENNIA PROFESSIONAL SERVICES

DESIGNED - CJD	REVISED -
DRAWN - CJD	REVISED -
CHECKED - TVN	REVISED -
DATE - 6/20/2011	REVISED -

STATE OF ILLINOIS
DEPARTMENT OF TRANSPORTATION

US ROUTE 34
AT NORTH AURORA ROAD /RAYMOND DRIVE

SCALE: N/A SHEET NO. 1 OF 1 SHEETS STA. TO STA.

F.A.P. RTE. 311	SECTION 652X-N-3	COUNTY DUPAGE	TOTAL SHEETS 34	SHEET NO. 5
CONTRACT NO. 60L22				
FED. ROAD DIST. NO. 1 [ILLINOIS] FED. AID PROJECT				

P:\2009\ME9006_VerVer_Phil\CADD\W022.US34\Shs\04-DIG02-22-typl.dgn



EXIST. CURVE C2
 PI STA. = 509+29.82
 $\Delta = 31^\circ 06' 47''$ (LT)
 $D = 7^\circ 14' 17''$
 $R = 791.59'$
 $T = 220.37'$
 $L = 429.85'$
 $E = 30.10'$
 $e = \text{-----}$
 T.R. = -----
 S.E. RUN = -----
 P.C. STA. = 507+09.45
 P.T. STA. = 511+39.31

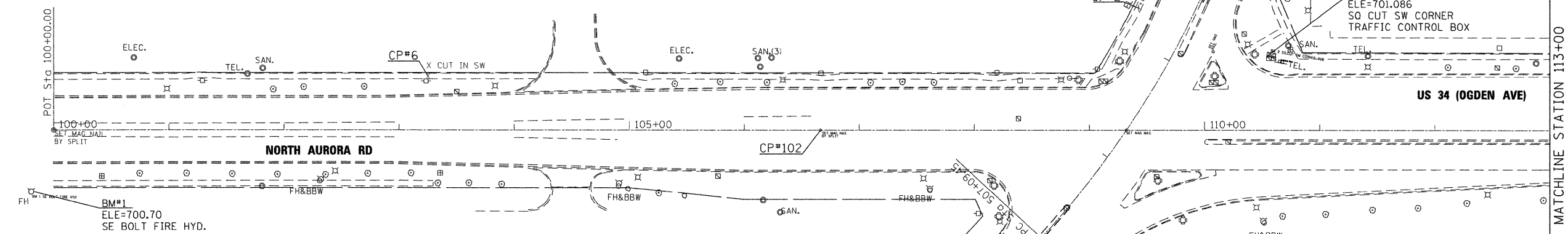

CONTROL POINTS AND BENCHMARKS

POINT	NORTH	EAST	STATION	OFFSET	ELEVATION	DESCRIPTION
2	1,862,572.736	1,025,092.794	509+28.82	44.85 LT	700.26	X CUT IN SW SURVEY POINT
4	1,862,587.417	1,025,821.137	116+62.89	3.37 RT	707.83	FND MAG NAIL SURVEY POINT
5	1,862,770.844	1,026,239.629	121+20.36	44.90 LT	706.99	X CUT IN SW SURVEY POINT
6	1,862,409.673	1,024,494.142	103+25.05	47.05 LT	698.82	X CUT IN SW SURVEY POINT
50	1,862,172.585	1,024,966.713	505+11.79	40.56 RT	694.15	SET 5/8 REBAR
102	1,862,421.086	1,024,838.579	106+66.45	0.000	698.55	FND MAG NAIL BY SPLIT PDT
110	1,861,822.600	1,024,585.242	500+00.00	0.000	694.21	FND IRON ROD W/CAP PDT

MATCHLINE STATION 506+00
 SEE SHEET NO. AT-02

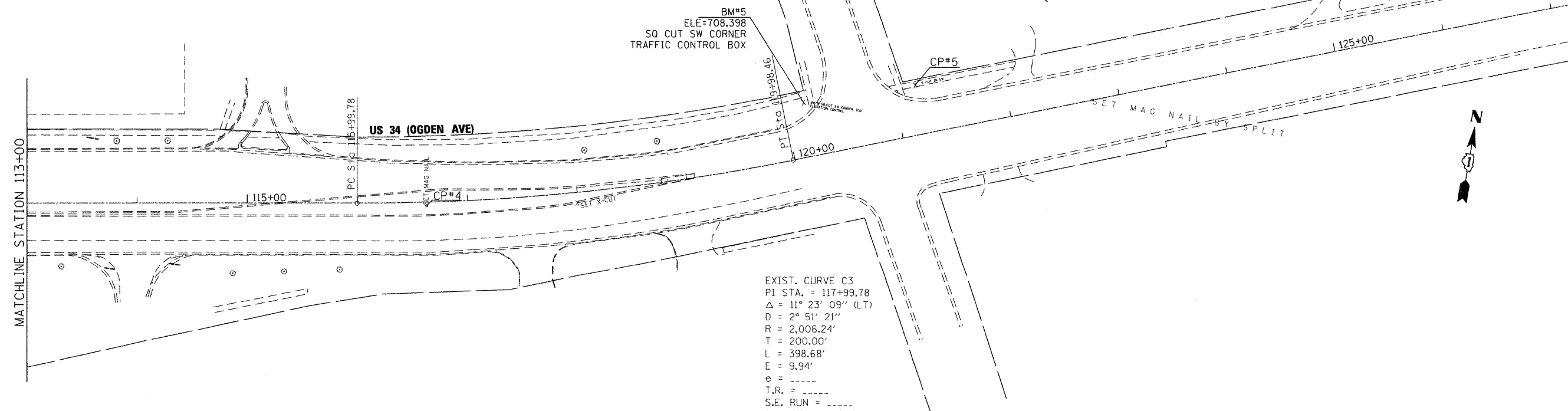

EXIST. CURVE C3
 PI STA. = 117+99.78
 $\Delta = 11^\circ 23' 09''$ (LT)
 $D = 2^\circ 51' 21''$
 $R = 2,006.24'$
 $T = 200.00'$
 $L = 398.68'$
 $E = 9.94'$
 $e = \text{-----}$
 T.R. = -----
 S.E. RUN = -----
 P.C. STA. = 115+99.78

FILE NAME = P:\2009\ME99086_Ver-Vor_P\IT\CADD\W022_US34\Sheet\DI60L22-AT01.dgn
 PLOT SCALE = 50.0000 / IN.
 USER NAME = Millennium Professional Services

MILLENNIA PROFESSIONAL SERVICES
 200 22ND Street, Suite 216, Lombard, IL 60148
 630.795.9118 voice, 630.839.2566 fax
 www.mps-ill.com

DESIGNED - CJD	REVISED -
DRAWN - CJD	REVISED -
CHECKED - TVN	REVISED -
DATE - 5/27/2011	REVISED -

STATE OF ILLINOIS
DEPARTMENT OF TRANSPORTATION

US ROUTE 34
AT NORTH AURORA ROAD /RAYMOND DRIVE
 SCALE: 1"=50' SHEET NO. 1 OF 2 SHEETS STA. 100+00 TO STA. 115+99.78

F.A.P. RTE.	SECTION	COUNTY	TOTAL SHEETS	SHEET NO.
311	652X-N-3	DUPAGE	34	6
CONTRACT NO. 60L22				

AT-01

US ROUTE 34(OGDEN AVE/RAYMOND DR) ALIGNMENT
 =====
 POINT 110 N 1,861,822.600 E 1,024,585.242 STA = 500+00.00

CURVE C1
 P.I. STATION 504+71.67 N 1,862,161.347 E 1,024,913.448
 DELTA = 11° 08' 02" (LT)
 DEGREE = 5° 19' 17"
 TANGENT = 104.948
 LENGTH = 209.234
 RADIUS = 1,076.729
 EXTERNAL = 5.102
 LONG CHORD = 208.905
 MID. ORD. = 5.078
 P.C. STATION = 503+66.72 N 1,862,085.974 E 1,024,840.420
 P.T. STATION = 505+75.95 N 1,862,249.402 E 1,024,970.546

CURVE C2
 P.I. STATION 509+29.82 N 1,862,546.315 E 1,025,163.073
 DELTA = 31° 06' 47" (LT)
 DEGREE = 7° 14' 17"
 TANGENT = 220.368
 LENGTH = 429.852
 RADIUS = 791.588
 EXTERNAL = 30.101
 LONG CHORD = 424.590
 MID. ORD. = 28.999
 P.C. STATION = 507+09.45 N 1,862,361.416 E 1,025,043.179
 P.T. STATION = 511+39.31 N 1,862,766.568 E 1,025,170.178

POINT 104 N 1,863,707.518 E 1,025,200.533 STA = 520+80.75
 =====

NORTH AURORA/OGDEN AVENUE ALIGNMENT
 =====
 POINT 103 N 1,862,308.281 E 1,024,181.748 STA = 100+00.00

CURVE C3
 P.I. STATION 117+99.78 N 1,862,612.918 E 1,025,955.558
 DELTA = 11° 23' 09" (LT)
 DEGREE = 2° 51' 21"
 TANGENT = 200.000
 LENGTH = 398.683
 RADIUS = 2,006.240
 EXTERNAL = 9.944
 LONG CHORD = 398.027
 MID. ORD. = 9.895
 P.C. STATION = 115+99.78 N 1,862,579.065 E 1,025,758.444
 P.T. STATION = 119+98.46 N 1,862,685.017 E 1,026,142.110

POINT 100 N 1,862,991.474 E 1,026,935.037 STA = 128+48.55
 =====

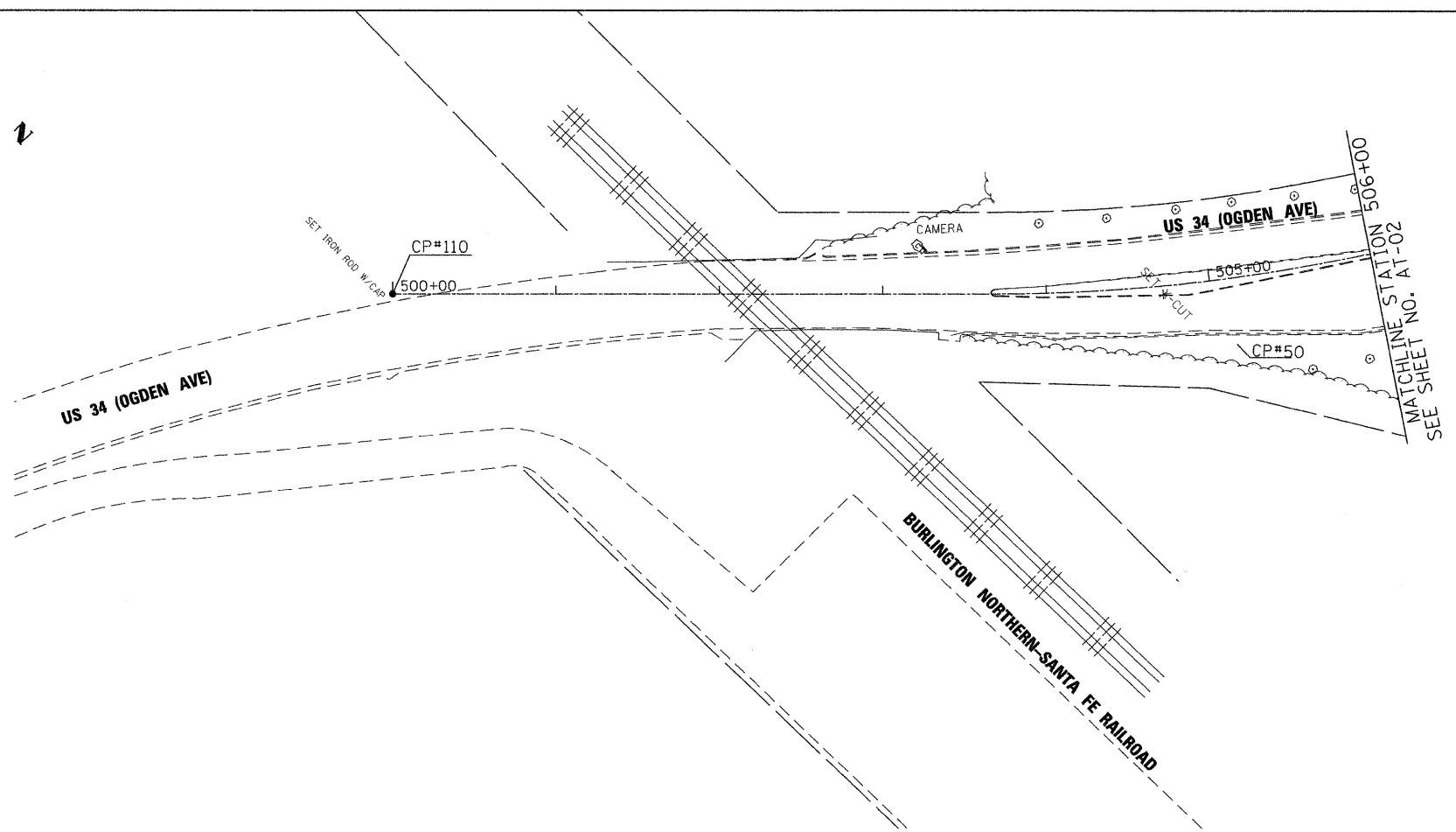

FILE NAME = P:\2009\ME9906E_Ver-Vor_PNT\CADD\W022_US34\Shets\168L22-AT02.dgn
 PLOT SCALE = 50.0000 / IN.
 USER NAME = Millennia Professional Services

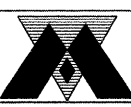

200 22ND Street, Suite 216, Lombard, IL 60148
 630.785.8118 voice, 630.839.2566 fax
 www.mps-il.com

MILLENNIA PROFESSIONAL SERVICES

DESIGNED - CJD	REVISED -
DRAWN - CJD	REVISED -
CHECKED - TVN	REVISED -
DATE - 5/27/2011	REVISED -

**STATE OF ILLINOIS
 DEPARTMENT OF TRANSPORTATION**

**US ROUTE 34
 AT NORTH AURORA ROAD /RAYMOND DRIVE**

ALIGNMENT, TIES AND BENCHMARKS

SCALE: 1"=50' SHEET NO. 2 OF 2 SHEETS STA. 500+00 TO STA. 506+00

F.A.P. RTE. 311	SECTION 652X-N-3	COUNTY DUPAGE	TOTAL SHEETS 34	SHEET NO. 7
CONTRACT NO. 60L22			FED. ROAD DIST. NO. 1 (ILLINOIS) FED. AID PROJECT	

AT-02

P:\2009\ME9906E_Ver-Vor_PNT\CADD\W022_US34\Shets\168L22-AT02.dgn

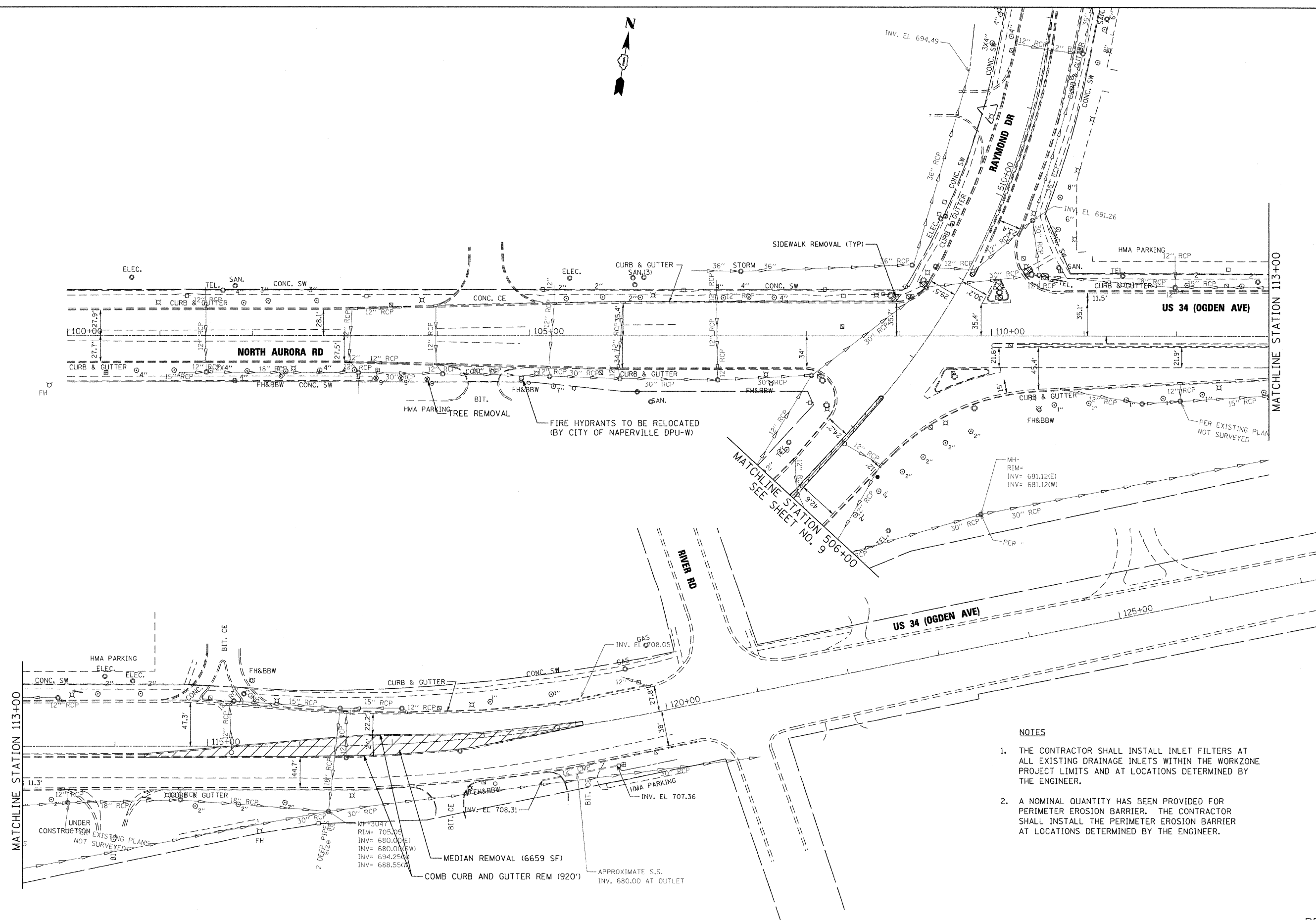

- NOTES**
1. THE CONTRACTOR SHALL INSTALL INLET FILTERS AT ALL EXISTING DRAINAGE INLETS WITHIN THE WORKZONE PROJECT LIMITS AND AT LOCATIONS DETERMINED BY THE ENGINEER.
 2. A NOMINAL QUANTITY HAS BEEN PROVIDED FOR PERIMETER EROSION BARRIER. THE CONTRACTOR SHALL INSTALL THE PERIMETER EROSION BARRIER AT LOCATIONS DETERMINED BY THE ENGINEER.

FILE NAME = P:\2009\ME09006_Ver-Yar-Phit\CADD\W022-US34\Sheet\DI60L22-EX01.dgn
 PLOT SCALE = 5/8"=1'-0" / IN.
 USER NAME = Millennium Professional Services



200 22ND Street, Suite 216, Lombard, IL 60148
 630.705.9110 voice, 630.839.2566 fax
 www.mps-il.com
MILLENNIA PROFESSIONAL SERVICES

DESIGNED - CJD	REVISED -
DRAWN - CJD	REVISED -
CHECKED - TVN	REVISED -
DATE - 5/31/2011	REVISED -

STATE OF ILLINOIS
DEPARTMENT OF TRANSPORTATION

US ROUTE 34
AT NORTH AURORA ROAD /RAYMOND DRIVE

REMOVAL PLAN
 SCALE: 1"=50' SHEET NO. 1 OF 2 SHEETS STA. 100+00 TO STA. 121+00

F.A.P. RTE. 311	SECTION 652X-N-3	COUNTY DUPAGE	TOTAL SHEETS 34	SHEET NO. 8
FED. ROAD DIST. NO. 1 [ILLINOIS] FED. AID PROJECT			CONTRACT NO. 60L22	

REM-01

P:\2009\ME09006_Ver-Yar-Phit\CADD\W022-US34\Sheet\DI60L22-EX01.dgn

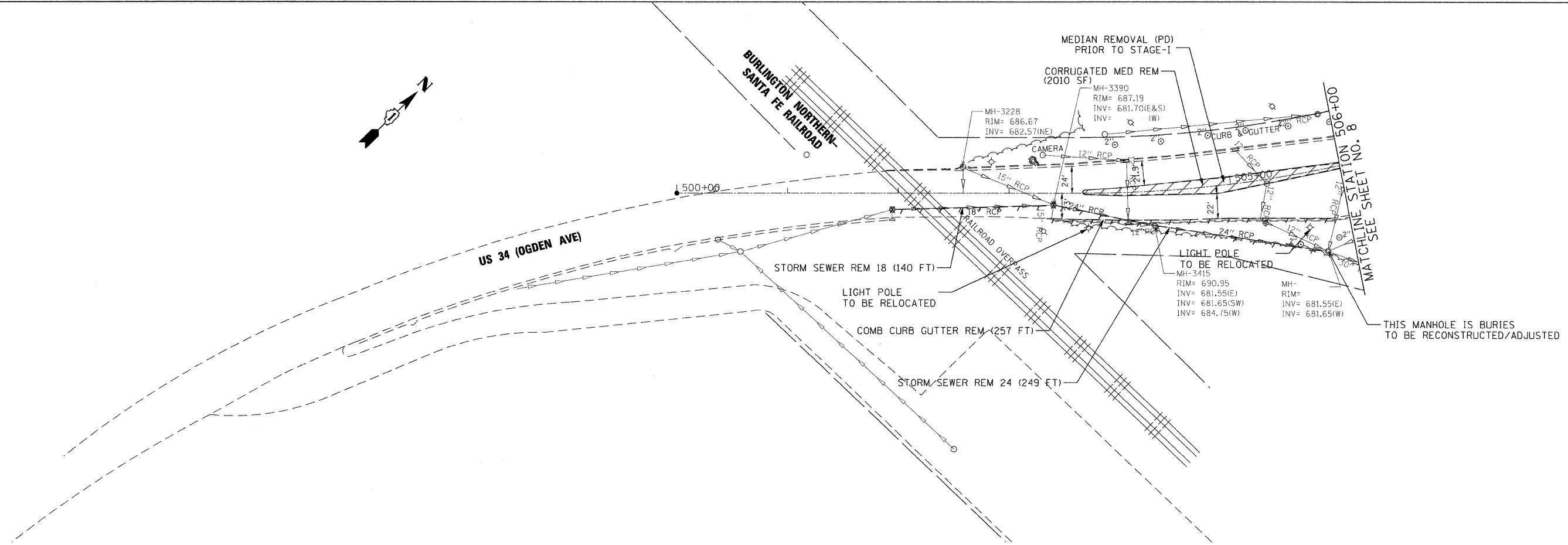

THIS MANHOLE IS BURIES TO BE RECONSTRUCTED/ADJUSTED

NOTES

1. THE CONTRACTOR SHALL INSTALL INLET FILTERS AT ALL EXISTING DRAINAGE INLETS WITHIN THE WORKZONE PROJECT LIMITS AND AT LOCATIONS DETERMINED BY THE ENGINEER.
2. A NOMINAL QUANTITY HAS BEEN PROVIDED FOR PERIMETER EROSION BARRIER. THE CONTRACTOR SHALL INSTALL THE PERIMETER EROSION BARRIER AT LOCATIONS DETERMINED BY THE ENGINEER.

FILE NAME : F:\2009\ME\9006.Var\Var\PHI\CADD\W022-US34\Shts\0160L22-EX02.dgn
 USER NAME : PHILIPPA Professional Services

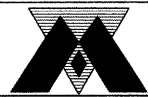

200 22ND Street, Suite 216, Lombard, IL 60148
 630.705.0110 voice, 630.839.2566 fax
 www.mps-ll.com
MILLENNIA PROFESSIONAL SERVICES

DESIGNED -	CJD	REVISED -	
DRAWN -	CJD	REVISED -	
CHECKED -	TVN	REVISED -	
DATE -	5/31/2011	REVISED -	

STATE OF ILLINOIS
DEPARTMENT OF TRANSPORTATION

US ROUTE 34
AT NORTH AURORA ROAD /RAYMOND DRIVE
 SCALE: 1"=50' SHEET NO. 2 OF 2 SHEETS STA. 500+00 TO STA. 506+00

F.A.P. RTE.	SECTION	COUNTY	TOTAL SHEETS	SHEET NO.
311	652X-N-3	DUPAGE	34	9
CONTRACT NO. 60L22			FED. AID PROJECT	

REM-02

F:\2009\ME\9006.Var\Var\PHI\CADD\W022-US34\Shts\0160L22-EX02.dgn

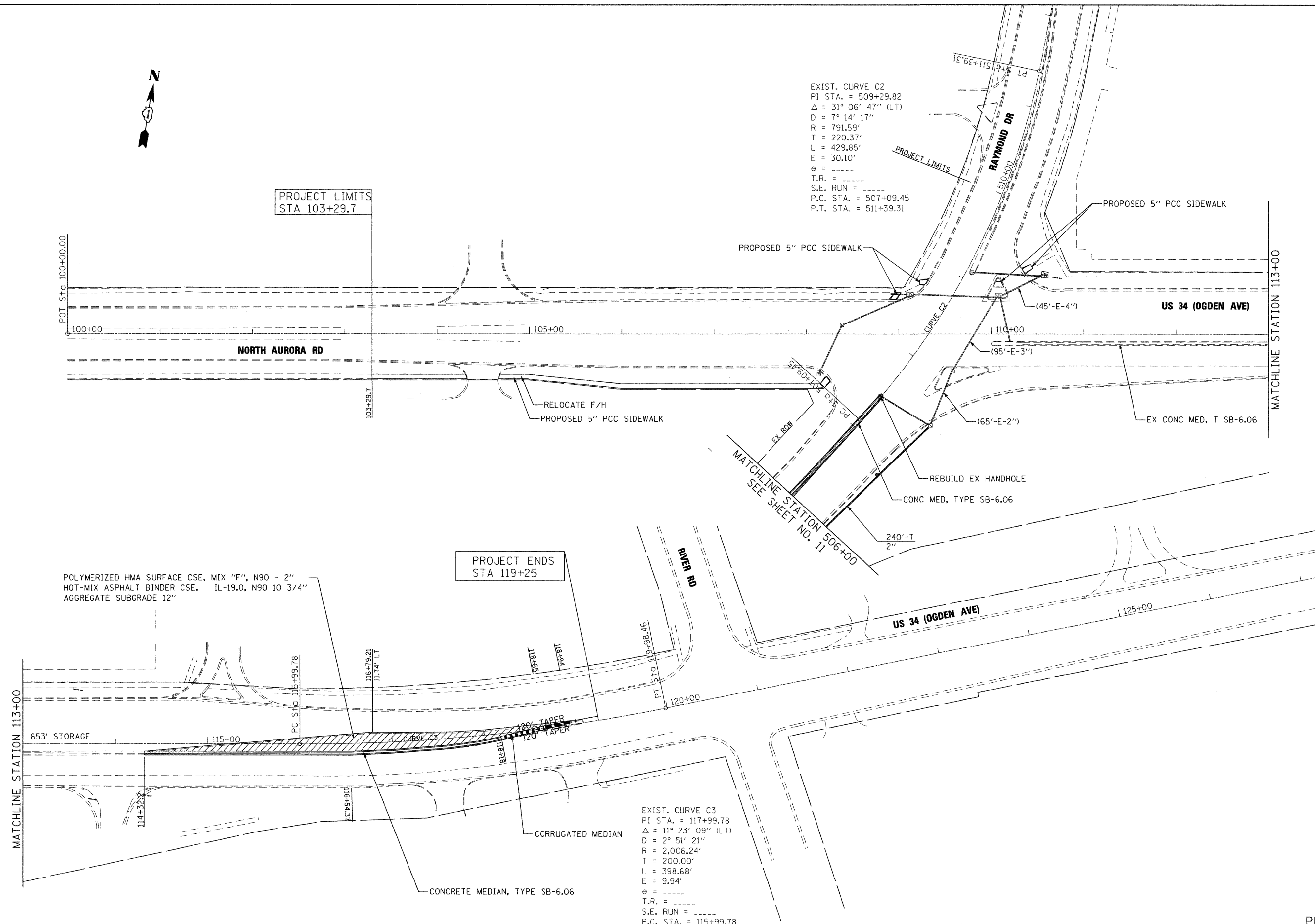

FILE NAME = P:\2009\ME\09006_Ver-Vor_Pht\CADD\W022.US34.Sh1a.D160L22-PRP01.dgn
 PLOT SCALE = 50.00000 / IN.
 USER NAME = Millennium Professional Services



200 22ND Street, Suite 216, Lombard, IL 60148
 630.795.0110 voice, 630.839.3566 fax
 www.mps-il.com
MILLENNIA PROFESSIONAL SERVICES

DESIGNED - CJD	REVISED -
DRAWN - CJD	REVISED -
CHECKED - TVN	REVISED -
DATE - 5/31/2011	REVISED -

STATE OF ILLINOIS
DEPARTMENT OF TRANSPORTATION

US ROUTE 34
AT NORTH AURORA ROAD /RAYMOND DRIVE

SCALE: 1"=50' SHEET NO. 1 OF 2 SHEETS STA. 103+29.7 TO STA. 119+25

F.A.P. RTE. 311	SECTION 652X-N-3	COUNTY	TOTAL SHEETS 34	SHEET NO. 10
FED. ROAD DIST. NO. 1 ILLINOIS FED. AID PROJECT		CONTRACT NO. 60L22		

PLN-01

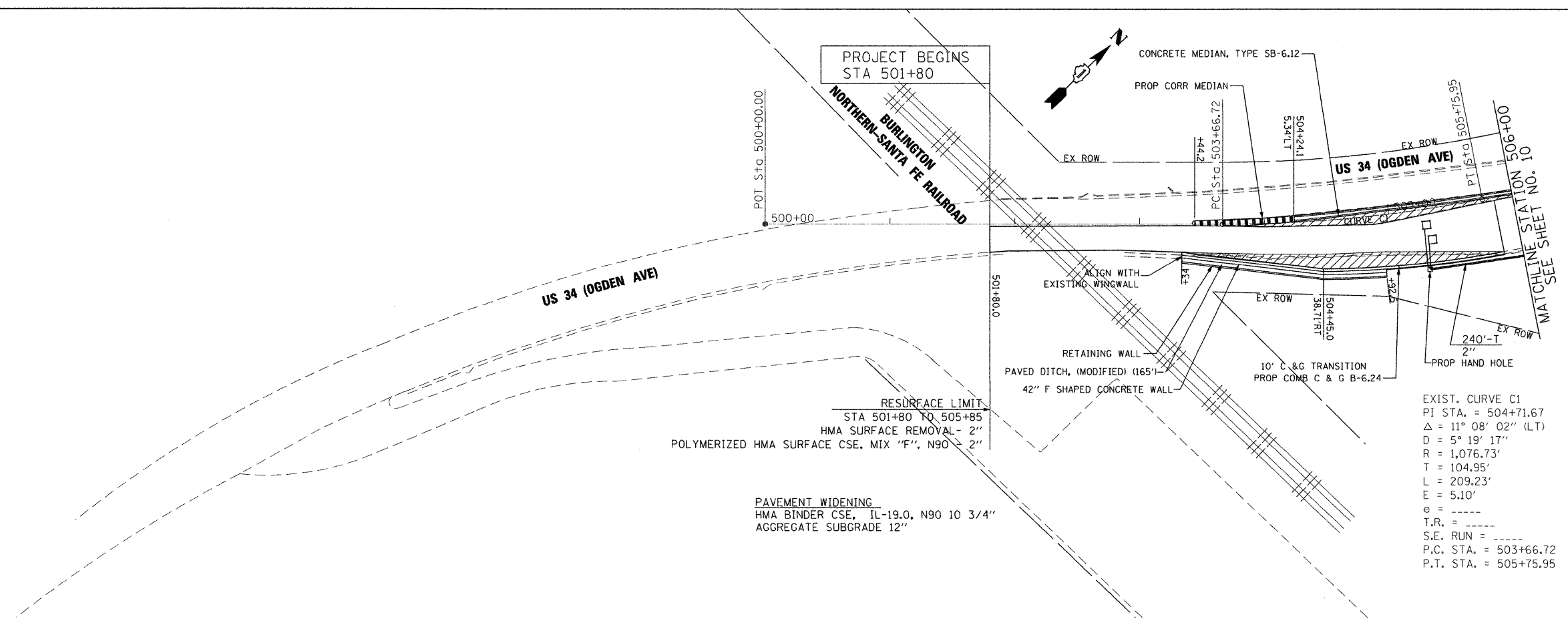

RESURFACE LIMIT
 STA 501+80 TO 505+85
 HMA SURFACE REMOVAL - 2"
 POLYMERIZED HMA SURFACE CSE, MIX "F", N90 - 2"

PAVEMENT WIDENING
 HMA BINDER CSE, IL-19.0, N90 10 3/4"
 AGGREGATE SUBGRADE 12"

EXIST. CURVE C1
 PI STA. = 504+71.67
 $\Delta = 11^\circ 08' 02''$ (LT)
 D = 5° 19' 17"
 R = 1,076.73'
 T = 104.95'
 L = 209.23'
 E = 5.10'
 e = -----
 T.R. = -----
 S.E. RUN = -----
 P.C. STA. = 503+66.72
 P.T. STA. = 505+75.95

FILE NAME = P:\2009\ME09005_Ver-Ver- PH1\CADD\W022.US34\Sheet\DI60L22-PR02.dgn
 PLOT SCALE = 50.00000 / IN.
 USER NAME = Millennium Professional Services

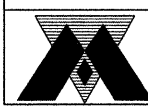

200 22ND Street, Suite 216, Lombard, IL 60148
 630.795.0110 voice, 630.839.2566 fax
 www.mps-il.com

MILLENNIA PROFESSIONAL SERVICES

DESIGNED - CJD	REVISED -
DRAWN - CJD	REVISED -
CHECKED - TVN	REVISED -
DATE - 5/31/2011	REVISED -

**STATE OF ILLINOIS
 DEPARTMENT OF TRANSPORTATION**

**US ROUTE 34
 AT NORTH AURORA ROAD /RAYMOND DRIVE**

SCALE: 1"=50' SHEET NO. OF SHEETS STA. 501+80 TO STA. 506+00

F.A.P. RTE. 311	SECTION 652X-N-3	COUNTY DUPAGE	TOTAL SHEETS 34	SHEET NO. 11
CONTRACT NO. 60L22			FED. ROAD DIST. NO. 1 (ILLINOIS) FED. AID PROJECT	

PLN-02

P:\2009\ME09005_Ver-Ver- PH1\CADD\W022.US34\Sheet\DI60L22-PR02.dgn

MAINTENANCE OF TRAFFIC GENERAL NOTES

1. THE SUGGESTED STAGES OF CONSTRUCTION AND TRAFFIC CONTROL PLANS SHALL SERVE AS A GUIDE FOR SAFE DIVERSION OF TRAFFIC DURING EXECUTION OF THIS CONTRACT. HOWEVER, THE CONTRACTOR MAY IMPROVE OR MODIFY THE TRAFFIC CONTROL PLANS TO MEET CONSTRUCTION NEEDS BUT NOT AT THE EXPENSE OF PUBLIC SAFETY OR CONVENIENCE. ANY CHANGES TO THE TRAFFIC CONTROL PLAN SHALL BE SUBMITTED TO THE ENGINEER FOR APPROVAL.
2. THE CONTRACTOR SHALL BE REQUIRED TO MAINTAIN TRAFFIC IN ACCORDANCE WITH THE TRAFFIC CONTROL PLANS, SPECIAL PROVISIONS, APPLICABLE STATE STANDARDS, AND AS DIRECTED BY THE ENGINEER.
3. CONTRACTOR SHALL MAINTAIN A MINIMUM OF ONE THROUGH LANE IN EACH DIRECTION THROUGH OUT THE PROJECT AREA AT ALL TIMES.
4. THE ENGINEER SHALL BE INFORMED 48 HOURS IN ADVANCE OF ANY CHANGE TO THE SUGGESTED STAGES OF CONSTRUCTION AND TRAFFIC CONTROL PLANS
5. TYPE II BARRICADES OR DRUMS SHALL BE PROVIDED AS SHOWN IN THE PLANS AND SPACED 50 FEET CENTER TO CENTER ON TANGENT, AND 25 FEET CENTER TO CENTER ON TAPERS AND CURVES.
6. THE CONTRACTOR SHALL PROVIDE ADEQUATE TEMPORARY DRAINAGE AND EROSION CONTROL PROTECTION DURING ALL PHASES OF CONSTRUCTION.
7. ALL EXISTING SIGNS THAT CONFLICT WITH THE TRAFFIC CONTROL PLAN SHALL BE COVERED OR REMOVED IN ACCORDANCE WITH ARTICLE 107.25 OF THE STANDARD SPECIFICATIONS.
8. THE CONTRACTOR SHALL PROVIDE, INSTALL, MAINTAIN AND REMOVE ALL SIGNS AND SIGN SUPPORTS REQUIRED FOR TRAFFIC CONTROL AND PROTECTION.
9. THE CONTRACTOR SHALL PLACE A CHANGEABLE MESSAGE SIGN AT EACH END OF THE PROJECT AND/OR AS DIRECTED BY THE ENGINEER TO INFORM MOTORISTS OF UPCOMING CONSTRUCTION ACTIVITIES. THE MESSAGE SIGNS WITH THE APPROPRIATE INFORMATION SHALL BE IN PLACED TWO WEEKS BEFORE START OF CONSTRUCTION ACTIVITY. THIS WORK IS TO BE PAID FOR AT THE CONTRACT UNIT PRICE PER CALENDAR MONTH, "CHANGEABLE MESSAGE SIGN".
10. THE CONTRACTOR SHALL MAINTAIN THE EROSION CONTROL MEASURES DURING CONSTRUCTION.

SEQUENCE OF CONSTRUCTION

PRE-STAGE

1. INSTALL EROSION CONTROL MEASURES.
2. MILL EXISTING CORRUGATED MEDIAN LOCATED AT THE SOUTH LEG OF THE INTERSECTION PER REMOVAL PLAN.
3. PLACE STAGE I TRAFFIC CONTROL DEVICES AND TEMPORARY PAVEMENT MARKINGS PER PLAN.

UTILIZE IDOT STANDARD TRAFFIC CONTROL STANDARDS TO MAINTAIN TRAFFIC.

STAGE I

1. REMOVE EXISTING MEDIAN ALONG EAST LEG OF INTERSECTION AND EXTEND STORAGE LENGTH OF THE EXISTING DUAL LEFT TURN LANES. WIDEN EXISTING PAVEMENT TO ACCOMMODATE ADDITIONAL STORAGE AND CONSTRUCT NEW MEDIAN.
2. WIDEN PAVEMENT AT THE SOUTH LEG FOR RIGHT TURN LANE STORAGE EXTENSION.
3. REMOVE AND REPLACE EXISTING STORM SEWER AND DRAINAGE STRUCTURES AT THE SOUTH LEG PER PLAN.
4. CONSTRUCT PAVEMENT PATCHING PER PLAN.
5. RELOCATE EXISTING LIGHT POLES PER PLAN.
6. INSTALL PROPOSED RETAINING WALL AT THE SOUTH LEG PER PLAN.
7. INSTALL PROPOSED SIDEWALK ON THE WEST LEG AND AT THE INTERSECTION PER PLAN.
8. SEE SUGGESTED STAGES OF CONSTRUCTION PLANS TO MAINTAIN TRAFFIC.

REMOVE STAGE I TRAFFIC CONTROL AND PLACE STAGE II TRAFFIC CONTROL DEVICES AND TEMPORARY PAVEMENT MARKINGS PER PLAN. UTILIZE IDOT STANDARD TRAFFIC CONTROL STANDARDS TO MAINTAIN TRAFFIC.

STAGE II

1. REMOVE EXISTING MEDIAN ALONG SOUTH LEG OF INTERSECTION AND EXTEND STORAGE LENGTH OF THE EXISTING LEFT TURN LANE. WIDEN EXISTING PAVEMENT TO ACCOMMODATE ADDITIONAL STORAGE AND CONSTRUCT NEW MEDIAN.

SEE SUGGESTED STAGES OF CONSTRUCTION PLANS TO MAINTAIN TRAFFIC.
2. MILL AND RESURFACE NORTHBOUND SOUTH LEG PER PLAN.
3. INSTALL PEDIESTRIAN SIGNALS AT THE INTERSECTION PER PLAN.
4. INSTALL PERMANENT PAVEMENT MARKING AND LANDSCAPING PER PLAN.

UTILIZE IDOT STANDARD TRAFFIC CONTROL STANDARDS TO MAINTAIN TRAFFIC.

FILE NAME = P:\2009\ME09086_Ver-Var- PH1\CADD\W022_US34\Shets\DI60L22-Std-Notes.dgn
 PLOT SCALE = 1:8000 / IN.
 USER NAME = Millennia Professional Services



200 22ND Street, Suite 216, Lombard, IL 60148
 630.705.9110 voice, 630.839.2566 fax
 www.mps-il.com

MILLENNIA PROFESSIONAL SERVICES

DESIGNED -	CJD	REVISED -	
DRAWN -	CJD	REVISED -	
CHECKED -	TVN	REVISED -	
DATE -	5/31/2011	REVISED -	

**STATE OF ILLINOIS
 DEPARTMENT OF TRANSPORTATION**

**US ROUTE 34
 AT NORTH AURORA ROAD /RAYMOND DRIVE**

**SUGGESTED STAGES OF CONSTRUCTION
 AND TRAFFIC CONTROL
 GENERAL NOTES AND DESCRIPTION**

SCALE: N/A SHEET NO. OF SHEETS STA. TO STA.

F.A.P. RTE.	SECTION	COUNTY	TOTAL SHEETS	SHEET NO.
311	652X-N-3	DUPAGE	34	12
FED. ROAD DIST. NO. 1 ILLINOIS FED. AID PROJECT			CONTRACT NO. 60L22	

P:\2009\ME09086_Ver-Var- PH1\CADD\W022_US34\Shets\DI60L22-Std-Notes.dgn

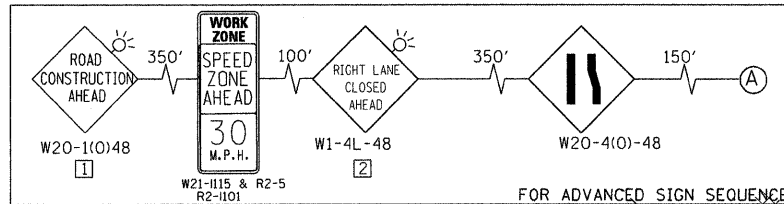

END CONSTRUCTION

TEMPORARY PAVEMENT MARKING- LINE 4"
TEMPORARY PAVEMENT MARKING- LINE 4" (2@11"C-C)

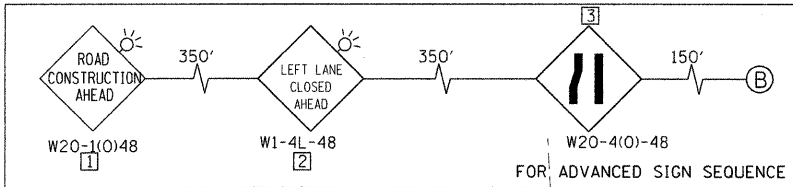
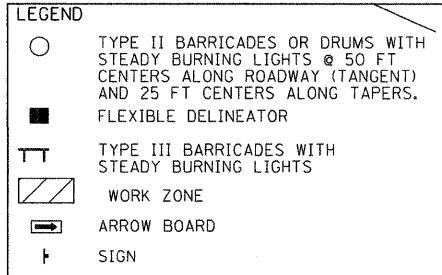

SEE ADVANCE SIGN SEQUENCE

MATCHLINE STATION 111+00
US 34 (OGDEN AVE)

FILE NAME : P:\2009\ME09006_Ver-Vor-Phil\CADD\W022.US34\Shrs\0160L22-STG01.dgn
 PLOT SCALE : 50.00000 / IN.
 USER NAME : Millennium Professional Services

200 22ND Street, Suite 216, Lombard, IL 60148
 630.795.0110 voice, 630.839.3566 fax
 www.mps-il.com
MILLENNIA PROFESSIONAL SERVICES

DESIGNED - CJD	REVISED -
DRAWN - CJD	REVISED -
CHECKED - TVN	REVISED -
DATE - 5/31/2011	REVISED -

STATE OF ILLINOIS
DEPARTMENT OF TRANSPORTATION

US ROUTE 34
AT NORTH AURORA ROAD / RAYMOND DRIVE

SUGGESTED STAGES OF CONSTRUCTION
AND TRAFFIC CONTROL
STAGE 1

F.A.P. RTE. 311	SECTION 652X-N-3	COUNTY DUPAGE	TOTAL SHEETS 34	SHEET NO. 13
FED. ROAD DIST. NO. 1 ILLINOIS FED. AID PROJECT			CONTRACT NO. 60L22	

STG-01

P:\2009\ME09006_Ver-Vor-Phil\CADD\W022.US34\Shrs\0160L22-STG01.dgn

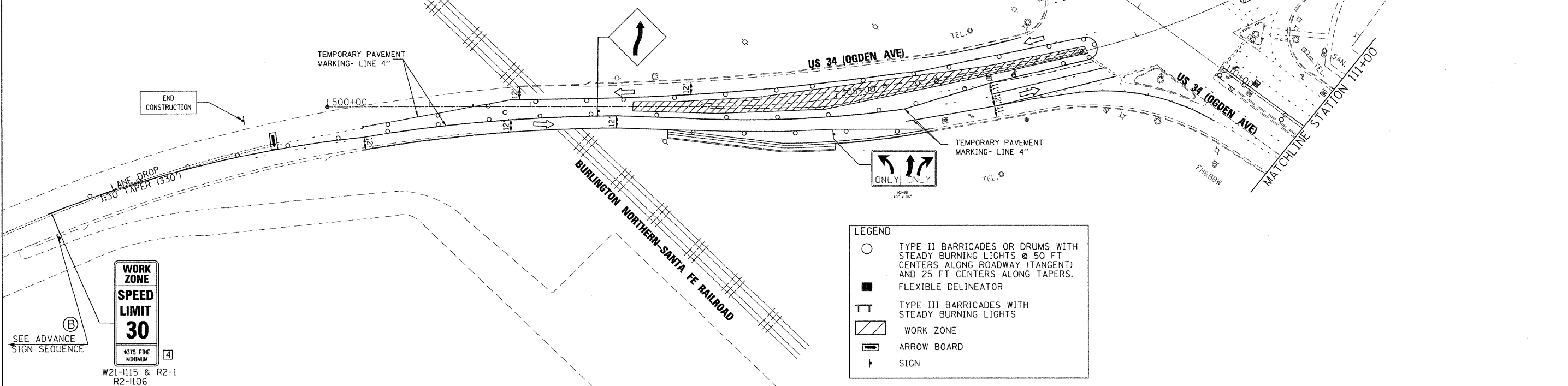
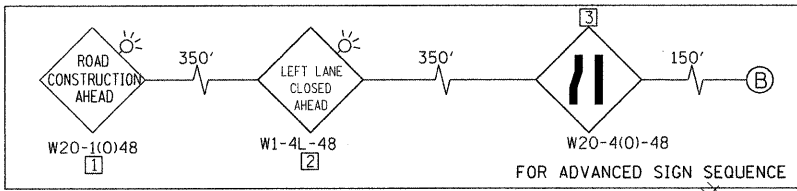

LEGEND

- TYPE II BARRICADES OR DRUMS WITH STEADY BURNING LIGHTS @ 50 FT CENTERS ALONG ROADWAY (TANGENT) AND 25 FT CENTERS ALONG TAPERS.
- FLEXIBLE DELINEATOR
- ⊥ TYPE III BARRICADES WITH STEADY BURNING LIGHTS
- ▨ WORK ZONE
- ➔ ARROW BOARD
- ⊥ SIGN

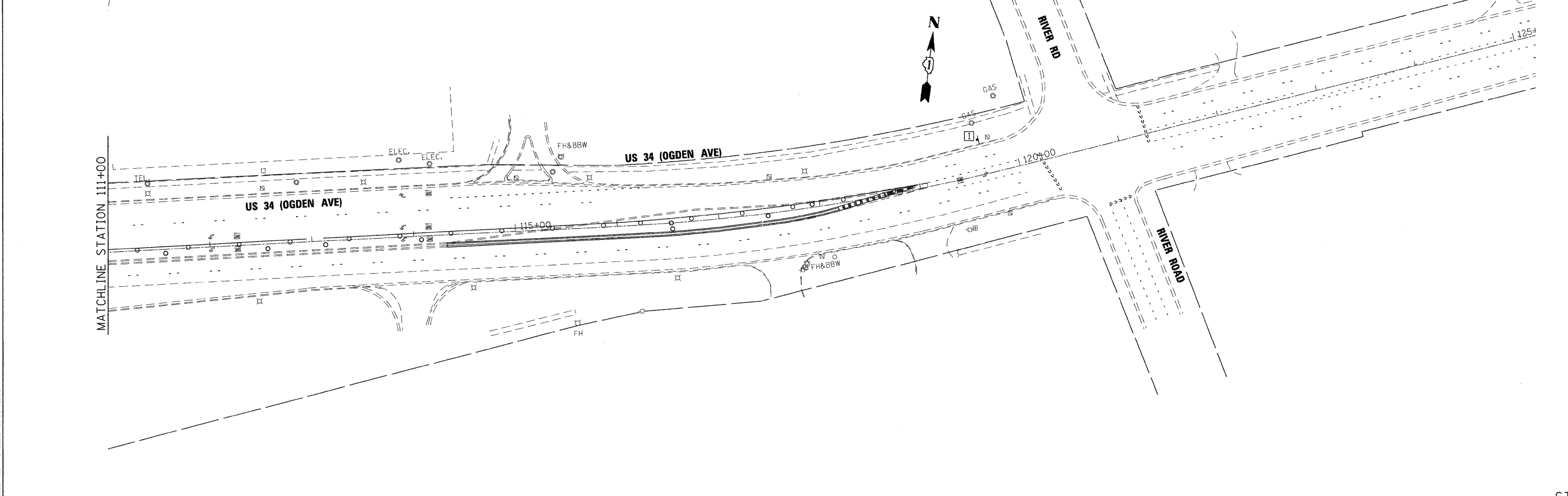

P:\2009\ME0906_Ver-Yer-PH1\CADD\W022.US34\Sta\11160L22-STG02.dgn
 PLOT SCALE = 50.0000' / 1" IN.
 USER NAME = Millennium Professional Services

200 22ND Street, Suite 216, Lombard, IL 60148
 630.785.0110 voice, 630.839.3566 fax
 www.mps-ill.com
MILLENNIA PROFESSIONAL SERVICES

DESIGNED - CJD	REVISED -
DRAWN - CJD	REVISED -
CHECKED - TVN	REVISED -
DATE - 5/31/2011	REVISED -

STATE OF ILLINOIS
DEPARTMENT OF TRANSPORTATION

US ROUTE 34
AT NORTH AURORA ROAD / RAYMOND DRIVE

SUGGESTED STAGES OF CONSTRUCTION
AND TRAFFIC CONTROL
STAGE II

F.A.P. RTE. 311	SECTION 652X-N-3	COUNTY DUPAGE	TOTAL SHEETS 34	SHEET NO. 14
FED. ROAD DIST. NO. 1 (ILLINOIS) FED. AID PROJECT			CONTRACT NO. 60L22	

STG-02

P:\2009\ME0906_Ver-Yer-PH1\CADD\W022.US34\Sta\11160L22-STG02.dgn

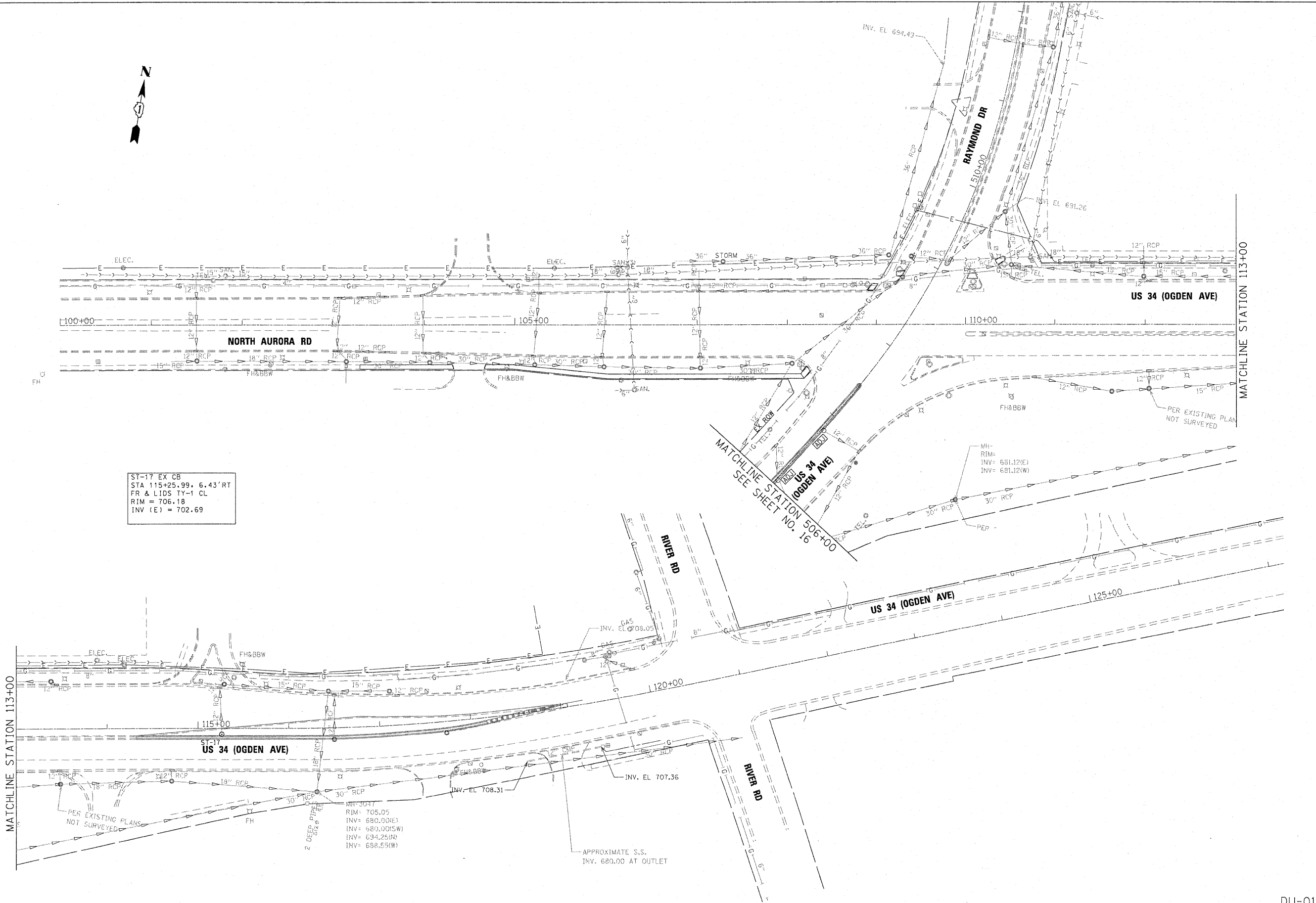

ST-17 EX CB
 STA 115+25.99, 6.43' RT
 FR & LIDS TY-1 CL
 RIM = 706.18
 INV (E) = 702.69

MATCHLINE STATION 113+00

MATCHLINE STATION 113+00

MATCHLINE STATION 113+00

DU-01

FILE NAME = P:\2009\ME09006_Ver_Ver_P\I\CA00\W022.US34\Shs\Di60L22-DU01.dgn
 USER NAME = Millennium Professional Services
 KE 7-18-2011

MILLENNIA PROFESSIONAL SERVICES
 200 22ND Street, Suite 216, Lombard, IL 60148
 630.705.0110 voice, 630.839.2566 fax
 www.mps-ll.com

DESIGNED - CJD	REVISED -
DRAWN - CJD	REVISED -
CHECKED - TVN	REVISED -
DATE - 7/15/2011	REVISED -

**STATE OF ILLINOIS
 DEPARTMENT OF TRANSPORTATION**

**US ROUTE 34
 AT NORTH AURORA ROAD / RAYMOND DRIVE**

DRAINAGE AND UTILITIES PLAN

SCALE: 1"=50' SHEET NO. 1 OF 2 SHEETS STA. 100+00 TO STA. 121+00

F.A.P. RTE. 311	SECTION 652X-N-3	COUNTY DUPAGE	TOTAL SHEETS 34	SHEET NO. 15
CONTRACT NO. 60L22				
FED. ROAD DIST. NO. 1 ILLINOIS FED. AID PROJECT				

P:\2009\ME09006_Ver_Ver_P\I\CA00\W022.US34\Shs\Di60L22-DU01.dgn

PLAN	DATE
SURVEYED	BY
PLOTTED	DATE
REVISIONS	
RT OF MAY CHECKED	
CAD FILE NAME	
NO.	

PROFILE	DATE
REVISIONS	BY
GRADES CHECKED	DATE
STRUCTURE NOTATIONS OK'D	
NOTE BOOK	
FILE NAME	
PLLOT SCALE	
USER NAME	

ST-01 STA 501+94.6, 14.4' RT 6' MH TY A W/FR & LIDS T1 CL RIM = 685.80 INV (NE) = 682.30	ST-07 STA 502+68.48, 21.67' LT 2' CB TYPE C W/FR & LIDS TY-1, OL RIM = 686.89 INV (W) = 682.67	ST-13 STA 503+48.01, 24.10' RT 2' CB TY C W/FR & LIDS T1, OL RIM = 686.3 INV (S) = 681.31
ST-02 STA 503+40.0, 10.25' RT 6' MH TYPE A W/FR & LIDS T1 CL RIM = 687.19 INV = 681.70 (N,S)	ST-08 STA 502+48.57, 20.91' LT 2' CB TYPE C W/FR & LIDS T1, OL RIM = 686.76 INV (W) = 682.67	ST-14 STA 503+58.07, 25.31' RT 2' CB TYPE C W/FR & LIDS T1, OL RIM = 688.79 INV (W) = 681.51
ST-03 STA 504+06.6, 28.1' RT 4' CB TY D FR & LIDS TY-1 CL RIM = 689.31 INV = 684.71 (E)	ST-09 STA 504+06.5, 32.65' RT 2' CB TY C W/ TY-24 F&G RIM = 689.25 INV = 684.73 (E,W)	ST-15 STA 504+29.88, 30.71' RT 4' CB TY D W/FR & LIDS TY-1 CL RIM = 690.95 INV (SW) = 681.65 INV (E) = 681.55
ST-04 STA 505+75.21, 73.29' RT EX MH TO BE ADJUSTED RIM = INV (SW) = 681.65	ST-10 STA 504+05.6, 37.34' RT 2' INLET TYPE A W/ TY-9 F&G RIM = 692.02 INV = 684.75	ST-16 EX CB STA 505+32.48, 3.93' RT FR & LIDS TY-1 CL RIM = 694.68 INV (E) = 689.58
ST-05 STA 505+22.12, 34.34' RT 4' CB TY A W/FR & LIDS T1, CL RIM = 694.38 INV (S) = 689.18	ST-11 STA 503+38.0, 24.12' RT 4' CB TY A W/FR & LIDS T1, OL RIM = 684.91 INV = 681.11 (E)	
ST-06 STA 505+19.19, 43.92' RT 2' CB TYPE C W/ TY-24 F&G RIM = 694.06 INV (W) = 689.21	ST-12 STA 503+37.8, 28.59' RT 2' INLET TY A W/ TY-9 F&G RIM = 687.68 INV (SW) = 681.15	

P-01 146 LF - 29" X 45" ERCP CL A, TY-1, BF=44.1 CY	P-2 94 LF - 36" RCP CL A, TY-1, BF=67.5 CY	P-3 158 LF - 36" RCP CL A, TY-1, BF=104.5 CY	P-4 11 LF - 15" RCP CL A, TY-1, BF=2.8 CY	P-5 11 LF - 15" RCP CL A, TY-1, BF=2.9 CY	P-6 5 LF - 15" RCP CL A, TY-1, BF=0.6 CY
P-7 10 LF - 15" RCP CL A, TY-1, BF=1.7 CY	P-8 10 LF - 15" RCP CL A, TY-1, BF=3.8 CY	P-9 5 LF - 12" RCP CL A, TY-1, BF=1.0 CY	P-10 5 LF - 12" RCP CL A, TY-1, BF=0.8 CY	P-11 11 LF - 12" RCP CL A, TY-1, BF=2.2 CY	

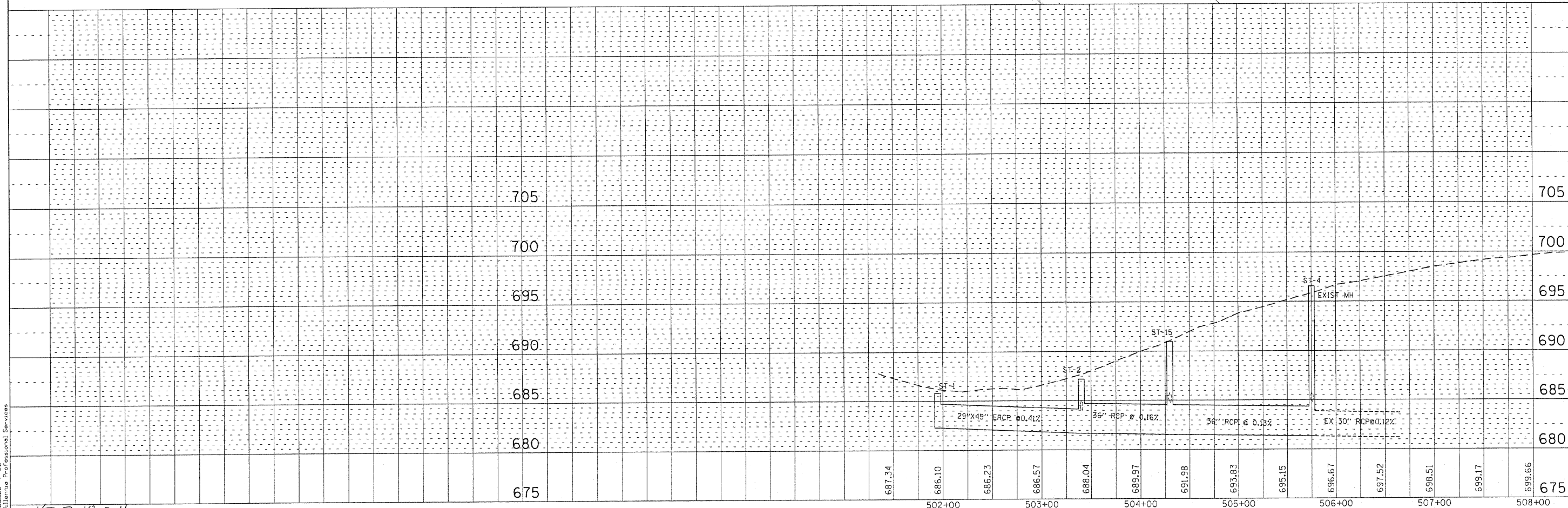
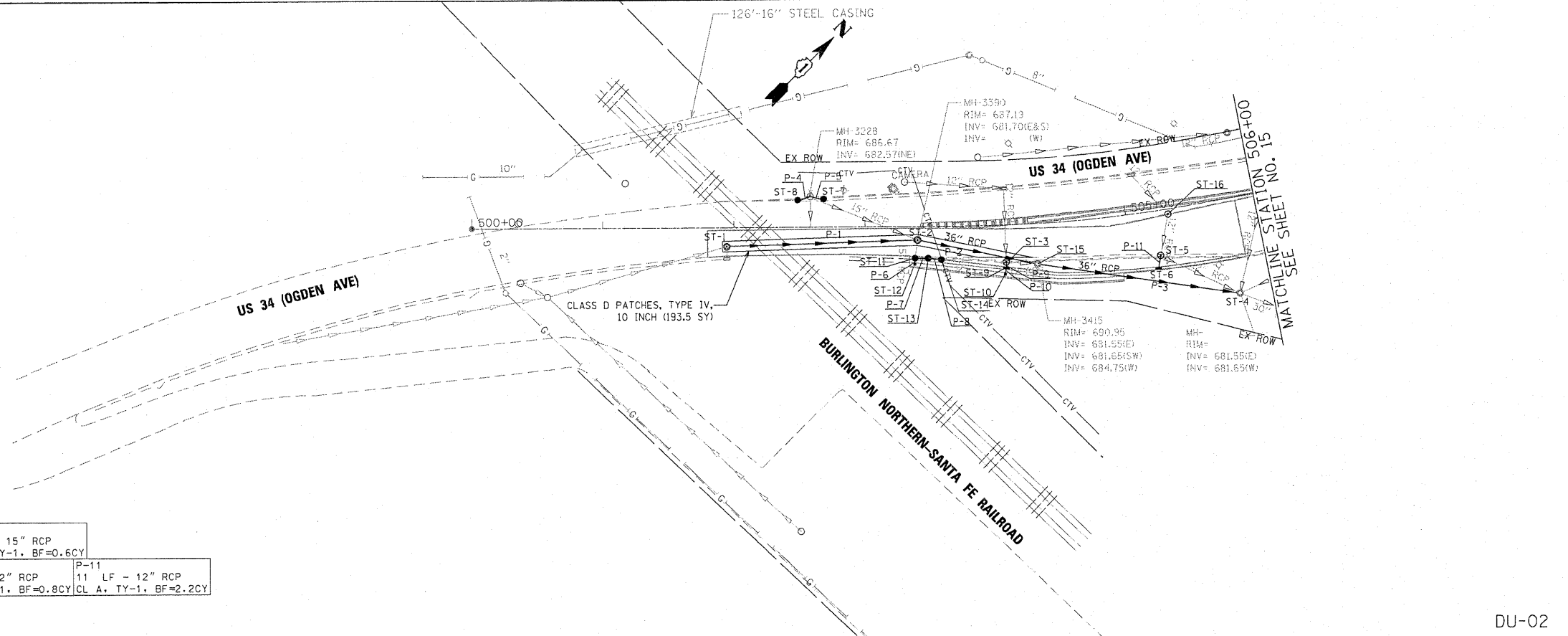

FILE NAME : P:\2009\ME24006_Ver\Proj\CADD\W022_US34_Shts\DIGR\24-DU02.dwg
 PLOT SCALE : 1"=50'
 USER NAME : Millennium Professional Services

KE 7-18-2011

MILLENNIA PROFESSIONAL SERVICES
 300 22ND Street, Suite 216, Lombard, IL 60148
 630.765.0118 voice, 630.839.2566 fax
 WWW.MPS-IL.COM

DESIGNED - TVN	REVISED -
DRAWN - TVN	REVISED -
CHECKED - RPD	REVISED -
DATE - 7/15/2011	REVISED -

STATE OF ILLINOIS
DEPARTMENT OF TRANSPORTATION

US ROUTE 34
AT NORTH AURORA ROAD /RAYMOND DRIVE
DRAINAGE AND UTILITY PLAN

SCALE: 1"=50' SHEET NO. 2 OF 2 SHEETS STA. 500+00 TO STA. 506+00

F.A.P. RTE. 311	SECTION 652X-N-3	COUNTY DUPAGE	TOTAL SHEETS 34	SHEET NO. 16
CONTRACT NO. 60L22			FED. ROAD DIST. NO. 1 ILLINOIS FED. AID PROJECT	

DU-02

MATCHLINE STATION 506+00
 SEE SHEET NO. 15

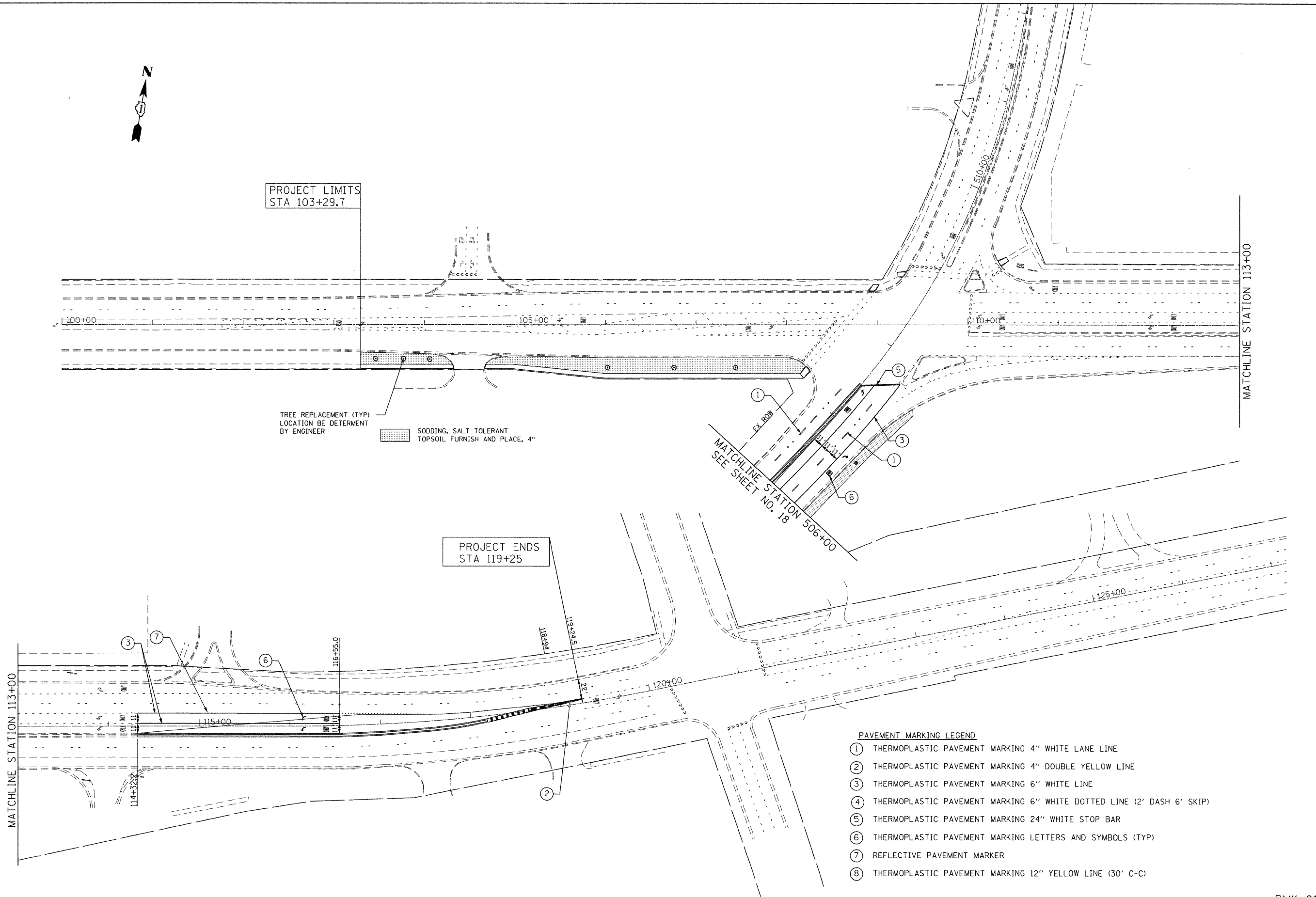

PROJECT LIMITS
STA 103+29.7

TREE REPLACEMENT (TYP)
LOCATION BE DETERMINED
BY ENGINEER

SODDING, SALT TOLERANT
TOPSOIL FURNISH AND PLACE, 4"

PROJECT ENDS
STA 119+25

MATCHLINE STATION 506+00
SEE SHEET NO. 18

PAVEMENT MARKING LEGEND

- ① THERMOPLASTIC PAVEMENT MARKING 4" WHITE LANE LINE
- ② THERMOPLASTIC PAVEMENT MARKING 4" DOUBLE YELLOW LINE
- ③ THERMOPLASTIC PAVEMENT MARKING 6" WHITE LINE
- ④ THERMOPLASTIC PAVEMENT MARKING 6" WHITE DOTTED LINE (2' DASH 6' SKIP)
- ⑤ THERMOPLASTIC PAVEMENT MARKING 24" WHITE STOP BAR
- ⑥ THERMOPLASTIC PAVEMENT MARKING LETTERS AND SYMBOLS (TYP)
- ⑦ REFLECTIVE PAVEMENT MARKER
- ⑧ THERMOPLASTIC PAVEMENT MARKING 12" YELLOW LINE (30' C-C)

FILE NAME = P:\2009\ME09006_Ver-Vor-PRIT\CADD\W022_US34\Shets\160L22-PMK01.dgn
 PLOT SCALE = 1/8" = 1'-0"
 USER NAME = Millennium Professional Services



200 22ND Street, Suite 216, Lombard, IL 60148
 630.795.8118 voice, 630.839.2566 fax
 www.mps-ill.com

MILLENNIA PROFESSIONAL SERVICES

DESIGNED - CJD	REVISED -
DRAWN - CJD	REVISED -
CHECKED - TVN	REVISED -
DATE - 5/31/2011	REVISED -

**STATE OF ILLINOIS
DEPARTMENT OF TRANSPORTATION**

**US ROUTE 34
AT NORTH AURORA ROAD /RAYMOND DRIVE**

PAVEMENT MARKING PLAN

SCALE: 1"=50' SHEET NO. 1 OF 2 SHEETS STA. 103+29.7 TO STA. 119+25

F.A.P. RTE.	SECTION	COUNTY	TOTAL SHEETS	SHEET NO.
311	652X-N-3		34	17
FED. ROAD DIST. NO. 1 (ILLINOIS) FED. AID PROJECT			CONTRACT NO. 60L22	

PMK-01

P:\2009\ME09006_Ver-Vor-PRIT\CADD\W022_US34\Shets\160L22-PMK01.dgn

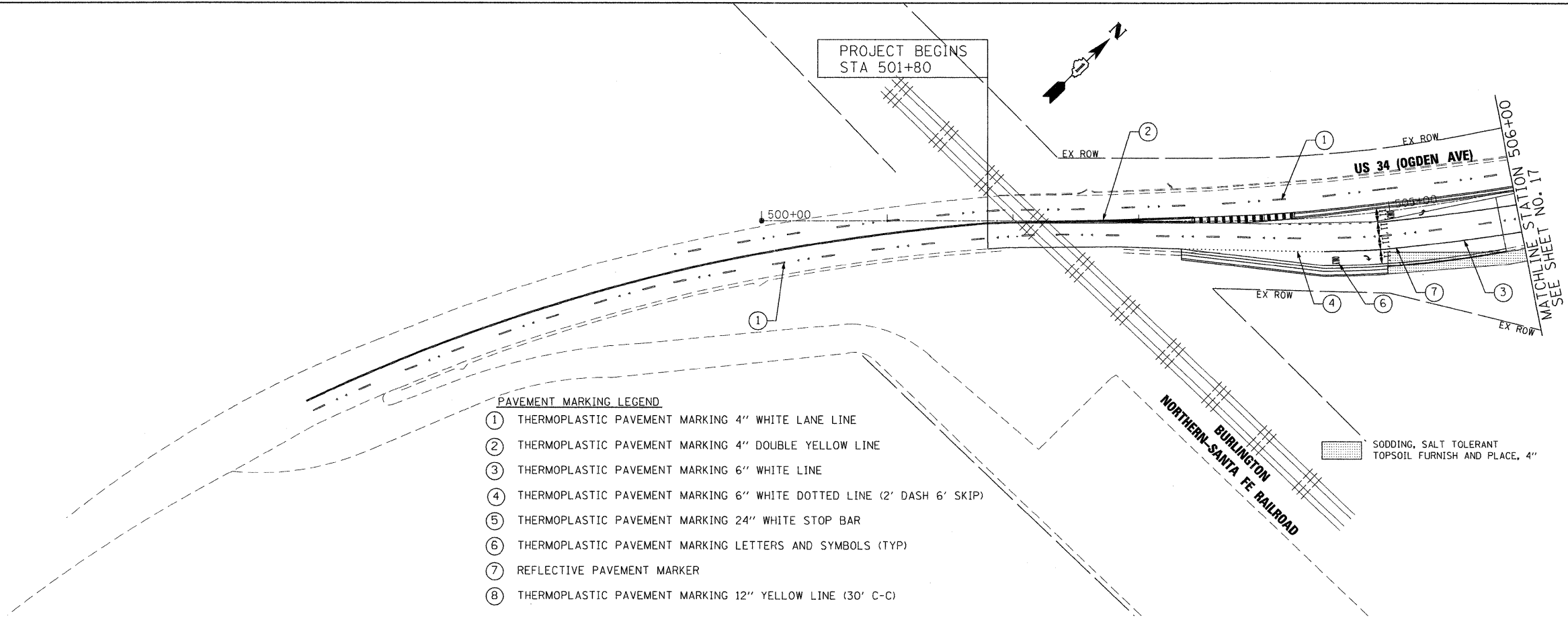

- PAVEMENT MARKING LEGEND**
- ① THERMOPLASTIC PAVEMENT MARKING 4" WHITE LANE LINE
 - ② THERMOPLASTIC PAVEMENT MARKING 4" DOUBLE YELLOW LINE
 - ③ THERMOPLASTIC PAVEMENT MARKING 6" WHITE LINE
 - ④ THERMOPLASTIC PAVEMENT MARKING 6" WHITE DOTTED LINE (2' DASH 6' SKIP)
 - ⑤ THERMOPLASTIC PAVEMENT MARKING 24" WHITE STOP BAR
 - ⑥ THERMOPLASTIC PAVEMENT MARKING LETTERS AND SYMBOLS (TYP)
 - ⑦ REFLECTIVE PAVEMENT MARKER
 - ⑧ THERMOPLASTIC PAVEMENT MARKING 12" YELLOW LINE (30' C-C)

SODDING, SALT TOLERANT
TOPSOIL FURNISH AND PLACE, 4"

FILE NAME = P:\2009\ME09086-Ver-Yor-PH11\CADD\W022-US34\Shets\0160L22-PMK02.dgn
 PLOT SCALE = 5/8/2009 / JN
 USER NAME = Millennia Professional Services



200 22ND Street, Suite 216, Lombard, IL 60148
 630.705.0110 voice, 630.839.2566 fax
 www.mps-il.com
MILLENNIA PROFESSIONAL SERVICES

DESIGNED - CJD	REVISED -
DRAWN - CJD	REVISED -
CHECKED - TVN	REVISED -
DATE - 5/31/2011	REVISED -

**STATE OF ILLINOIS
DEPARTMENT OF TRANSPORTATION**

**US ROUTE 34
AT NORTH AURORA ROAD / RAYMOND DRIVE**

PAVEMENT MARKING PLAN

F.A.P. RTE. 311	SECTION 652X-N-3	COUNTY	TOTAL SHEETS 34	SHEET NO. 18
CONTRACT NO. 60L22				

PMK-02

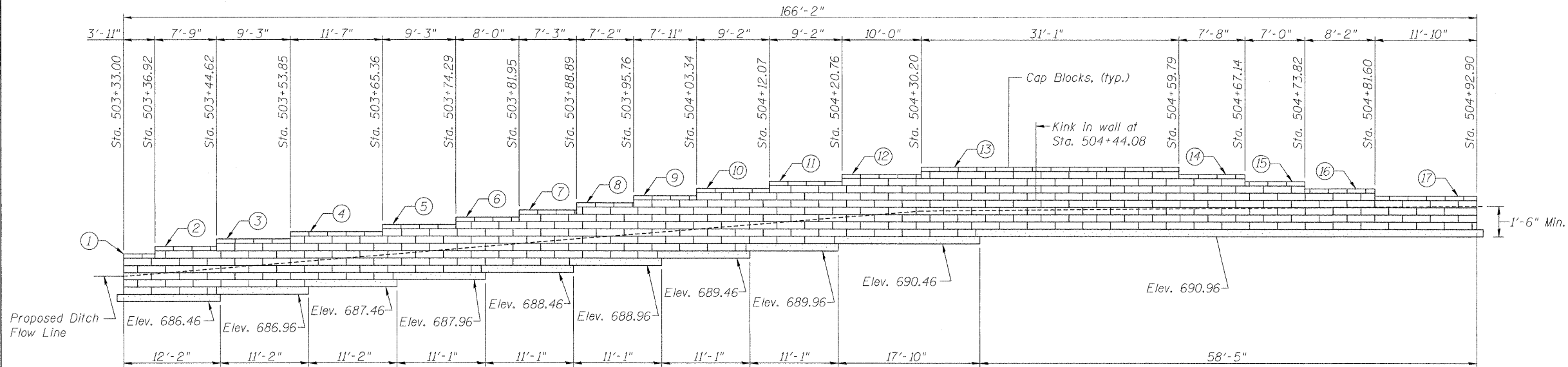

Geometry is based on 6" block heights.
Geometry shall be adjusted per block dimensions used.

WALL ELEVATION
(Dimensions along back face of ditch)

EDGE OF PAVEMENT STATIONS & OFFSETS

Station	*Offset (Rt.)
503+34.00	22.45'
503+40.00	23.15'
503+50.00	24.33'
503+60.00	25.50'
503+70.00	26.68'
503+80.00	27.96'
503+90.00	29.34'
504+00.00	30.82'
504+10.00	32.40'
504+20.00	34.08'
504+30.00	35.86'
504+40.00	37.74'
504+50.00	39.05'
504+60.00	39.69'
504+70.00	40.30'
504+80.00	40.87'
504+93.25	41.57'

* Offsets refer to the distance from @ South leg of US 34 to the edge of proposed pavement, measured at right angles or radially from Sta. 503+34.00 to Sta. 504+93.25. See Sheet 2 of 2 for typical cross-section.

THEORETICAL TOP OF CAP BLOCK ELEVATIONS

①	Elev. 689.47
②	Elev. 689.97
③	Elev. 690.47
④	Elev. 690.97
⑤	Elev. 691.47
⑥	Elev. 691.97
⑦	Elev. 692.47
⑧	Elev. 692.97
⑨	Elev. 693.47
⑩	Elev. 693.97
⑪	Elev. 694.47
⑫	Elev. 694.97
⑬	Elev. 695.47
⑭	Elev. 694.97
⑮	Elev. 694.47
⑯	Elev. 693.97
⑰	Elev. 693.47

CURVE DATA

PI Sta. = 504+71.67
 $\Delta = 11^\circ 08' 02''$ (LT)
 $D = 5^\circ 19' 17''$
 $R = 1,076.73'$
 $T = 104.95'$
 $L = 209.23'$
 $E = 5.10'$
 P.C. Sta. = 503+66.72
 P.T. Sta. = 505+75.95

TOTAL BILL OF MATERIAL

ITEM	UNIT	TOTAL
Segmental Concrete Block Wall	Sq. Ft.	575
Concrete Barrier, Single Face, 42 Inch Height	Foot	166
Paved Ditch (Special)	Foot	166

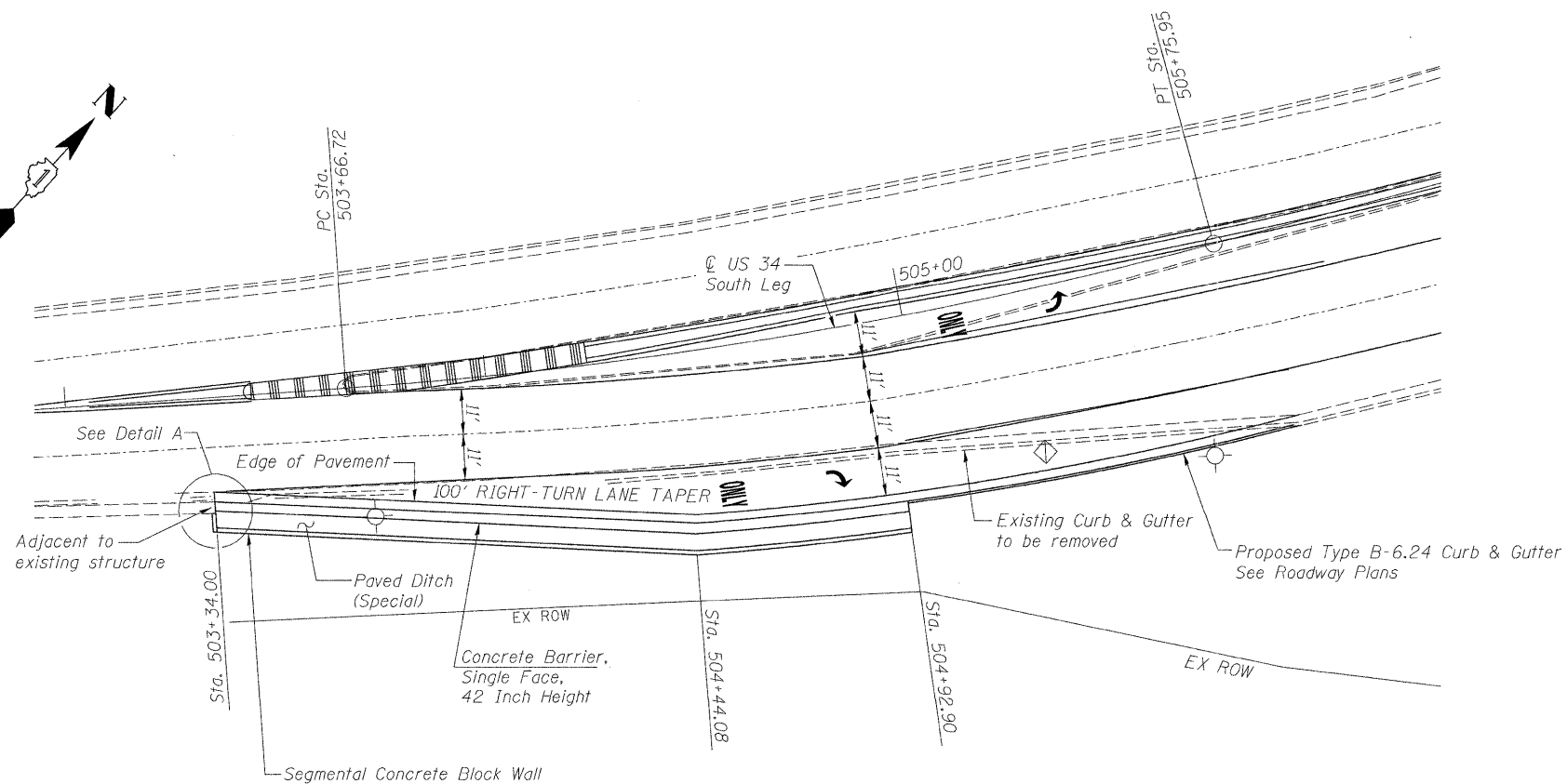
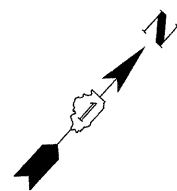

PLAN

Note:
Stations are measured to back face of paved ditch.
See Sheet 2 of 2 for Detail A.

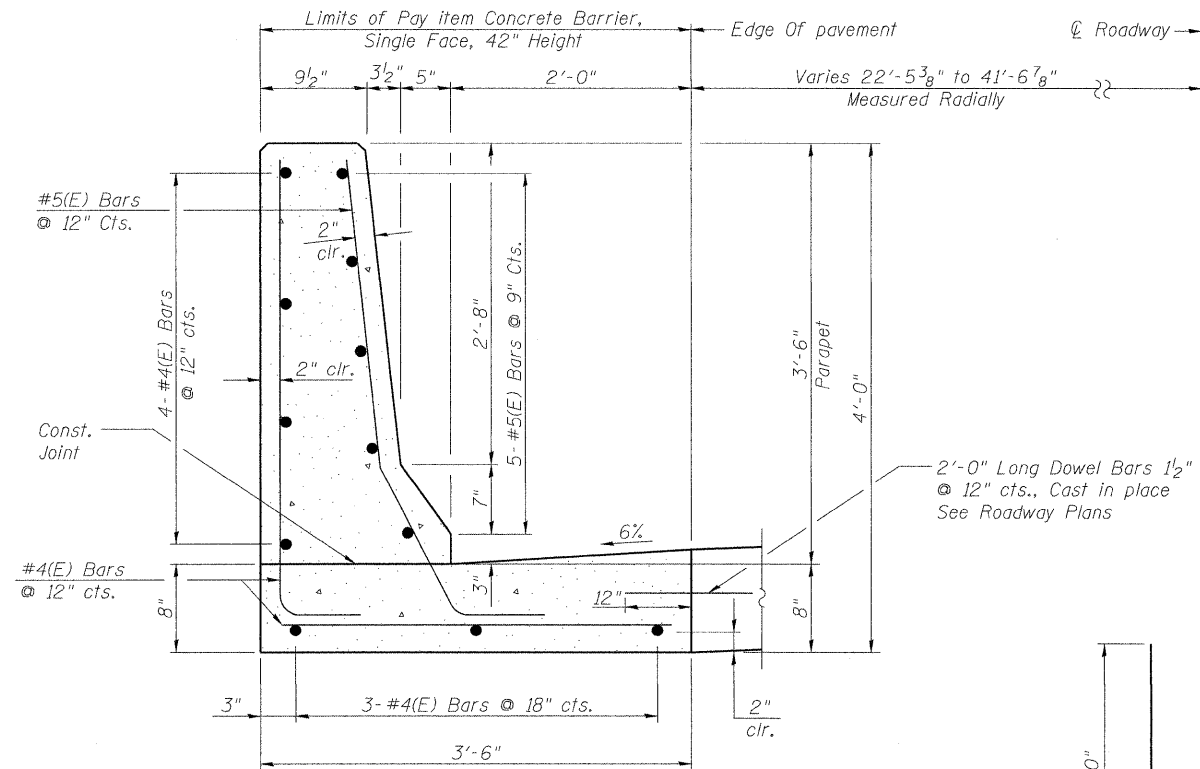

CONCRETE BARRIER, SINGLE FACE, 42 INCH HEIGHT
 (Horizontal dimensions at right angles to barrier unless noted otherwise)

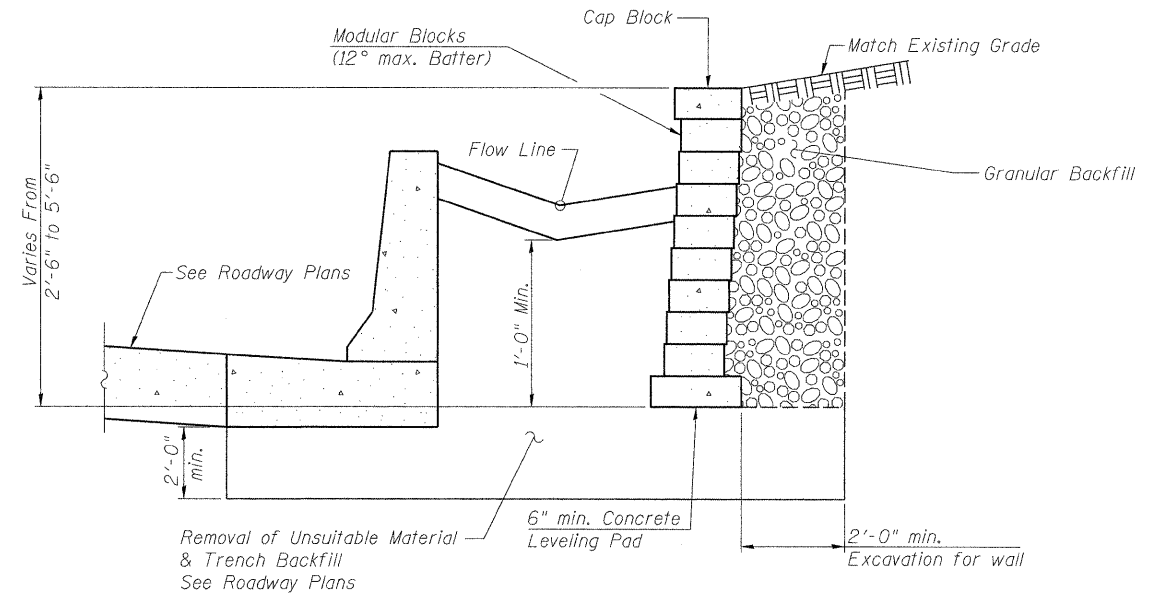

TYPICAL SECTION - UNREINFORCED RETAINING WALL

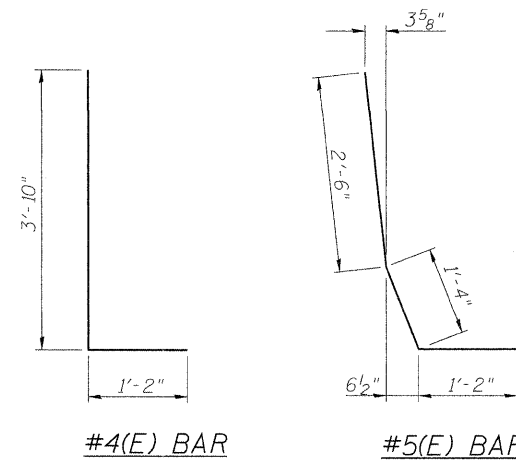

Notes:

- Block Retaining Walls shall be constructed to manufacturer's specifications and to the approval of the Engineer.
- The Schematic representation shown in the drawings is arbitrary. Appropriate adjustments shall be made to suit the manufacturer's product size.
- Excavation, granular backfill, concrete blocks, concrete leveling pad shown in plans and other accessories shall be included in the pay item "Segmental Concrete Block Wall"
- All cast in place concrete shall have a minimum compressive strength f'_c of 3,500 psi.
- Reinforcement bars shall conform to the requirements of ASTM A 706 Gr 60. See Special Provisions.
- Reinforcement bars designated (E) shall be epoxy coated.
- Reinforcement bars and support slab concrete to be provided per above detail shall be included in the contract cost per foot for "Concrete Barrier, Single Face, 42 Inch Height".
- Welded wire fabric shall be included in "Paved Ditch (Special)".
- Contractor shall submit construction drawings for parapet showing joints and reinforcement details for Engineer's approval.
- Ditch shape to match that of Type 9 inlet grate.

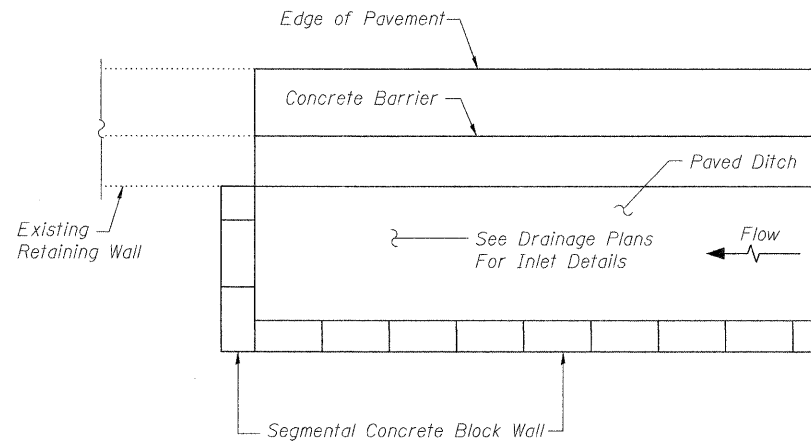

DETAIL A

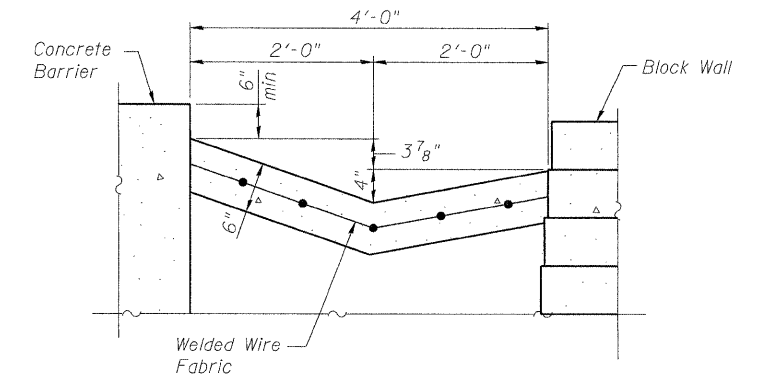

PAVED DITCH DETAIL

USER NAME =	DESIGNED - TBP	REVISED -
FILE NAME =	CHECKED - KHH	REVISED -
PLOT SCALE =	DRAWN - AJF	REVISED -
PLOT DATE =	CHECKED - KHH	REVISED -

F.A.P. RTE. 311	SECTION 652X-N-3	COUNTY	TOTAL SHEETS 34	SHEET NO. 20
CONTRACT NO. 60L22			FED. ROAD DIST. NO. 1 [ILLINOIS] FED. AID PROJECT	

SCHEDULE OF QUANTITIES

ITEM	UNIT	QUANTITY
CONDUIT IN TRENCH, 2" DIA., GALVANIZED STEEL	FOOT	240
HANDHOLE	EACH	1
REBUILD EXISTING HANDHOLE	EACH	1
TRENCH AND BACKFILL FOR ELECTRICAL WORK	FOOT	240
ELECTRIC CABLE IN CONDUIT, SIGNAL, NO. 14 2C	FOOT	475
PEDESTRIAN SIGNAL HEAD, LED, 1-FACE, BRACKET MOUNTED WITH COUNTDOWN TIMER	EACH	4
PEDESTRIAN SIGNAL HEAD, LED, 2-FACE, BRACKET MOUNTED WITH COUNTDOWN TIMER	EACH	1
DETECTOR LOOP REPLACEMENT	FOOT	90
PEDESTRIAN PUSH-BUTTON	EACH	6
REMOVE EXISTING HANDHOLE	EACH	1

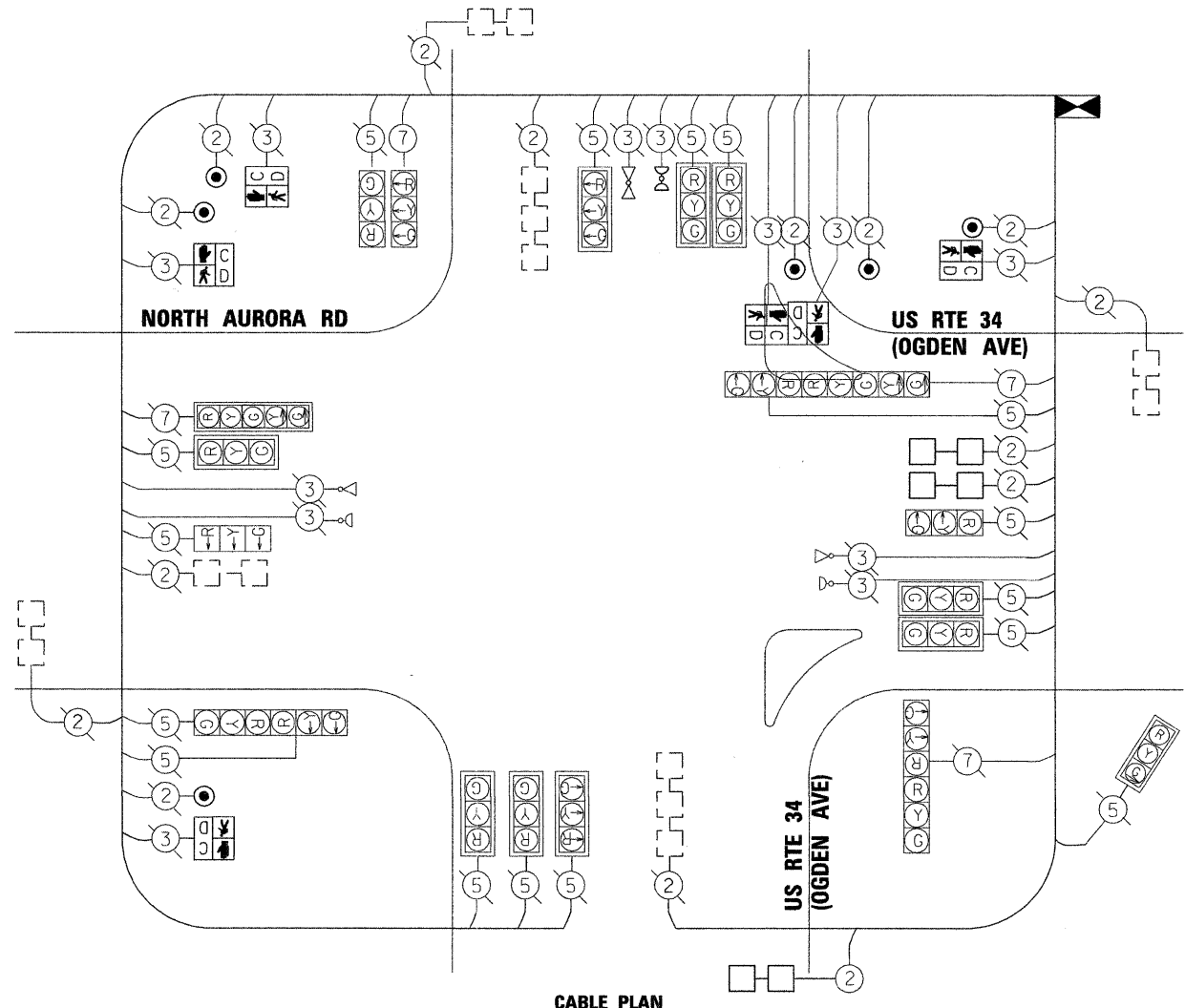

CABLE PLAN

CABLE PLAN LEGEND

EXISTING	PROPOSED	DESCRIPTION
		8" (200mm) TRAFFIC SIGNAL SECTION
		12" (300mm) TRAFFIC SIGNAL SECTION
		12" (300mm) PEDESTRIAN SIGNAL SECTION
		PEDESTRIAN SIGNAL HEAD, INTERNATIONAL SYMBOL, WITH COUNTDOWN TIMER
		CONTROLLER CABINET
		SERVICE INSTALLATION
		VEHICLE DETECTOR, INDUCTION LOOP
		MAGNETIC DETECTOR
		EMERGENCY VEHICLE LIGHT DETECTOR
		CONFIRMATION BEACON
		PUSHBUTTON DETECTOR
		DENOTES NUMBER OF CONDUCTORS. ALL CABLE NO. 14 EXCEPT AS INDICATED. ALL LOOP DETECTOR CABLE TO BE SHIELDED.
		SIGNAL FACE WITH BACKPLATE "P" INDICATES PROGRAMMED HEAD.
		RAILROAD CONTROL CABINET
		ILLUMINATED SIGN, FIBER OPTIC "NO LEFT TURN"
		ILLUMINATED SIGN, FIBER OPTIC "NO RIGHT TURN"
		GROUND ROD AT HANDHOLE, DOUBLE HANDHOLE, OR CONTROLLER
		GROUND ROD AT POST OR MAST ARM POLE
		GROUND ROD AT ELECTRIC SERVICE INSTALLATION
		GROUND CABLE IN CONDUIT NO. 6 SOLID COPPER (GREEN)
		FIBER OPTIC CABLE IN CONDUIT NO. 62.5/125 2-MM12F & SM12F
		UNINTERRUPTIBLE POWER SUPPLY (UPS)
		PERFORMED LOOP DETECTION



EMERGENCY VEHICLE PREEMPTION SEQUENCE

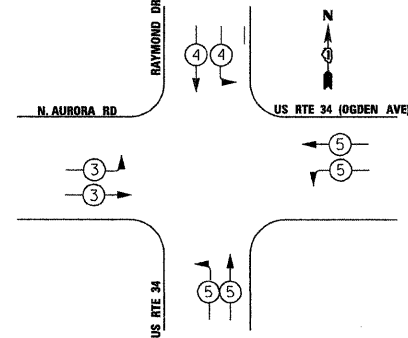

PROPOSED EMERGENCY VEHICLE PREEMPTORS

EMERGENCY VEHICLE PREEMPTOR	3	4	5	6
MOVEMENT				

PROPOSED CONTROLLER SEQUENCE

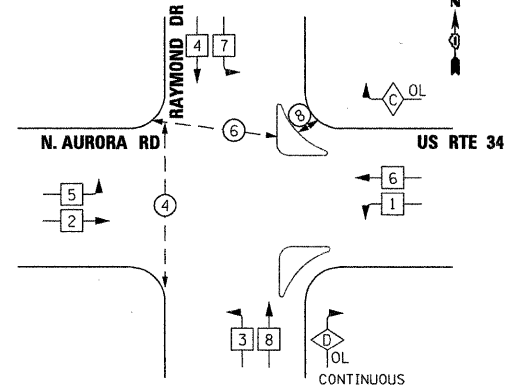

PHASE DESIGNATION DIAGRAM

LEGEND

	SINGLE ENTRY PHASE
	DUAL ENTRY PHASE
	OVERLAP
	PEDESTRIAN PHASE
NUMBER REFERS TO ASSOCIATED PHASE	
OVERLAP LETTER	PERMISSIVE PHASE + PROTECTED PHASE
C	= 6 + 7
D	= NONE + ALL PHASE

I.D.O.T TRAFFIC SIGNAL INSTALLATION ELECTRICAL SERVICE REQUIREMENTS

TYPE	NO. OF LAMPS	WATTAGE INCAND.	L.E.D.	OPERATION	TOTAL WATTAGE
SIGNAL (RED)		135	17	0.50	
(YELLOW)		135	25	0.25	
(GREEN)		135	15	0.25	
ARROW		135	12	0.10	
PED. SIGNAL	6	90	25	1.00	150
CONTROLLER		100	100	1.00	
ILLUM. SIGN		84		0.05	
HOT RIGHT		135	12	1.00	
VIDEO VEH. SENSOR		15	15	1.00	
FLASHER				0.50	
TOTAL					150

ILLINOIS DEPARTMENT OF TRANSPORTATION
 DIVISION OF HIGHWAY/DISTRICT 1
 201 CENTER CT/SCHAUMBURG, IL 60196-1096
 ENERGY SUPPLY - CONTACT:
 PHONE: 630-691-4379
 COMPANY: COMMONWEALTH EDISON

FOUNDATION (DEPTH)	(FEET) (m)	CABLE SLACK	(FEET) (m)	VERTICAL	(FEET) (m)
TYPE A - POST	4 , (1.2)	HANDHOLE	6.5 , (2.0)	ALL FOUNDATION	1.0 , (0.3)
D - CONTROLLER	4 , (1.2)	DOUBLE HANDHOLE	13 , (4.0)	MAST ARM (1.) POLE	20'+L-2 = (6m+L-0.6m)=
E - M. ARM POLE	()	SIGNAL POST	2 , (0.6)	BRACKET MOUNTED	13 , (4.0)
24" (600mm)	10 , (3.0)	CONTROLLER CAB.	1 , (0.3)	PED. PUSHBUTTON	4 , (1.2)
30" (600mm)	15 , (4.5)	FIBER OPTIC	13 , (4.0)	ELECTRIC SERVICE	13.5 , (4.1)
36"	15 , (4.5)	ELECTRIC SERVICE	1 , (0.3)	SERVICE TO GROUND	13 , (4.1)
42"	15 , (4.5)	GROUND CABLE	1 , (0.3)	POST MOUNTED	6 , (1.8)

DESIGNED - CJD	REVISED -
DRAWN - CJD	REVISED -
CHECKED - TVN	REVISED -
DATE - 5/31/2011	REVISED -

STATE OF ILLINOIS DEPARTMENT OF TRANSPORTATION

US ROUTE 34 AT NORTH AURORA ROAD /RAYMOND DRIVE

SCHEDULE OF QUANTITIES, CABLE PLAN, PHASE DESIGNATION DIAGRAM, AND EMERGENCY VEHICLE PREEMPTION SEQUENCE

F.A.P. RTE.	SECTION	COUNTY	TOTAL SHEETS	SHEET NO.
311	652X-N-3	DUPAGE	34	21





CONTRACT NO. 60L22

FILE NAME = P:\2009\ME09006_Ver-Vor_Plan\CADD\W022.US34\Sh1a\0160L22-SHT-TS02.dgn
 PLOT SCALE = 20/80000 / IN.
 USER NAME = Millennium Professional Services

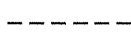
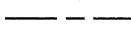

200 22ND Street, Suite 216, Lombard, IL 60148
 630.795.0110 voice, 630.839.2566 fax
 www.mps-il.com
MILLENNIA PROFESSIONAL SERVICES

LIGHTING LEGEND

-  EXISTING LIGHTING UNIT TO REMAIN IN PLACE
-  EXISTING LIGHTING UNIT TO BE RELOCATED PRIOR TO CONSTRUCTION
-  EXISTING CABLES TO REMAIN IN PLACE
-  PROPOSED UNIT DUCT, SIZE AND TYPE AS SHOWN ON THE PLANS
-  EXISTING STREET LIGHTING CONTROLLER

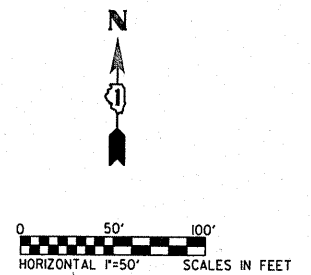
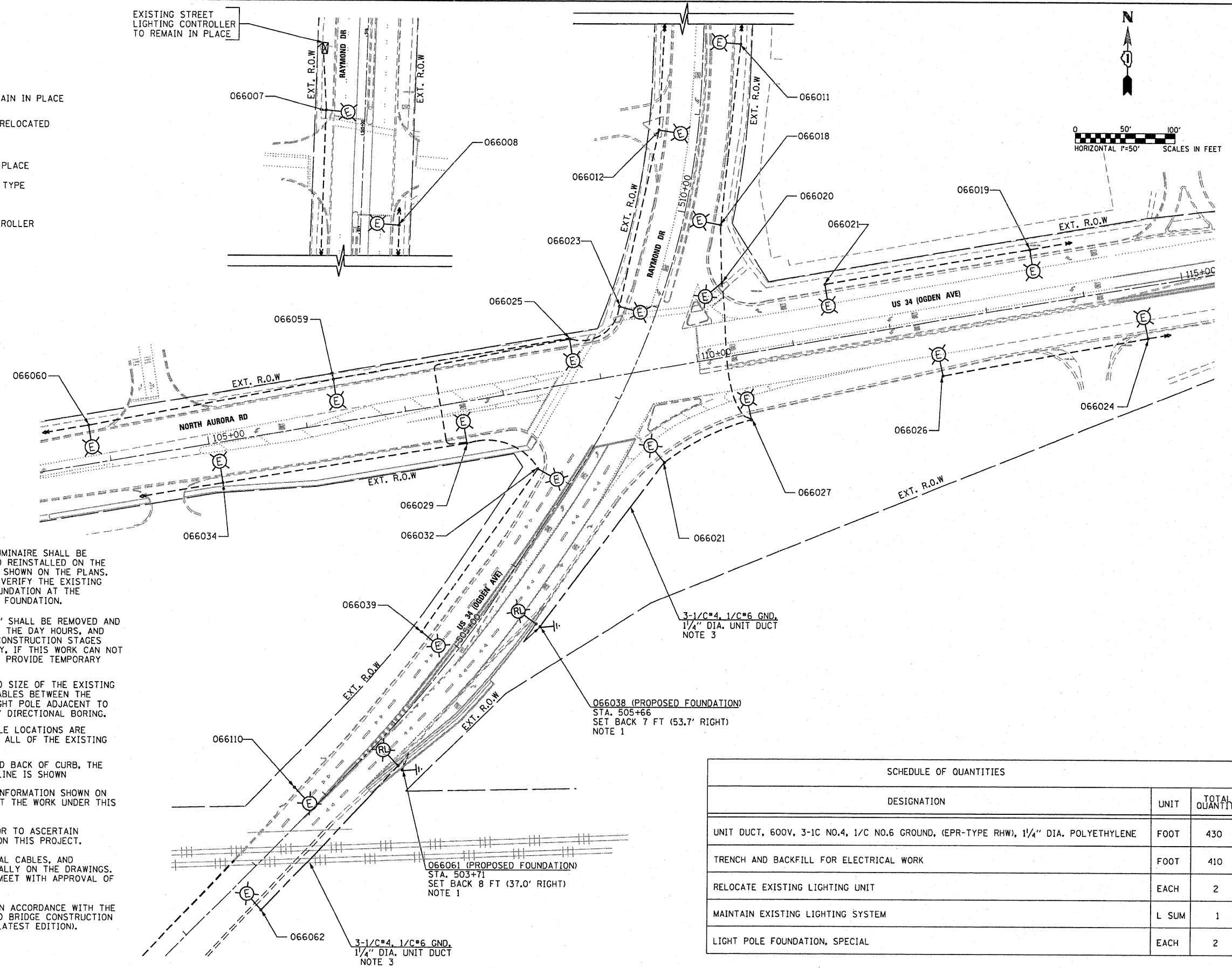

NOTES:

1. THE EXISTING LIGHT POLE, MAST ARM, AND LUMINAIRE SHALL BE REMOVED FROM THE EXISTING FOUNDATION AND REINSTALLED ON THE NEW FOUNDATION AT THE PROPOSED LOCATION SHOWN ON THE PLANS. IT IS THE CONTRACTOR'S RESPONSIBILITY TO VERIFY THE EXISTING FOUNDATION BEFORE CONSTRUCTING A NEW FOUNDATION AT THE PROPOSED LOCATION, TO MATCH THE EXISTING FOUNDATION.
2. ALL EXISTING LIGHT POLES MARKED WITH "RL" SHALL BE REMOVED AND REINSTALLED ON THE NEW FOUNDATION DURING THE DAY HOURS, AND SHALL BE OPERATIONAL BEFORE ALL OF THE CONSTRUCTION STAGES START. THIS WORK SHALL BE DONE IN ONE DAY, IF THIS WORK CAN NOT BE DONE IN ONE DAY, THE CONTRACTOR SHALL PROVIDE TEMPORARY LIGHTING AT THE EFFECTED AREA.
3. THE CONTRACTOR SHALL VERIFY THE TYPE AND SIZE OF THE EXISTING CABLES TO MATCH THEM, AND INSTALL NEW CABLES BETWEEN THE RELOCATED LIGHT POLE AND THE EXISTING LIGHT POLE ADJACENT TO IT. THE UNIT DUCTS SHALL BE INSTALLED BY DIRECTIONAL BORING.
4. ALL OF THE EXISTING LIGHT POLES AND CABLE LOCATIONS ARE APPROXIMATE, THE CONTRACTOR SHALL VERIFY ALL OF THE EXISTING CABLES AND CONNECTIONS IN THE FIELD.
5. SET BACKS ARE MEASURED FROM THE PROPOSED BACK OF CURB, THE OFFSET OF THE FOUNDATIONS FROM THE BASELINE IS SHOWN
6. THE CONTRACTOR SHALL VERIFY ALL OF THE INFORMATION SHOWN ON THE CONTRACT DRAWINGS, WHICH WOULD AFFECT THE WORK UNDER THIS CONTRACT.
7. IT IS THE RESPONSIBILITY OF THE CONTRACTOR TO ASCERTAIN EXISTING FIELD CONDITIONS BEFORE BIDDING ON THIS PROJECT.
8. ALL NEW CONDUITS, UNIT DUCTS, DIRECT BURIAL CABLES, AND APPURTENANCES ARE INDICATED DIAGRAMMATICALLY ON THE DRAWINGS. THE ACTUAL LOCATIONS IN THE FIELD SHALL MEET WITH APPROVAL OF THE ENGINEER.
9. THE ELECTRICAL WORK SHALL BE PERFORMED IN ACCORDANCE WITH THE IDOT STANDARD SPECIFICATIONS FOR ROAD AND BRIDGE CONSTRUCTION AND ASSOCIATED SUPPLEMENTAL CONDITIONS (LATEST EDITION).

3-1/2" C#4, 1/C#6 GND,
1/4" DIA. UNIT DUCT
NOTE 3

066038 (PROPOSED FOUNDATION)
STA. 505+66
SET BACK 7 FT (53.7' RIGHT)
NOTE 1

066061 (PROPOSED FOUNDATION)
STA. 503+71
SET BACK 8 FT (37.0' RIGHT)
NOTE 1

3-1/2" C#4, 1/C#6 GND,
1/4" DIA. UNIT DUCT
NOTE 3

SCHEDULE OF QUANTITIES		
DESIGNATION	UNIT	TOTAL QUANTITY
UNIT DUCT, 600V, 3-1C NO.4, 1/C NO.6 GROUND, (EPR-TYPE RHW), 1/4" DIA. POLYETHYLENE	FOOT	430
TRENCH AND BACKFILL FOR ELECTRICAL WORK	FOOT	410
RELOCATE EXISTING LIGHTING UNIT	EACH	2
MAINTAIN EXISTING LIGHTING SYSTEM	L SUM	1
LIGHT POLE FOUNDATION, SPECIAL	EACH	2

GO GANDHI AND ASSOCIATES, INC.
ENGINEERS AND PLANNERS
6035 N. NORTHWEST HIGHWAY
SUITE 306
CHICAGO, ILLINOIS 60631 TEL. (773) 774-5910

FILE NAME =	USER NAME = .GAL	DESIGNED - PKG	REVISED -
#FILE#		DRAWN - MAA, SHM	REVISED -
		CHECKED - PKG	REVISED -
		DATE - 5/27/2011	REVISED -

**STATE OF ILLINOIS
DEPARTMENT OF TRANSPORTATION**

PROPOSED LIGHTING PLAN

SCALE: 1" = 50' SHEET NO. OF SHEETS STA. TO STA.

F.A.P. RTE. 311	SECTION 652X-N-3	COUNTY DUPAGE	TOTAL SHEETS 34	SHEET NO. 22
FINAL			CONTRACT NO. 60L22	
FED. ROAD DIST. NO. 1 ILLINOIS FED. AID PROJECT				

LIGHT POLE FOUNDATION DEPTH TABLE
40 FT. (12.192 m) TO 47.5 FT. (14.478 m) MOUNTING HEIGHT

SOIL CONDITIONS	DESIGN DEPTH "D" OF FOUNDATION	
	SINGLE ARM POLE	TWIN ARM POLE
SOFT CLAY O _u = 0.375 TON/SQ. FT.	13'-0" (3.96 m)	15'-0" (4.57 m)
MEDIUM CLAY O _u = 0.75 TON/SQ.FT	9'-6" (2.93 m)	10'-9" (3.23 m)
STIFF CLAY O _u = 1.50 TON/SQ. FT.	7'-0" (2.13 m)	8'-0" (2.44 m)
LOOSE SAND φ = 34°	9'-0" (2.74 m)	10'-0" (3.05 m)
MEDIUM SAND φ = 37.5°	8'-3" (2.52 m)	9'-0" (2.74 m)
DENSE SAND φ = 40°	7'-9" (2.36 m)	9'-0" (2.74 m)

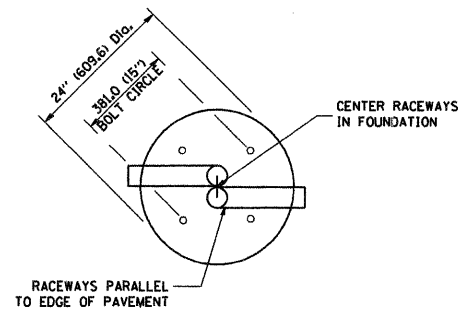

TOP VIEW

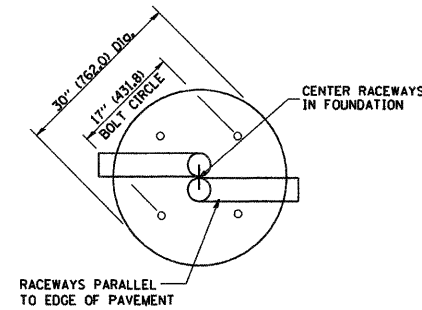

TOP VIEW

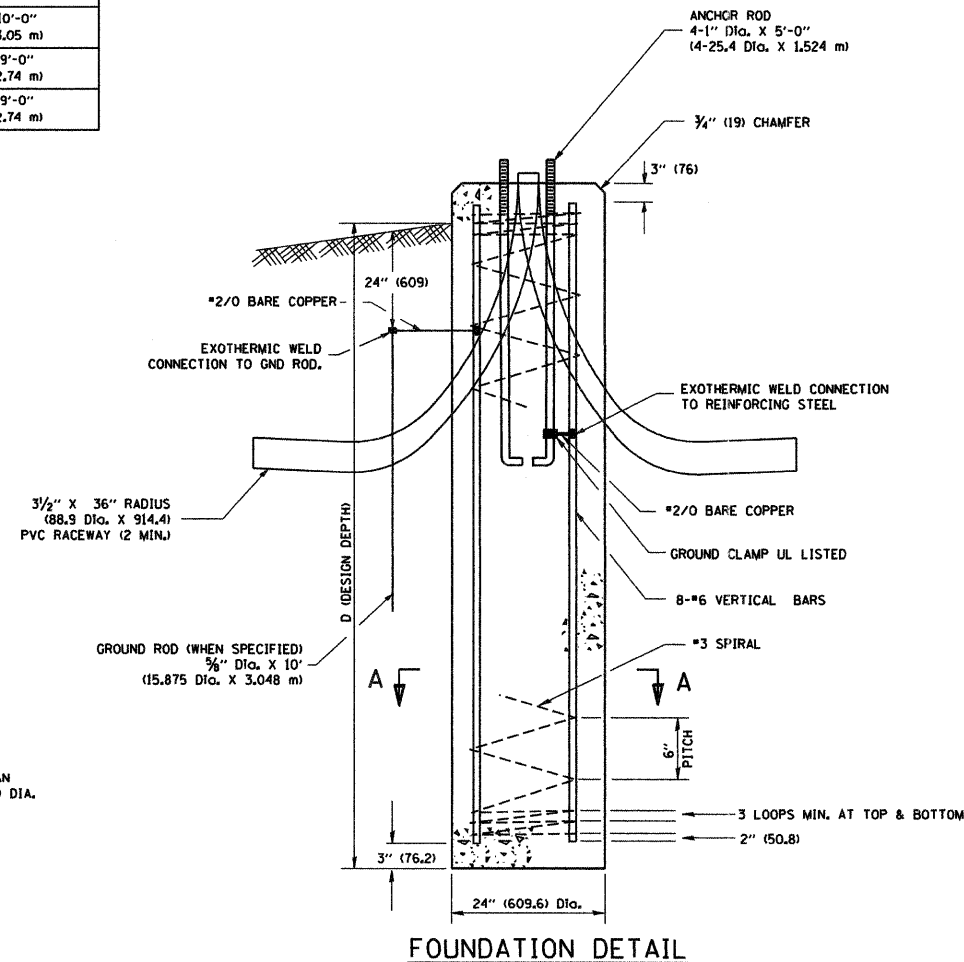

FOUNDATION DETAIL

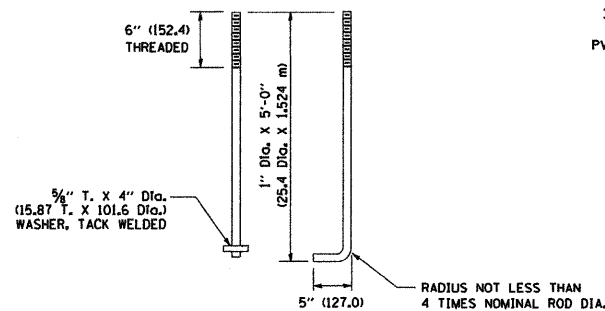

ANCHOR ROD DETAIL

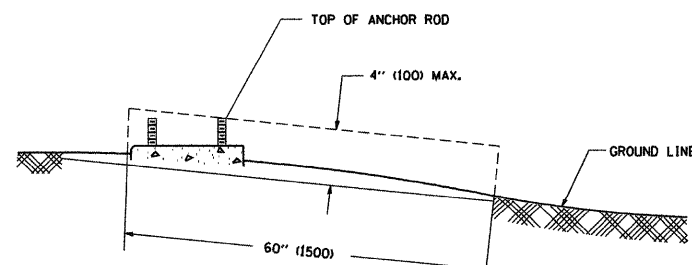

FOUNDATION EXTENSION DETAIL

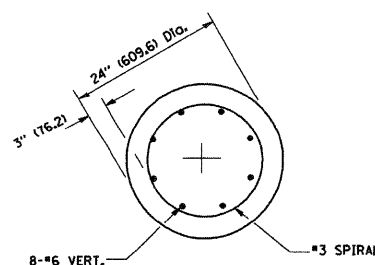

SECTION A-A

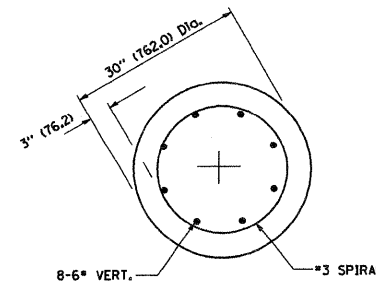

SECTION A-A

NOTES

- ALL DIMENSIONS ARE IN INCHES (MILLIMETERS) UNLESS OTHERWISE SHOWN.
- THE ANCHOR RODS AND RACEWAYS SHALL BE PROPERLY SECURED IN PLACE BEFORE THE CONCRETE IS PLACED.
- THE FOUNDATION SHALL NOT PROTRUDE MORE THAN 100MM (4 IN.) ABOVE THE FINISHED GRADE WITHIN A 60 IN. (1.5 m) CHORD ACROSS THE FOUNDATION, WITH ANCHOR RODS INCLUDED, IN ACCORDANCE WITH AASHTO GUIDELINES. IF THE FOUNDATION HEIGHT, INCLUDING ANCHOR RODS, EXTENDS BEYOND THESE SPECIFIED LIMITS, THE FOUNDATION SHALL BE REPLACED AT THE CONTRACTOR'S EXPENSE. SEE FOUNDATION EXTENSION DETAIL.
- THE HOLE FOR THE FOUNDATION SHALL BE MADE BY DRILLING WITH AN AUGER, OF THE SAME DIAMETER AS THE FOUNDATION. IF SOIL CONDITIONS REQUIRE THE USE OF A LINER TO FORM THE HOLE, THE LINER SHALL BE WITHDRAWN AS THE CONCRETE IS DEPOSITED.
- THE TOP OF THE FOUNDATION SHALL BE CONSTRUCTED LEVEL. A LINER OR FORM SHALL BE USED TO PRODUCE A UNIFORM SMOOTH SIDE TO THE TOP OF THE FOUNDATION. FOUNDATION TOP SHALL BE CHAMFERED 3/4-IN. (20 mm).
- THE CONCRETE SHALL BE CLASS S1. CONCRETE SHALL CURE ACCORDING TO ARTICLE 1020.13 BEFORE LIGHT POLES ARE INSTALLED.
- THE ANCHOR ROD SHALL BE A HOOK ROD TYPE. COLD BENDING OF THE ANCHOR ROD WILL NOT BE ALLOWED. THE RADIUS OF THE HOOK BEND SHALL NOT BE LESS THAN 4 TIMES THE NOMINAL DIAMETER OF THE ANCHOR ROD. A TACK WELDED ANCHOR ROD MAY BE SUBSTITUTED WITH THE APPROVAL OF THE ENGINEER.
- THE ANCHOR RODS SHALL BE ACCORDING TO ASTM F1554 GRADE 725 (GRADE 105). NUTS SHALL BE HEXAGON NUTS ACCORDING TO ASTM A 194 2H OR ASTM A 563 DH, AND WASHERS SHALL BE ACCORDING TO ASTM F 436.
- ANCHOR RODS, NUTS AND WASHERS SHALL BE COMPLETELY GALVANIZED BY EITHER THE HOT-DIPPED PROCESS CONFORMING WITH AASHTO M 232, THE MECHANICAL PLATING METHOD CONFORMING TO AASHTO M 298, CLASS 50 WITH A MAXIMUM COATING THICKNESS OF 150 UM(6 MILS) OR THE ELECTROLYTIC PROCESS ACCORDING TO ASTM F 1136.
- THE ANCHOR RODS SHALL BE THREADED A MINIMUM OF 6 INCHES (150 mm) WITH A MINIMUM OF 3 INCHES (75 mm) OF THREADED ANCHOR ROD EMBEDDED IN THE FOUNDATION.
- ANCHOR RODS SHALL PROJECT 2 3/4" (69.9 mm) ABOVE THE TOP OF THE FOUNDATION. IF BREAKAWAY COUPLINGS ARE SPECIFIED, THE CONTRACTOR SHALL CAREFULLY COORDINATE THE ANCHOR ROD PROJECTION WITH THE INSTALLATION REQUIREMENTS OF THE BREAKAWAY COUPLINGS.
- THE CONTRACTOR SHALL USE A #3 SPIRAL AT 6" (152.4 mm) PITCH OR MAY SUBSTITUTE #3 TIES AT 12" (304.8 mm) O.C. WITH THE APPROVAL OF THE ENGINEER.
- THE CABLE TRENCHES AND FOUNDATION SHALL BE BACK FILLED AND COMPACTED AS SPECIFIED BEFORE THE LIGHT POLE IS ERECTED.
- THE RACEWAYS SHALL PROJECT 1" (25.4 mm) ABOVE THE TOP OF THE FOUNDATION.

THIS FOUNDATION DETAIL IS FOR INFORMATION ONLY. IT IS THE CONTRACTOR'S RESPONSIBILITY TO VERIFY THE EXISTING FOUNDATION AND BOLT CIRCLE, AND CONSTRUCT NEW FOUNDATION AND BOLT CIRCLE TO MATCH THE EXISTING

FILE NAME = W:\distatd\22x34\be301.dgn	USER NAME = gaglianobt	DESIGNED -	REVISED - 04-22-02	STATE OF ILLINOIS DEPARTMENT OF TRANSPORTATION	LIGHT POLE FOUNDATION			F.A.P. RTE. 311	SECTION 652X-N-3	COUNTY DUPAGE	TOTAL SHEETS 34	SHEET NO. 23
	PLOT SCALE = 50.0000' / IN.	DRAWN -	REVISED -		40' (12.192 m) TO 47 1/2' (14.478 m) M.H. 15" (381 mm) BOLT CIRCLE			BE-301		CONTRACT NO. 60L22		
	PLOT DATE = 1/4/2008	CHECKED -	REVISED -		SCALE: NONE	SHEET NO. 1 OF 1 SHEETS	STA. TO STA.	FED. ROAD DIST. NO. 1 ILLINOIS FED. AID PROJECT				
		DATE -	REVISED -									

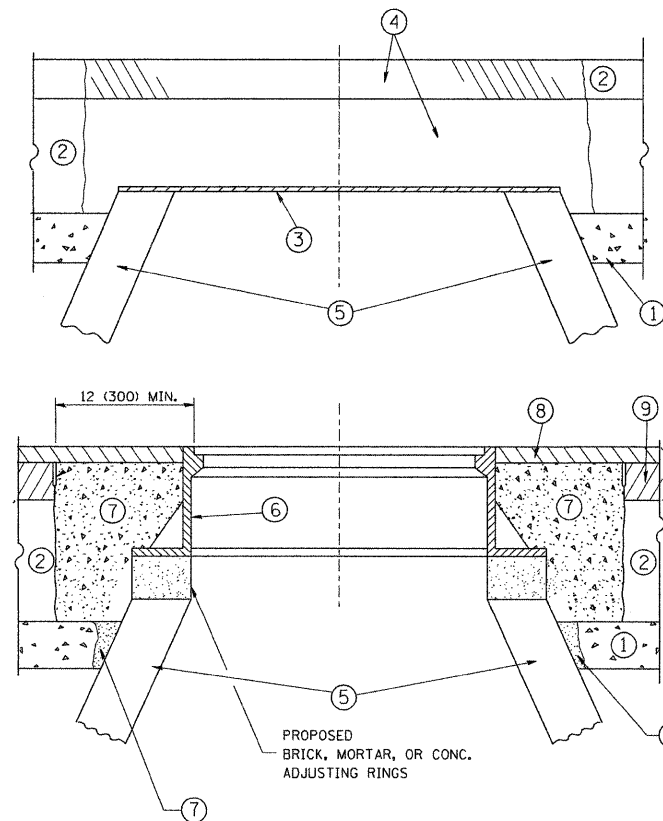

CONSTRUCTION PROCEDURES

STAGE 1 (BEFORE PAVEMENT MILLING)

- A) REMOVE A MINIMUM OF 12 (300) OF THE PAVEMENT FROM AROUND THE STRUCTURE.
- B) REMOVE THE EXISTING FRAME AND LID FROM THE STRUCTURE.
- C) COVER THE STRUCTURE OPENING WITH A 36 (900) DIAMETER METAL PLATE.
- D) BACKFILL WITH CRUSHED STONE AND A MINIMUM 1/2 (40) THICK HMA SURFACE MIX APPROVED BY THE ENGINEER.

STAGE 2 (AFTER PAVEMENT MILLING)

- A) REMOVE THE HMA SURFACE MIX AND CRUSHED STONE.
- B) INSTALL THE FRAME AND LID; ADJUST THE FRAME TO ITS FINAL SURFACE ELEVATION.
- C) THE SURROUNDING SPACE SHALL BE FILLED WITH CLASS PP* CONCRETE EXISTING BASE COURSE OR THE BINDER COURSE.

* THE CLASS OF PP CONCRETE WILL BE AS DIRECTED BY THE ENGINEER.

THE PROCEDURE EXPLAINED ABOVE SHALL CONFORM TO THE APPLICABLE PORTIONS OF SECTIONS 353, 406, 602, AND 603 OF THE STANDARD SPECIFICATIONS.

LEGEND

- ① SUB-BASE GRANULAR MATERIAL
- ② EXISTING PAVEMENT
- ③ 36 (900) DIAMETER METAL PLATE
- ④ PROPOSED CRUSHED STONE AND HMA SURFACE MIX
- ⑤ EXISTING STRUCTURE
- ⑥ FRAME AND LID (SEE NOTES)
- ⑦ CLASS PP* CONCRETE
- ⑧ PROPOSED HMA SURFACE COURSE
- ⑨ PROPOSED HMA BINDER COURSE

LOCATION OF STRUCTURES:

THE CONTRACTOR WILL BE REQUIRED TO KEEP A RECORD OF THE LOCATIONS OF THE BURIED STRUCTURES ACCORDING TO THE STATION AND DISTANCE LEFT OR RIGHT OF THE CENTERLINE OF PAVEMENT. UPON COMPLETION OF THE WORK, THE CONTRACTOR WILL DELIVER THE RECORD TO THE ENGINEER.

BASIS OF PAYMENT: THIS WORK WILL BE PAID FOR AT THE CONTRACT UNIT PRICE PER EACH FOR "FRAMES AND LIDS TO BE ADJUSTED, SPECIAL" NEW FRAMES AND LIDS, WHEN SPECIFIED, WILL BE PAID FOR SEPARATELY.

NOTES:

EXISTING BROKEN FRAMES AND LIDS SHALL BE REMOVED AND DISPOSED OF BY THE CONTRACTOR AND SHALL BE REPLACED AS DIRECTED BY THE ENGINEER. REPLACEMENT FRAMES AND LIDS WILL BE PAID FOR IN ACCORDANCE WITH ARTICLE 109.04 OF THE STANDARD SPECIFICATIONS UNLESS A SEPARATE PAY ITEM HAS BEEN PROVIDED.

IF THE EXISTING LIDS ARE OPEN, THE FRAME WILL BE ADJUSTED TO THE ELEVATION OF THE MILLED PAVEMENT SURFACE PRIOR TO THE MILLING OPERATION. THE FRAME WILL NOT BE REMOVED AND COVERED BY THE METAL PLATE.

CITY OF CHICAGO CASTINGS ARE THE PROPERTY OF THE CITY AND THE CONTRACTOR SHALL NOTIFY THE CITY FOR REMOVAL AND DISPOSITION OF THE CASTINGS.

THE METAL PLATE USED TO COVER THE STRUCTURE SHALL REMAIN THE PROPERTY OF THE CONTRACTOR.

WHEN STRUCTURES ARE TO BE ADJUSTED OR RECONSTRUCTED, THE LOWERING AND RAISING OF THE FRAMES AND LIDS WILL NOT BE PAID FOR SEPARATELY BUT WILL BE INCLUDED IN THE COST OF THE CORRESPONDING PAY ITEM.

DETAILS FOR FRAMES AND LIDS ADJUSTMENT WITH MILLING

ALL DIMENSIONS ARE IN INCHES (MILLIMETERS) UNLESS OTHERWISE SHOWN

FILE NAME =	USER NAME = lcyso	DESIGNED - R. SHAH	REVISED - A. ABBAS 03-21-97
ci\pw_work\p\dot\lcyso\d8106315\bd88.dgn		DRAWN -	REVISED - R. WIEDEMAN 05-14-04
	PLOT SCALE = 49.9999 ' / IN.	CHECKED -	REVISED - R. BORO 01-01-07
	PLOT DATE = 2/4/2011	DATE - 10-25-94	REVISED - R. BORO 02-01-11

**STATE OF ILLINOIS
DEPARTMENT OF TRANSPORTATION**

**DETAILS FOR
FRAMES AND LIDS ADJUSTMENT WITH MILLING**

SCALE: NONE SHEET NO. 1 OF 1 SHEETS STA. TO STA.

F.A.P. RTE.	SECTION	COUNTY	TOTAL SHEETS	SHEET NO.
311	652X-N-3	DUPAGE	34	24
BD600-03 (BD-8)			CONTRACT NO. 60L22	
FED. ROAD DIST. NO. 1 ILLINOIS FED. AID PROJECT				

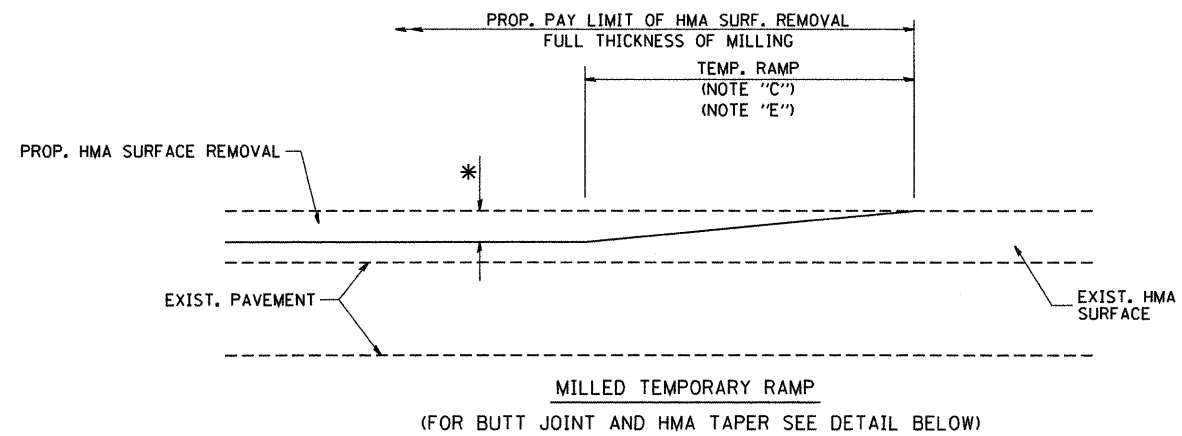

OPTION 1

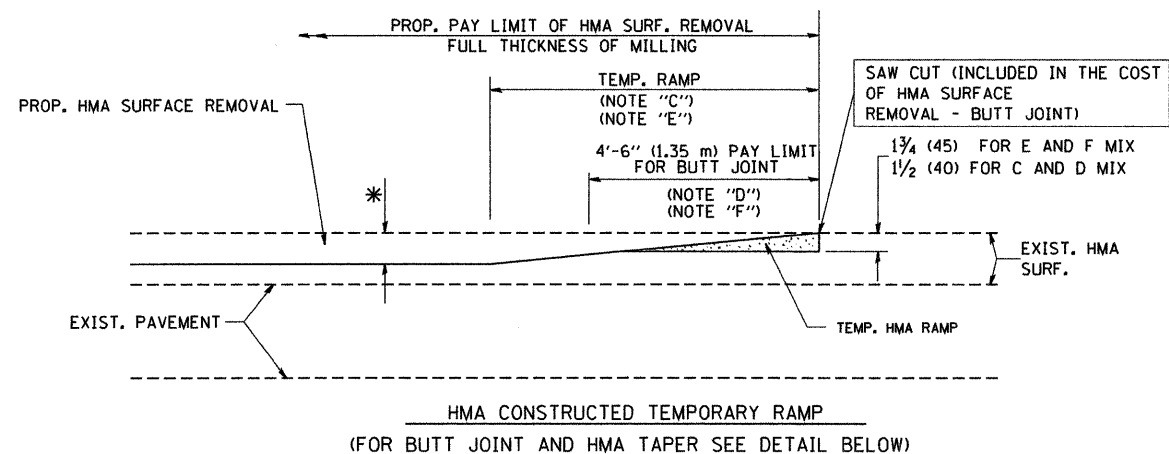

OPTION 2

TYPICAL TEMPORARY RAMP

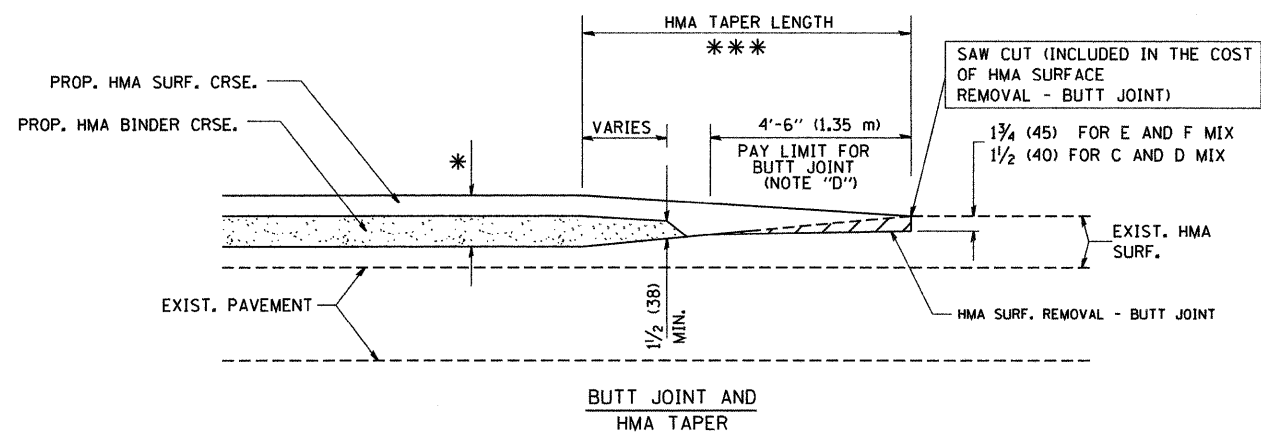

TYPICAL BUTT JOINT AND HMA TAPER FOR MILLING AND RESURFACING

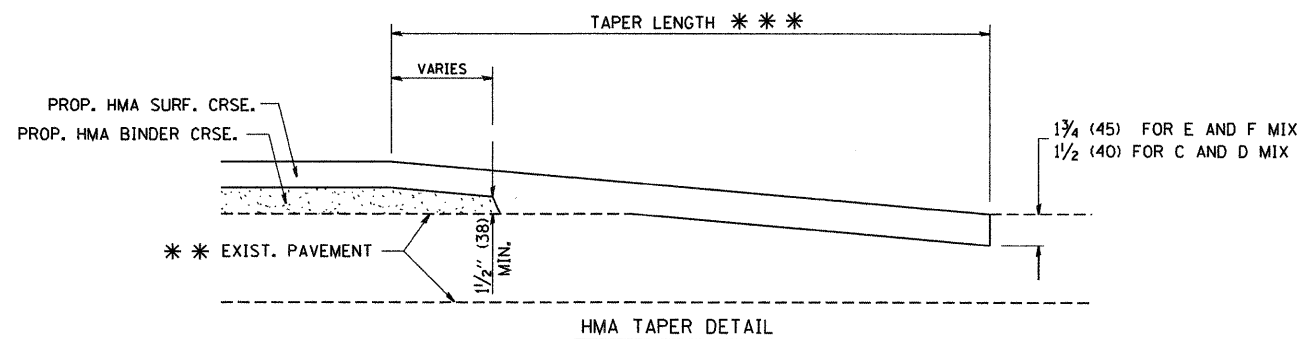
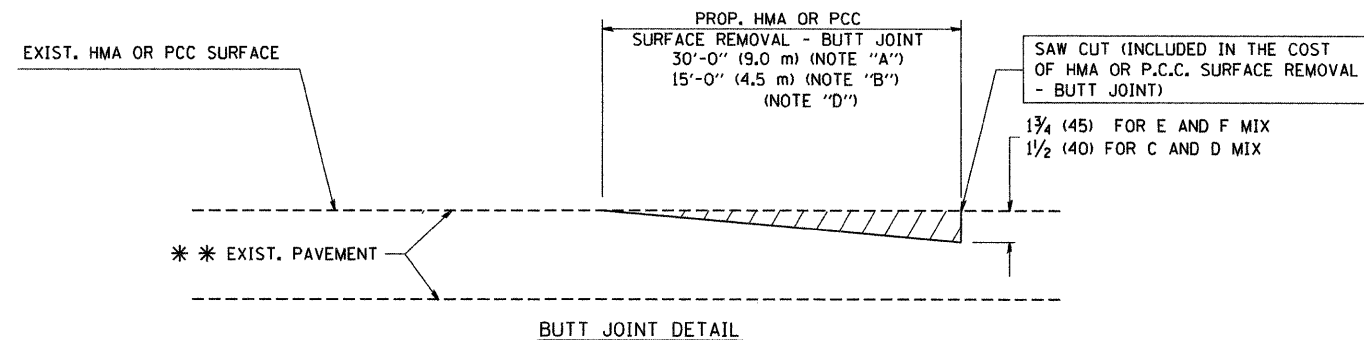

TYPICAL BUTT JOINT AND HMA TAPER FOR RESURFACING ONLY

*** PC CONCRETE, HMA OR HMA RESURFACED PAVEMENT.

NOTES

- A: MAINLINE ROADWAYS AND MAJOR SIDE ROADS.
- B: MINOR SIDE ROADS.
- C: THE TEMP. RAMP SHALL BE CONSTRUCTED IMMEDIATELY UPON REMOVAL OF THE EXISTING HMA SURFACE.
- D: THE BUTT JOINT SHALL BE CONSTRUCTED IMMEDIATELY PRIOR TO PLACING THE PROPOSED HMA COURSES.
- E: TAPER THE TEMP. RAMP AT A RATE OF 3'-0" (900 mm) PER 1 INCH (25 mm) OF MILLING THICKNESS.
- F: INSTALLATION AND REMOVAL OF THE 4'-6" (1.35 m) TEMP. RAMP IS INCLUDED IN COST OF HMA SURFACE REMOVAL - BUTT JOINT
- G: SEE ARTICLE 406.08 AND 406.14 OF THE STANDARD SPECIFICATIONS FOR "HMA AND/OR PCC SURFACE REMOVAL, BUTT JOINT".
- * SEE TYPICAL SECTIONS FOR MILLING THICKNESS.
- *** 20'-0" (6.1 m) PER 1 (25) RESURFACING (NOTE "A")
10'-0" (3.0 m) PER 1 (25) RESURFACING (NOTE "B")

BASIS OF PAYMENT:

THE BUTT JOINT WILL BE PAID FOR AT THE CONTRACT UNIT PRICE PER SQUARE YARD (SQUARE METER) FOR "HOT-MIX ASPHALT SURFACE REMOVAL - BUTT JOINT" OR FOR "PORTLAND CEMENT CONCRETE SURFACE REMOVAL - BUTT JOINT".

ALL DIMENSIONS ARE IN INCHES (MILLIMETERS) UNLESS OTHERWISE SHOWN.

FILE NAME = W:\dstatd\22x34\bd32.dgn

USER NAME = geglionob

DESIGNED - M. DE YONG

REVISED - R. SHAH 10-25-94

PLOT SCALE = 50.0000 "/ IN.

DRAWN -

REVISED - A. ABBAS 03-21-97

PLOT DATE = 1/4/2008

CHECKED -

REVISED - M. GOMEZ 04-06-01

DATE - 06-13-90

REVISED - R. BORO 01-01-07

**STATE OF ILLINOIS
DEPARTMENT OF TRANSPORTATION**

**BUTT JOINT AND
HMA TAPER DETAILS**

F.A.P. RTE.	SECTION	COUNTY	TOTAL SHEETS	SHEET NO.
311	652X-N-3	DUPAGE	34	26
BD400-05 BD32			CONTRACT NO. 60L22	
FED. ROAD DIST. NO. 1 (ILLINOIS) FED. AID PROJECT				

SCALE: NONE SHEET NO. 1 OF 1 SHEETS STA. TO STA.

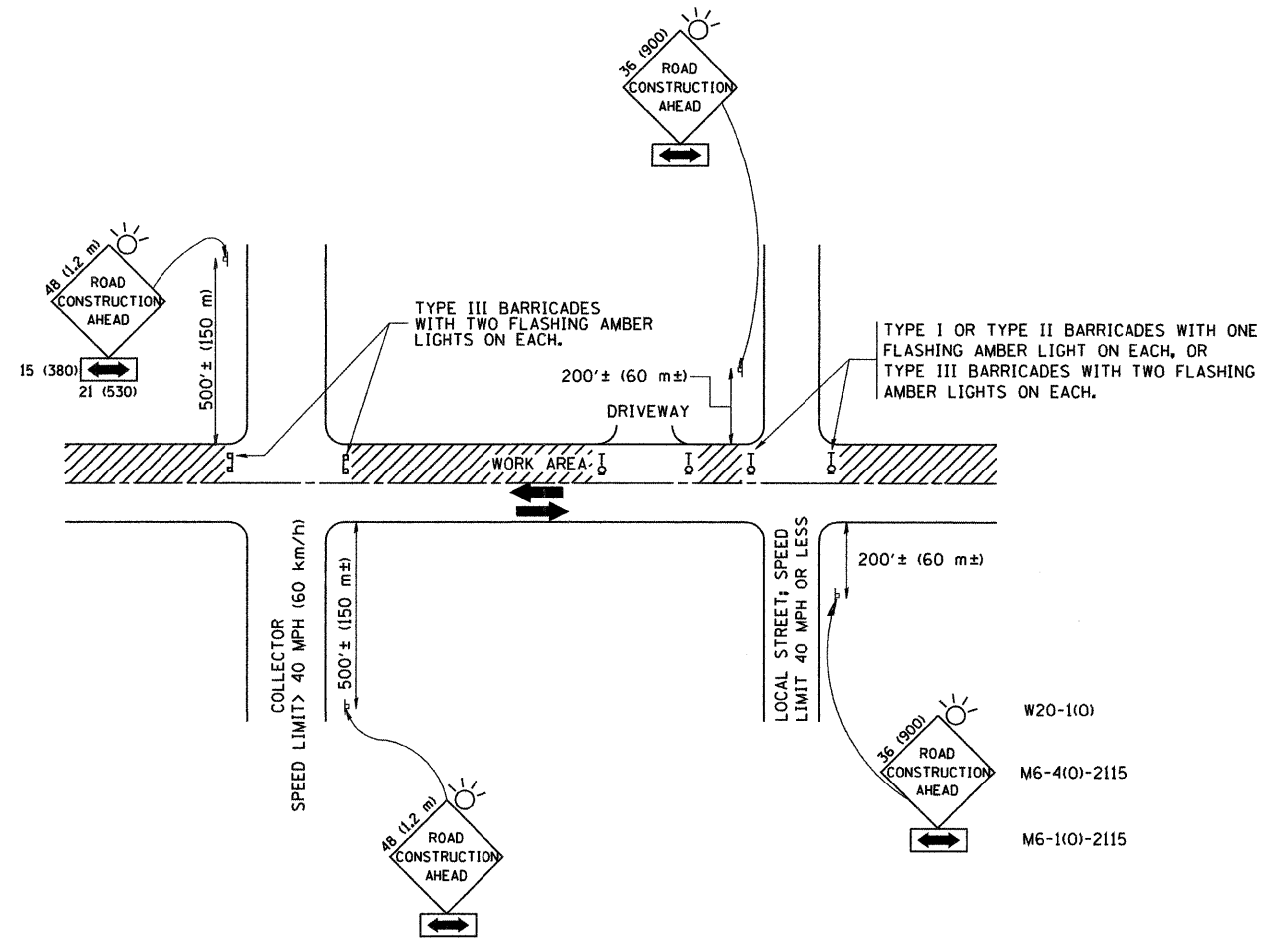

TRAFFIC CONTROL AND PROTECTION FOR SIDE ROADS, INTERSECTIONS, AND DRIVEWAYS

NOTES:

A. FOR NO LANE RESTRICTION ON THE SIDE ROAD OR DRIVEWAYS

1. SIDE ROAD WITH A SPEED LIMIT OF 40 MPH (60 km/h) OR LESS AS SHOWN ON THE DRAWING AND AS DIRECTED BY THE ENGINEER:

a) ONE ROAD CONSTRUCTION AHEAD SIGN 36 x 36 (900x900) WITH A FLASHER AND FLAG MOUNTED ON IT APPROXIMATELY 200' (60 m) IN ADVANCE OF THE MAIN ROUTE.

b) THE CLOSED PORTION OF THE MAIN ROUTE SHALL BE PROTECTED BY BLOCKING WITH TYPE I, TYPE II OR TYPE III BARRICADES, 1/3 OF THE CROSS SECTION OF THE CLOSED PORTION.

2. SIDE ROAD WITH A SPEED LIMIT GREATER THAN 40 MPH (60 km/h) AS SHOWN ON THE DRAWING AND AS DIRECTED BY THE ENGINEER:

a) ONE ROAD CONSTRUCTION AHEAD SIGN 48 x 48 (1.2 m x 1.2 m) WITH A FLASHER MOUNTED ON IT APPROXIMATELY 500' (150 m) IN ADVANCE OF THE MAIN ROUTE.

b) THE CLOSED PORTION OF THE MAIN ROUTE SHALL BE PROTECTED BY BLOCKING WITH TYPE III BARRICADES, 1/2 OF THE CROSS SECTION OF THE CLOSED PORTION.

3. WHEN THE SIDE ROAD LIES BETWEEN THE BEGINNING OF THE MAINLINE SIGNING AND THE WORK ZONE, A SINGLE HEADED ARROW (M6-1) SHALL BE USED IN LIEU OF THE DOUBLE HEADED ARROW (M6-4).

B. FOR A LANE CLOSURE ON A SIDE ROAD OR DRIVEWAY:

USE APPLICABLE PORTIONS OF THE TYPICAL APPLICATION OF TRAFFIC CONTROL DEVICES (STD. 701501, STD. 701606 OR THE APPROPRIATE STANDARD). THE SPACING OF SIGNS AND BARRICADES SHALL BE ADJUSTED FOR FIELD CONDITIONS AS DIRECTED BY THE ENGINEER. THE DIRECTIONAL ARROW SHALL BE COVERED OR REMOVED WHEN NO LONGER CONSISTENT WITH THE SIDE ROAD LANE CLOSURE.

C. ADVANCE WARNING SIGNS ARE TO BE OMITTED ON DRIVEWAY UNLESS OTHERWISE NOTED.

D. THE TRAFFIC CONTROL AND PROTECTION FOR SIDE ROADS, INTERSECTIONS, AND DRIVEWAYS SHALL BE INCIDENTAL TO THE COST OF SPECIFIED TRAFFIC CONTROL STANDARDS OR ITEMS.

All dimensions are in millimeters (inches) unless otherwise shown.

FILE NAME = W:\diststd\22x34\tbl0.dgn	USER NAME = gaglienob	DESIGNED - LHA	REVISED - J. OBERLE 10-18-95
		DRAWN -	REVISED - A. HOUSEH 03-06-96
	PLOT SCALE = 50.000' / IN.	CHECKED -	REVISED - A. HOUSEH 10-15-96
	PLOT DATE = 1/4/2008	DATE - 06-89	REVISED - T. RAMMACHER 01-06-00

STATE OF ILLINOIS
DEPARTMENT OF TRANSPORTATION

TRAFFIC CONTROL AND PROTECTION FOR
SIDE ROADS, INTERSECTIONS, AND DRIVEWAYS

SCALE: NONE SHEET NO. 1 OF 1 SHEETS STA. TO STA.

F.A.R. RTE.	SECTION	COUNTY	TOTAL SHEETS	SHEET NO.
311	652X-N-3	DUPAGE	34	27
TC-10 CONTRACT NO. 60L22				
FED. ROAD DIST. NO. 1 ILLINOIS FED. AID PROJECT				

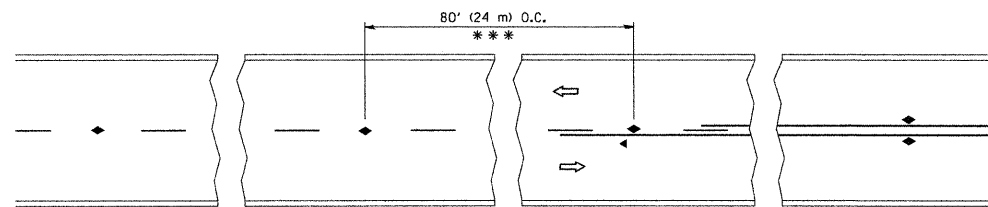

*** REDUCE TO 40' (12 m) O.C. ON CURVES WITH POSTED OR ADVISORY SPEED 45 M.P.H. (70 km/h) OR LESS.

TWO-LANE/TWO-WAY

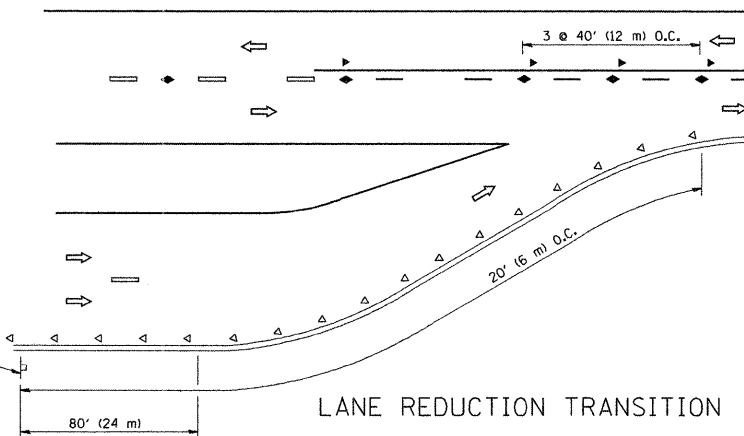

LANE REDUCTION TRANSITION

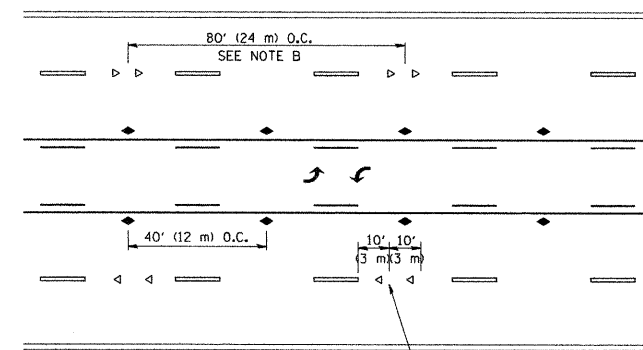

TWO-WAY LEFT TURN

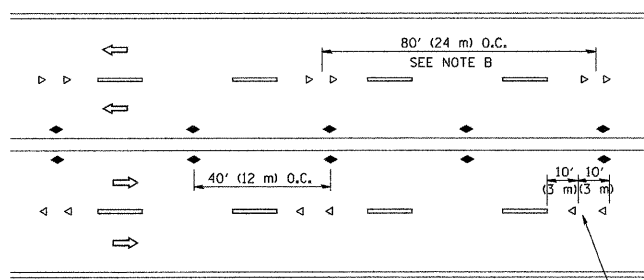

MULTI-LANE/UNDIVIDED

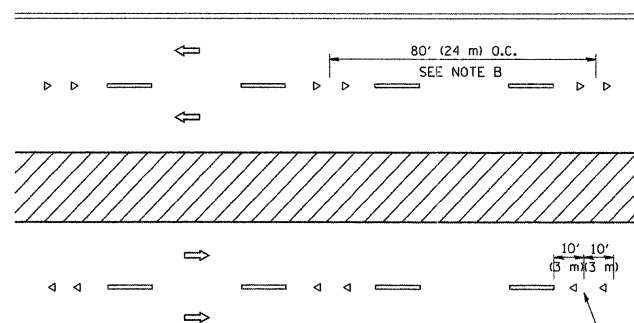

MULTI-LANE/DIVIDED

GENERAL NOTES

1. MARKERS USED WITH DASHED LINES SHALL BE CENTERED IN THE GAP BETWEEN SEGMENTS.
2. MARKERS USED ADJACENT TO SOLID LINES SHALL BE OFFSET 2 TO 3 (50 TO 75) TOWARD TRAFFIC AS SHOWN.
3. MARKERS THROUGH TANGENTS LESS THAN 500' (150 m) IN LENGTH BETWEEN CURVES SHALL BE INSTALLED AT THE LESSER OF THE TWO CURVE SPACINGS.

SYMBOLS

- YELLOW STRIPE
- ▬ WHITE STRIPE
- ◀ ONE-WAY AMBER MARKER
- ◁ ONE-WAY CRYSTAL MARKER (W/O)
- ◆ TWO-WAY AMBER MARKER

LANE MARKER NOTES

- A. USE DOUBLE LANE LINE MARKERS SPACED AS SHOWN.
- B. REDUCE TO 40' (12 m) O.C. ON CURVES WHERE ADVISORY SPEEDS ARE 10 M.P.H. (20 km/h) LOWER THAN POSTED SPEEDS.

DESIGN NOTES

1. DOUBLE LANE LINE MARKERS SHALL BE USED UNLESS SPECIFIED OTHERWISE.
2. EXCEPT AS SHOWN ON THE LANE REDUCTION TRANSITION AND FREEWAY EXIT RAMP DETAIL, MARKERS ARE NOT TO BE SPECIFIED ON RIGHT EDGE LINES.
3. THE EXACT MARKER LIMITS, SPACING, AND COLOR SHOULD BE INCLUDED IN THE PLANS.
4. MARKERS SHOULD NOT BE USED ALONGSIDE CURBS EXCEPT FOR EXTREMELY SHORT SECTIONS OF CURBS WHERE NOT MORE THAN TWO MARKERS WOULD BE INVOLVED.

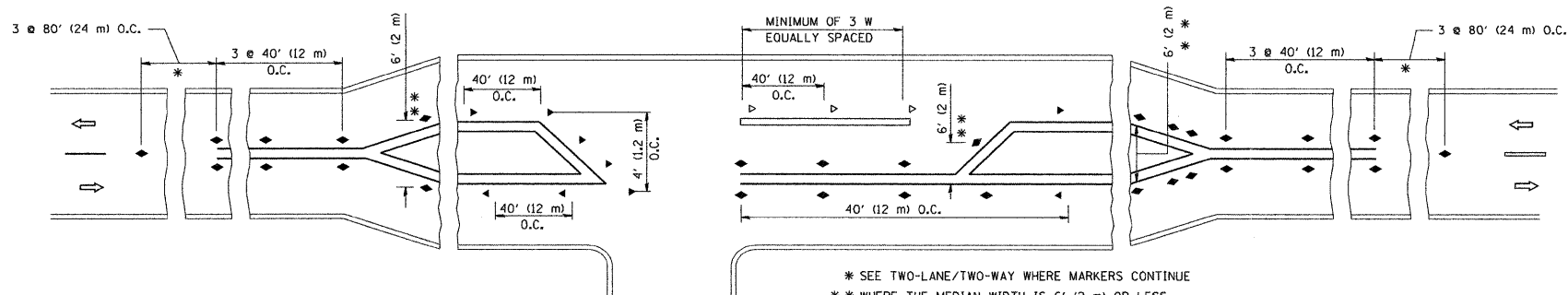

LEFT TURN

* SEE TWO-LANE/TWO-WAY WHERE MARKERS CONTINUE
 ** WHERE THE MEDIAN WIDTH IS 6' (2 m) OR LESS USE TWO-WAY MARKERS.

All dimensions are in inches (millimeters) unless otherwise shown.

FILE NAME =	USER NAME = drivakosgn	DESIGNED -	REVISED - T. RAMMACHER 09-19-94	STATE OF ILLINOIS DEPARTMENT OF TRANSPORTATION	TYPICAL APPLICATIONS RAISED REFLECTIVE PAVEMENT MARKERS (SNOW-PLOW RESISTANT)			F.A.P. RTE.	SECTION	COUNTY	TOTAL SHEETS	SHEET NO.
c:\pwork\pwork\drivakosgn\d0188315\td	ldgn	DRAWN -	REVISED - T. RAMMACHER 03-12-99		311	652X-N-3	DUPAGE	34	28			
		CHECKED -	REVISED - T. RAMMACHER 01-06-00		TC-11			CONTRACT NO. 60L22				
		DATE -	REVISED - C. JUCIUS 09-09-09		SCALE: NONE	SHEET NO. 1 OF 1 SHEETS	STA.	TO STA.	FED. ROAD DIST. NO. 1 [ILLINOIS] FED. AID PROJECT			

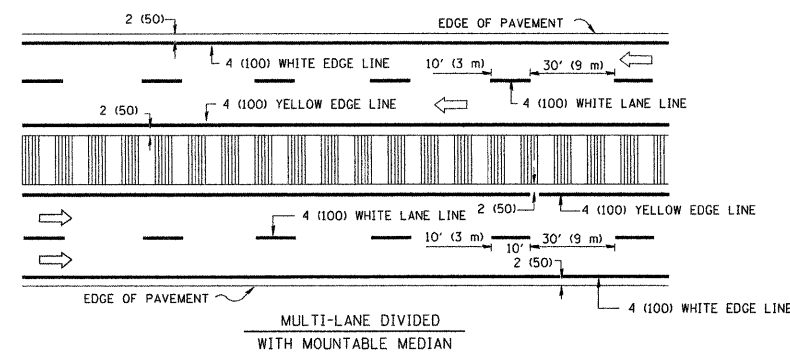
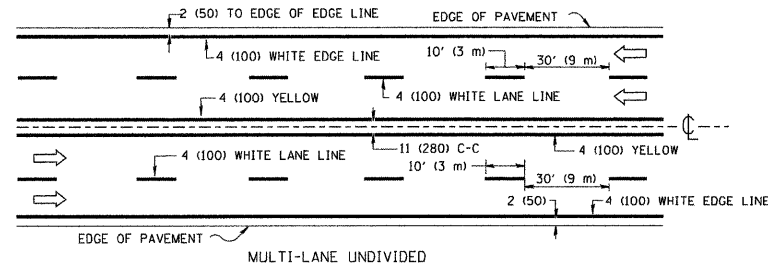
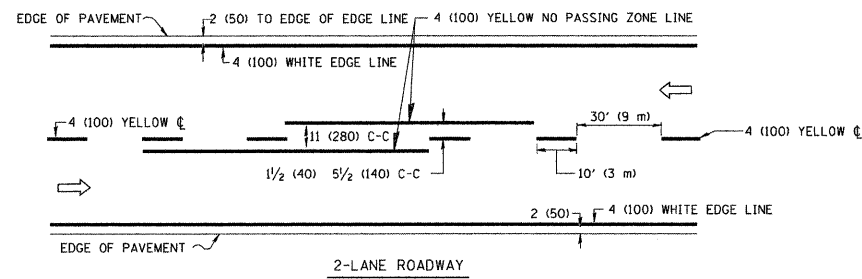

NOTE: MEDIANS WITH BARRIER CURB DO NOT REQUIRE AN EDGE LINE

TYPICAL LANE AND EDGE LINE MARKING

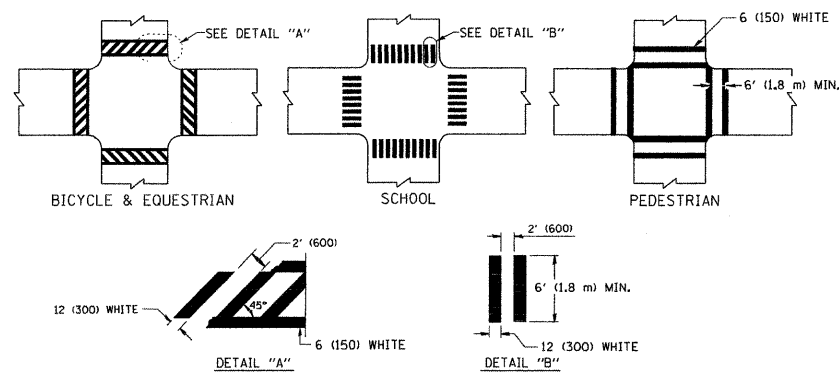

TYPICAL CROSSWALK MARKING

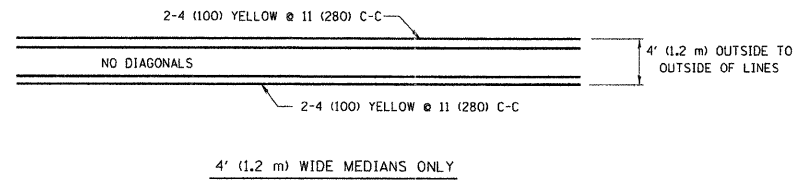

4' (1.2 m) WIDE MEDIANS ONLY

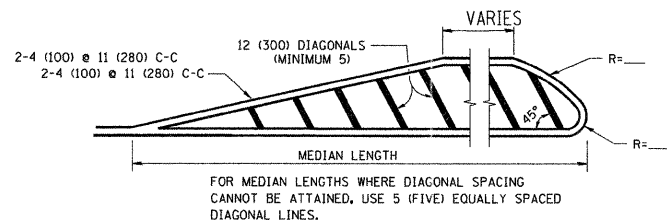

FOR MEDIAN LENGTHS WHERE DIAGONAL SPACING CANNOT BE ATTAINED, USE 5 (FIVE) EQUALLY SPACED DIAGONAL LINES.
DIAGONAL LINE SPACING: 50' (15 m) C-C (LESS THAN 30MPH (50 km/h))
75' (25 m) C-C 30MPH (50 km/h) TO 45MPH (70 km/h)
150' (45 m) C-C (MORE THAN 45MPH (70 km/h))

MEDIANS OVER 4' (1.2 m) WIDE

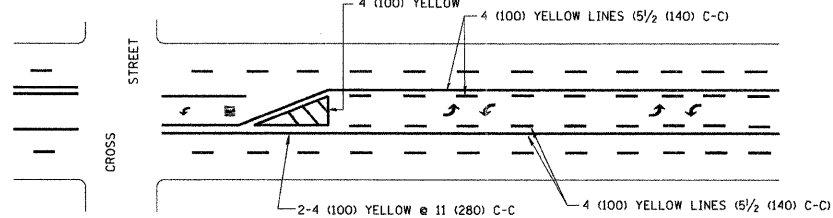

A MINIMUM OF TWO PAIRS OF TURN ARROWS SHALL BE USED, WHITE IN COLOR. ADDITIONAL PAIRS SHALL BE PLACED AT 200' (60 m) TO 300' (90 m) INTERVALS.

MEDIAN WITH TWO-WAY LEFT TURN LANE

TYPICAL PAINTED MEDIAN MARKING

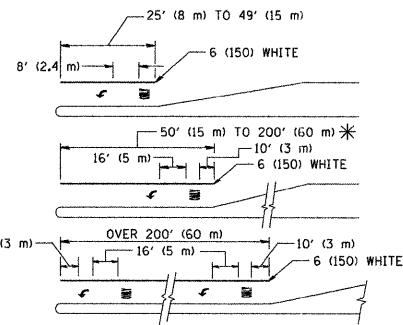

FULL SIZE LETTERS 8' (2.4 m) AND ARROWS SHALL BE USED.
AREA = 15.6 SQ. FT. (1.5 m²) ONLY AREA = 20.8 SQ. FT. (1.9 m²)

* TURN LANES IN EXCESS OF 400' (120 m) IN LENGTH MAY HAVE AN ADDITIONAL SET OF ARROW - "ONLY" INSTALLED MIDWAY BETWEEN THE OTHER TWO SETS OF ARROW - "ONLY".

TYPICAL LEFT (OR RIGHT) TURN LANE

TYPICAL TURN LANE MARKING

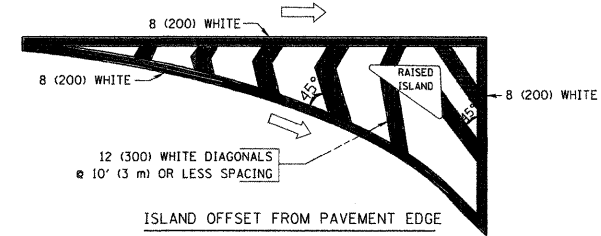

ISLAND OFFSET FROM PAVEMENT EDGE

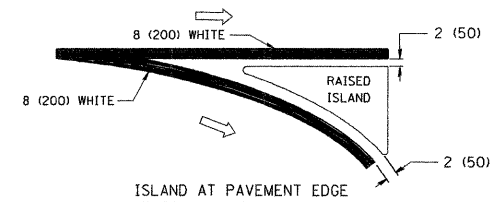

ISLAND AT PAVEMENT EDGE

TYPICAL ISLAND MARKING

TYPE OF MARKING	WIDTH OF LINE	PATTERN	COLOR	SPACING / REMARKS
CENTERLINE ON 2 LANE PAVEMENT	4 (100)	SKIP-DASH	YELLOW	10' (3 m) LINE WITH 30' (9 m) SPACE
CENTERLINE ON MULTI-LANE UNDIVIDED PAVEMENT	2 @ 4 (100)	SOLID	YELLOW	11 (280) C-C
NO PASSING ZONE LINES: FOR ONE DIRECTION FOR BOTH DIRECTIONS	4 (100) 2 @ 4 (100)	SOLID SOLID	YELLOW YELLOW	5 1/2' (140) C-C FROM SKIP-DASH CENTERLINE 11 (280) C-C OMIT SKIP-DASH CENTERLINE BETWEEN
LANE LINES	4 (100) 5 (125) ON FREEWAYS	SKIP-DASH SKIP-DASH	WHITE WHITE	10' (3 m) LINE WITH 30' (9 m) SPACE
DOTTED LINES (EXTENSIONS OF CENTER, LANE OR TURN LANE MARKINGS)	SAME AS LINE BEING EXTENDED	SKIP-DASH	SAME AS LINE BEING EXTENDED	2' (600) LINE WITH 6' (1.8 m) SPACE
EDGE LINES	4 (100)	SOLID	YELLOW-LEFT WHITE-RIGHT	OUTLINE MOUNTABLE MEDIANS IN YELLOW; EDGE LINES ARE NOT USED NEXT TO BARRIER CURB
TURN LANE MARKINGS	6 (150) LINE; FULL SIZE LETTERS & SYMBOLS (8' (2.4m))	SOLID	WHITE	SEE TYPICAL TURN LANE MARKING DETAIL
TWO WAY LEFT TURN MARKING	2 @ 4 (100) EACH DIRECTION 8' (2.4m) LEFT ARROW	SKIP-DASH AND SOLID IN PAIRS	YELLOW WHITE	10' (3 m) LINE WITH 30' (9 m) SPACE FOR SKIP-DASH; 5 1/2' (140) C-C BETWEEN SOLID LINE AND SKIP-DASH LINE SEE TYPICAL TWO-WAY LEFT TURN MARKING DETAIL
CROSSWALK LINES (PEDESTRIAN) A. DIAGONALS (BIKE & EQUESTRIAN) B. LONGITUDINAL BARS (SCHOOL)	2 @ 6 (150) 12 (300) @ 45° 12 (300) @ 90°	SOLID SOLID SOLID	WHITE WHITE WHITE	NOT LESS THAN 6' (1.8 m) APART 2' (600) APART 2' (600) APART SEE TYPICAL CROSSWALK MARKING DETAILS.
STOP LINES	24 (600)	SOLID	WHITE	PLACE 4' (1.2 m) IN ADVANCE OF AND PARALLEL TO CROSSWALK, IF PRESENT. OTHERWISE, PLACE AT DESIRED STOPPING POINT. PARALLEL TO CROSSROAD CENTERLINE, WHERE POSSIBLE
PAINTED MEDIANS	2 @ 4 (100) WITH 12 (300) DIAGONALS @ 45° NO DIAGONALS USED FOR 4' (1.2 m) WIDE MEDIANS	SOLID	YELLOW; TWO WAY TRAFFIC WHITE; ONE WAY TRAFFIC	11 (280) C-C FOR THE DOUBLE LINE SEE TYPICAL PAINTED MEDIAN MARKING.
GORE MARKING AND CHANNELIZING LINES	8 (200) WITH 12 (300) DIAGONALS @ 45°	SOLID	WHITE	DIAGONALS: 15' (4.5 m) C-C (LESS THAN 30MPH (50 km/h)) 20' (6 m) C-C 30MPH (50 km/h) TO 45MPH (70 km/h) 30' (9 m) C-C (OVER 45MPH (70 km/h))
RAILROAD CROSSING	24 (600) TRANSVERSE LINES; "RR" IS 6' (1.8 m) LETTERS; 16 (400) LINE FOR "X"	SOLID	WHITE	SEE STATE STANDARD 780001 AREA OF: "R"=3.6 SQ. FT. (0.33 m ²) EACH "X"=54.0 SQ. FT. (5.0 m ²)
SHOULDER DIAGONALS	12 (300) @ 45°	SOLID	WHITE - RIGHT YELLOW - LEFT	50' (15 m) C-C (LESS THAN 30MPH (50 km/h)) 75' (25 m) C-C (30 MPH (50 km/h) TO 45MPH (70 km/h)) 150' (45 m) C-C (OVER 45MPH (70 km/h))

FOR FURTHER DETAILS ON PAVEMENT MARKING REFER TO STANDARD SPECIFICATIONS FOR ROAD AND BRIDGE CONSTRUCTION AND STATE STANDARD 780001.

All dimensions are in inches (millimeters) unless otherwise shown.

FILE NAME =	USER NAME = drvakosgn	DESIGNED - EVERS	REVISED - T. RAMMACHER 10-27-94
c:\pwork\p1dot\drvakosgn\d0188315\td	3.dgn	DRAWN -	REVISED - C. JUCIUS 09-09-09
	PLOT SCALE = 50,000' / IN.	CHECKED -	REVISED -
	PLOT DATE = 9/9/2009	DATE - 03-19-90	REVISED -

STATE OF ILLINOIS
DEPARTMENT OF TRANSPORTATION

DISTRICT ONE
TYPICAL PAVEMENT MARKINGS

SCALE: NONE	SHEET NO. 1 OF 1 SHEETS	STA. TO STA.	F.A.P. RTE. 311	SECTION 652K-N-3	COUNTY DUPAGE	TOTAL SHEETS 34	SHEET NO. 29
			TC-13		CONTRACT NO. 60L22		
FED. ROAD DIST. NO. 1 [ILLINOIS] FED. AID PROJECT							

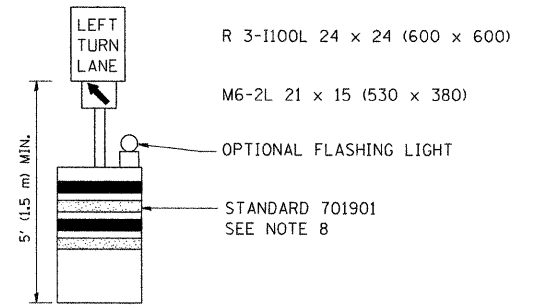
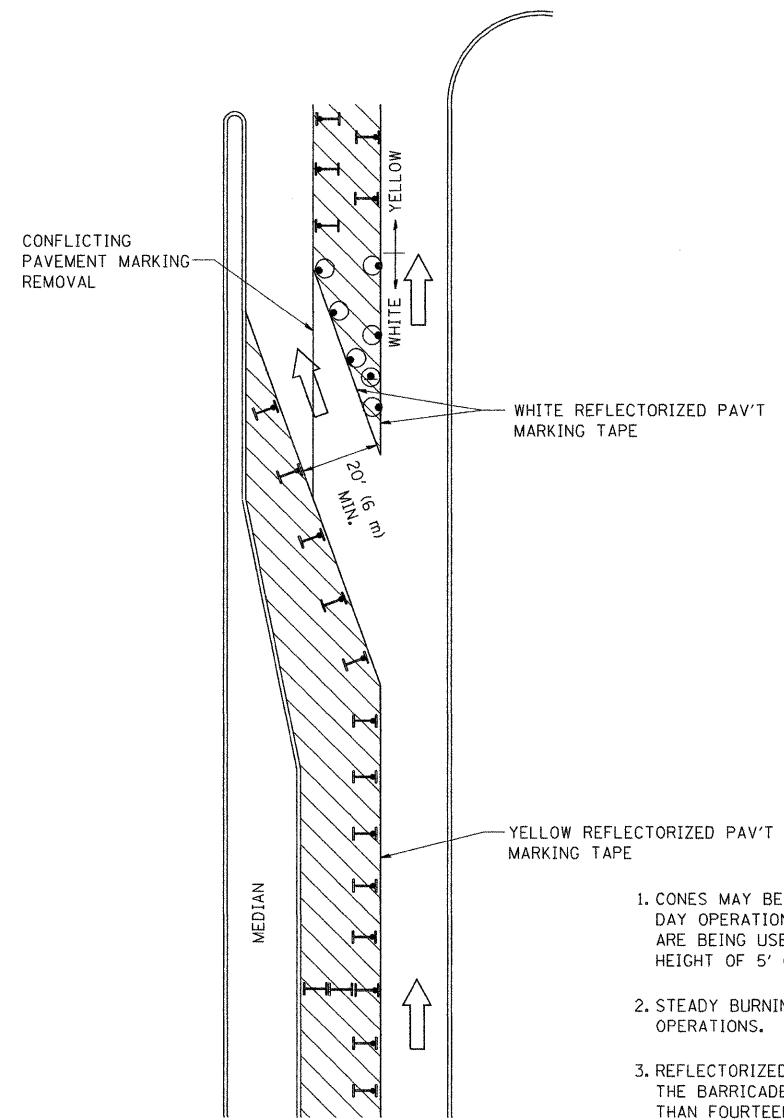







GENERAL NOTES

1. CONES MAY BE SUBSTITUTED FOR BARRICADES OR DRUMS AT HALF THE SPACING DURING DAY OPERATIONS. CONES SHALL BE A MINIMUM OF 28 (710) IN HEIGHT. WHEN CONES ARE BEING USED, THE "LEFT TURN LANE" SIGN MAY BE SKID MOUNTED AT A MINIMUM HEIGHT OF 5' (1.5 m).
2. STEADY BURNING LIGHTS WILL NOT BE REQUIRED ON BARRICADES OR DRUMS FOR DAY OPERATIONS. ALL LIGHTS SHALL BE MONODIRECTIONAL.
3. REFLECTORIZED TEMPORARY PAVEMENT MARKING TAPE SHALL BE PLACED THROUGHOUT THE BARRICADED AREA OF EACH TURN BAY WHERE THE CLOSURE TIME IS GREATER THAN FOURTEEN DAYS.
4. THIS APPLICATION ALSO APPLIES WHEN WORK IS BEING PERFORMED IN THE RIGHT LANE(S) AND THE RIGHT TURN BAY IS TO REMAIN OPEN. UNDER THIS CONDITION, "RIGHT TURN LANE" R3-100 24 x 24 (600 x 600) AND M6-2R 21 x 15 (530 x 380) SHALL BE USED.
5. THESE CONTROLS SHALL SUPPLEMENT MAINLINE TRAFFIC CONTROL FOR LANE CLOSURES.
6. LONGITUDINAL DIMENSIONS MAY BE ADJUSTED TO FIT FIELD CONDITIONS.
7. FORM OPER 725 IS REQUIRED.
8. IF A DRUM OR TYPE II BARRICADE WITH AN ATTACHED SIGN PANEL WHICH MEETS NCHRP 350 REQUIREMENTS IS NOT AVAILABLE, THE SIGNS SHALL BE MOUNTED, ABOVE THE BARRICADES, ON SEPARATE SIGNS SUPPORTS THAT MEET NCHRP 350 PREQUIREMENTS.
9. TRAFFIC CONTROL AND PROTECTION AT TURN BAYS (TO REMAIN OPEN TO TRAFFIC) SHALL BE INCLUDED IN THE COST SPECIFIED TRAFFIC CONTROL STANDARDS OR ITEMS.

All dimensions are in inches (millimeters) unless otherwise shown.

LEGEND

-  WORK AREA
-  LANE OPEN TO TRAFFIC
-  TYPE I OR II BARRICADE WITH STEADY BURN LIGHT
-  DRUM WITH STEADY BURN LIGHT
-  DRUM WITH SIGN (WITH OPTIONAL FLASHING LIGHT) SEE DETAIL
-  TYPE I OR II CHECK BARRICADE WITH FLASHING LIGHT

FILE NAME =	USER NAME = drivakosgn	REVISED - T. RAMMACHER 09-08-94	REVISED - R. BORO 09-14-09
c:\pwork\pwork\DRIVAKOSGN\08100315\0914.dgn		REVISED - A. HOUSEH 11-07-95	REVISED -
	PLOT SCALE = 49.9999' / IN.	REVISED - A. HOUSEH 10-12-96	REVISED -
	PLOT DATE = 9/14/2009	REVISED - T. RAMMACHER 01-06-00	REVISED -

**STATE OF ILLINOIS
DEPARTMENT OF TRANSPORTATION**

**TRAFFIC CONTROL AND PROTECTION AT TURN BAYS
(TO REMAIN OPEN TO TRAFFIC)**

F.A.P. RTE.	SECTION	COUNTY	TOTAL SHEETS	SHEET NO.
311	652X-N-3	DUPAGE	34	30
TC-14			CONTRACT NO. 60L22	
FED. ROAD DIST. NO. 1 (ILLINOIS) FED. AID PROJECT				

SCALE: NONE SHEET NO. 1 OF 1 SHEETS STA. TO STA.

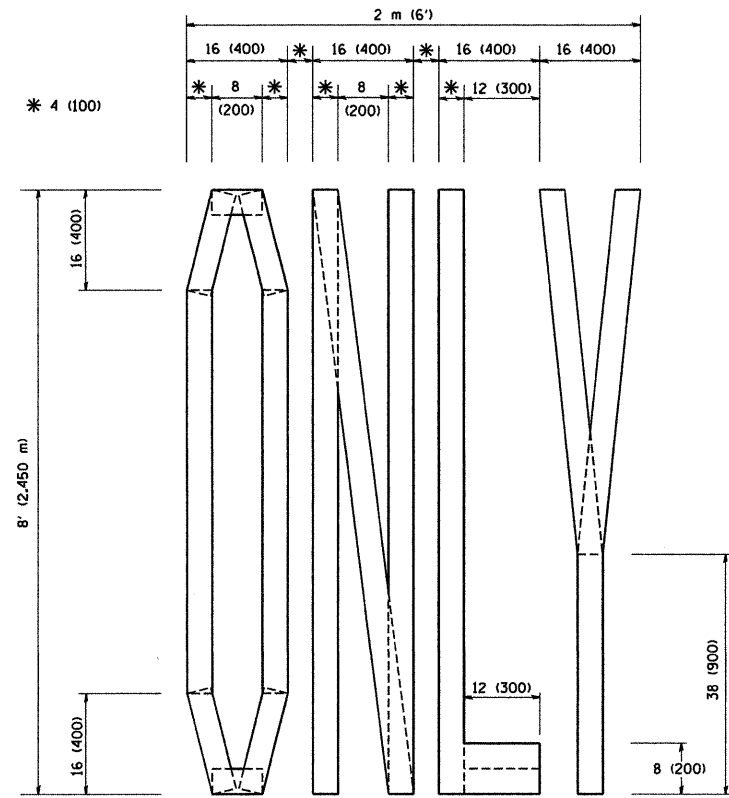

QUANTITY
 4 (100) LINE = 64.1 ft. (19.7 m)
 21.1 sq. ft. (1.97 sq. m)

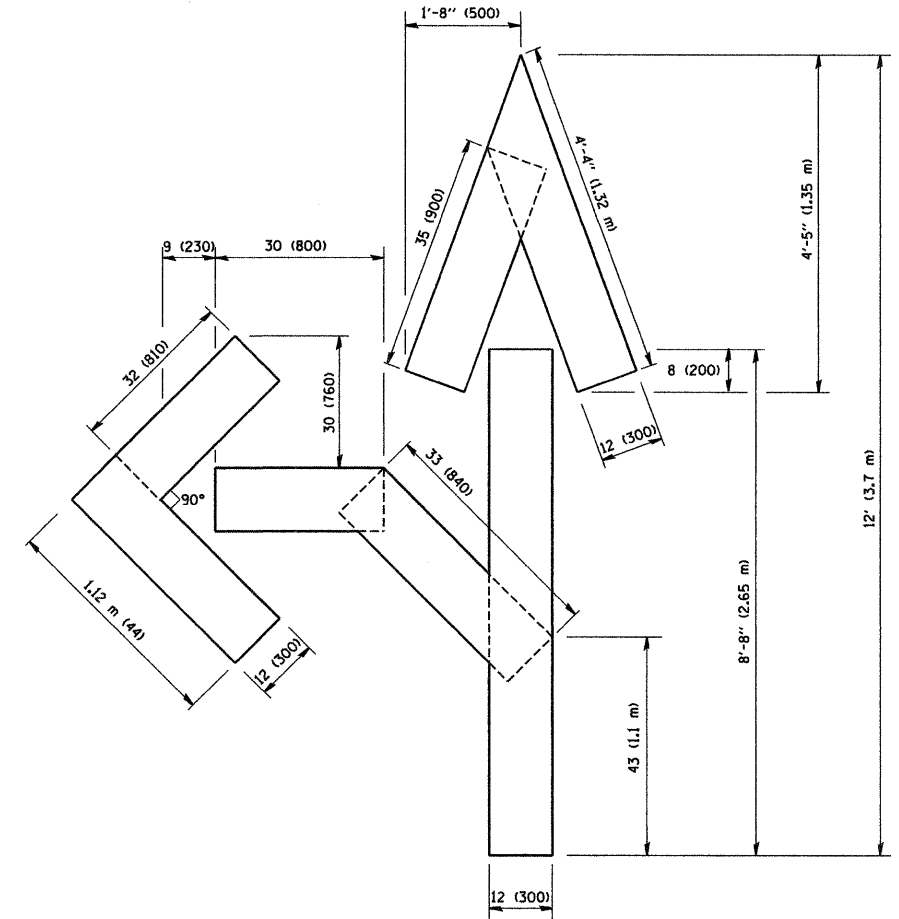

QUANTITY
 4 (100) LINE = 82.5 ft. (25.3 m)
 27.5 sq. ft. (2.53 sq. m)

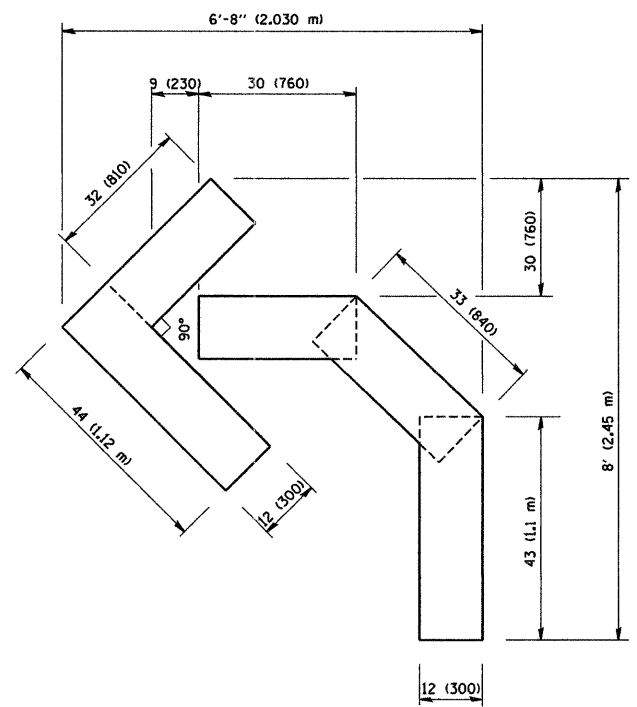

QUANTITY
 4 (100) LINE = 45.5 ft. (13.9 m)
 15.2 sq. ft. (1.39 sq. m)

All dimensions are in inches (millimeters) unless otherwise shown.

FILE NAME = W:\diststd\22x34\tbl6.dgn	USER NAME = gagienobt	DESIGNED -	REVISED -T. RAMMACHER 06-05-96
		DRAWN -	REVISED -T. RAMMACHER 11-04-97
	PLOT SCALE = 50,0000 ' / IN.	CHECKED -	REVISED -T. RAMMACHER 03-02-98
	PLOT DATE = 1/4/2008	DATE - 09-18-94	REVISED -E. GOMEZ 08-28-00

**STATE OF ILLINOIS
 DEPARTMENT OF TRANSPORTATION**

**PAVEMENT MARKING LETTERS AND SYMBOLS
 FOR TRAFFIC STAGING**

SCALE: NONE SHEET NO. 1 OF 1 SHEETS STA. TO STA.

F.A.P. RTE.	SECTION	COUNTY	TOTAL SHEETS	SHEET NO.
311	652X-N-3	DUPAGE	34	31
TC-16				
FED. ROAD DIST. NO. 1 [ILLINOIS] FED. AID PROJECT				

CONTRACT NO. 60L22

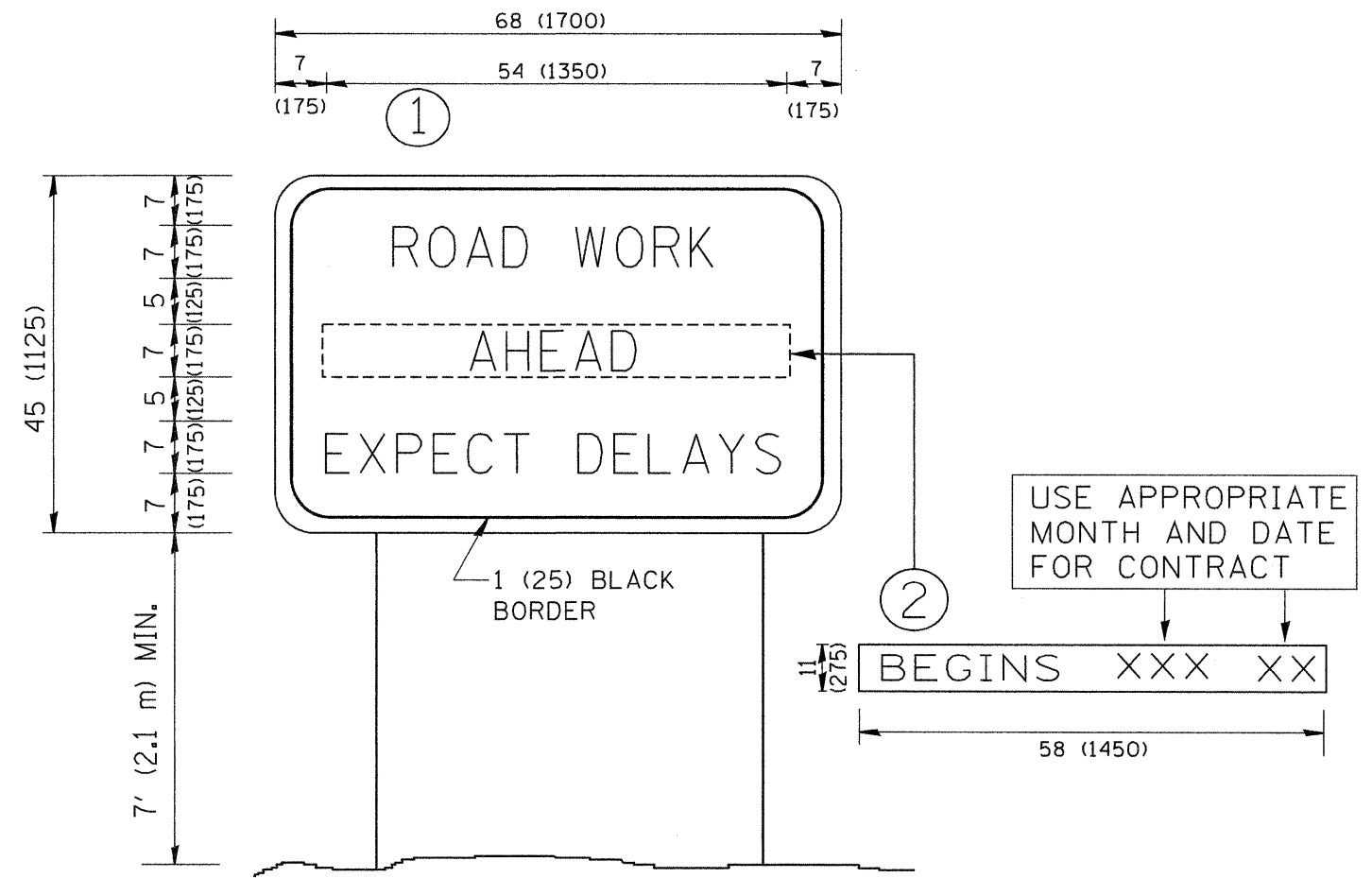

NOTES:

1. USE BLACK LETTERING ON ORANGE BACKGROUND.
2. ERECT SIGNS IN ADVANCE OF THE LOCATION FOR THE "ROAD CONSTRUCTION AHEAD" SIGN AT LOCATIONS AS DIRECTED BY THE ENGINEER.
3. ERECT SIGN ① WITH INSTALLED PANEL ② ONE WEEK PRIOR TO THE START OF CONSTRUCTION.
4. REMOVE PANEL ② SOON AFTER THE START OF CONSTRUCTION.
5. SEE SPECIAL PROVISION FOR "TEMPORARY INFORMATION SIGNING" FOR ADDITIONAL INFORMATION.
6. ONE SIGN ASSEMBLY EQUALS 25.70 SQ. FT. (2.3 SQ. M.)
7. SHALL BE PAID FOR AS TEMPORARY INFORMATION SIGNING.

ALL DIMENSIONS ARE IN INCHES (MILLIMETERS) UNLESS OTHERWISE SHOWN.

FILE NAME = W:\disttd\22x34\to22.dgn	USER NAME = gaglienobt	DESIGNED -	REVISED - R. MIRS 09-15-97
		DRAWN -	REVISED - R. MIRS 12-11-97
	PLOT SCALE = 50.000' / IN.	CHECKED -	REVISED - T. RAMMACHER 02-02-99
	PLOT DATE = 1/4/2008	DATE -	REVISED - C. JUCIUS 01-31-07

**STATE OF ILLINOIS
DEPARTMENT OF TRANSPORTATION**

**ARTERIAL ROAD
INFORMATION SIGN**

SCALE: NONE SHEET NO. 1 OF 1 SHEETS STA. TO STA.

F.A.P. RTE. 311	SECTION 652X-N-3	COUNTY DUPAGE	TOTAL SHEETS 34	SHEET NO. 32
TC-22		CONTRACT NO. 60L22		
FED. ROAD DIST. NO. 1 ILLINOIS FED. AID PROJECT				

LOOPS NEXT TO SHOULDERS

PROVIDE A PAVEMENT REPLACEMENT NOTE WHICH SHOULD EQUAL 3' (900 mm) X WIDTH OF PAVED SHOULDER.

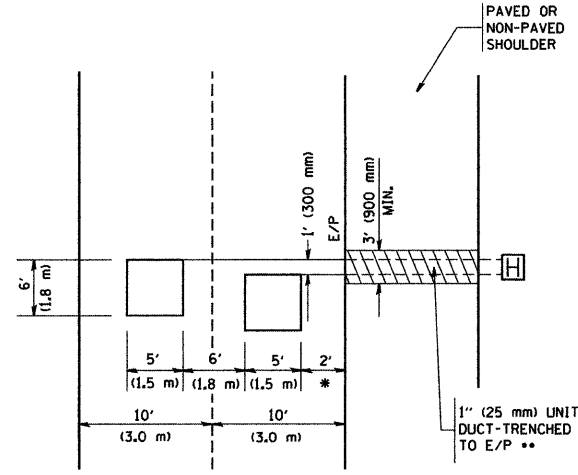

* = (600 mm)

** UNIT DUCT IS TO BE SHOWN ON PLAN SHEETS BUT SHALL NOT BE INCLUDED IN THE PAY ITEMS.

**LEFT TURN LANES WITH MEDIANS
VOLUME DENSITY ("FAR OUT" DETECTION)
ON SAME APPROACH
(PROTECTED / PERMITTED LEFT TURN PHASING)**

HANDHOLE LOCATION MAY VARY DEPENDING ON GEOMETRICS AND DESIGN OF TRAFFIC SIGNALS. HEAVY-DUTY HANDHOLES TO BE USED WHEN THE MEDIAN IS MOUNTABLE. REFER TO STANDARD 814001 TO ENSURE THAT HANDHOLE FITS IN MEDIAN.

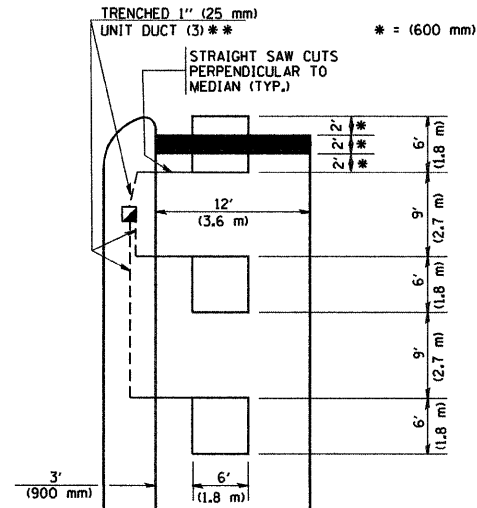

** UNIT DUCT IS TO BE SHOWN ON PLAN SHEETS BUT SHALL NOT BE INCLUDED IN THE PAY ITEMS.

NOTE: DUAL LEFT TURNS NOT SHOWN REFER TO PLAN SHEET FOR DETECTOR LOOP REPLACEMENT

**LEFT TURN LANES WITHOUT MEDIANS
VOLUME DENSITY ("FAR OUT" DETECTION)
ON SAME APPROACH
(PROTECTED / PERMITTED LEFT TURN PHASING)**

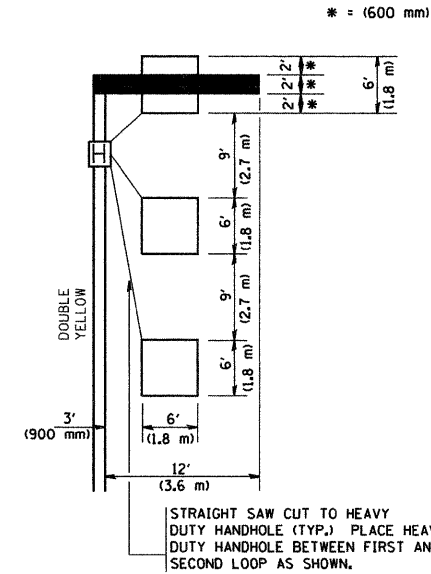

NOTE: DUAL LEFT TURNS NOT SHOWN REFER TO PLAN SHEET FOR DETECTOR LOOP REPLACEMENT

**ARTERIAL-VOLUME DENSITY ("FAR OUT" DETECTION)
CROSS STREET-VOLUME DENSITY ("FAR OUT" DETECTION)**

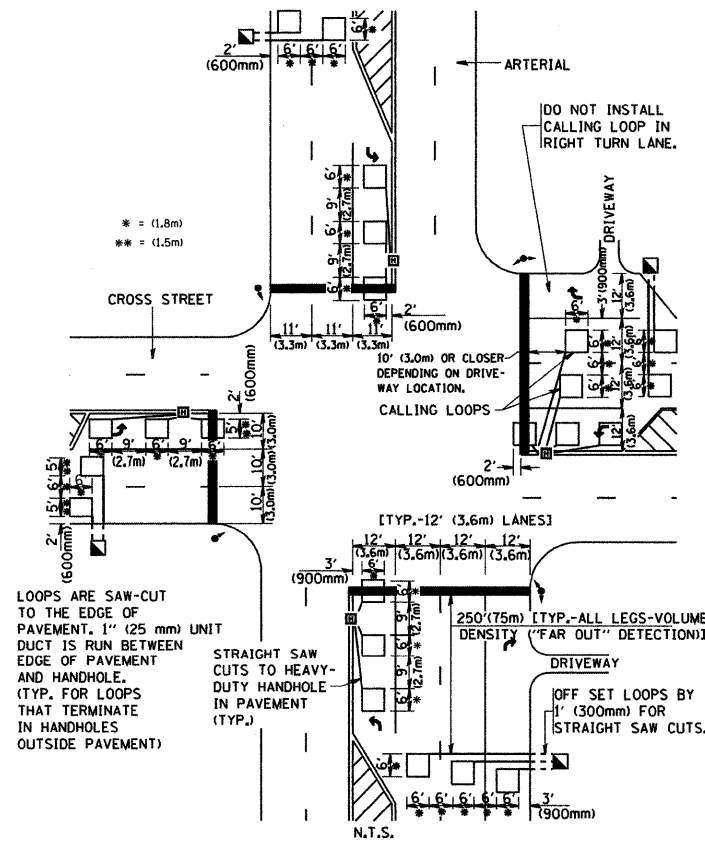

DETAIL 1
N.T.S.

**ARTERIAL-VOLUME DENSITY ("FAR OUT" DETECTION)
CROSS STREET-NON VOLUME DENSITY ("UPTIGHT" PRESENCE DETECTION)**

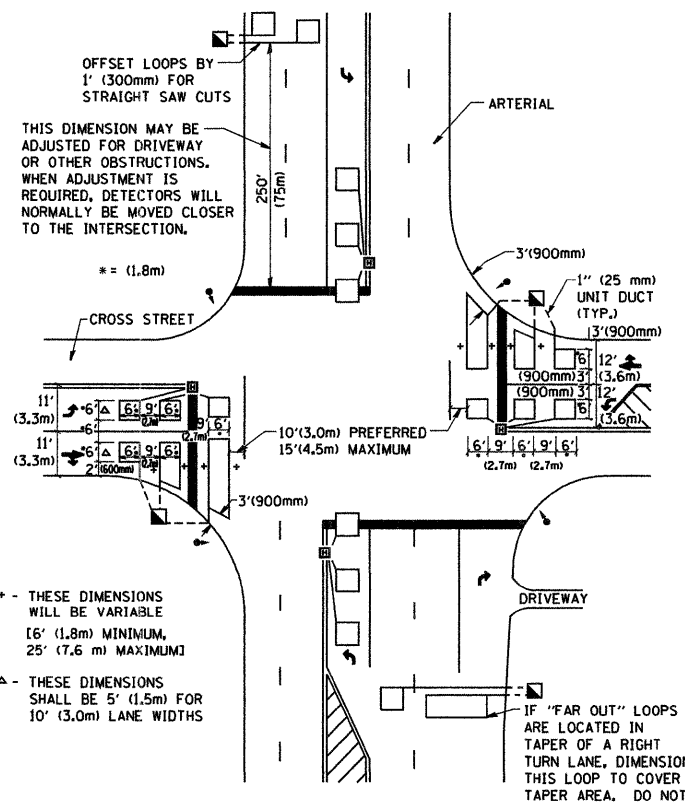

DETAIL 2
N.T.S.

NOTES:

VEHICLES LOOP DETECTORS

- * ALL LEAD IN CABLE SHALL BE TWO CONDUCTOR NO. 14 TWISTED, SHIELDED.
- * EACH DETECTOR LOOP SHALL HAVE ITS OWN SAW CUT FROM THE LOOP TO THE EDGE OF PAVEMENT OR TO A HANDHOLE IN THE PAVEMENT.
- * EACH DETECTOR LOOP SHALL HAVE ITS OWN ONE INCH (25 mm) UNIT DUCT BETWEEN THE EDGE OF PAVEMENT AND THE FIRST HANDHOLE OR JUNCTION BOX. EACH UNIT DUCT RUN SHALL BE SHOWN ON THE PLANS BY THE DESIGNER, BUT SHALL NOT BE PAID FOR SEPARATELY. THIS ITEM IS INCIDENTAL TO THE PAY ITEM FOR DETECTOR LOOPS.
- * ONE DIMENSION OF ALL DETECTOR LOOPS SHALL BE SIX FEET (1.8 m)
- * EACH LANE OF NON-LOCKING, PRESENCE DETECTION AND EACH LANE OF A DOUBLE LEFT TURN LANE REQUIRES A SEPARATE INDUCTIVE LOOP DETECTOR AND LEAD IN CABLE.
- * WHEN NON-LOCKING, PRESENCE DETECTION IS USED, MORE THAN ONE LOOP PER LANE IS REQUIRED BEHIND THE STOP BAR (i.e. 1-1/2, 1-3/4, 2).
- * WHEN SYSTEM LOOPS ARE REQUIRED ON AN APPROACH OF AN INTERSECTION, THE LOOPS USED FOR VOLUME DENSITY AND INTERSECTION TIMING SHALL ALSO BE USED AS SYSTEM DETECTORS. EACH ONE OF THESE TYPE OF LOOPS REQUIRES A SEPARATE TWO CONDUCTOR NO. 14 TWISTED SHIELDED CABLE AND A SEPARATE INDUCTIVE LOOP DETECTOR WHEN NEW CONTROLLERS ARE UTILIZED. THE DESIGNER SHALL LABEL THESE TYPES OF LOOPS AS "INTERSECTION AND SAMPLING (SYSTEM) DETECTORS" ON THE SIGNAL LAYOUT, THE INTERCONNECT PLAN AND THE SYSTEM CABLE PLAN. WHEN AN EXISTING CONTROLLER IS UTILIZED FOR THIS TYPE OF DETECTION, THE PAY ITEM "INDUCTIVE LOOP DETECTOR WITH SYSTEM OUTPUT" SHOULD BE USED.

PLACEMENT OF DETECTORS

THE FOLLOWING FIGURES REPRESENT THE MOST COMMON DETECTOR LOOP LOCATIONS AND SIZES. ADJUSTMENTS WILL BE NECESSARY FOR SPECIFIC GEOMETRIC CONSIDERATIONS.

LOCATIONS AND DIMENSIONS OF DETECTOR LOOPS ARE REQUIRED ON ALL SIGNAL LAYOUT PLAN SHEETS.

"FAR OUT" DETECTION REFERS TO LOCKING, PRESENCE TYPE DETECTION LOCATED IN THRU LANES, RIGHT TURN LANES, AND RIGHT TURN LANE TAPER AREAS (IF APPLICABLE), USUALLY 250' (75 m) IN ADVANCE OF STOP BARS. "UPTIGHT" DETECTION REFERS TO NON-LOCKING PRESENCE TYPE DETECTION LOCATED IN ALL LANES AND 10'-15' (3.0 m-4.5 m) BEHIND THE CROSSING STREET'S EDGE OF PAVEMENT EXTENDED.

NOTE:

ALL DETAILS AND NOTES SHOWN ARE FROM THE I.D.O.T. DISTRICT 1 TRAFFIC SIGNAL DESIGN GUIDELINES DATED JANUARY 1995

THIS DRAWING HAS BEEN PREPARED TO ASSIST THE RESIDENT ENGINEER FOR ALL ROADWAY RESURFACING OR S.M.A.R.T. PROJECTS WHERE THE DIMENSIONS ARE NOT SHOWN ON THE PLANS AND THE FINAL LOCATIONS FOR CROSSWALKS OR STOP BARS ARE NOT DETERMINED.

FILE NAME = W:\ds\std\22x34\ts07.dgn	USER NAME = geglrenob	DESIGNED -	REVISED -	STATE OF ILLINOIS DEPARTMENT OF TRANSPORTATION	DISTRICT 1 - DETECTOR LOOP INSTALLATION DETAILS FOR ROADWAY RESURFACING	F.A.P. RTE. 311	SECTION 652X-N-3	COUNTY DUPAGE	TOTAL SHEETS 34	SHEET NO. 33		
PLOT SCALE = 60,00000' / IN.	CHECKED - R.K.F.	DATE -	REVISED -			SCALE: NONE	SHEET NO. 1 OF 1 SHEETS	STA.	TO STA.	CONTRACT NO. 60L22		
PLOT DATE = 1/4/2008	DATE -	REVISED -	REVISED -						FED. ROAD DIST. NO. 1 (ILLINOIS) FED. AID PROJECT			

FINAL SURVEY	SURVEYED	DATE
NOTE BOOK	PLOTTED	BY
NO.	DATE	
	AREAS CHECKED	

ORIGINAL SURVEY	SURVEYED	DATE
NOTE BOOK	PLOTTED	BY
NO.	DATE	
	AREAS CHECKED	

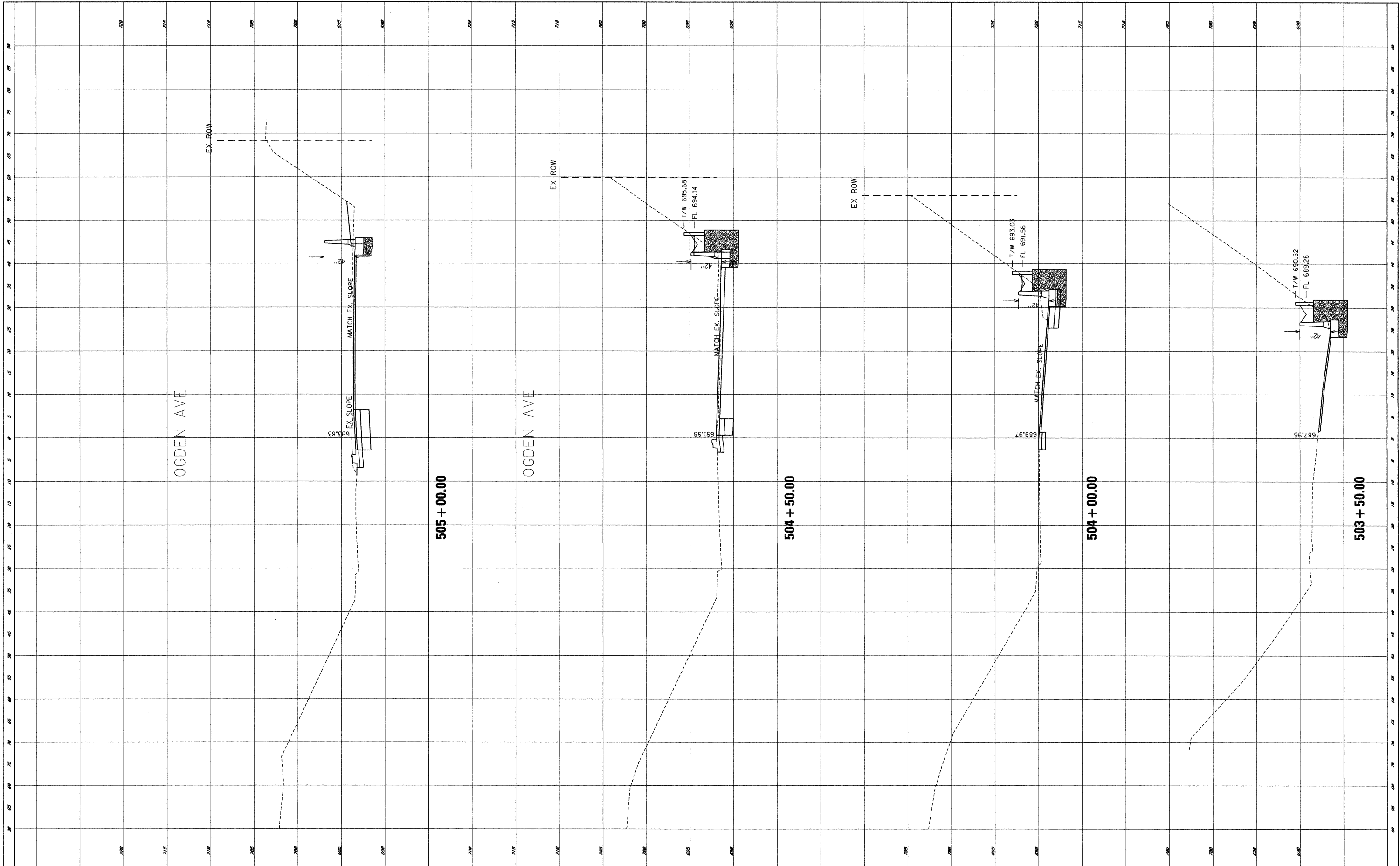

FILE NAME = P:\2009\ME09006_Ver-Var_Phi\CADD\W022_US34\B...
 USER NAME = Peter
 DESIGNED - CJD
 DRAWN - CJD
 CHECKED - RPD
 DATE -

DESIGNED - CJD
 DRAWN - CJD
 CHECKED - RPD
 DATE -

REVISIONS
 REVISED -
 REVISED -
 REVISED -
 REVISED -

**STATE OF ILLINOIS
 DEPARTMENT OF TRANSPORTATION**

**US RTE 34 (OGDEN AVE)
 PROPOSED CROSS SECTIONS**

SCALE: 1" = 20' SHEET NO. 1 OF 3 SHEETS STA. 503+50.00 TO STA. 505+00.00

F.A.P. RTE.	SECTION	COUNTY	TOTAL SHEETS	SHEET NO.
311	652X-N-3	DUPAGE	34	34
FED. ROAD DIST. NO. ILLINOIS FED. AID PROJECT				