

ROUTE	SECTION	COUNTY	TOTAL SHEETS	SHEET NUMBER
VARIOUS	2011-060-BR	COOK	49	38

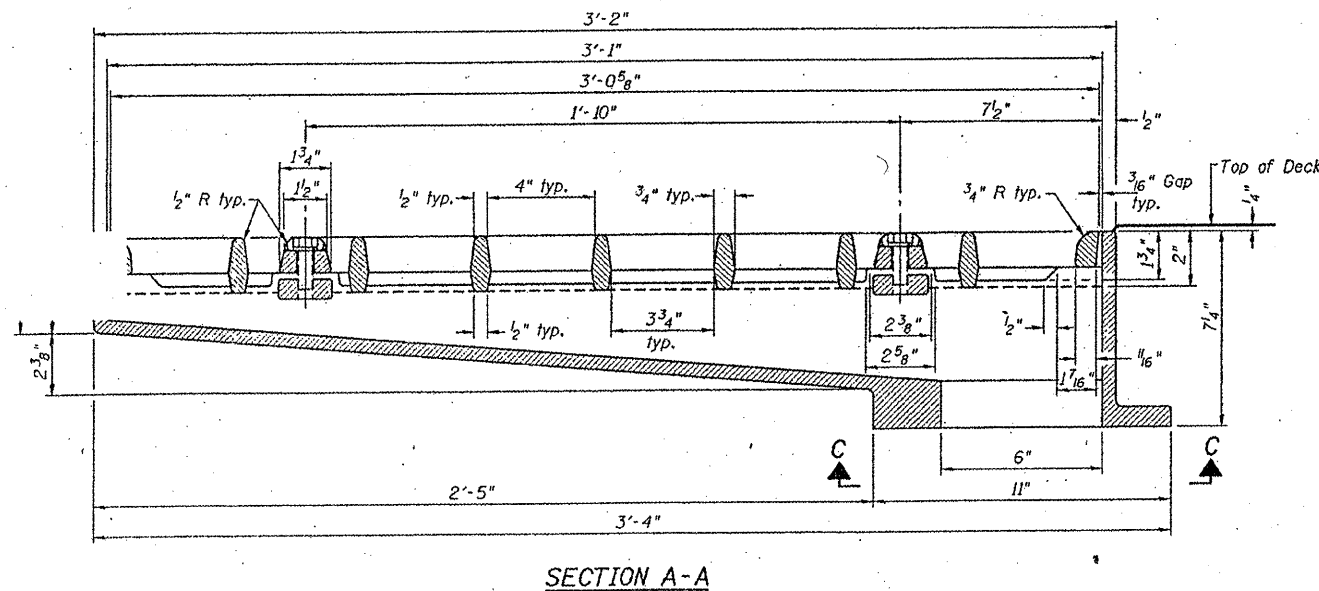

See sheet 7 for scupper location relative to parapet.

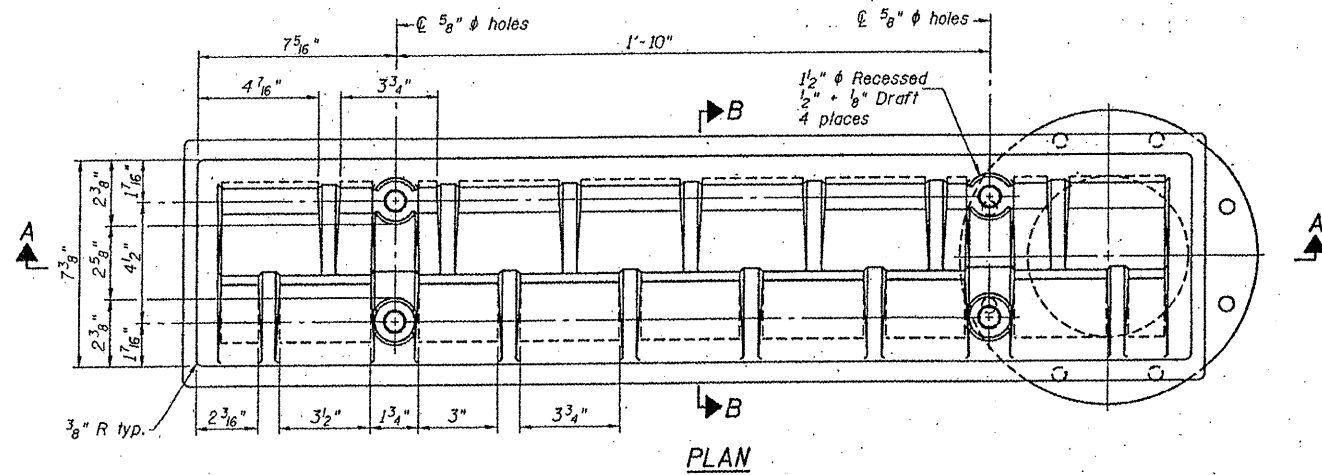
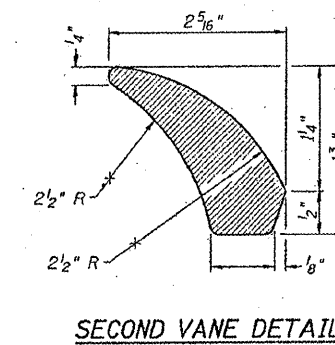
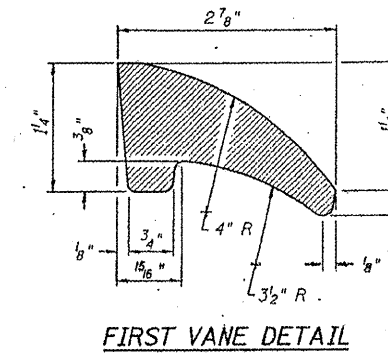
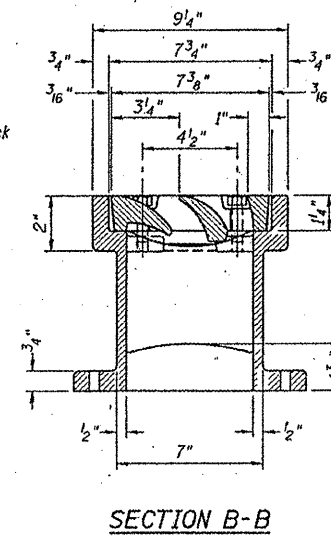
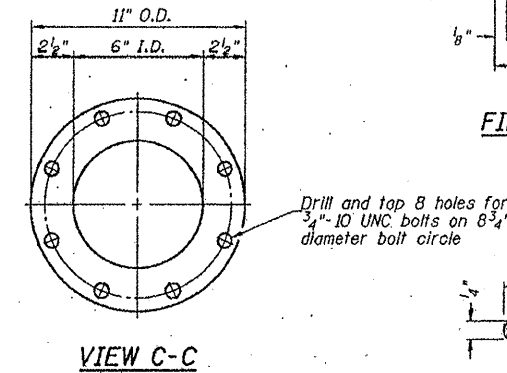
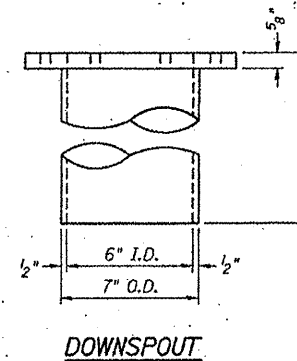
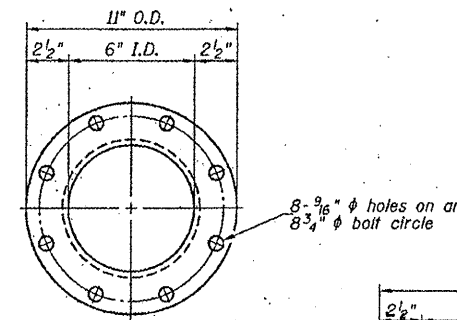
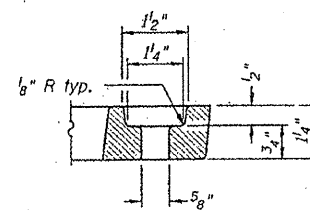

Notes: All cast iron parts shall be gray iron conforming to the requirements of AASHTO M 105, Class 35B.
 Bolts, anchor studs, washers and nuts shall conform to the requirements of ASTM A 307 and shall be galvanized according to AASHTO M 232.
 The grate, frame and downspout shall be galvanized according to AASHTO M 111 and ASTM A 385. Downspouts located on the exterior side of a painted steel fascia beam shall be painted with the finish coat specified for the exterior side of the fascia beam.
 As an alternate, bolts, anchor studs, washers and nuts may be stainless steel according to Article 1006.29(d) of the Standard Specifications.
 Structural steel weldments of equal sections and of the same configuration may be substituted for cast iron. Fillet or full penetration welds shall be used for the weldments. Details shall be submitted to the Engineer for approval.
 The Contractor shall take appropriate measures to assure that Protective Coat is not applied to the scupper.
 Cost of the Grate, Frame, Downspout, Anchor Studs, Bolts, Washers and Nuts including complete installation of the scupper shall be paid for at the contract unit price each for Drainage Scupper, DS-33.

FOR INFORMATION ONLY

ILLINOIS DEPARTMENT OF
 TRANSPORTATION
 STRUCTURAL REPAIRS
 PLAN & ELEVATION
 SN: 016-2031
 SHEET 2 OF 3