

**FIELD ENTRANCES**

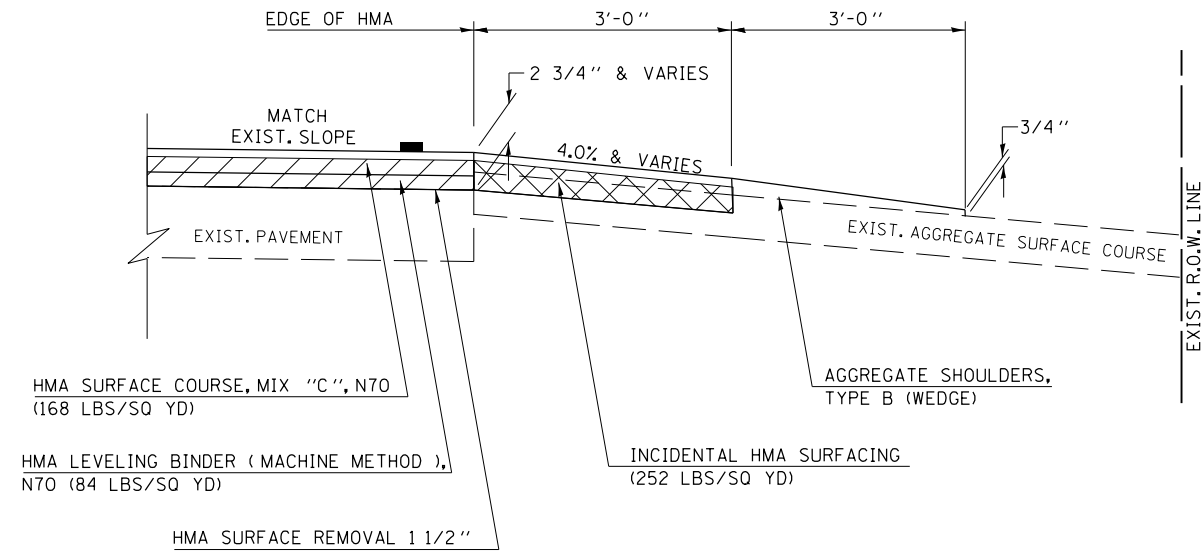

**PRIVATE AND COMMERCIAL ENTRANCES**

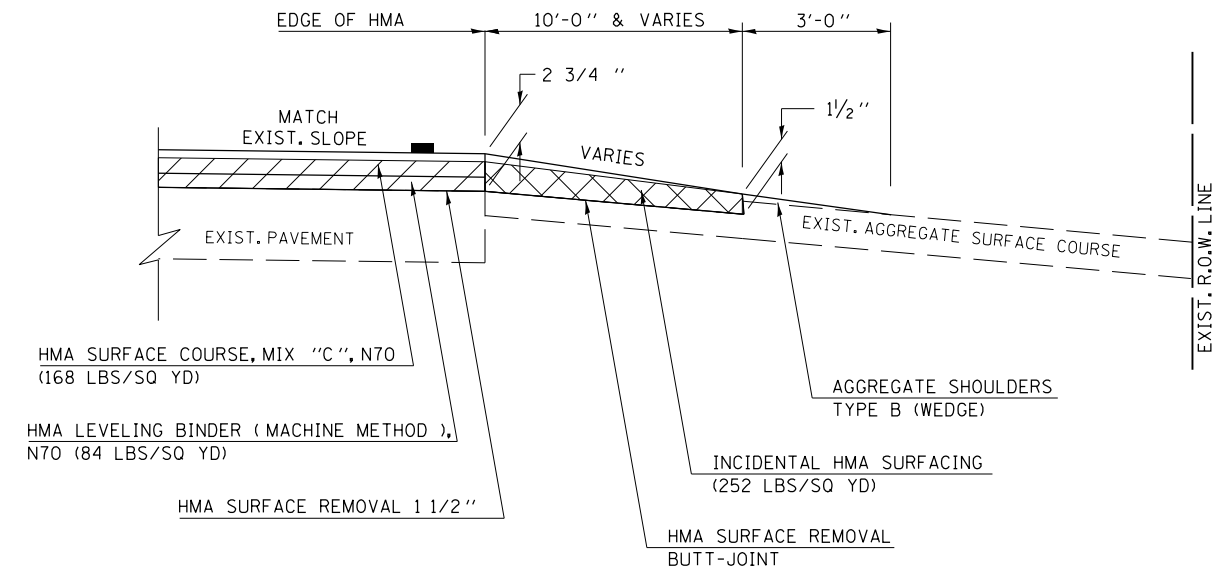

**MAILBOX TURNOUTS**

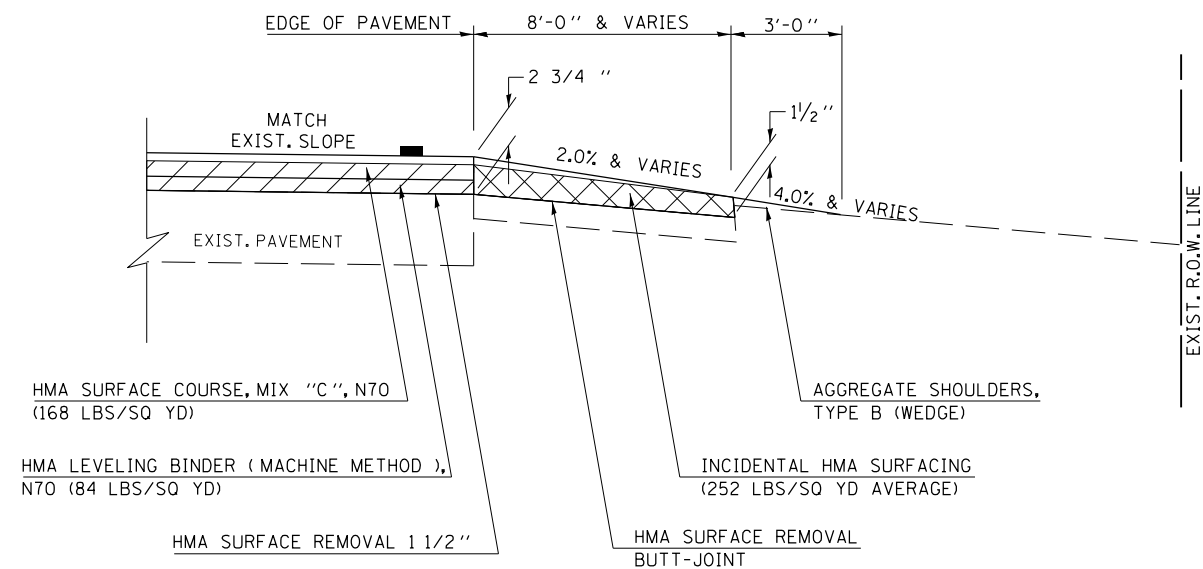

**GENERAL NOTES FOR INCIDENTAL ENTRANCES AND MAILBOX TURNOUTS**

1. THE EXISTING SURFACE SHALL BE PREPARED IN ACCORDANCE WITH SECTION 408 OF THE STANDARD SPECIFICATIONS.
2. AGGREGATE BASE COURSE, TYPE B, 6" (150) MIN. SHALL BE USED WHERE IN THE OPINION OF THE ENGINEER THERE IS NOT SUFFICIENT BASE MATERIAL FOR THE PROPOSED MAILBOX TURNOUTS. THIS MATERIAL SHALL GENERALLY BE USED TO WIDEN ALL EXISTING MAILBOX TURNOUTS OR TO CONSTRUCT NEW MAILBOX TURNOUTS WHERE NONE NOW EXISTS.
3. ANY NECESSARY WORK BEHIND THE INCIDENTAL HMA SURFACING SHALL BE AS SHOWN IN THE PLANS AND/OR AS DIRECTED BY THE ENGINEER.
4. EXISTING ENTRANCES OF AGGREGATE OR EARTH SHALL NOT RECEIVE A NEW HMA APRON WITHOUT PROPER APPROVAL THROUGH THE BUREAU OF OPERATIONS "POLICY ON PERMITS FOR ACCESS DRIVEWAYS TO STATE HIGHWAYS.

Note: All dimensions are in INCHES (millimeters) unless otherwise shown.

FILE NAME =	USER NAME = bucklesjj	DESIGNED -	REVISED -
et:\pw\work\p\dot\bucklesjj\0180660\0570706-sh1-Details.dgn		DRAWN -	REVISED -
	PLOT SCALE = 40.0000' / in.	CHECKED -	REVISED -
	PLOT DATE = 8/15/2011	DATE -	REVISED -

**STATE OF ILLINOIS  
DEPARTMENT OF TRANSPORTATION**

**INCIDENTAL DETAILS**

SCALE: SHEET NO. OF SHEETS STA. TO STA.

F.A.P. RTE.	SECTION	COUNTY	TOTAL SHEETS	SHEET NO.
326	129R5-3	Champaign	24	16
			CONTRACT NO. 70706	
ILLINOIS FED. AID PROJECT				