

F.A.U. RTE.	SECTION	COUNTY	TOTAL SHEETS	SHEET NO.
340	FAI 80 21 STRUCTURE 9	WILL	130	1
		ILLINOIS	CONTRACT NO. 62R30	

**ROUTE:** WHEELER AVE (F.A.U. 340)  
I-80 (F.A.I. 80)

**TRAFFIC DATA:** 2,749 (2032) MINOR COLLECTOR  
119,600 (2040) INTERSTATE

**POSTED /DESIGN SPEEDS:** 25 /30 MPH  
65 /70 MPH

STATE OF ILLINOIS 11-18-2022 LETTING ITEM 006

DEPARTMENT OF TRANSPORTATION

FOR INDEX OF SHEETS, SEE SHEET NO. 2

PROJECT LOCATED IN THE CITY OF JOLIET

# PROPOSED HIGHWAY PLANS

FAI ROUTE 80 (I-80)  
SECTION FAI 80 21 STRUCTURE 9  
PROJECT NHPP-0ZYP(871)  
BRIDGE REPLACEMENT AND ADA IMPROVEMENTS  
WILL COUNTY

C-91-117-22

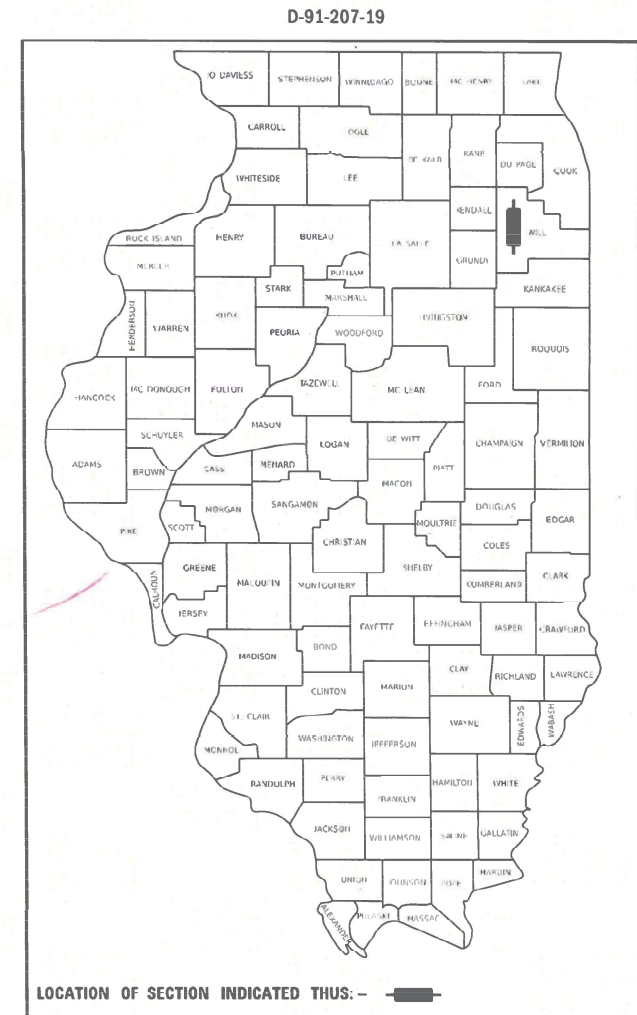

**AECOM**  
303 EAST WACKER DRIVE, SUITE 1400  
CHICAGO, IL 60601-5276  
PHONE: (312) 373-7700 FAX: (312) 373-6000



*Nader Mostafa* 7/14/2022  
NADER MOSTAFA DATE  
LICENSE EXPIRES 11/30/2023  
SHEET RANGE 1-37, 41-46, 120-130



*Demir Dabezic* 7/14/2022  
DEMIR DABEZIC DATE  
LICENSE EXPIRES 11/30/2022  
SHEET RANGE 58-88



*Thomas P. Gasser* 7/14/2022  
THOMAS P. GASSER DATE  
LICENSE EXPIRES 11/30/2023  
SHEET RANGE 51-57



*Moussa A. Issa* 8/10/2022  
DR. MOUSSA A. ISSA DATE  
LICENSE EXPIRES 11/30/2022  
SHEET RANGE 47-50

WHEELER AVENUE OVER I-80 (S.N. 099-8324)  
STA 18+81.17 TO STA 21+25.83  
IMPROVEMENTS BEGIN  
STA 17+65.00  
IMPROVEMENTS END  
STA 22+56.00

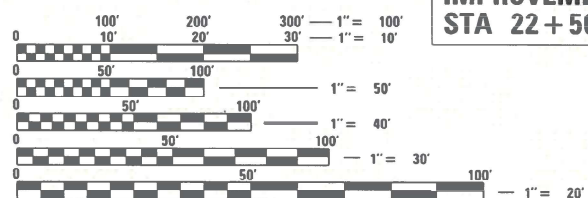

FULL SIZE PLANS HAVE BEEN PREPARED USING STANDARD ENGINEERING SCALES. REDUCED SIZED PLANS WILL NOT CONFORM TO STANDARD SCALES. IN MAKING MEASUREMENTS ON REDUCED PLANS, THE ABOVE SCALES MAY BE USED.

J.U.L.I.E.  
JOINT UTILITY LOCATION INFORMATION FOR EXCAVATION  
1-800-892-0123  
OR 811

MEADE ELECTRIC CO.  
DISTRICT ONE ELECTRICAL MAINTENANCE CONTRACTOR  
LOCATES IDOT ELECTRICAL EQUIPMENT AND UNDERGROUND CABLES  
773-287-7672

PROJECT ENGINEER: KEN PARK, PE  
PROJECT MANAGER: SULEYMAN TULGAR, PE

CONTRACT NO. 62R30

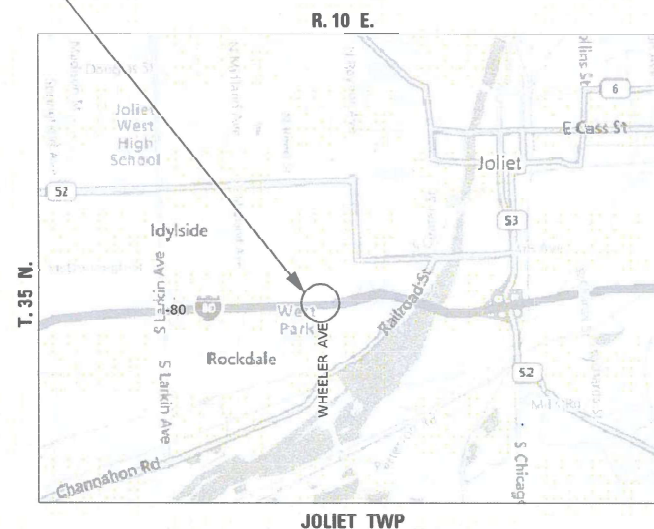

GROSS LENGTH = 491.00 FT. = 0.093 MILE  
NET LENGTH = 491.00 FT. = 0.093 MILE

LOCATION MAP NOT TO SCALE

STATE OF ILLINOIS  
DEPARTMENT OF TRANSPORTATION

SUBMITTED July 29 2022  
Jose Rios / OMB  
REGIONAL ENGINEER

\_\_\_\_\_  
20  
ENGINEER OF DESIGN AND ENVIRONMENT

\_\_\_\_\_  
20  
DIRECTOR OF HIGHWAYS PROJECT IMPLEMENTATION

PRINTED BY THE AUTHORITY OF THE STATE OF ILLINOIS

## INDEX OF SHEETS

1	COVER SHEET
2-3	INDEX OF SHEETS, HIGHWAY STANDARDS, GENERAL NOTES, AND COMMITMENTS
4-14	SUMMARY OF QUANTITIES
15-16	SCHEDULE OF QUANTITIES
17-20	TYPICAL SECTIONS
21	ALIGNMENT, TIES, AND BENCHMARKS
22	REMOVAL PLAN (WHEELER)
23	REMOVAL PLAN (I-80)
24	ROADWAY PLAN AND PROFILE (WHEELER)
25	ROADWAY PLAN (I-80)
26-31	SUGGESTED CONSTRUCTION STAGING AND TRAFFIC CONTROL PLANS
32-33	EROSION AND SEDIMENT CONTROL PLAN
34-36	DRAINAGE AND UTILITIES PLAN
37	GRADING PLAN
38-40	UTILITY LOCATION PLANS
41	INTERSECTION GRADING DETAILS
42-43	ROADWAY DETAILS
44-45	ADA DETAILS
46	PAVEMENT MARKING AND SIGNING DETAILS
47-50	BRIDGE MOUNT SIGN STRUCTURE DETAILS
51-57	LIGHTING PLANS
58-100	STRUCTURE 099-8324 PLANS
101-116	DISTRICT 1 STANDARD DETAILS
117-119	CITY OF JOLIET STANDARD DETAILS
120-121	CROSS SECTIONS - WHEELER AVE
122-130	CROSS SECTIONS - I-80

## HIGHWAY STANDARDS

000001-08	STANDARD SYMBOLS, ABBREVIATIONS AND PATTERNS
001001-02	AREAS OF REINFORCEMENT BARS
001006	DECIMAL OF AN INCH AND OF A FOOT
280001-07	TEMPORARY EROSION CONTROL SYSTEMS
420406	PAVEMENT CONNECTOR (HMA) FOR BRIDGE APPROACH SLABS
424001-11	PERPENDICULAR CURB RAMP FOR SIDEWALK
424006-05	DIAGONAL CURB RAMP FOR SIDEWALK
424021-06	DEPRESSED CORNER FOR SIDEWALK
515001-04	NAME PLATE FOR BRIDGES
542301-03	PRECAST REINFORCED CONCRETE FLARED END SECTION
602001-02	CATCH BASIN, TYPE A
602301-04	INLET, TYPE A
604001-05	FRAME AND LIDS TYPE 1
604051-04	FRAME AND GRATE TYPE 11
606001-08	CONCRETE CURB TYPE B & COMBINATION CONCRETE CURB & GUTTER
630001-12	STEEL PLATE BEAM GUARDRAIL
630201-07	PCC/HMA STABILIZATION AT STEEL PLATE BEAM GUARDRAIL
631011-10	TRAFFIC BARRIER TERMINAL, TYPE 2
631031-17	TRAFFIC BARRIER TERMINAL, TYPE 6
664001-02	CHAIN LINK FENCE
701001-02	OFF-RD OPERATIONS, 2L, 2W, MORE THAN 15' (4.5 m) AWAY
701006-05	OFF-RD OPERATIONS, 2L, 2W, 15' (4.5 m) TO 24" (600 mm) FROM PAVEMENT EDGE
701011-04	OFF-RD MOVING OPERATIONS, 2L, 2W, DAY ONLY
701301-04	LANE CLOSURE, 2L, 2W, SHORT TIME OPERATIONS
701400-11	APPROACH TO LANE CLOSURE, FREEWAY/EXPRESSWAY
701401-13	LANE CLOSURE, FREEWAY/EXPRESSWAY
701427-05	LANE CLOSURE, MULTILANE, INTERMITTENT OR MOVING OPER., FOR SPEEDS ≤ 40 MPH
701428-01	TRAFFIC CONTROL SETUP AND REMOVAL FREE/EXPRESSWAY
701501-06	URBAN LANE CLOSURE, 2, 2W, UNDIVIDED
701801-06	SIDEWALK, CORNER OR CROSSWALK CLOSURE
701901-08	TRAFFIC CONTROL DEVICES
704001-08	TEMPORARY CONCRETE BARRIER
720006-04	SIGN PANEL ERECTION DETAILS
720011-01	METAL POSTS FOR SIGNS, MARKERS & DELINEATORS
725001-01	OBJECT AND TERMINAL MARKERS
782006-01	GUARDRAIL AND BARRIER WALL REFLECTOR MOUNTING DETAILS

## DISTRICT STANDARDS

BD-07	DETAIL OF STORM SEWER CONNECTION TO EXISTING SEWER
BD-22	PAVEMENT PATCHING FOR HMA SURFACED PAVEMENT
BD-32	BUTT JOINT AND HMA TAPER DETAILS
BD-51	BENCHING DETAIL FOR EMBANKMENT WIDENING
TC-09	TRAFFIC CONTROL DETAILS FOR FREEWAY SINGLE & MULTI-LANE WEAVE
TC-10	TRAFFIC CONTROL AND PROTECTION FOR SIDE ROADS, INTERSECTIONS, AND DRIVEWAYS
TC-11	TYPICAL APPLICATIONS RAISED REFLECTIVE PAVEMENT MARKERS (SNOW-PLOW RESISTANT)
TC-12	MULTI-LANE FREEWAY PAVEMENT MARKING DETAILS
TC-13	DISTRICT ONE TYPICAL PAVEMENT MARKINGS
TC-16	SHORT TERM PAVEMENT MARKING LETTERS AND SYMBOLS
TC-17	TRAFFIC CONTROL DETAILS FOR FREEWAY SHOULDER CLOSURES AND PARTIAL RAMP CLOSURES
TC-18	FREEWAY/EXPRESSWAY SIGNING FOR FLAGGING OPERATIONS AT WORK ZONE OPENINGS ON FREEWAYS/EXPRESSWAYS
TC-21	DETOUR SIGNING FOR CLOSING STATE HIGHWAYS
TC-22	ARTERIAL ROAD INFORMATION SIGN
TC-25	TRAFFIC CONTROL DETAILS FOR FREEWAY CENTER LANE CLOSURE SHOULDER LANE

## COMMITMENTS

NONE.

MODEL: Default  
 FILE: I:\Data\pww\transys\scorp\pw\_bentley.ctb  
 PROJECT: TRANSYS\SCORP\_PW1\HOSTED\Documents\Projects\_2018\CH401\401.180022\02-Transys\scorp\CAD\02R30\Sheets\01-General\01-62R30-SHT-GENNOTES-01.dgn



USER NAME = mostafan  
 PLOT SCALE = 2,000' / in.  
 PLOT DATE = 8/10/2022

DESIGNED - NWM  
 DRAWN - KWM  
 CHECKED - SPF  
 DATE - 8/12/2022

REVISED -  
 REVISED -  
 REVISED -  
 REVISED -

STATE OF ILLINOIS  
 DEPARTMENT OF TRANSPORTATION

INDEX OF SHEETS, HIGHWAY STANDARDS, GENERAL NOTES,  
 DISTRICT 1 STANDARDS AND COMMITMENTS

SCALE: N.T.S. SHEET 1 OF 2 SHEETS STA. TO STA.

F.A.U. RTE.	SECTION	COUNTY	TOTAL SHEETS	SHEET NO.
340	FAI 80 21 STRUCTURE 9	WILL	130	2
CONTRACT NO. 62R30				
ILLINOIS FED. AID PROJECT				

**GENERAL NOTES**

1. THE THICKNESS OF HMA SHOWN ON THE PLANS IS THE NOMINAL THICKNESS. DEVIATIONS FROM THE NOMINAL THICKNESS WILL BE PERMITTED WHEN SUCH DEVIATIONS OCCUR DUE TO IRREGULARITIES IN THE EXISTING SURFACE OR BASE ON WHICH THE HMA IS PLACED.
2. SEEDING WILL NOT BE PERMITTED AT ANY TIME WHEN THE GROUND IS FROZEN, WET, OR IN AN UNTILLABLE CONDITION. LOCATIONS TO BE SEEDED WILL BE DETERMINED BY THE ENGINEER.
3. ANY REFERENCE TO A STANDARD IN THESE PLANS SHALL BE INTERPRETED TO MEAN THE EDITION AS INDICATED BY THE SUBNUMBER SHOWN IN THE LIST OF STANDARDS OR THE COPY INCLUDED IN THESE PLANS.
4. THE CONTRACTOR SHALL CALL "J.U.L.I.E." AT (800) 892-0123 OR 811 AT LEAST 72 HOURS PRIOR TO EXCAVATION TO DETERMINE WHICH BURIED ELECTRIC, TELEPHONE, AND GAS UTILITIES ARE IN THE AREA. 48 HOUR NOTIFICATION IS REQUIRED.
5. BEFORE BEGINNING ANY WORK, THE CONTRACTOR SHALL RETAIN AND RECORD FOR FUTURE REFERENCE, ALL EXISTING PAVEMENT MARKING LINES AND RAISED REFLECTIVE PAVEMENT MARKERS THAT CONFLICT WITH TEMPORARY MARKINGS, IN ORDER THAT THESE LOCATIONS CAN BE RE-ESTABLISHED FOR PROPOSED STRIPING AT THE COMPLETION OF THIS CONTRACT. EXACT LOCATIONS OF ALL PROPOSED PAVEMENT MARKINGS SHALL BE DIRECTED BY THE RESIDENT ENGINEER.
6. THE CONTRACTOR WILL NOT BE ABLE TO SET UP A YARD OR FIELD OFFICE ON STATE PROPERTY WITHOUT WRITTEN PERMISSION FROM THE DEPARTMENT.
7. IT SHALL BE THE CONTRACTORS RESPONSIBILITY TO VERIFY ALL DIMENSIONS AND CONDITIONS EXISTING IN THE FIELD PRIOR TO CONSTRUCTION AND ORDERING MATERIALS.
8. ALL DAMAGE TO EXISTING PAVEMENT MARKINGS OR RAISED REFLECTIVE PAVEMENT MARKERS OUTSIDE THE REMOVAL LINE SHOWN ON THE PLANS SHALL BE REPLACED AT NO ADDITIONAL COST TO THE DEPARTMENT.
9. THE CONTRACTOR SHALL COORDINATE CONSTRUCTION ACTIVITIES WITH AFFECTED UTILITY COMPANIES AND THE VILLAGE OF JOLIET.
10. THE CONTRACTOR SHALL USE CARE NEAR ANY AND ALL EXISTING ITEMS THAT WILL NOT BE REMOVED. ANY DAMAGE DONE TO EXISTING ITEMS BY THE CONTRACTOR SHALL BE REPAIRED OR REPLACED TO THE SATISFACTION OF THE ENGINEER AT THE CONTRACTOR'S OWN EXPENSE.
11. DO NOT SCALE PLANS FOR CONSTRUCTION DIMENSIONS.
12. DURING CONSTRUCTION OPERATIONS, IF ANY LOOSE MATERIAL IS DEPOSITED IN THE FLOW LINE OF DRAINAGE STRUCTURES SUCH THAT THE NATURAL FLOW OF WATER IS OBSTRUCTED, THE MATERIAL SHALL BE REMOVED AT THE CLOSE OF EACH WORKDAY. AT THE CONCLUSION OF CONSTRUCTION OPERATIONS, ALL UTILITY STRUCTURES SHALL BE FREE FROM DUST AND DEBRIS. THE WORK SPECIFIED ABOVE WILL NOT BE PAID SEPARATELY BUT SHALL BE INCLUDED IN THE COST OF THE CONTRACT.
13. PERMANENT PAVEMENT MARKINGS SHALL BE AS SPECIFIED IN THE PLANS AND SHALL BE PLACED IN ACCORDANCE WITH THE "DISTRICT ONE TYPICAL PAVEMENT MARKINGS" DETAIL TC-13 (DISTRICT ONE TYPICAL PAVEMENT MARKINGS).
14. THE SUBGRADE STABILITY SHALL BE VERIFIED BY PROOF ROLLING WITH A FULL LOADED TANDEM AXLE TRUCK.
15. THE CONTRACTOR SHALL ENSURE THAT EXPOSED AREAS HAVE ADEQUATE TEMPORARY SEEDING OR OTHER STABILIZATION PER THE NPDES 7 AND 14 DAY RULE. THIS WORK WILL NOT BE PAID FOR SEPARATELY, BUT SHALL BE INCLUDED IN THE COST OF THE CONTRACT.
16. BEFORE STARTING ANY EXCAVATION, THE CONTRACTOR SHALL CALL JULIE AT 811, OR (800) 892-0123 FOR FIELD LOCATIONS OF BURIED ELECTRIC, TELEPHONE AND GAS UTILITIES. 48 HOUR NOTIFICATION IS REQUIRED. WHEN WITHIN THE CITY OF CHICAGO'S CORPORATE LIMITS ALSO CALL 811 OR (312) 744-7000.
17. IDOT FACILITIES ARE NOT LOCATED BY JULIE OR DIGGER. IDOT ELECTRICAL FACILITIES INCLUDING ROADWAY LIGHTING, FIBER OPTIC, ITS EQUIPMENT, TRAFFIC SIGNAL AND PUMP STATION FACILITIES ARE LOCATED BY THE DEPARTMENT'S ELECTRICAL MAINTENANCE CONTRACTOR. AS OF THE LETTING DATE, CONTACT THE MEADE ELECTRIC COMPANY AT 773-287-7672.
18. THE CONTRACTOR SHALL BE REQUIRED TO PROVIDE ACCESS TO ABUTTING PROPERTY AT ALL TIMES DURING THE CONSTRUCTION OF THIS PROJECT.
19. TYPE I, TYPE II, AND TYPE III BARICADES SHALL BE WEIGHTED IN A MANNER APPROVED BY THE MANUFACTURER SO THEY ARE NOT MOVED BY TRAFFIC.
20. THE CONTRACTOR SHALL BE RESPONSIBLE FOR THE PROTECTION OF ALL UNDERGROUND OR SURFACE UTILITIES EVEN THOUGH THEY MAY NOT BE SHOWN IN THE PLANS. ANY UTILITY THAT IS DAMAGED DURING CONSTRUCTION SHALL BE REPAIRED OR REPLACED TO THE SATISFACTION OF THE ENGINEER. THIS WORK WILL BE AT THE CONTRACTORS EXPENSE.
21. THE CONTRACTOR SHALL COORDINATE WORK WITH UTILITIES IN ADVANCE OF WORKING IN THE VICINITY OF THEIR FACILITIES AND ALLOW SUFFICIENT TIME FOR THEM TO PREFORM ADJUSTMENTS TO THEIR FACILITIES IN ACCORDANCE WITH THE CONTRACTOR'S SCHEDULE. COORDINATION EFFORTS SHALL BE INCLUDED IN THE COST OF THE CONTRACT BID PRICE
22. THE DEPARTMENT HAS NOT OBTAINED ANY PERMITS FOR OFFSITE BORROW, WASTE, USE (BWU) AREAS. PRIOR TO WORKING IN BWU AREAS, IF THE CONTRACTOR CHOOSES TO USE ACTIVITIES REQUIRING PERMITS IT IS THE CONTRACTOR'S RESPONSIBILITY TO SECURE THE PROPER PERMITS. IN ADDITION TO THE BORROW REVIEW (BDE 2289) AND USE/WASTE REVIEW (BDE 2290) SUBMITTALS, THE CONTRACTOR SHALL SUBMIT AN EROSION AND SEDIMENT CONTROL (ESC) PLAN FOR EVERY BWU SITE TO THE DEPARTMENT FOR ACCEPTANCE. GUIDELINES FOR ACCEPTABLE BWU PRACTICES CAN BE FOUND IN SECTION II.G.1 AND 2 OF THE SWPPP. THE COST OF ALL MATERIALS AND LABOR NECESSARY TO COMPLY WITH THE ABOVE PROVISIONS TO PREPARE AND IMPLEMENT ESC PLANS WILL NOT BE PAID FOR SEPARATELY, BUT SHALL BE CONSIDERED AS INCLUDED IN THE UNIT BID PRICES OF THE CONTRACT AND NO ADDITIONAL COMPENSATION WILL BE ALLOWED.
23. THE PAVEMENT ELEVATIONS SHOWN ON THE PLANS ARE FINISHED GRADES OR SURFACE COURSE, UNLESS OTHERWISE NOTED.
24. THE COST OF FULL OR PARTIAL DEPTH SAW CUTS REQUIRED FOR REMOVAL ITEMS SHALL NOT BE PAID FOR SEPARATELY, BUT SHALL BE INCLUDED IN THE UNIT PRICE OF THE ITEM.

**GENERAL NOTES CONT.**

26. ANY AGGREGATE SUBGRADE IMPROVEMENT CONTAMINATED AND/OR DAMAGED BY THE CONTRACTOR'S VEHICLES AND/OR EQUIPMENTS IS TO BE REMOVED AND REPLACED AS DIRECT BY THE ENGINEER AT CONTRACTOR EXPENSE.
27. THE AGGREGATE GRADATION FOR THE AGGREGATE SUBGRADE IMPROVEMENT 12" LOWER LIFT SHALL BE CS 1 OR RR 1.
28. CONTRACTOR TO CONTACT THE ROADSIDE DEVELOPMENT UNIT AT (847) 705-4171 AT LEAST 2 WEEKS PRIOR TO FORESTRY WORK TO IDENTIFY AND MARK TREES TO SAVE WITHIN TREE REMOVAL AREAS.
29. THE CONTRACTOR SHALL CONTACT KALPANA KANNAN-HOSADURGA, THE DISTRICT ONE TRAFFIC CONTROL SUPERVISOR, AT KALPANA.KANNAN-HOSADURGA@ILLINOIS.GOV A MINIMUM OF 72 HOURS IN ADVANCE OF BEGINNING WORK.

MODEL: Default  
FILE: \\p01\msys\temp\p01\h05\TDRANSYS\CORP-PW1-HOSTED\Documents\proj\chic\_2018\CH401\401\_100022\02-TranSys\con\CD\02R30\Sheet01-Cover.dwg  
CD\02R30\Sheet01-Cover.dwg



USER NAME = mostafan	DESIGNED - NWM	REVISED -
	DRAWN - KWM	REVISED -
PLOT SCALE = 2,000' / in.	CHECKED - SPF	REVISED -
PLOT DATE = 8/10/2022	DATE - 8/12/2022	REVISED -

**STATE OF ILLINOIS  
DEPARTMENT OF TRANSPORTATION**

**INDEX OF SHEETS, HIGHWAY STANDARDS, GENERAL NOTES,  
DISTRICT 1 STANDARDS AND COMMITMENTS**

SCALE: N.T.S. SHEET 2 OF 2 SHEETS STA. TO STA.

F.A.U. RTE.	SECTION	COUNTY	TOTAL SHEETS	SHEET NO.
340	FAI 80 21 STRUCTURE 9	WILL	130	3
CONTRACT NO. 62R30				
ILLINOIS FED. AID PROJECT				

MODEL: Default  
 FILE: M:\a\c\p\trans\scorp\p1\h\hst\ed\Documents\proj\kls\_2018\CH401\401\_100027\02-TransSystems\CAD\2018\Sheet\03-Schedule\02R30-SHT-500.dgn

CODE NO.	ITEM	UNIT	TOTAL QUANTITY	CONSTRUCTION CODE		
				90% FEDERAL 10% STATE ROADWAY	90% FEDERAL 10% STATE BRIDGE	90% FEDERAL 10% STATE HIGHWAY LIGHTING
				0004	0010	0021
				URBAN	099-8324 RURAL	URBAN
20100500	TREE REMOVAL , ACRES	ACRE	0.50	0.50		
20101000	TEMPORARY FENCE	FOOT	340	340		
20101100	TREE TRUNK PROTECTION	EACH	10	10		
20101200	TREE ROOT PRUNING	EACH	5	5		
20101300	TREE PRUNING (1 TO 10 INCH DIAMETER)	EACH	5	5		
20200100	EARTH EXCAVATION	CU YD	2,155	2,155		
20201200	REMOVAL AND DISPOSAL OF UNSUITABLE MATERIAL	CU YD	385	385		
20800150	TRENCH BACKFILL	CU YD	64	64		
21001000	GEOTECHNICAL FABRIC FOR GROUND STABILIZATION	SQ YD	360	360		
21101505	TOPSOIL EXCAVATION AND PLACEMENT	CU YD	400	400		
21101625	TOPSOIL FURNISH AND PLACE, 6"	SQ YD	151	151		
25000210	SEEDING, CLASS 2A	ACRE	1	1		
25000312	SEEDING, CLASS 4A	ACRE	0.5	0.5		
25100115	MULCH, METHOD 2	ACRE	0.75	0.75		

\* SPECIALTY ITEM



USER NAME = mostafan	DESIGNED - NWM	REVISED -
PLOT SCALE = 2,000' / in.	DRAWN - KWM	REVISED -
PLOT DATE = 8/10/2022	CHECKED - SPF	REVISED -
	DATE - 8/12/2022	REVISED -

**STATE OF ILLINOIS  
DEPARTMENT OF TRANSPORTATION**

**WHEELER AVENUE OVER F.A.I. ROUTE 80  
SUMMARY OF QUANTITIES**

SCALE: N.T.S      SHEET 1 OF 11 SHEETS      STA.      TO STA.

F.A.U. RTE.	SECTION	COUNTY	TOTAL SHEETS	SHEET NO.
340	FBI 80 21 STRUCTURE 9	WILL	130	4
CONTRACT NO. 62R30				
ILLINOIS FED. AID PROJECT				

CODE NO.	ITEM	UNIT	TOTAL QUANTITY	CONSTRUCTION CODE		
				90% FEDERAL 10% STATE ROADWAY	90% FEDERAL 10% STATE BRIDGE	90% FEDERAL 10% STATE HIGHWAY LIGHTING
				0004	0010	0021
				URBAN	099-8324 RURAL	URBAN
25100630	EROSION CONTROL BLANKET	SQ YD	434	434		
25100635	HEAVY DUTY EROSION CONTROL BLANKET	SQ YD	2,313	2,313		
28000250	TEMPORARY EROSION CONTROL SEEDING	POUND	100	100		
28000400	PERIMETER EROSION BARRIER	FOOT	858	858		
28000510	INLET FILTERS	EACH	7	7		
28100101	STONE RIPRAP, CLASS A1	SQ YD	14	14		
28200200	FILTER FABRIC	SQ YD	14	14		
30300001	AGGREGATE SUBGRADE IMPROVEMENT	CU YD	120	120		
30300112	AGGREGATE SUBGRADE IMPROVEMENT 12"	SQ YD	1,573	1,573		
31101200	SUBBASE GRANULAR MATERIAL, TYPE B 4"	SQ YD	3,486	3,486		
31101400	SUBBASE GRANULAR MATERIAL, TYPE B 6"	SQ YD	275	275		
31102000	SUBBASE GRANULAR MATERIAL, TYPE C	CU YD	19	19		
40600290	BITUMINOUS MATERIALS (TACK COAT)	POUND	600	600		
40701826	HOT-MIX ASPHALT PAVEMENT (FULL-DEPTH), 7 1/4"	SQ YD	1334	1334		

\* SPECIALTY ITEM

MODEL: Default  
FILE: W:\a\p\1\2022\2022\TRANSPORTATION\Documents\Project\2018\CH401\401\_10002202\Task\System\CAD\2022\Sheet\03-5\Sheet\03-5.dwg  
D:\2022\2022\TRANSPORTATION\Documents\Project\2018\CH401\401\_10002202\Task\System\CAD\2022\Sheet\03-5\Sheet\03-5.dwg



USER NAME = mostafan	DESIGNED - NWM	REVISED -
	DRAWN - KWM	REVISED -
PLOT SCALE = 2,000' / in.	CHECKED - SPF	REVISED -
PLOT DATE = 8/10/2022	DATE - 8/12/2022	REVISED -

**STATE OF ILLINOIS  
DEPARTMENT OF TRANSPORTATION**

**WHEELER AVENUE OVER F.A.I. ROUTE 80  
SUMMARY OF QUANTITIES**

SCALE: N.T.S. SHEET 2 OF 11 SHEETS STA. TO STA.

F.A.U. RTE.	SECTION	COUNTY	TOTAL SHEETS	SHEET NO.
340	FBI 80 21 STRUCTURE 9	WILL	130	5
CONTRACT NO. 62R30				
ILLINOIS FED. AID PROJECT				

CODE NO.	ITEM	UNIT	TOTAL QUANTITY	CONSTRUCTION CODE		
				90% FEDERAL 10% STATE ROADWAY	90% FEDERAL 10% STATE BRIDGE	90% FEDERAL 10% STATE HIGHWAY LIGHTING
				0004	0010	0021
				URBAN	099-8324 RURAL	URBAN
42000070	PAVEMENT CONNECTOR (HMA) FOR BRIDGE APPROACH SLAB	SQ YD	96	96		
42300200	PORTLAND CEMENT CONCRETE DRIVEWAY PAVEMENT, 6 INCH	SQ YD	13	13		
42400200	PORTLAND CEMENT CONCRETE SIDEWALK 5 INCH	SQ FT	1,872	1,872		
42400800	DETECTABLE WARNINGS	SQ FT	80	80		
44000100	PAVEMENT REMOVAL	SQ YD	1,882	1,882		
44000200	DRIVEWAY PAVEMENT REMOVAL	SQ YD	25	25		
44000500	COMBINATION CURB AND GUTTER REMOVAL	FOOT	597	597		
44000600	SIDEWALK REMOVAL	SQ FT	2,251	2,251		
44001980	CONCRETE BARRIER REMOVAL	FOOT	47	47		
44004250	PAVED SHOULDER REMOVAL	SQ YD	3,042	3,042		
50100300	REMOVAL OF EXISTING STRUCTURES NO. 1	EACH	1		1	
50157300	PROTECTIVE SHIELD	SQ YD	1,570		1,570	
50200100	STRUCTURE EXCAVATION	CU YD	715		715	
50300225	CONCRETE STRUCTURES	CU YD	234.8		234.8	

\* SPECIALTY ITEM

MODEL: Default  
 FILE: W:\a\m\p\p\trans\scorp\p\1-hd\hds\ed\Documents\proj\kls\_2018\CH401\401\_100022\02-TransSystems\CAD\2020\Sheet\03-Schedule\0262R30-SHT-5000.dgn



USER NAME = mostafan	DESIGNED - NWM	REVISED -
PLOT SCALE = 2,000' / in.	DRAWN - KWM	REVISED -
PLOT DATE = 8/10/2022	CHECKED - SPF	REVISED -
	DATE - 8/12/2022	REVISED -

**STATE OF ILLINOIS  
 DEPARTMENT OF TRANSPORTATION**

**WHEELER AVENUE OVER F.A.I. ROUTE 80  
 SUMMARY OF QUANTITIES**

SCALE: N.T.S      SHEET 3 OF 11 SHEETS      STA.      TO STA.

F.A.U. RTE.	SECTION	COUNTY	TOTAL SHEETS	SHEET NO.
340	FBI 80 21 STRUCTURE 9	WILL	130	6
CONTRACT NO. 62R30				
ILLINOIS FED. AID PROJECT				

CODE NO.	ITEM	UNIT	TOTAL QUANTITY	CONSTRUCTION CODE		
				90% FEDERAL 10% STATE ROADWAY	90% FEDERAL 10% STATE BRIDGE	90% FEDERAL 10% STATE HIGHWAY LIGHTING
				0004	0010	0021
				URBAN	099-8324 RURAL	URBAN
50300255	CONCRETE SUPERSTRUCTURE	CU YD	554.9		554.9	
50300260	BRIDGE DECK GROOVING	SQ YD	1,367		1,367	
50300300	PROTECTIVE COAT	SQ YD	2,049	54	1,995	
50301350	CONCRETE SUPERSTRUCTURE (APPROACH SLAB)	CU YD	148.3		148.3	
50500105	FURNISHING AND ERECTING STRUCTURAL STEEL	L SUM	1		1	
50500505	STUD SHEAR CONNECTORS	EACH	4,998		4,998	
50800205	REINFORCEMENT BARS, EPOXY COATED	POUND	210,890		210,890	
50901739	BRIDGE FENCE RAILING, CURVED	FOOT	486		486	
51100100	SLOPE WALL 4 INCH	SQ YD	299		299	
51201900	FURNISHING STEEL PILES HP14X89	FOOT	789		789	
51202305	DRIVING PILES	FOOT	789		789	
51203900	TEST PILE STEEL HP14X89	EACH	3		3	
51204650	PILE SHOES	EACH	30		30	
51500100	NAME PLATES	EACH	1		1	

\* SPECIALTY ITEM

MODEL: Default  
 FILE: \\nafe\pww\transys\comp\pw\_bentley.com\TRANSYS\CORP\PW1\HOSTED\Documents\Projects\_2018\CH401\401180022\02-TransSystems\CAD\62R30\Sheets\03-Schedules\03-SHT-500.dgn



USER NAME = mostafan	DESIGNED - NWM	REVISED -
PLOT SCALE = 2.000" / in.	DRAWN - KWM	REVISED -
PLOT DATE = 8/10/2022	CHECKED - SPF	REVISED -
	DATE - 8/12/2022	REVISED -

**STATE OF ILLINOIS  
DEPARTMENT OF TRANSPORTATION**

**WHEELER AVENUE OVER F.A.I. ROUTE 80  
SUMMARY OF QUANTITIES**

SCALE: N.T.S      SHEET 4 OF 11 SHEETS      STA.      TO STA.

F.A.U. RTE.	SECTION	COUNTY	TOTAL SHEETS	SHEET NO.
340	FAI 80 21 STRUCTURE 9	WILL	130	7
			CONTRACT NO. 62R30	
ILLINOIS FED. AID PROJECT				

CODE NO.	ITEM	UNIT	TOTAL QUANTITY	CONSTRUCTION CODE		
				90% FEDERAL 10% STATE ROADWAY	90% FEDERAL 10% STATE BRIDGE	90% FEDERAL 10% STATE HIGHWAY LIGHTING
				0004	0010	0021
				URBAN	099-8324 RURAL	URBAN
52100520	ANCHOR BOLTS, 1"	EACH	28		28	
52100540	ANCHOR BOLTS, 1 1/2"	EACH	14		14	
542A1069	PIPE CULVERTS, CLASS A, TYPE 2 24"	FOOT	131	131		
54213447	END SECTIONS 12"	EACH	2	2		
550A0050	STORM SEWERS, CLASS A, TYPE 1 12"	FOOT	103	103		
550A0340	STORM SEWERS, CLASS A, TYPE 2 12"	FOOT	74	74		
55100500	STORM SEWER REMOVAL 12"	FOOT	294	294		
58600101	GRANULAR BACKFILL FOR STRUCTURES	CU YD	232.2		232.2	
58700300	CONCRETE SEALER	SQ FT	2,110		2,110	
59100100	GEOCOMPOSITE WALL DRAIN	SQ YD	124		124	
60146304	PIPE UNDERDRAINS FOR STRUCTURES 4"	FOOT	160		160	
60201105	CATCH BASINS, TYPE A, 4'-DIAMETER, TYPE 11 FRAME AND GRATE	EACH	2	2		
60218400	MANHOLES, TYPE A, 4'-DIAMETER, TYPE 1 FRAME, CLOSED LID	EACH	1	1		
60236800	INLETS, TYPE A, TYPE 11 FRAME AND GRATE	EACH	5	5		

\* SPECIALTY ITEM

MODEL Default  
 FILE Name: I:\projects\trans\scorp\p11\h05\TSD\Documents\proj\chgs\_2018\CH01\401100027\02-TrafficSystems\CAD\02\03\Sheet\03-Summary\03-Summary-SHT-500.dwg



USER NAME = mostafan	DESIGNED - NWM	REVISED -
PLOT SCALE = 2,000' / in.	DRAWN - KWM	REVISED -
PLOT DATE = 8/10/2022	CHECKED - SPF	REVISED -
	DATE - 8/12/2022	REVISED -

**STATE OF ILLINOIS  
DEPARTMENT OF TRANSPORTATION**

**WHEELER AVENUE OVER F.A.I. ROUTE 80  
SUMMARY OF QUANTITIES**

SCALE: N.T.S SHEET 5 OF 11 SHEETS STA. TO STA.

F.A.U. RTE.	SECTION	COUNTY	TOTAL SHEETS	SHEET NO.
340	FAI 80 21 STRUCTURE 9	WILL	130	8
CONTRACT NO. 62R30				
ILLINOIS FED. AID PROJECT				







MODEL Default  
FILE: \\msys\msys\comp\pbl\autlib\comp\TRANS\SCORP\DWG\2018\CH4001\100027\02-TRA\SYS\comp\CAD\02R30\SHEET\03-SL\sheet03.DWG(162830-SHT-500).dgn

CODE NO.	ITEM	UNIT	TOTAL QUANTITY	CONSTRUCTION CODE		
				90% FEDERAL 10% STATE ROADWAY	90% FEDERAL 10% STATE BRIDGE	90% FEDERAL 10% STATE HIGHWAY LIGHTING
				0004	0010	0021
				URBAN	099-8324	URBAN
					RURAL	
* 72400100	REMOVE SIGN PANEL ASSEMBLY - TYPE A	EACH	8	8		
* 72400200	REMOVE SIGN PANEL ASSEMBLY - TYPE B	EACH	2	2		
72501000	TERMINAL MARKER - DIRECT APPLIED	EACH	1	1		
* 72800100	TELESCOPING STEEL SIGN SUPPORT	FOOT	137.5	137.5		
* 73300400	OVERHEAD SIGN STRUCTURE - SPAN, TYPE IV-A (6'-0" X 8'-0")	FOOT	45		45	
* 78000100	THERMOPLASTIC PAVEMENT MARKING - LETTERS AND SYMBOLS	SQ FT	36.4	36.4		
* 78000200	THERMOPLASTIC PAVEMENT MARKING - LINE 4"	FOOT	5,348	5,348		
* 78000300	THERMOPLASTIC PAVEMENT MARKING - LINE 5"	FOOT	408	408		
* 78000400	THERMOPLASTIC PAVEMENT MARKING - LINE 6"	FOOT	144	144		
* 78000600	THERMOPLASTIC PAVEMENT MARKING - LINE 12"	FOOT	514	514		
* 78000650	THERMOPLASTIC PAVEMENT MARKING - LINE 24"	FOOT	87	87		
* 78009000	MODIFIED URETHANE PAVEMENT MARKING - LETTERS AND SYMBOLS	SQ FT	36.4	36.4		
* 78009004	MODIFIED URETHANE PAVEMENT MARKING - LINE 4"	FOOT	1,500	1,500		
* 78009006	MODIFIED URETHANE PAVEMENT MARKING - LINE 6"	FOOT	176	176		

\* SPECIALTY ITEM



USER NAME = mostafan	DESIGNED - NWM	REVISED -
	DRAWN - KWM	REVISED -
PLOT SCALE = 2,000' / in.	CHECKED - SPF	REVISED -
PLOT DATE = 8/10/2022	DATE - 8/12/2022	REVISED -

**STATE OF ILLINOIS  
DEPARTMENT OF TRANSPORTATION**

<b>WHEELER AVENUE OVER F.A.I. ROUTE 80 SUMMARY OF QUANTITIES</b>		F.A.U. RTE.	SECTION	COUNTY	TOTAL SHEETS	SHEET NO.
SCALE: N.T.S.	SHEET 8 OF 11 SHEETS	340	FBI 80 21 STRUCTURE 9	WILL	130	11
TO STA.		CONTRACT NO. 62R30				
		ILLINOIS FED. AID PROJECT				



MODEL Default  
 FILE: \\aecom\project\trans\scorp\p11\H05TED\Documents\proj\kls\_2018\CH401\401100027\02-TrafficSystems\CAD\02R30\Sheet\03-Schedule\03-Schedule.DWG

CODE NO.	ITEM	UNIT	TOTAL QUANTITY	CONSTRUCTION CODE		
				90% FEDERAL ROADWAY	90% FEDERAL BRIDGE	90% FEDERAL HIGHWAY LIGHTING
				10% STATE	10% STATE	10% STATE
				0004 URBAN	0010 099-8324	0021 URBAN
				RURAL		
X4023000	TEMPORARY ACCESS (ROAD)	EACH	4	4		
X6370050	CONCRETE BARRIER WALL (SPECIAL)	FOOT	49	49		
X6700407	ENGINEER'S FIELD OFFICE, TYPE A (D1)	CAL MO	18	18		
X7010216	TRAFFIC CONTROL AND PROTECTION, (SPECIAL)	L SUM	1	1		
X7011015	TRAFFIC CONTROL AND PROTECTION (EXPRESSWAYS)	L SUM	1	1		
Z0004510	HOT-MIX ASPHALT DRIVEWAY PAVEMENT, 3"	SQ YD	7	7		
Z0005216	HOT-MIX ASPHALT STABILIZATION 6" AT STEEL PLATE BEAM GUARD RAIL	SQ YD	67	67		
Z0013797	STABILIZED CONSTRUCTION ENTRANCE	SQ YD	700	700		
Z0013798	CONSTRUCTION LAYOUT	L SUM	1	1		
Z0022800	FENCE REMOVAL	FOOT	211	211		
Z0030850	TEMPORARY INFORMATION SIGNING	SQ FT	44	44		
Z0033028	MAINTENANCE OF LIGHTING SYSTEM	CAL MO	12		12	
Z0042300	PORTLAND CEMENT CONCRETE SIDEWALK CURB	FOOT	64	64		
Z0056648	STORM SEWERS, TYPE 1, WATER MAIN QUALITY PIPE, 12"	FOOT	53	53		

\* SPECIALTY ITEM



USER NAME = mostafan	DESIGNED - NWM	REVISED -
	DRAWN - KWM	REVISED -
PLOT SCALE = 2,000" / in.	CHECKED - SPF	REVISED -
PLOT DATE = 8/10/2022	DATE - 8/12/2022	REVISED -

STATE OF ILLINOIS  
DEPARTMENT OF TRANSPORTATION

WHEELER AVENUE OVER F.A.I. ROUTE 80  
SUMMARY OF QUANTITIES

SCALE: N.T.S    SHEET 10 OF 11 SHEETS    STA.    TO STA.

F.A.U. RTE.	SECTION	COUNTY	TOTAL SHEETS	SHEET NO.
340	FBI 80 21 STRUCTURE 9	WILL	130	13
CONTRACT NO. 62R30				
ILLINOIS FED. AID PROJECT				

CODE NO.	ITEM	UNIT	TOTAL QUANTITY	CONSTRUCTION CODE		
				90% FEDERAL 10% STATE ROADWAY	90% FEDERAL 10% STATE BRIDGE	90% FEDERAL 10% STATE HIGHWAY LIGHTING
				0004	0010	0021
				URBAN	099-8324 RURAL	URBAN
Z0056668	STORM SEWERS, TYPE 2, WATER MAIN QUALITY PIPE, 12"	FOOT	64	64		
Z0062456	TEMPORARY PAVEMENT	SQ YD	3,452	3,452		
Z0073510	TEMPORARY TRAFFIC SIGNAL TIMING	EACH	7	7		
∅ Z0076600	TRAINEES	HOURS	500	500		
∅ Z0076604	TRAINEES - TRAINING PROGRAM GRADUATE	HOURS	500	500		

\* SPECIALTY ITEM

MODEL: Default  
FILE NAME: p:\transys\scms-pw\batley.com\TRANSSYS\CORP-PW1\HOSTED\Documents\Projects\_2018\CH401\40118002\02-TransSystems\CAD\62R30\Sheets\03-Schedules\03-SHT-S00.dgn



USER NAME = mostafan	DESIGNED - NWM	REVISED -
	DRAWN - KWM	REVISED -
PLOT SCALE = 2.000" / in.	CHECKED - SPF	REVISED -
PLOT DATE = 8/10/2022	DATE -	REVISED -

STATE OF ILLINOIS  
DEPARTMENT OF TRANSPORTATION

WHEELER AVENUE OVER F.A.I. ROUTE 80  
SUMMARY OF QUANTITIES

SCALE: N.T.S. SHEET 11 OF 11 SHEETS STA. TO STA.

F.A.U. RTE.	SECTION	COUNTY	TOTAL SHEETS	SHEET NO.
340	FAI 80 21 STRUCTURE 9	WILL	130	14
CONTRACT NO. 62R30			∅ 0042	
ILLINOIS FED. AID PROJECT				

**EXISTING SIGNING SCHEDULE**

ALIGNMENT	STATION	RT/LT	TYPE	DESCRIPTION	W X H (in)		AREA (SQ FT)	72400100	72400200
					REMOVE SIGN PANEL ASSEMBLY - TYPE A (EACH)	REMOVE SIGN PANEL ASSEMBLY - TYPE B (EACH)			
WHEELER AVE .	18+41.54	LT	R2-1	SPEED LIMIT	24	30	5	1	
WHEELER AVE .	21+43.79	RT	R1-1	STOP	30	30	6.25	1	
			R1-3P	ALL WAY (PLAQUE)	18	6	0.75		
WHEELER AVE .	22+04.82	LT	R1-1	STOP	30	30	6.25	1	
			R1-3P	ALL WAY (PLAQUE)	18	6	0.75		
W PARK FRONT ST	05+54.81	RT	R1-1	STOP	30	30	6.25	1	
			R1-3P	ALL WAY (PLAQUE)	18	6	0.75		
W PARK FRONT ST	05+63.09	LT	R2-1	SPEED LIMIT	24	30	5	1	
W PARK FRONT ST	05+66.01	RT	R1-1	STOP	30	30	6.25	1	
W PARK AVE	10+57.10	RT	R2-1	SPEED LIMIT	24	30	5	1	
W PARK AVE	10+92.58	LT	R1-1	STOP	30	30	6.25	1	
			R1-3P	ALL WAY (PLAQUE)	18	6	0.75		
WHEELER AVE .	19+25.73	LT	D3-1	WHEELER AVE	96	24	16		1
WHEELER AVE .	20+87.17	RT	D3-1	WHEELER AVE	96	24	16		1
TOTAL :								8	2

**PROPOSED SIGNING SCHEDULE**

ALIGNMENT	STATION	RT/LT	TYPE	DESCRIPTION	W X H (in)		AREA (SQ FT)	72000100	72800100
					SIGN PANEL - TYPE 1 (SQ FT)	TELESCOPING STEEL SIGN SUPPORT (FOOT)			
WHEELER AVE .	18+00.00	RT	W3-1	ADVANCED TRAFFIC CONTROL	30	30	6.25	6.25	15.0
WHEELER AVE .	18+00.00	LT	R2-1	SPEED LIMIT	24	30	5	5.00	15.0
WHEELER AVE .	21+49.76	RT	R1-1	STOP	30	30	6.25	6.25	15.5
			R1-3P	ALL WAY (PLAQUE)	18	6	0.75	0.75	
WHEELER AVE .	22+17.90	LT	R1-1	STOP	30	30	6.25	6.25	15.5
			R1-3P	ALL WAY (PLAQUE)	18	6	0.75	0.75	
W PARK FRONT ST	05+58.56	LT	R2-1	SPEED LIMIT	24	30	5	5.00	15.0
W PARK FRONT ST	05+62.38	RT	R1-1	STOP	30	30	6.25	6.25	15.5
			R1-3P	ALL WAY (PLAQUE)	18	6	0.75	0.75	
W PARK FRONT ST	05+69.17	RT	R1-1	STOP	30	30	6.25	6.25	15.5
			R1-3P	ALL WAY (PLAQUE)	18	6	0.75	0.75	
W PARK AVE	10+54.80	RT	R2-1	SPEED LIMIT	24	30	5	5.00	15.0
W PARK AVE	10+86.01	LT	R1-1	STOP	30	30	6.25	6.25	15.5
			R1-3P	ALL WAY (PLAQUE)	18	6	0.75	0.75	
TOTAL :								56.25	137.5

MODEL: Default; FILE: W:\mstefan\project\trnsys\transys\scorp\pvt\hdstet\Documents\projctus\_2018\CH4001\4001100027\02-TRAFFIC\Drawings\CADD\230309Sheet\03-SC\scadd\03-SC\CH4001.dwg



USER NAME = mostafan  
 PLOT SCALE = 2,000' / in.  
 PLOT DATE = 8/10/2022

DESIGNED - NWM  
 DRAWN - KWM  
 CHECKED - SPF  
 DATE - 8/12/2022

REVISED -  
 REVISED -  
 REVISED -  
 REVISED -

**STATE OF ILLINOIS  
 DEPARTMENT OF TRANSPORTATION**

**WHEELER AVENUE OVER F.A.I. ROUTE 80  
 SCHEDULE OF QUANTITIES**

SCALE: N.T.S SHEET 1 OF 2 SHEETS STA. TO STA.

F.A.U. RTE.	SECTION	COUNTY	TOTAL SHEETS	SHEET NO.
340	FBI 80 21 STRUCTURE 9	WILL	130	15
CONTRACT NO. 62R30				
ILLINOIS			FED. AID PROJECT	

**EARTHWORK SCHEDULE – I-80**

I-80 EARTHWORK									
BEGIN STATION	END STATION	TOPSOIL EXCAVATION SEE NOTE 1 (CU YD)	EXCAVATED TOPSOIL AVAILABLE FOR REUSE (ADJ. FOR SHRINKAGE 15%) (CU YD)	TOPSOIL EXCAVATION AND PLACEMENT (CU YD)	TOPSOIL WASTE (+) OR SHORTAGE (-) SEE NOTES 2 AND 3 (CU YD)	EARTH EXCAVATION (CU YD)	EXCAVATION AVAILABLE FOR USE AS EMBANKMENT (ADJ. FOR SHRINKAGE 15%) (CU YD)	EMBANKMENT (CU YD)	EARTHWORK WASTE (+) OR SHORTAGE (-) (CU YD)
		A	B = 0.85 x A	C	D = A - B	F	G = 0.85 x F	H	I = G - H
633+00	633+50	10.7	9.1	4.0	+5.0	16.1	13.7	3.8	+10.0
633+50	634+00	11.3	9.6	5.5	+4.2	17.3	14.7	6.7	+8.0
634+00	634+50	12.0	10.2	5.8	+4.4	18.9	16.1	7.8	+8.3
634+50	635+00	12.7	10.8	6.1	+4.7	21.4	18.2	10.1	+8.1
635+00	635+50	13.2	11.2	6.2	+5.0	24.8	21.1	13.5	+7.6
635+50	636+00	15.1	12.8	6.8	+6.1	27.5	23.4	15.3	+8.1
636+00	636+50	19.3	16.4	8.2	+8.2	28.8	24.5	16.7	+7.8
636+50	637+00	22.1	18.8	8.4	+10.4	30.8	26.2	15.0	+11.1
637+00	637+50	22.0	18.7	7.3	+11.4	34.6	29.4	10.3	+19.1
637+50	638+00	22.4	19.0	7.5	+11.5	36.0	30.6	10.6	+20.1
638+00	638+50	24.1	20.5	8.8	+11.7	34.9	29.7	15.2	+14.5
638+50	639+00	26.0	22.1	9.4	+12.7	34.8	29.6	15.7	+13.9
639+00	639+50	15.4	13.1	5.9	+7.2	28.8	24.4	7.3	+17.1
639+50	640+00	4.3	3.6	2.4	+1.2	22.2	18.9	0.7	+18.2
640+00	640+50	29.4	25.0	2.5	+22.6	21.4	18.2	0.9	+17.3
640+50	641+00	54.6	46.4	2.3	+44.1	20.5	17.5	1.0	+16.4
641+00	641+50	54.9	46.7	2.2	+44.5	52.5	44.6	0.9	+43.8
641+50	642+00	54.8	46.6	1.9	+44.7	85.2	72.4	0.5	+71.9
642+00	642+50	55.3	47.0	2.4	+44.6	59.5	50.6	1.1	+49.5
642+50	643+00	35.0	29.8	4.0	+25.8	32.5	27.6	3.3	+24.4
643+00	643+50	13.5	11.5	5.1	+6.3	32.0	27.2	4.8	+22.5
643+50	644+00	12.0	10.2	5.0	+5.2	32.6	27.7	4.2	+23.5
644+00	10+00 R2	10.9	9.2	3.8	+5.4	26.4	22.4	3.1	+19.3
10+00 R2	10+50 R2	21.3	18.1	6.2	+11.9	38.1	32.4	6.4	+26.1
10+50 R2	11+00 R2	27.6	23.5	7.5	+15.9	40.9	34.8	9.8	+24.9
11+00 R2	11+50 R2	18.3	15.6	5.4	+10.2	30.2	25.7	6.9	+18.8
<b>TOTAL (I-80)</b>		<b>620</b>	<b>530</b>	<b>145</b>	<b>+385</b>	<b>850</b>	<b>725</b>	<b>195</b>	<b>+535</b>

**EARTHWORK SUMMARY OF QUANTITIES**

EARTHWORK SUMMARY					
PAY ITEM	DESCRIPTION	UNIT	I-80	WHEELER	TOTAL
20200100	EARTH EXCAVATION	CU YD	850	1305	2155
20201200	REMOVAL AND DISPOSAL OF UNSUITABLE MATERIAL	CU YD	385	0	385
21101505	TOPSOIL EXCAVATION AND PLACEMENT	CU YD	145	255	400
21101625	TOPSOIL FURNISH AND PLACE, 6"	SQ YD	0	151	151
66900200	NON-SPECIAL WASTE DISPOSAL	CU YD			620

**EARTHWORK SCHEDULE – WHEELER**

WHEELER EARTHWORK									
BEGIN STATION	END STATION	TOPSOIL EXCAVATION SEE NOTE 1 (CU YD)	EXCAVATED TOPSOIL AVAILABLE FOR REUSE (ADJ. FOR SHRINKAGE 15%) (CU YD)	TOPSOIL EXCAVATION AND PLACEMENT (CU YD)	TOPSOIL WASTE (+) OR SHORTAGE (-) SEE NOTES 2 AND 3 (CU YD)	EARTH EXCAVATION (CU YD)	EXCAVATION AVAILABLE FOR USE AS EMBANKMENT (ADJ. FOR SHRINKAGE 15%) (CU YD)	EMBANKMENT (CU YD)	EARTHWORK WASTE (+) OR SHORTAGE (-) (CU YD)
		A	B = 0.85 x A	C	D = A - B	F	G = 0.85 x F	H	I = G - H
17+65	17+75	2.0	1.7	1.2	+0.5	6.9	5.9	0.2	+5.7
17+75	18+00	6.1	5.2	4.1	+1.1	18.2	15.5	1.0	+14.5
18+00	18+25	4.8	4.1	2.7	+1.4	13.5	11.4	3.2	+8.2
18+25	18+50	28.6	24.3	19.2	+5.1	35.9	30.5	7.4	+23.1
18+50	18+75	59.2	50.3	52.4	-2.0	307.6	261.5	12.0	+249.5
18+75	19+00	69.5	59.1	72.1	-13.0	505.0	429.3	101.0	+328.3
19+00	19+25	52.1	44.3	45.4	-1.1	285.0	242.3	94.1	+148.2
<b>Bridge Omission</b>									
21+25	21+50	27.0	23.0	29.1	-6.2	17.0	14.4	51.3	-36.9
21+50	21+75	14.6	12.4	20.2	-7.8	22.6	19.2	6.7	+12.4
21+75	22+00	1.8	1.6	1.9	-0.3	23.9	20.3	6.1	+14.2
22+00	22+25	2.0	1.7	1.8	-0.1	34.2	29.1	0.2	+28.9
22+25	22+50	3.5	2.9	3.1	-0.2	32.7	27.8	0.2	+27.6
<b>TOTAL (WHEELER)</b>		<b>275</b>	<b>235</b>	<b>255</b>	<b>-25</b>	<b>1305</b>	<b>1110</b>	<b>285</b>	<b>+825</b>

**NOTES**

1. ASSUME 6" DEPTH OF EXISTING TOPSOIL TO BE STRIPPED
2. IF THE TOTAL VALUE FOR TOPSOIL EXCAVATION AND PLACEMENT IS + (WASTE) THE SURPLUS MATERIAL WILL BE PAID AS REMOVAL AND DISPOSAL OF UNSUITABLE MATERIAL (20201200)
3. IF THE TOTAL VALUE FOR TOPSOIL EXCAVATION AND PLACEMENT IS - (SHORTAGE) THE ADDITIONAL MATERIAL REQUIRED WILL BE PAID AS TOPSOIL FURNISH AND PLACE, 6" (21101625)
4. NO EARTHWORK IS ASSUMED TO BE BALANCED BETWEEN I-80 AND WHEELER AVE;  
I.E. EXCESS EXCAVATION FROM WHEELER IS NOT ASSUMED TO BE USED AS EMBANKMENT ON I-80.
5. NON-SPECIAL WASTE IS PROVIDED AS A PROVISIONAL QUANTITY.

MODEL: Default  
 FILE: \\msys\comps\comp\hantley\com\TRANS\SCORP-PW1-HOSTED\Documents\proj\kls\_2018\CH400\401\1002\02-Tra\sys\com\CAD\02R30\Sheet\03-Sched\05-I-80-Sched.dgn



USER NAME = mostafan  
 PLOT SCALE = 2,000' / in.  
 PLOT DATE = 8/10/2022

DESIGNED - NWM  
 DRAWN - KWM  
 CHECKED - SPF  
 DATE - 8/12/2022

REVISED -  
 REVISED -  
 REVISED -  
 REVISED -

**STATE OF ILLINOIS  
 DEPARTMENT OF TRANSPORTATION**

**WHEELER AVENUE OVER F.A.I. ROUTE 80  
 EARTHWORK SCHEDULES**

SCALE: N.T.S    SHEET 2 OF 2 SHEETS    STA.    TO STA.

F.A.U. RTE.	SECTION	COUNTY	TOTAL SHEETS	SHEET NO.
340	FAI 80 21 STRUCTURE 9	WILL	130	16
CONTRACT NO. 62R30				
ILLINOIS FED. AID PROJECT				







**LEGEND**

- A EXISTING PAVEMENT
- B EXISTING SHOULDER
- 1 TEMPORARY PAVEMENT  
SEE MAINTENANCE OF TRAFFIC PLANS FOR LOCATIONS AND WIDTHS
- 2 TOPSOIL FURNISH AND PLACE, 6"
- 3 TEMPORARY CONCRETE BARRIER (TO REMAIN PERMANENTLY)
- 4 SUBBASE GRANULAR MATERIAL, TYPE B 6"

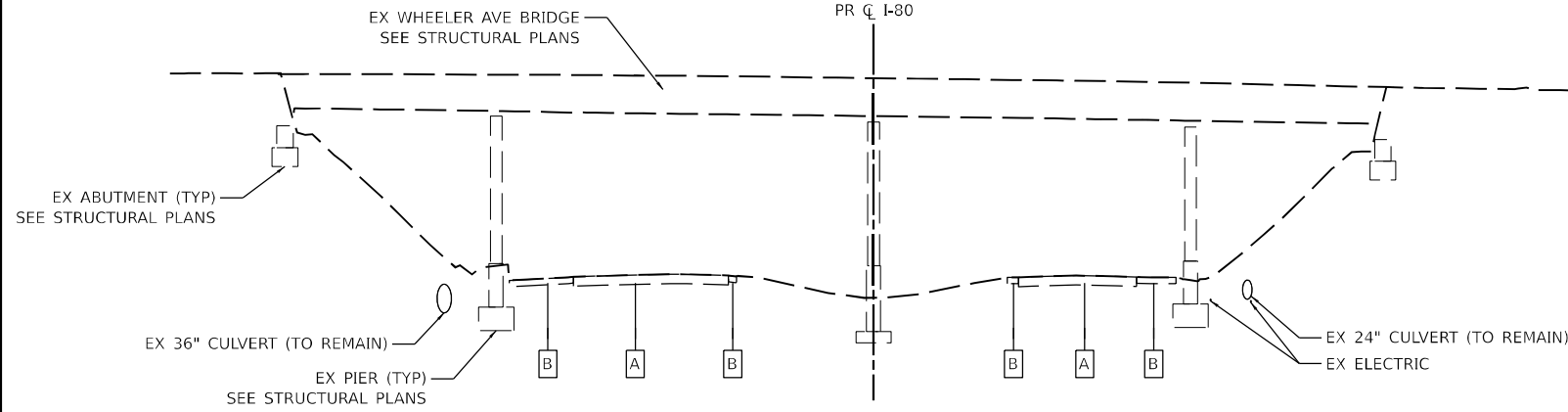

**EXISTING TYPICAL SECTION**  
I-80  
LOOKING EAST  
STA 641+38 TO STA 641+95

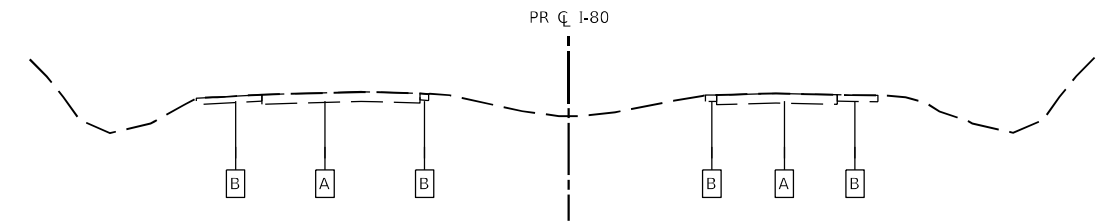

**EXISTING TYPICAL SECTION**  
I-80  
LOOKING EAST  
STA 633+00.00 TO STA 641+38  
STA 641+95 TO STA 13+00.00 R2

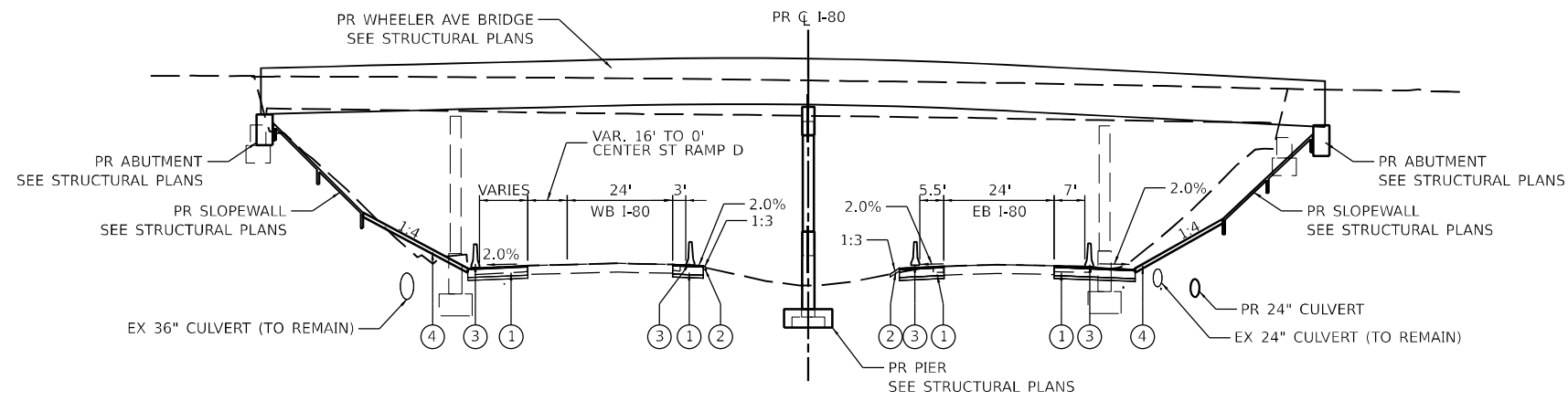

**PROPOSED TYPICAL SECTION**  
I-80  
LOOKING EAST  
STA 641+38 TO STA 641+95

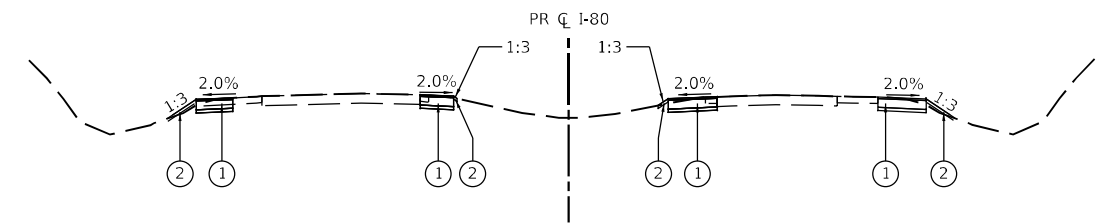

**PROPOSED TYPICAL SECTION**  
I-80  
LOOKING EAST  
STA 633+00.00 TO STA 641+38  
STA 641+95 TO STA 13+00.00 R2

MODEL Default  
 FILE: M:\62R30\62R30-TYPICAL\62R30-STRUC\62R30-SHEET\02-TP\_Sect\02R30-SHT-TYP-SEC-02.dwg  
 PROJECT: 62R30 - WHEELER AVENUE OVER F.A.I. ROUTE 80  
 DATE: 8/10/2022



USER NAME = mostafan  
 PLOT SCALE = 40,000' / in.  
 PLOT DATE = 8/10/2022

DESIGNED -	NWM	REVISED -
DRAWN -	KWM	REVISED -
CHECKED -	SPF	REVISED -
DATE -	8/12/2022	REVISED -

**STATE OF ILLINOIS  
DEPARTMENT OF TRANSPORTATION**

**WHEELER AVENUE OVER F.A.I. ROUTE 80  
TYPICAL SECTIONS**

SCALE: N.T.S.      SHEET 3 OF 4 SHEETS      STA.                      TO STA.

F.A.U. RTE.	SECTION	COUNTY	TOTAL SHEETS	SHEET NO.
340	FAL 80 21 STRUCTURE 9	WILL	130	19
CONTRACT NO. 62R30				

ILLINOIS FED. AID PROJECT

### HOT-MIX ASPHALT MIXTURE REQUIREMENTS

HOT-MIX ASPHALT MIXTURE REQUIREMENTS		
MIXTURE TYPES	AIR Voids @ NDES	QUALITY MANAGEMENT PROGRAM (QMP)
HOT-MIX ASPHALT PAVEMENT (FULL-DEPTH), 7 1/4"		
HOT-MIX ASPHALT SURFACE COURSE, IL-9.5, MIX "D", N70, 2"	4% @ 70 GYR.	QC/QA
HOT-MIX ASPHALT BINDER COURSE, IL-19.0, N70, 5 1/4"	4% @ 70 GYR.	QC/QA
HOT-MIX ASPHALT DRIVEWAY PAVEMENT, 3"		
HOT-MIX ASPHALT SURFACE COURSE, IL-9.5, MIX "D", N50, 3" (IN 2 LIFTS)	4% @ 50 GYR.	QC/QA
HOT-MIX ASPHALT STABILIZATION 6" AT STEEL PLATE BEAM GUARD RAIL		
HOT-MIX ASPHALT BINDER COURSE, IL-19.0, N50, 6"	4% @ 50 GYR.	QC/QA
PAVEMENT CONNECTOR (HMA) FOR BRIDGE APPROACH SLAB		
HOT-MIX ASPHALT SURFACE COURSE, IL-9.5, MIX "D", N70, 2"	4% @ 70 GYR.	QC/QA
HOT-MIX ASPHALT BINDER COURSE, IL-19.0, N70, 13"	4% @ 70 GYR.	QC/QA
TEMPORARY PAVEMENT		
HOT-MIX ASPHALT SURFACE COURSE, IL-9.5, MIX "D", N70, 2"	4% @ 70 GYR.	QC/QA
HOT-MIX ASPHALT BINDER COURSE, IL-19.0, N70, 11"	4% @ 70 GYR.	QC/QA

QMP DESIGNATION: QUALITY CONTROL/QUALITY ASSURANCE (QC/QA); QUALITY CONTROL FOR PERFORMANCE (QCP)

### MIXTURE TABLE NOTES

1. THE UNIT WEIGHT USED TO CALCULATE ALL HOT-MIX ASPHALT SURFACE MIXTURE QUANTITIES IS 112 LBS/SY/IN.
2. THE "AC TYPE" FOR POLYMERIZED HMA MIXES SHALL BE "SBS/SBR PG 76-22" AND FOR NON-POLYMERIZED HMA THE "AC TYPE" SHALL BE "PG 64-22", UNLESS MODIFIED BY RECLAIMED MATERIALS SPECIFICATIONS.

### SUBGRADE TREATMENT DETAIL

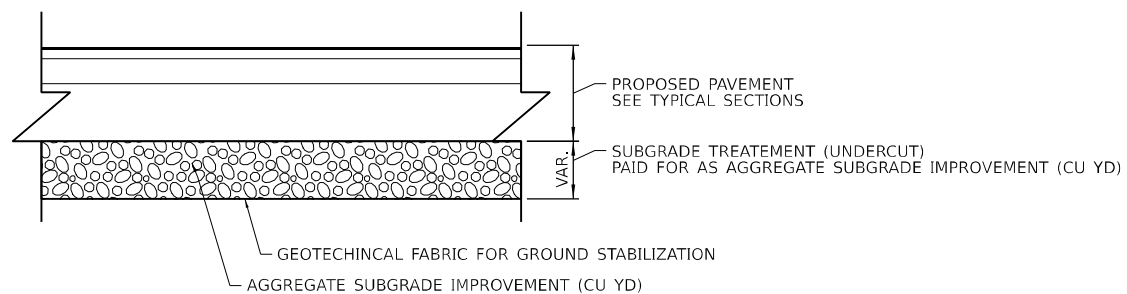

### SUBGRADE TREATMENT GENERAL NOTES

1. APPROVAL BY THE ENGINEER IS REQUIRED BEFORE PROCEEDING WITH SUBGRADE TREATMENT (UNDERCUT). NO PAYMENT WILL BE MADE FOR LOCATIONS TREATED WITHOUT THE ENGINEER'S PRIOR APPROVAL.
2. SUBGRADE TREATMENT (UNDERCUT) LOCATIONS AND DEPTH SHALL BE DETERMINED IN THE FIELD. REFER TO THE BDE SPECIAL PROVISIONS FOR ADDITIONAL INFORMATION.

### TEMPORARY PAVEMENT DETAILS

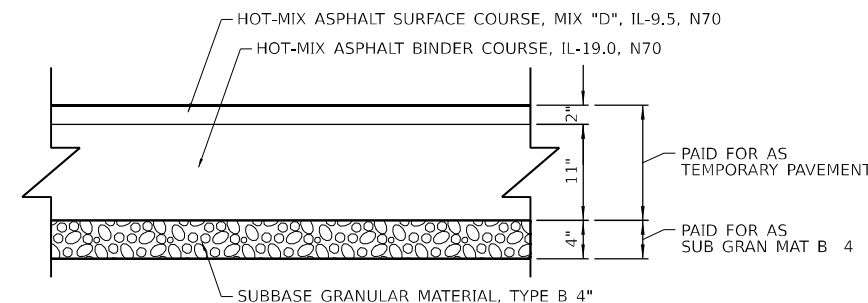

### OPTION 1: TEMPORARY HMA PAVEMENT

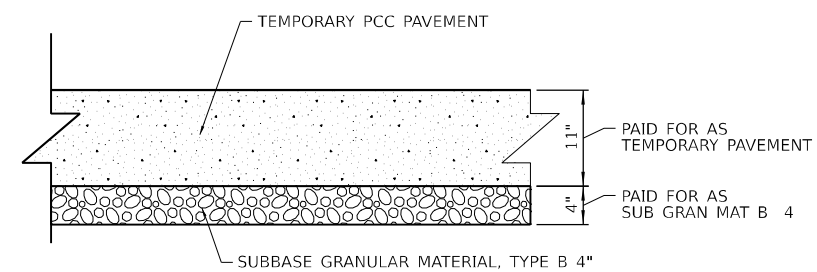

### OPTION 2: TEMPORARY PCC PAVEMENT

### TEMPORARY PAVEMENT GENERAL NOTES

1. THE CONTRACTOR SHALL HAVE THE OPTION OF CONSTRUCTING EITHER MATERIAL TYPE IF BOTH PORTLAND CEMENT CONCRETE AND HMA ARE SHOWN IN THE PLANS. FOR QUANTITY ESTIMATION PURPOSES, EXCAVATION QUANTITIES SHOULD BE ESTIMATED ASSUMING THE THICKER DESIGN IF BOTH OPTIONS ARE SHOWN IN THE PLANS.
2. PC CONCRETE TEMPORARY PAVEMENT SHALL CONSIST OF CLASS PV CONCRETE MEETING THE REQUIREMENTS OF ART. 1020 OF THE STANDARD SPECIFICATIONS. TEMPORARY PCC PAVEMENT DOES NOT REQUIRE DOWEL BARS.

MODEL: Defaul... FILE: W:\proj\m\systems\temp\pav\h\... 2018\CH4401\4401\100022\02-Tra\m\systems\com\CAD\02\02\03\Sheet\02-Tra\_Sec\ID\02R30-SHT-TYP-SEC-C4.dwg



USER NAME = mostafan	DESIGNED - NWM	REVISED -
PLOT SCALE = 20,000' / in.	DRAWN - KWM	REVISED -
PLOT DATE = 8/10/2022	CHECKED - SPF	REVISED -
	DATE - 8/12/2022	REVISED -

**STATE OF ILLINOIS  
DEPARTMENT OF TRANSPORTATION**

**WHEELER AVENUE OVER F.A.I. ROUTE 80  
TYPICAL SECTIONS**

SCALE: N.T.S. SHEET 4 OF 4 SHEETS STA. TO STA.

F.A.U. RTE.	SECTION	COUNTY	TOTAL SHEETS	SHEET NO.
340	FBI 80 21 STRUCTURE 9	WILL	130	20

CONTRACT NO. 62R30

ILLINOIS FED. AID PROJECT

CONTROL POINTS				
CONTROL POINT #	NORTHING	EASTING	ELEVATION	DESCRIPTION
199	1764712.578	1046445.728	612.724	FOUND MAG NAIL
200	1764732.059	1046947.633	617.906	FOUND MAG NAIL
201	1764871.307	1046944.538	617.653	FOUND MAG NAIL
202	1764837.277	1046443.936	612.780	FOUND MAG NAIL
1602	1764929.991	1046763.206	637.389	FOUND MAG NAIL
1603	1764635.879	1046770.566	635.669	FOUND MAG NAIL

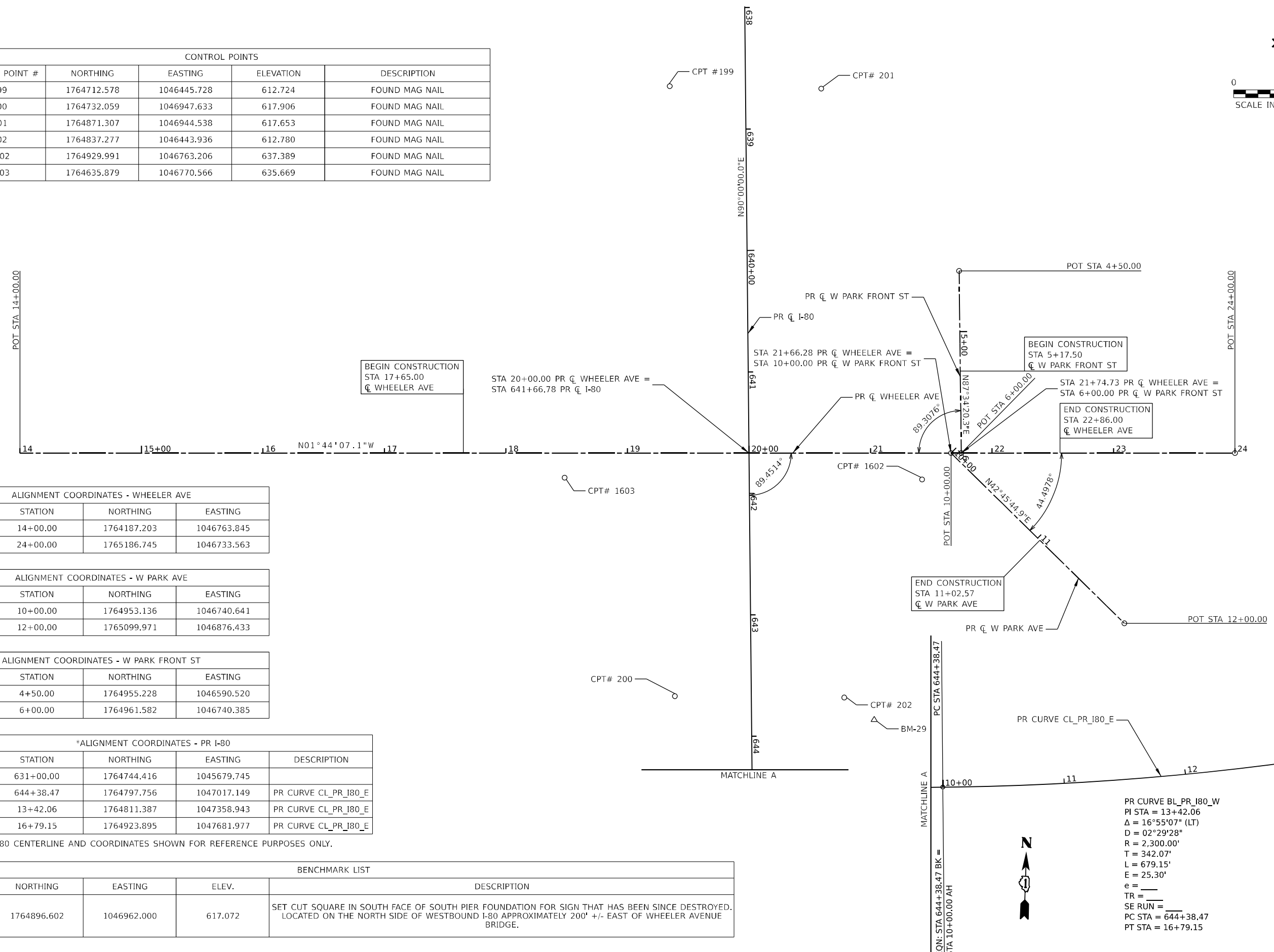
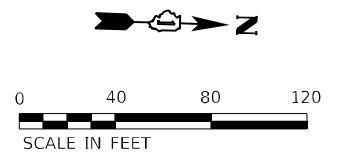

ALIGNMENT COORDINATES - WHEELER AVE			
POINT	STATION	NORTHING	EASTING
POT	14+00.00	1764187.203	1046763.845
POT	24+00.00	1765186.745	1046733.563

ALIGNMENT COORDINATES - W PARK AVE			
POINT	STATION	NORTHING	EASTING
POT	10+00.00	1764953.136	1046740.641
POT	12+00.00	1765099.971	1046876.433

ALIGNMENT COORDINATES - W PARK FRONT ST			
POINT	STATION	NORTHING	EASTING
POT	4+50.00	1764955.228	1046590.520
POT	6+00.00	1764961.582	1046740.385

*ALIGNMENT COORDINATES - PR I-80				
POINT	STATION	NORTHING	EASTING	DESCRIPTION
POT	631+00.00	1764744.416	1045679.745	
PC	644+38.47	1764797.756	1047017.149	PR CURVE CL_PR_I80_E
PI	13+42.06	1764811.387	1047358.943	PR CURVE CL_PR_I80_E
PT	16+79.15	1764923.895	1047681.977	PR CURVE CL_PR_I80_E

\*PARTIAL PR I-80 CENTERLINE AND COORDINATES SHOWN FOR REFERENCE PURPOSES ONLY.

BENCHMARK LIST				
BM #	NORTHING	EASTING	ELEV.	DESCRIPTION
BM-29	1764896.602	1046962.000	617.072	SET CUT SQUARE IN SOUTH FACE OF SOUTH PIER FOUNDATION FOR SIGN THAT HAS BEEN SINCE DESTROYED. LOCATED ON THE NORTH SIDE OF WESTBOUND I-80 APPROXIMATELY 200' +/- EAST OF WHEELER AVENUE BRIDGE.



USER NAME = mostafan	DESIGNED - NWM	REVISED -
PLOT SCALE = 80,000' / in.	DRAWN - KWM	REVISED -
PLOT DATE = 8/10/2022	CHECKED - SPF	REVISED -
	DATE - 8/12/2022	REVISED -

**STATE OF ILLINOIS  
DEPARTMENT OF TRANSPORTATION**

<b>WHEELER AVENUE OVER F.A.I. ROUTE 80 ALIGNMENT, TIES, AND BENCHMARKS</b>	
SCALE: 1" = 40'	SHEET 1 OF 1 SHEETS
STA. 14+00	TO STA. 24+00

F.A.U. RTE.	SECTION	COUNTY	TOTAL SHEETS	SHEET NO.
340	FBI 80 21 STRUCTURE 9	WILL	130	21
CONTRACT NO. 62R30				
ILLINOIS FED. AID PROJECT				

MODEL: Default  
 FILE: WHEELER\_AVE\_Plan\_14+00.dwg  
 PLOT DATE: 8/10/2022  
 PLOT SCALE: 80,000' / in.  
 PLOT DATE: 8/10/2022  
 PROJECT: I-80 OVER WHEELER AVE  
 SHEET: 21 OF 130  
 CONTRACT: 62R30

**REMOVAL LEGEND**

	PAVEMENT REMOVAL		LINEAR REMOVAL
	PAVED SHOULDER REMOVAL		TREE TRUNK PROTECTION
	SIDEWALK REMOVAL		TREE REMOVAL, ACRES
	DRIVEWAY PAVEMENT REMOVAL		

**NOTES**

- SEE SHEET 23 FOR REMOVAL INFORMATION ALONG I-80.
- STATIONS PROVIDED REFER TO PR  $\text{\textcircled{C}}$  WHEELER UNLESS OTHERWISE NOTED. SUFFIX (PF) REFERS TO  $\text{\textcircled{C}}$  W PARK FRONT ST. (PA) REFERS TO  $\text{\textcircled{C}}$  W PARK AVE.

**TREE REMOVAL NOTES**

- TREES IDENTIFIED FOR REMOVAL WILL BE CUT OFF AT GROUND LEVEL AS PART OF CONTRACT 62U34 - ADVANCED TREE REMOVAL CONTRACT.
- NO TREE REMOVAL OR TREE CLEARING SHALL OCCUR FROM APRIL 1 TO SEPTEMBER 30 DUE TO IDOT'S COMMITMENT TO PROTECT THE NORTHERN LONG-EARED BAT (NLEB). THE REMOVAL OF STUMPS IS EXEMPT FROM THE RESTRICTION DATES.

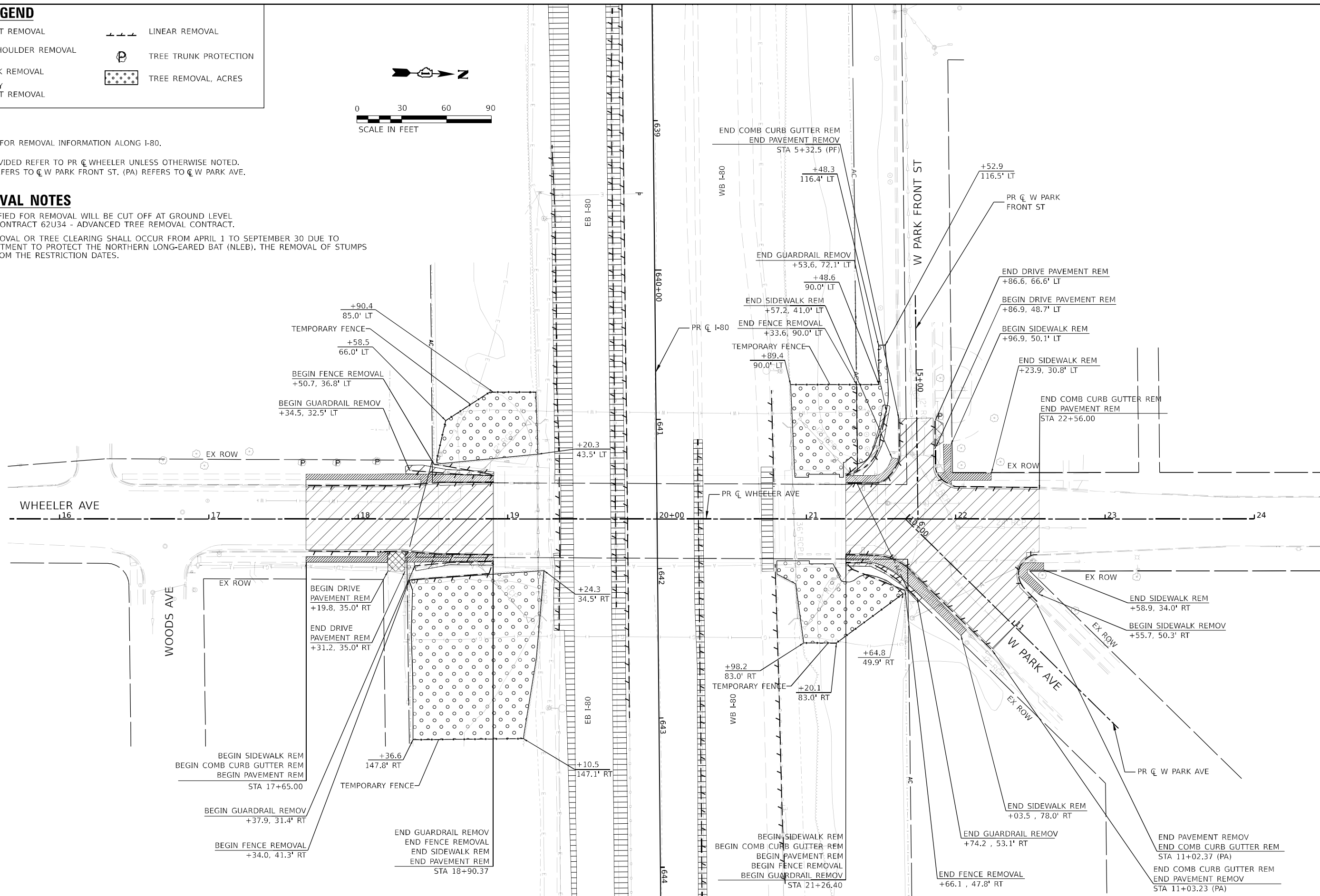
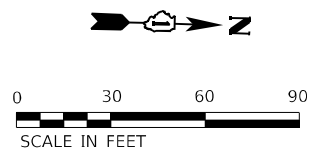

MODEL: Defaul...  
 FILE NAME: pz:\itranstmsystems\pww\ent\ev.com\TRANSSCOPR\PNV\HOSTED\Documents\projects\2018\CH401\401\_18002702-TransSystems\CAD\62U34\62U34\Sheet\05-ROAD\_Remov\1678365\SHIT-REMOV.dgn









USER NAME = mostafan	DESIGNED - NWM	REVISED -
PLOT SCALE = 61.089' / in.	DRAWN - KWM	REVISED -
PLOT DATE = 9/28/2022	CHECKED - SPF	REVISED -
	DATE - 8/12/2022	REVISED -

**STATE OF ILLINOIS  
DEPARTMENT OF TRANSPORTATION**

<b>WHEELER AVENUE OVER F.A.I. ROUTE 80 REMOVAL PLAN - WHEELER AVENUE</b>	
SCALE: 1"=30'	SHEET 1 OF 2 SHEETS STA. 16+00 TO STA. 24+00

F.A.I. RTE.	SECTION	COUNTY	TOTAL SHEETS	SHEET NO.
340	FAI 80 21 STRUCTURE 9	WILL	130	22
CONTRACT NO. 62R30			ILLINOIS FED. AID PROJECT	

**REMOVAL LEGEND**

-  PAVEMENT REMOVAL
-  PAVED SHOULDER REMOVAL
-  SIDEWALK REMOVAL
-  DRIVEWAY PAVEMENT REMOVAL
-  LINEAR REMOVAL
-  TREE TRUNK PROTECTION
-  TREE REMOVAL, ACRES

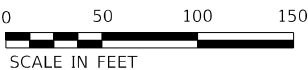

**NOTES**

- 1. SEE SHEET 22 FOR REMOVAL INFORMATION ALONG WHEELER AVE.
- 2. ALL STATIONING REFERS TO PR C I-80 UNLESS OTHERWISE NOTED.
- 3. SEE MAINTENANCE OF TRAFFIC PLANS FOR TEMPORARY PAVEMENT LOCATIONS.

**TREE REMOVAL NOTES**

- 1. TREES IDENTIFIED FOR REMOVAL WILL BE CUT OFF AT GROUND LEVEL AS PART OF CONTRACT 62U34 - ADVANCED TREE REMOVAL CONTRACT.
- 2. NO TREE REMOVAL OR TREE CLEARING SHALL OCCUR FROM APRIL 1 TO SEPTEMBER 30 DUE TO IDOT'S COMMITMENT TO PROTECT THE NORTHERN LONG-EARED BAT (NLEB). THE REMOVAL OF STUMPS IS EXEMPT FROM THE RESTRICTION DATES.

MODEL Defaul  
 FILE \\wheeler-pw-1\pww\systems\temp\pww-bentley.com\TRANSYS\SCORP-PW-1\HOSTED\Documents\Projects\2018\CH4014401.1\002702-TrafficSystems\CD\62R30\SHEET\05-REMOVAL-02.dwg

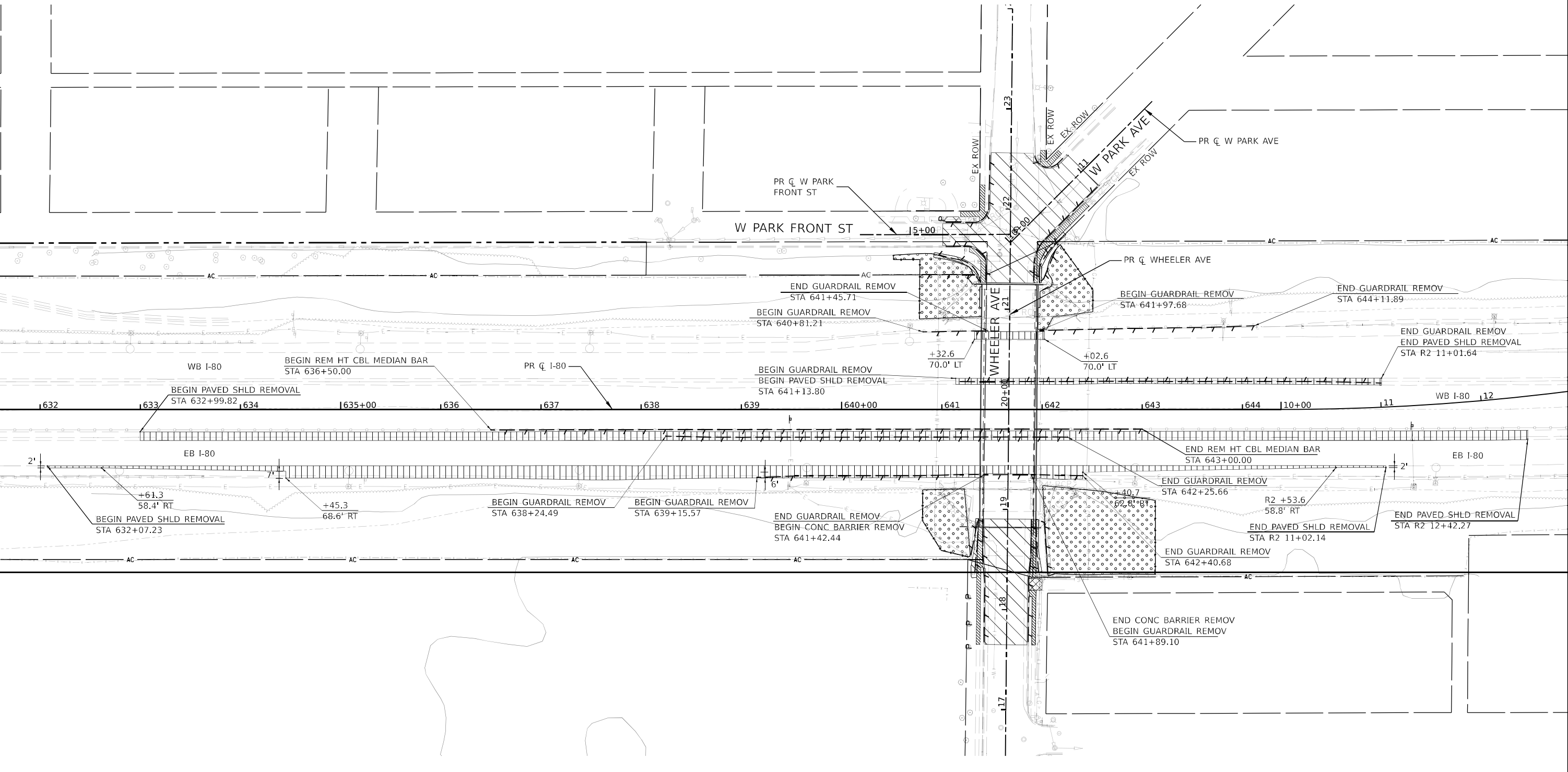

USER NAME = mostafan	DESIGNED - NWM	REVISED -
DRAWN - KWM	REVISED -	
PLLOT SCALE = 100,000' / in.	CHECKED - SPF	REVISED -
PLLOT DATE = 9/29/2022	DATE - 8/12/2022	REVISED -

STATE OF ILLINOIS  
DEPARTMENT OF TRANSPORTATION

WHEELER AVENUE OVER F.A.I. ROUTE 80  
REMOVAL PLAN - I-80

SCALE: 1"=50' SHEET 2 OF 2 SHEETS STA. 631+50 TO STA. 12+90

F.A.U. RTE.	SECTION	COUNTY	TOTAL SHEETS	SHEET NO.
340	FBI 80 21 STRUCTURE 9	WILL	130	23
CONTRACT NO. 62R30			ILLINOIS FED. AID PROJECT	

**GENERAL NOTES**

- STATIONS PROVIDED REFER TO PR  $\bar{C}$  WHEELER UNLESS OTHERWISE NOTED. SUFFIX (PF) REFERS TO  $\bar{C}$  W PARK FRONT ST. (PA) REFERS TO  $\bar{C}$  W PARK AVE.
- PREFIXES PC, PT, AND PI REFER TO POINTS OF CURVATURE, TANGENCY, AND INTERSECTION, RESPECTIVELY.
- SEE ADA DETAILS FOR ADDITIONAL SIDEWALK INFORMATION.
- SEE INTERSECTION GRADING DETAILS FOR ADDITIONAL INFORMATION.

DATE	
BY	
PLAN	SUBMITTED
	PLOTTED
	ALIGNMENT CHECKED
	NOTE BOOK NO.
	FILE NAME

DATE	
BY	
PROFILE	SUBMITTED
	PLOTTED
	GRADES CHECKED
	NOTE BOOK NO.
	STRUCTURE NOTATION CHKD

MODEL: Default  
 FILE NAME: p:\p\transys\paw\1051\ED\Documents\Projects\_2018\10401401\180022\02-Transys\CONP-AW-1051\ED\Documents\Projects\_2018\10401401\180022\02-Transys\CD\242424\Sheets\06-ROAD\_Plan\_Plan\_180242424-180242424.dwg

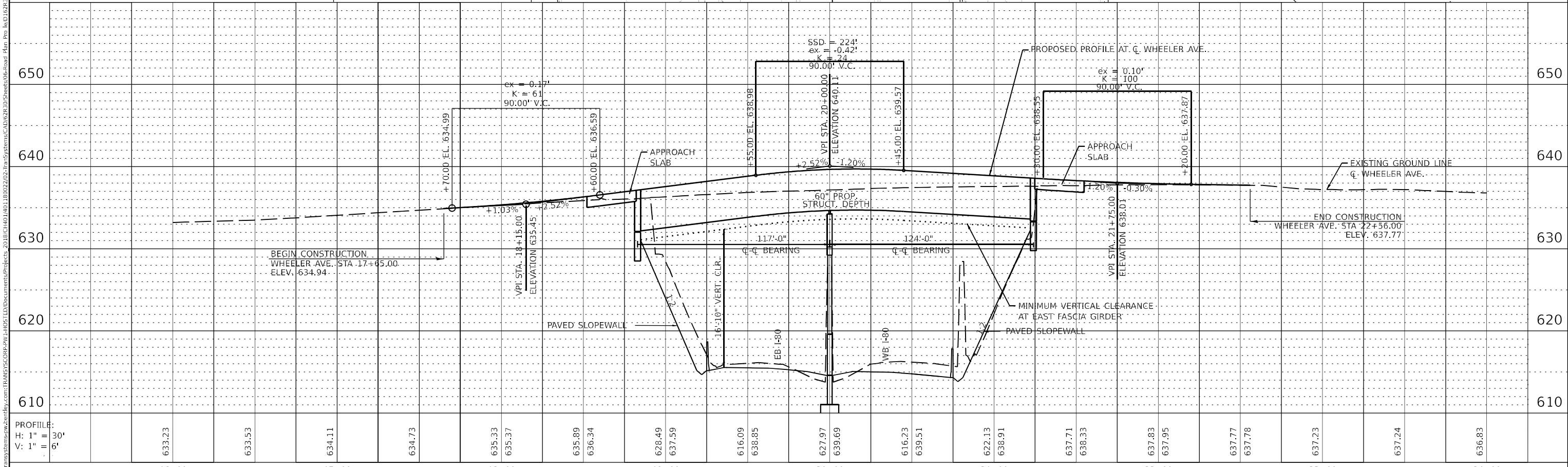
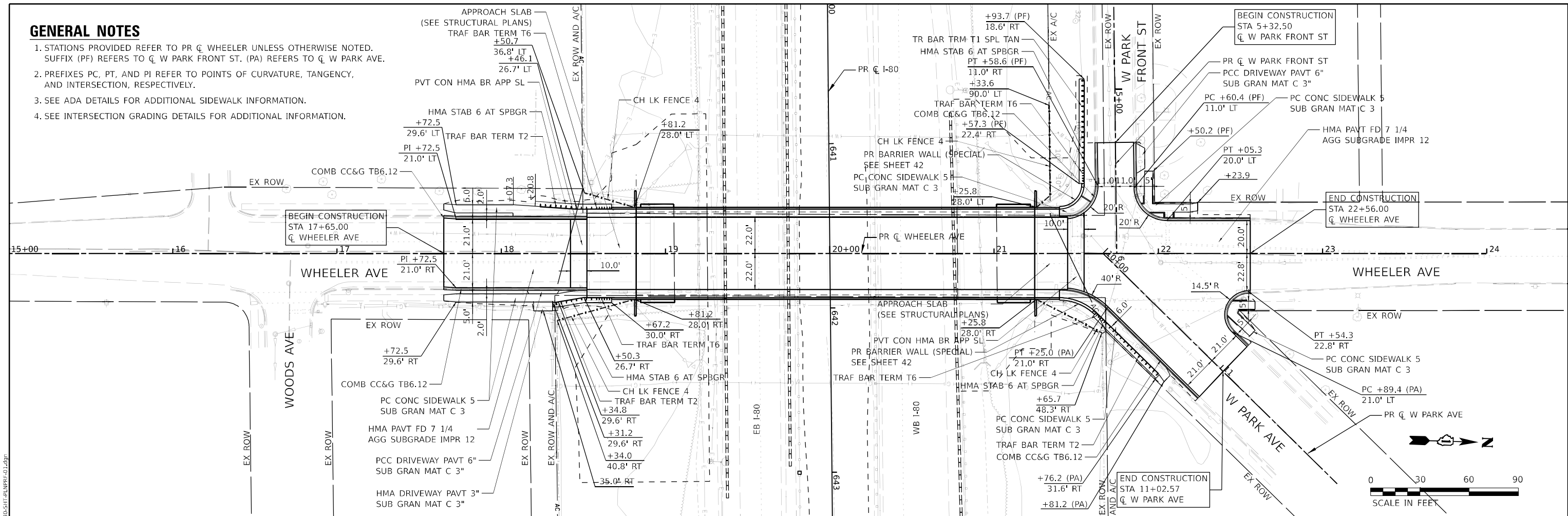

633.23	633.53	634.11	634.73	635.33	635.37	635.89	636.34	628.49	637.59	616.09	638.85	627.97	639.69	616.23	639.51	622.13	638.91	637.71	638.33	637.83	637.95	637.77	637.78	637.23	637.24	636.83
16+00	17+00	18+00	19+00	20+00	21+00	22+00	23+00	24+00																		



USER NAME = mostafan	DESIGNED - NWM	REVISED -
	DRAWN - KWM	REVISED -
PLOT SCALE = 60,000' / in.	CHECKED - SPF	REVISED -
PLOT DATE = 8/11/2022	DATE = 8/12/2022	REVISED -

**STATE OF ILLINOIS  
 DEPARTMENT OF TRANSPORTATION**

**WHEELER AVENUE OVER F.A.I. ROUTE 80  
 PLAN & PROFILE**

F.A.U. RTE.	SECTION	COUNTY	TOTAL SHEETS	SHEET NO.
340	FAI 80 21 STRUCTURE 9	WILL	130	24
CONTRACT NO. 62R30				

SCALE: 1"=30' SHEET 1 OF 2 SHEETS STA. 15+00 TO STA. 24+00

ILLINOIS FED. AID PROJECT



**NOTES**

- 1. SEE SHEET 22 FOR REMOVAL INFORMATION ALONG WHEELER AVE.
- 2. ALL STATIONING REFERS TO PR  $\bar{C}$  I-80 UNLESS OTHERWISE NOTED.
- 3. SEE MAINTENANCE OF TRAFFIC PLANS FOR TEMPORARY PAVEMENT LOCATIONS.

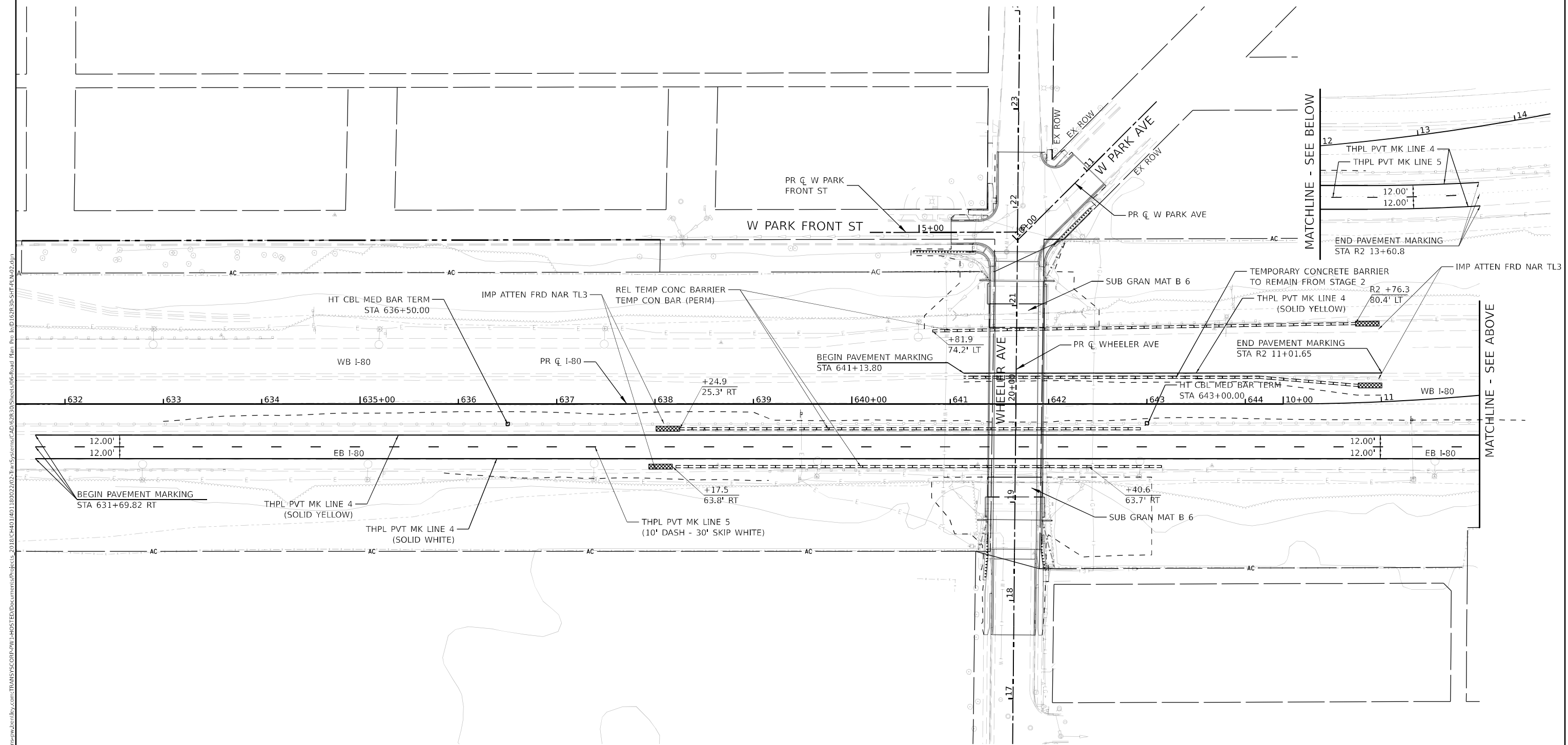

MODEL: Default  
 FILE: \\mfe-c:\public\mfe\systems\transys\scorp-pw\11\2022\0227\Transys\mfe\CD\CD\Sheet06-Road-Plan-Prd-162R30-SHT-PLAN02.dwg  
 2018/04/10 10:02:02 Transys\mfe\CD\CD\Sheet06-Road-Plan-Prd-162R30-SHT-PLAN02.dwg



USER NAME = mostafan	DESIGNED - NWM	REVISED -
PLOT SCALE = 100,000' / in.	DRAWN - KWM	REVISED -
PLOT DATE = 8/11/2022	CHECKED - SPF	REVISED -
	DATE - 8/12/2022	REVISED -

**STATE OF ILLINOIS**  
**DEPARTMENT OF TRANSPORTATION**

**WHEELER AVENUE OVER F.A.I. ROUTE 80**  
**ROADWAY AND PAVEMENT MARKING PLAN - I-80**

SCALE: 1"=50'      SHEET 2 OF 2 SHEETS      STA. 631+50      TO STA. 12+90

F.A.U. RTE.	SECTION	COUNTY	TOTAL SHEETS	SHEET NO.
340	FAI 80 21 STRUCTURE 9	WILL	130	25
CONTRACT NO. 62R30			ILLINOIS FED. AID PROJECT	



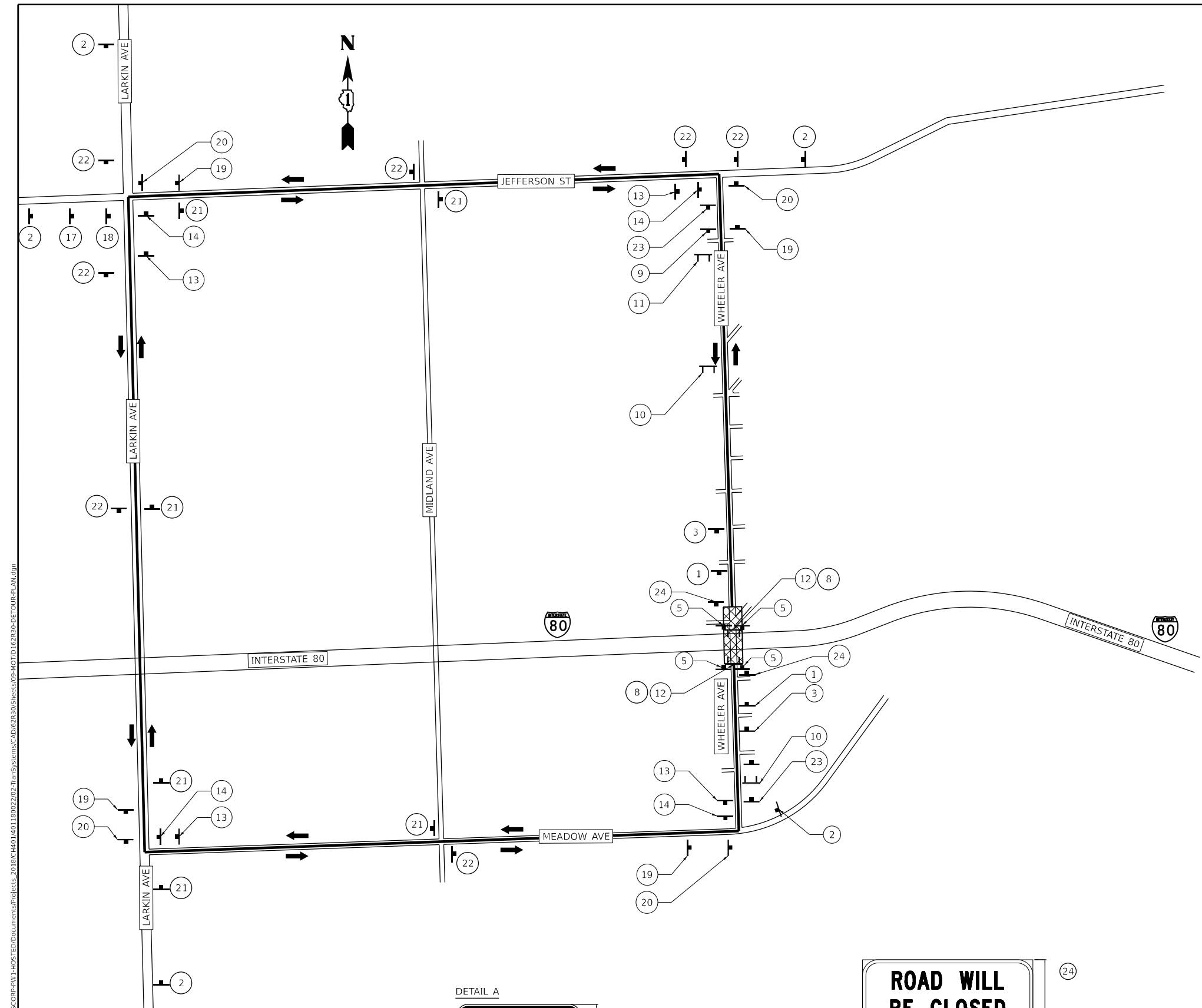

**LEGEND**

- SIGN POST
- TYPE III BARRICADE W/ TYPE A FLASHERS
- TRAFFIC FLOW
- CONSTRUCTION ZONE
- DETOUR ROUTE



1. VARIABLE 6" BLACK LETTERS ON ORANGE REFLECTIVE BACKGROUND



24

1. USE BLACK LETTERING ON ORANGE REFLECTORIZED BACKGROUND.
2. THE CONTRACTOR SHALL PLACE SIGN TWO WEEKS PRIOR TO THE ROAD CLOSURE.
3. SEE SPECIAL PROVISION FOR "TEMPORARY INFORMATION SIGNING" FOR ADDITIONAL INFORMATION.

**NOTES**

1. ALL DETOUR SIGNS SHALL BE REMOVED ONCE CONSTRUCTION IS COMPLETE AND WHEELER AVENUE IS REOPENED TO TRAFFIC.
2. ALL SIGNAGE SHALL BE IN ACCORDANCE WITH THE LATEST ILLINOIS STANDARD SPECIFICATIONS FOR ROAD AND BRIDGE CONSTRUCTION, "THE QUALITY STANDARD FOR WORK ZONE TRAFFIC CONTROL DEVICES". THE DETAILS OF THESE PLANS, THE "2009 MANUAL OF UNIFORM TRAFFIC CONTROL DEVICES", THE SPECIAL PROVISIONS FOR "TRAFFIC CONTROL AND PROTECTION, (SPECIAL)", HIGHWAY STANDARD 701901, AND THE DISTRICT DETAIL TC-21.
3. IF DEEMED NECESSARY BY THE ENGINEER, A PRE-CONSTRUCTION MEETING WITH THE CONTRACTOR SHALL BE HELD AT LEAST TWO WEEKS PRIOR TO THE DAY THE DETOUR IS TO BE IN EFFECT. THE ROAD SHALL NOT BE CLOSED UNTIL ALL DETOUR SIGNAGE IS IN PLACE.
4. ALL SIGNS SHOWN SHALL BE FURNISHED, ERECTED, AND MAINTAINED BY THE CONTRACTOR, AND SHALL BE POST-MOUNTED IN THE GROUND PER ARTICLE 701.14 OF THE STANDARD SPECIFICATIONS AND STANDARD 701901.
5. APPROPRIATE IDOT TRAFFIC CONTROL STANDARDS SHALL BE USED TO INSTALL AND REMOVE TRAFFIC CONTROL AND PROTECTION DEVICES
6. TWO PCMS ALONG WHEELER AVENUE (ONE NORTH AND ONE SOUTH OF I-80) HAVE BEEN INCLUDED IN THE CONTRACT. COORDINATE WITH THE CITY OF JOLIET TO DETERMINE LOCATION.
7. W PARK AVE AND W PARK FRONT ST SHALL REMAIN OPEN TO TRAFFIC AT ALL TIMES.
8. ACCESS TO DRIVEWAYS SHALL BE MAINTAINED AT ALL TIMES.

**SCHEDULE OF DETOUR SIGNS**

1.  ROAD CLOSED 500 FT W20-3-4848	2.  DETOUR AHEAD W20-2a-4848	3.  ROAD CLOSED AHEAD W20-3-4848	4. NOT USED
5.  SIDEWALK CLOSED R11-101-2418	6.  DETOUR M4-10R-4818	7.  DETOUR M4-10L-4818	8.  BRIDGE OUT R11-2-4830
9.  BRIDGE OUT 0.7 MILES AHEAD LOCAL TRAFFIC ONLY R11-3b-6030	10.  BRIDGE OUT 1/2 MILE AHEAD LOCAL TRAFFIC ONLY R11-3b-6030	11.  ROAD CLOSED TO THRU TRAFFIC R11-4-6030	12.  ROAD CLOSED R11-2-4130
13.  NORTH WHEELER AVE SEE DETAIL A M4-9R-3024	14.  NORTH WHEELER AVE SEE DETAIL A M4-9R-3024	15.  NORTH WHEELER AVE SEE DETAIL A M4-9L-3024	
16.  SOUTH WHEELER AVE SEE DETAIL A M4-9L-3024	17.  SOUTH WHEELER AVE SEE DETAIL A M4-9R-3024	18.  SOUTH WHEELER AVE SEE DETAIL A M4-9R-3024	
19.  SOUTH WHEELER AVE SEE DETAIL A M4-9L-3024	20.  SOUTH WHEELER AVE SEE DETAIL A M4-9L-3024	21.  NORTH WHEELER AVE SEE DETAIL A M4-9S-3024	
22.  SOUTH WHEELER AVE SEE DETAIL A M4-9S-3024	23.  END DETOUR M4-8a-2418		



USER NAME = mostafan	DESIGNED - NWM	REVISED -
PLOT SCALE = 1000,000' / in.	DRAWN - KWM	REVISED -
PLOT DATE = 8/10/2022	CHECKED - SPF	REVISED -
	DATE - 8/12/2022	REVISED -

STATE OF ILLINOIS  
DEPARTMENT OF TRANSPORTATION





WHEELER AVENUE OVER F.A.I. ROUTE 80  
WHEELER AVE BRIDGE DETOUR ROUTE

F.A.U. RTE.	SECTION	COUNTY	TOTAL SHEETS	SHEET NO.
340	FAI 80 21 STRUCTURE 9	WILL	130	27
CONTRACT NO. 62R30				
		ILLINOIS	FED. AID PROJECT	

SCALE: N.T.S. SHEET 2 OF 2 SHEETS STA. TO STA.

MODEL: Default  
 FILE: WHEELER\_AVE\_TRANSPORTATION\_PROJECTS\_201808140110002702-TrafficSystem/CADD/201808140110002702-TRAFFIC/DETOUR\_ROUTE.dgn  
 PROJECT: TRANSPORTATION\_PROJECTS\_201808140110002702-TrafficSystem/CADD/201808140110002702-TRAFFIC/DETOUR\_ROUTE.dgn  
 USER: mostafan

**LEGEND**

-  AVAILABLE WORK ZONE
-  TEMPORARY PAVEMENT (PREVIOUSLY COMPLETED)
-  DIRECTION OF TRAFFIC FLOW
-  TEMPORARY CONCRETE BARRIER
-  TYPE II BARRICADES OR DRUMS

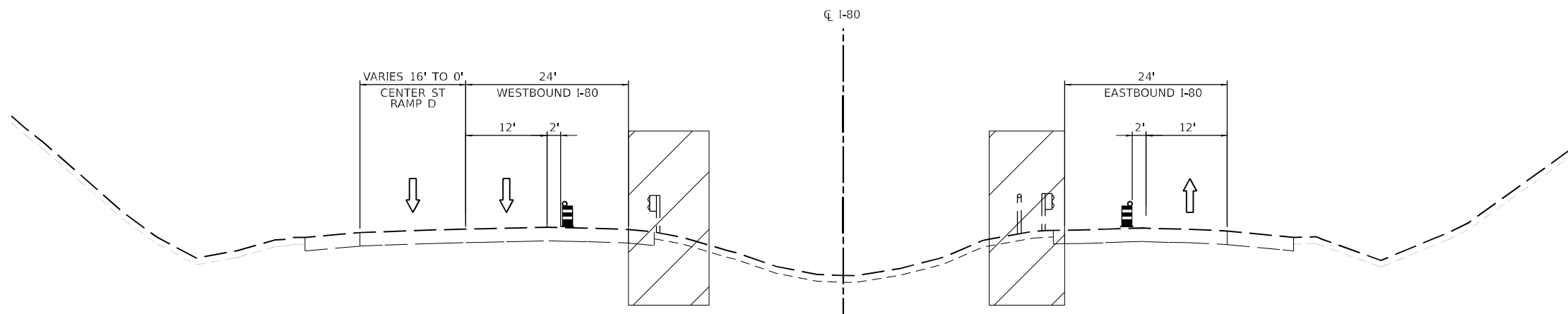

**PRESTAGE – CONFIGURATION A**

WORK DURING NIGHTLY ALLOWABLE LANE CLOSURES ONLY  
 I-80  
 LOOKING EAST  
 STA 633+00 TO R2 12+45

- ① TEMPORARY PAVEMENT MARKING - LINE 4" - EPOXY (SOLID YELLOW)
- ② TEMPORARY PAVEMENT MARKING - LINE 4" - EPOXY (SOLID WHITE)
- ③ TEMPORARY PAVEMENT MARKING - LINE 5" - EPOXY (10' DASH, 30' SKIP, WHITE)

NOTES:

TYPE C BARRIER WALL REFLECTORS SHALL BE PLACED EVERY 25' ALONG TEMPORARY CONCRETE BARRIER.

REFLECTORS SHALL BE MOUNTED ON TOP OF BARRIER AND THE FACE ADJACENT TO TRAFFIC, ACCORDING TO STANDARD 704001-08. WHERE TEMPORARY CONCRETE BARRIER IS SEPARATING OPPOSING TRAFFIC, REFLECTORS SHALL BE USED ON BOTH SIDES.

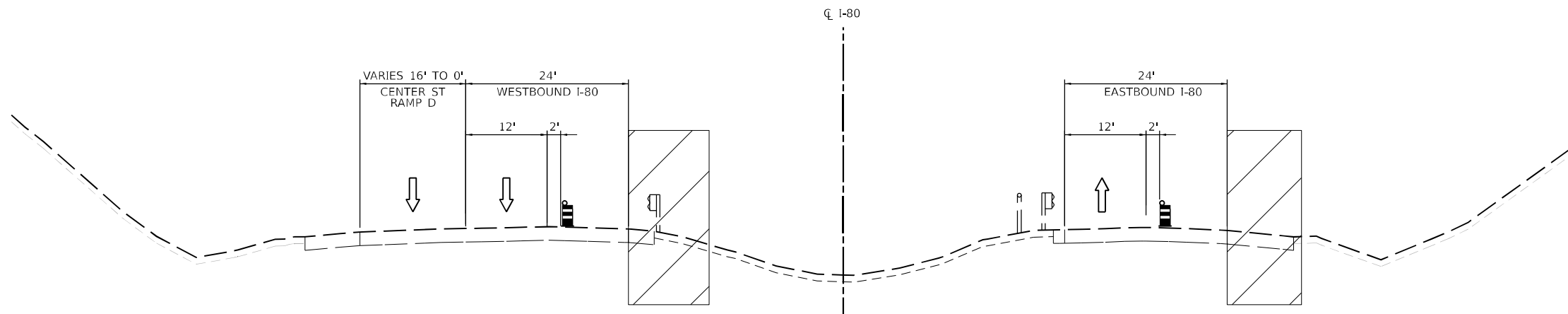

**PRESTAGE – CONFIGURATION B**

WORK DURING NIGHTLY ALLOWABLE LANE CLOSURES ONLY  
 I-80  
 LOOKING EAST  
 STA 633+00 TO R2 12+45

MODEL: Default  
 FILE: \\miller\p\proj\trans\scorp\p\11\hst\ed\documents\proj\clus\_2018\CH401\401\_100027\02-TransSystems\CAD\02R30\Sheet\09A-MOT\102R30-5-5-14-MOTTYR-01.dwg



USER NAME = mostafan	DESIGNED - NWM	REVISED -
	DRAWN - KWM	REVISED -
PLOT SCALE = 20,000' / in.	CHECKED - SPF	REVISED -
PLOT DATE = 8/10/2022	DATE - 8/12/2022	REVISED -





**STATE OF ILLINOIS  
 DEPARTMENT OF TRANSPORTATION**

**WHEELER AVENUE OVER F.A.I. ROUTE 80  
 I-80 MAINTENANCE OF TRAFFIC TYPICAL SECTIONS**

SCALE: N.T.S. SHEET 1 OF 2 SHEETS STA. TO STA.

F.A.U. RTE.	SECTION	COUNTY	TOTAL SHEETS	SHEET NO.
340	FAI 80 21 STRUCTURE 9	WILL	130	28
				CONTRACT NO. 62R30
		ILLINOIS	FED. AID PROJECT	

**LEGEND**

-  AVAILABLE WORK ZONE
-  TEMPORARY PAVEMENT (PREVIOUSLY COMPLETED)
-  DIRECTION OF TRAFFIC FLOW
-  TEMPORARY CONCRETE BARRIER
-  TYPE II BARRICADES OR DRUMS

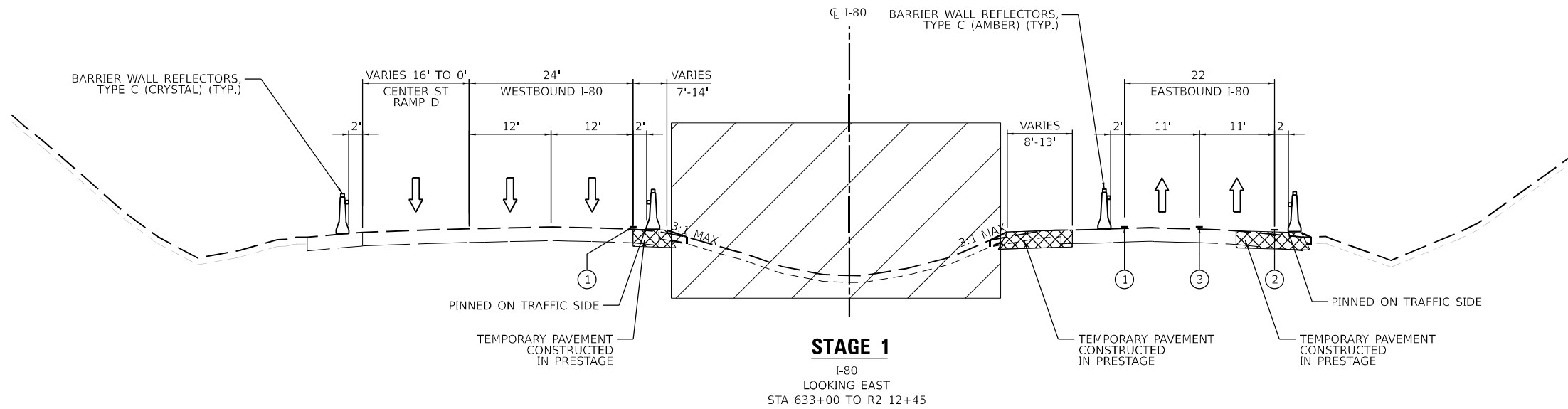

**STAGE 1**  
I-80  
LOOKING EAST  
STA 633+00 TO R2 12+45

- ① TEMPORARY PAVEMENT MARKING - LINE 4" - EPOXY (SOLID YELLOW)
- ② TEMPORARY PAVEMENT MARKING - LINE 4" - EPOXY (SOLID WHITE)
- ③ TEMPORARY PAVEMENT MARKING - LINE 5" - EPOXY (10' DASH, 30' SKIP, WHITE)

NOTES:

TYPE C BARRIER WALL REFLECTORS SHALL BE PLACED EVERY 25' ALONG TEMPORARY CONCRETE BARRIER.

REFLECTORS SHALL BE MOUNTED ON TOP OF BARRIER AND THE FACE ADJACENT TO TRAFFIC, ACCORDING TO STANDARD 704001-08. WHERE TEMPORARY CONCRETE BARRIER IS SEPARATING OPPOSING TRAFFIC, REFLECTORS SHALL BE USED ON BOTH SIDES.

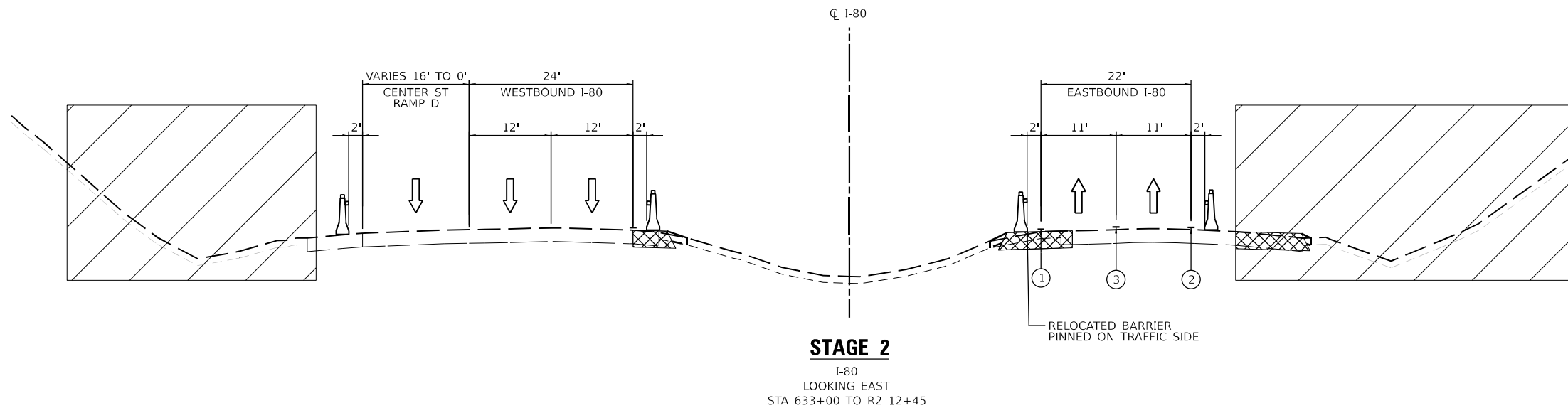

**STAGE 2**  
I-80  
LOOKING EAST  
STA 633+00 TO R2 12+45

MODEL - Default  
 FILE - Model - I-80 Maintenance of Traffic Typical Sections - 20180710-110022-02-Traffic Systems/CD/1023039-09-MOTI-02.dwg  
 PROJECT - I-80 MAINTENANCE OF TRAFFIC TYPICAL SECTIONS  
 USER - mostafan  
 DESIGNED - NWM  
 DRAWN - KWM  
 CHECKED - SPF  
 DATE - 8/12/2022  
 REVISIONS -  
 REVISIONS -  
 REVISIONS -  
 REVISIONS -  
 STATE OF ILLINOIS  
 DEPARTMENT OF TRANSPORTATION  
 WHEELER AVENUE OVER F.A.I. ROUTE 80  
 I-80 MAINTENANCE OF TRAFFIC TYPICAL SECTIONS  
 SCALE: N.T.S.  
 SHEET 2 OF 2 SHEETS  
 STA. TO STA.  
 F.A.U. RTE. SECTION COUNTY TOTAL SHEETS SHEET NO.  
 340 FAI 80 21 STRUCTURE 9 WILL 130 29  
 CONTRACT NO. 62R30  
 ILLINOIS FED. AID PROJECT



USER NAME = mostafan	DESIGNED - NWM	REVISED -
	DRAWN - KWM	REVISED -
PLOT SCALE = 20,000' / in.	CHECKED - SPF	REVISED -
PLOT DATE = 8/10/2022	DATE - 8/12/2022	REVISED -

**STATE OF ILLINOIS  
DEPARTMENT OF TRANSPORTATION**

**WHEELER AVENUE OVER F.A.I. ROUTE 80  
I-80 MAINTENANCE OF TRAFFIC TYPICAL SECTIONS**

F.A.U. RTE.	SECTION	COUNTY	TOTAL SHEETS	SHEET NO.
340	FAI 80 21 STRUCTURE 9	WILL	130	29
CONTRACT NO. 62R30				

**LEGEND**

WORK AREA

TEMPORARY PAVEMENT (PLACED IN PRE-STAGE)

TEMPORARY PAVEMENT

IMPACT ATTENUATORS, TEMPORARY

TEMPORARY CONCRETE BARRIER

DIRECTION OF TRAFFIC

TRAFFIC CONTROL DRUMS

SIGN

TYPE III BARRICADE

① TEMPORARY PAVEMENT MARKING - LINE 4" - EPOXY (SOLID YELLOW)

② TEMPORARY PAVEMENT MARKING - LINE 4" - EPOXY (SOLID WHITE)

③ TEMPORARY PAVEMENT MARKING - LINE 5" - EPOXY (10' DASH, 30' SKIP, WHITE)

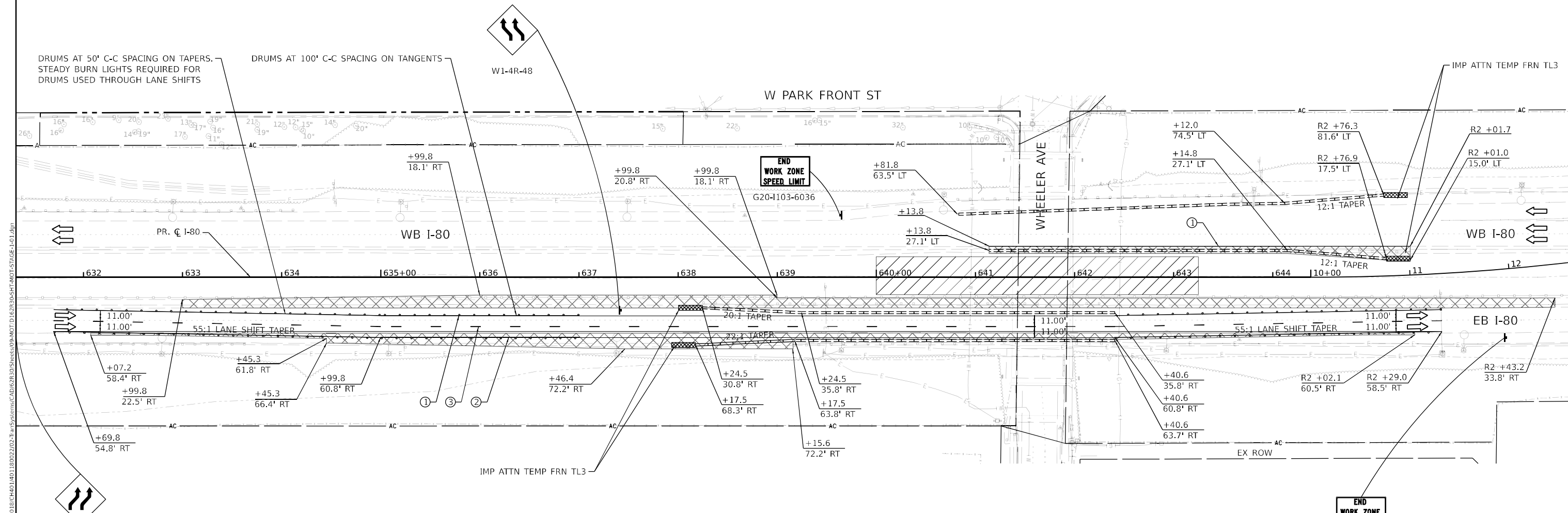

DRUMS AT 50' C-C SPACING ON TAPERS. STEADY BURN LIGHTS REQUIRED FOR DRUMS USED THROUGH LANE SHIFTS

DRUMS AT 100' C-C SPACING ON TANGENTS

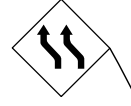

W1-4R-48

W PARK FRONT ST

WHEELER AVE

IMP ATTN TEMP FRN TL3

END WORK ZONE SPEED LIMIT  
G20-1103-6036

END WORK ZONE SPEED LIMIT  
G20-1103-6036



W1-4R-48

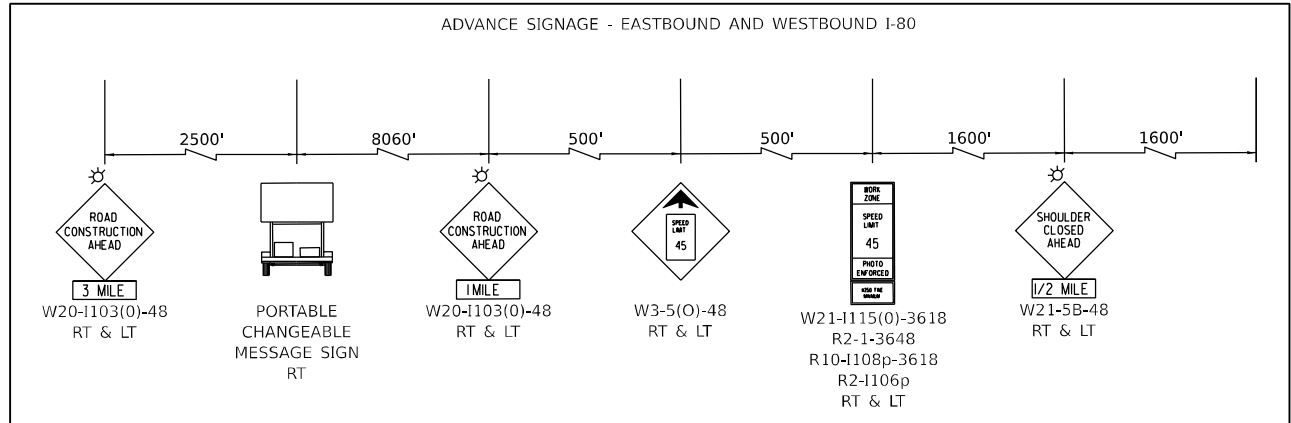
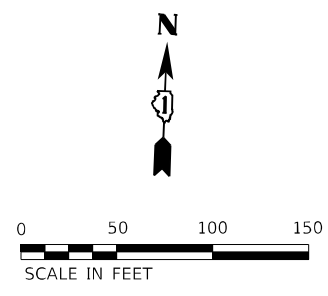

USER NAME = mostafan	DESIGNED - NWM	REVISED -
PLOT SCALE = 100,000' / in.	DRAWN - KWM	REVISED -
PLOT DATE = 8/11/2022	CHECKED - SPF	REVISED -
	DATE - 8/12/2022	REVISED -

STATE OF ILLINOIS  
DEPARTMENT OF TRANSPORTATION

WHEELER AVENUE OVER F.A.I. ROUTE 80  
MAINTENANCE OF TRAFFIC PLAN - STAGE 1

SCALE: 1"=50' SHEET 1 OF 2 SHEETS STA. 631+32 TO STA. 14+00

F.A.U. RTE.	SECTION	COUNTY	TOTAL SHEETS	SHEET NO.
340	FAI 80 21 STRUCTURE 9	WILL	130	30
CONTRACT NO. 62R30				
ILLINOIS		FED. AID PROJECT		

MODEL: Default FILE: WHEELER\_PlanViewTrafficMaintenanceStage1.dwg

**LEGEND**

- WORK AREA
- TEMPORARY PAVEMENT (PLACED IN PRE-STAGE)
- TEMPORARY PAVEMENT

- IMPACT ATTENUATORS, TEMPORARY
- TEMPORARY CONCRETE BARRIER
- DIRECTION OF TRAFFIC
- TRAFFIC CONTROL DRUMS
- SIGN
- TYPE III BARRICADE

- ① TEMPORARY PAVEMENT MARKING - LINE 4" - EPOXY (SOLID YELLOW)
- ② TEMPORARY PAVEMENT MARKING - LINE 4" - EPOXY (SOLID WHITE)
- ③ TEMPORARY PAVEMENT MARKING - LINE 5" - EPOXY (10' DASH, 30' SKIP, WHITE)

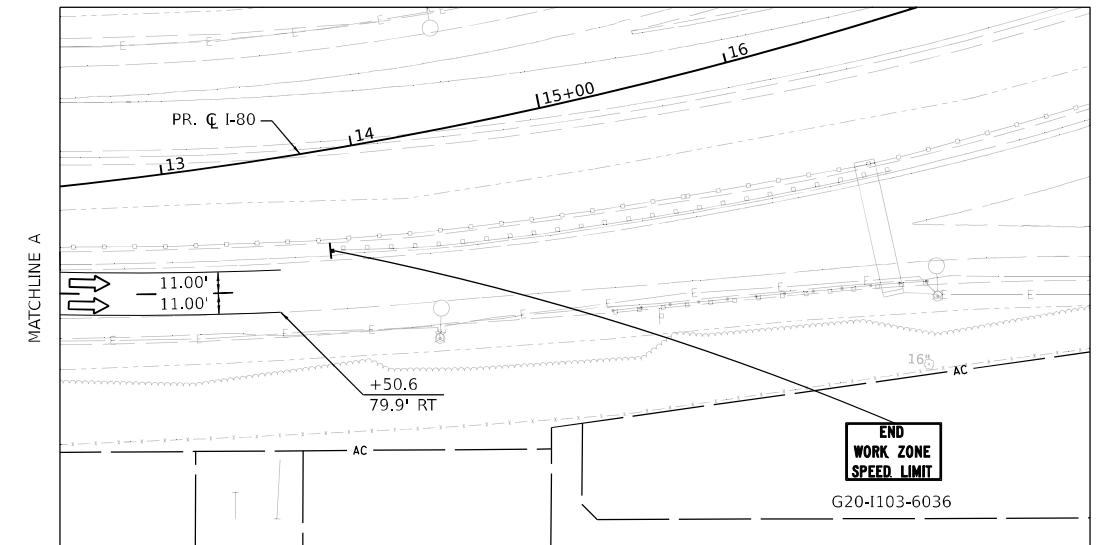

DRUMS AT 50' C-C SPACING ON TAPERS.  
STEADY BURN LIGHTS REQUIRED FOR  
DRUMS USED THROUGH LANE SHIFTS

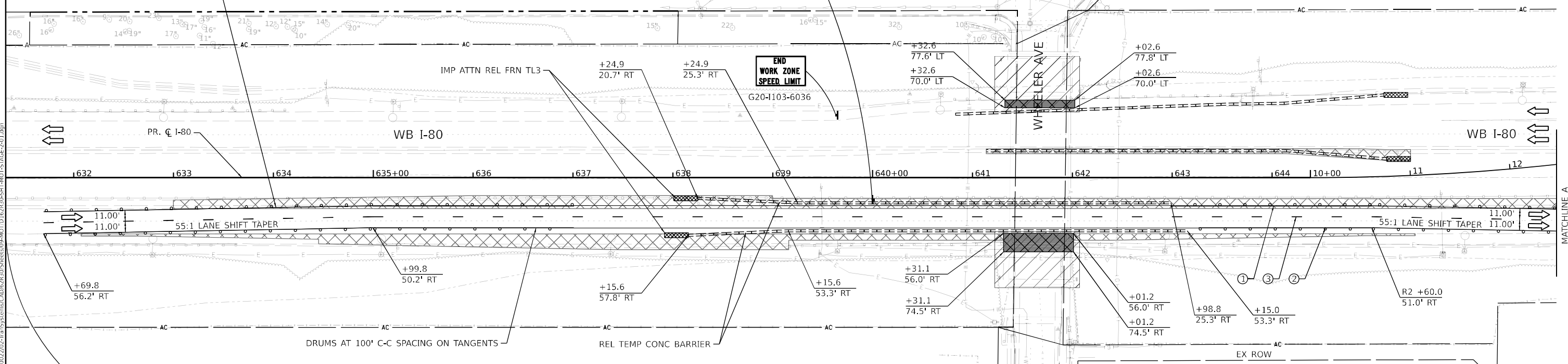

W1-4R-48

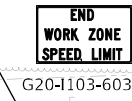

G20-1103-6036



W1-4R-48

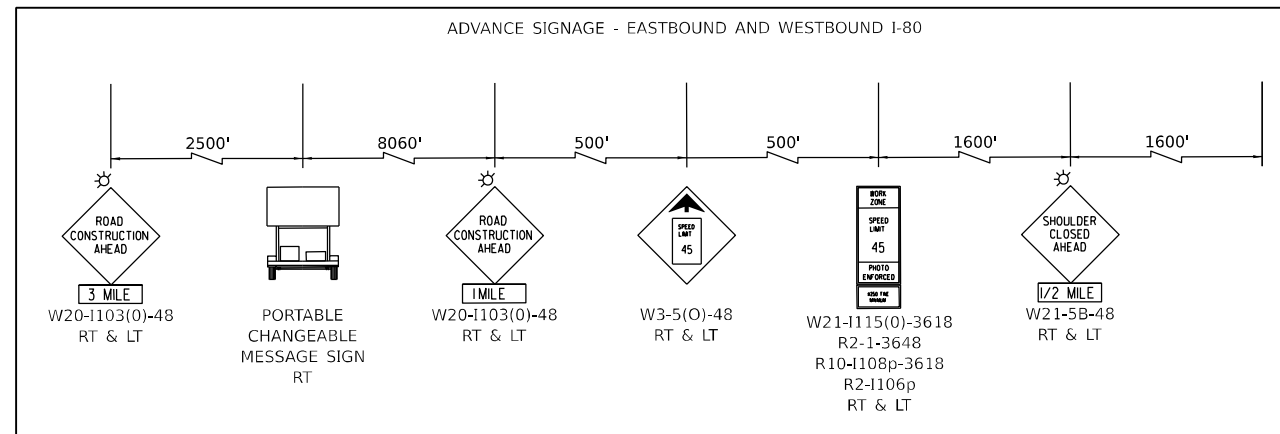
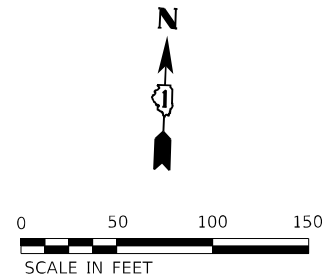

USER NAME = mostafan	DESIGNED - NWM	REVISED -
PLOT SCALE = 100,000' / in.	DRAWN - KWM	REVISED -
PLOT DATE = 8/11/2022	CHECKED - SPF	REVISED -
	DATE - 8/12/2022	REVISED -

**STATE OF ILLINOIS  
DEPARTMENT OF TRANSPORTATION**

**WHEELER AVENUE OVER F.A.I. ROUTE 80  
MAINTENANCE OF TRAFFIC PLAN - STAGE 2**

SCALE: 1"=50' SHEET 2 OF 2 SHEETS STA. 631+32 TO STA. 14+00

F.A.U. RTE.	SECTION	COUNTY	TOTAL SHEETS	SHEET NO.
340	FBI 80 21 STRUCTURE 9	WILL	130	31
CONTRACT NO. 62R30				
ILLINOIS FED. AID PROJECT				

MODEL: Default FILE: WHEELER\_PlanTrafficStage2.dwg DATE: 8/11/2022 10:00:00 AM USER: mostafan

**EROSION CONTROL GENERAL NOTES:**

1. ALL ESC MEASURES WILL BE MAINTAINED IN ACCORDANCE WITH THE IDOT EROSION AND SEDIMENT CONTROL FIELD GUIDE FOR CONSTRUCTION INSPECTION FOUND ON THE CONSTRUCTION TAB AT: [HTTP://WWW.IDOT.ILLINOIS.GOV/TRANSPORTATION-SYSTEM/ENVIRONMENT/EROSION-AND-SEDIMENT-CONTROL](http://www.idot.illinois.gov/transportation-system/environment/erosion-and-sediment-control)
2. THE CONTRACTOR WILL ASSUME RESPONSIBILITY FOR MAINTENANCE OF ALL SOIL EROSION CONTROL DURING CONSTRUCTION.
3. THE CONTRACTOR SHALL CHECK ALL ESC MEASURES WEEKLY AND AFTER EACH RAINFALL, 0.5 INCHES OR GREATER IN A 24-HOUR PERIOD, OR EQUIVALENT SNOWFALL. ADDITIONALLY, DURING WINTER MONTHS, ALL MEASURES SHOULD BE CHECKED BY THE CONTRACTOR AFTER EACH SIGNIFICANT SNOWMELT.
4. ANY LOOSE MATERIAL DEPOSITED IN THE FLOW LINE OF DRAINAGE STRUCTURES, WHICH OBSTRUCTS THE NATURAL FLOW OF WATER, SHALL BE REMOVED AT THE CLOSE OF EACH WORKING DAY. PRIOR TO ACCEPTANCE OF THE IMPROVEMENT, ALL DRAINAGE STRUCTURES SHALL BE FREE OF DIRT AND DEBRIS. THIS WORK WILL NOT BE PAID FOR SEPARATELY BUT SHALL BE CONSIDERED INCIDENTAL.
5. TEMPORARY OR PERMANENT STABILIZATION SHALL BE INITIATED IMMEDIATELY UPON COMPLETION OF DISTURBANCE OR IF THE WORK AREA IS TO BE LEFT UNDISTURBED FOR 14 DAYS OR MORE.
6. UNDER NO CIRCUMSTANCES SHALL THE CONTRACTOR PROLONG FINAL GRADING AND SHAPING SO THAT THE ENTIRE PROJECT CAN BE PERMANENTLY SEEDING AT ONE TIME.
7. THE CONTRACTOR IS RESPONSIBLE FOR INSTALLATION OF ANY ADDITIONAL EROSION CONTROL MEASURES NECESSARY TO PREVENT EROSION AND SEDIMENTATION AS DETERMINED BY THE RESIDENT ENGINEER.
8. THE CONTRACTOR SHALL PROVIDE THE RE A PLAN TO ENSURE THAT A STABILIZED FLOW LINE WILL BE PROVIDED DURING STORM SEWER CONSTRUCTION. THE USE OF A STABILIZED FLOW LINE BETWEEN INSTALLED STORM SEWER AND OPEN DISTURBANCE WILL REDUCE THE POTENTIAL FOR THE OFFSITE DISCHARGE OF SEDIMENT-BEARING WATERS, ESPECIALLY WHEN RAIN IS FORECASTED, SO THAT FLOW WILL NOT ERODE. LACK OF APPROVED PLAN OR FAILURE TO COMPLY WILL RESULT IN AN ESC DEFICIENCY DEDUCTION.

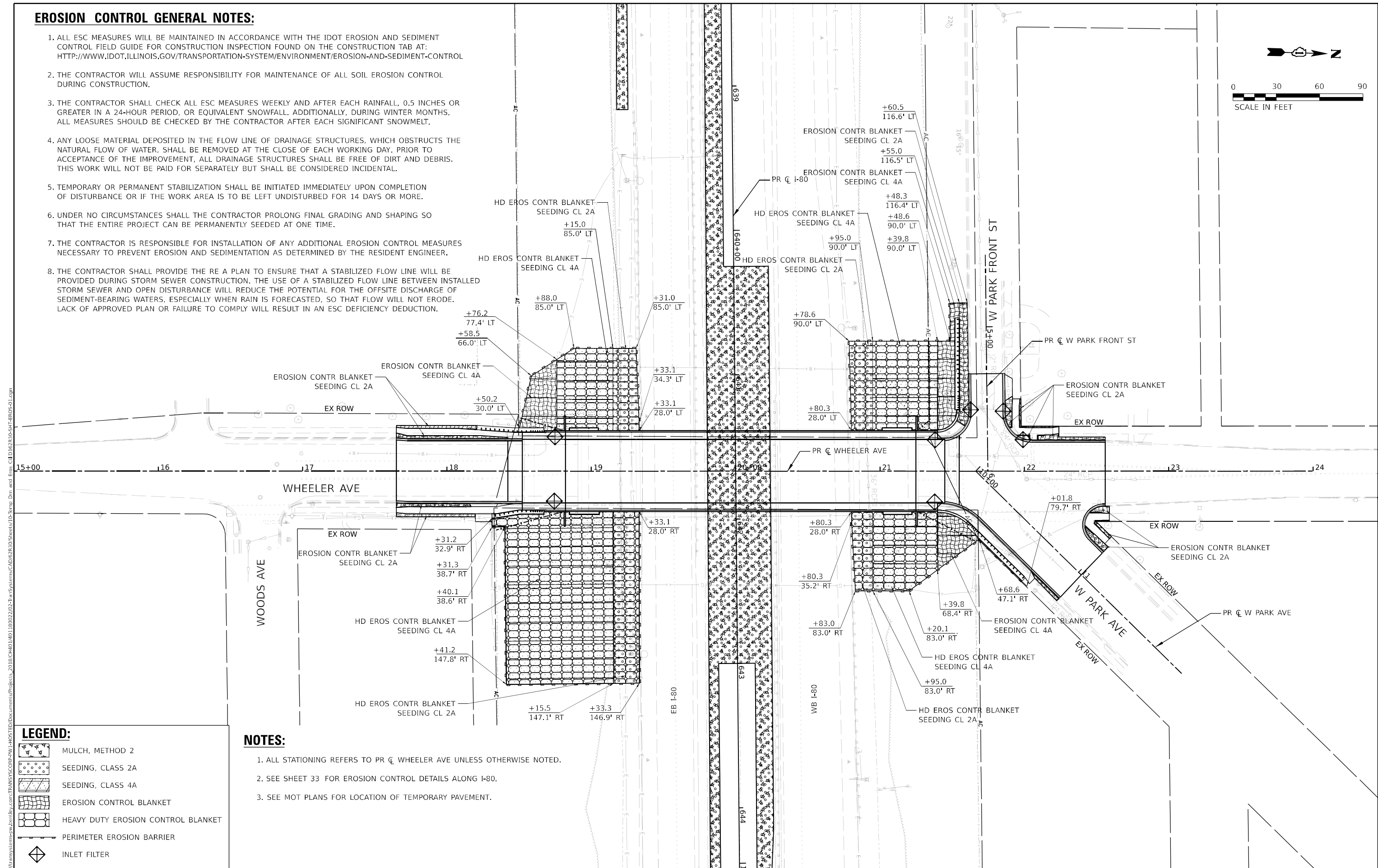
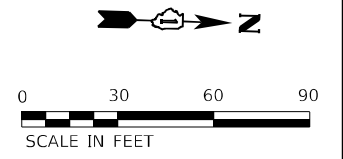

**LEGEND:**

- MULCH, METHOD 2
- SEEDING, CLASS 2A
- SEEDING, CLASS 4A
- EROSION CONTROL BLANKET
- HEAVY DUTY EROSION CONTROL BLANKET
- PERIMETER EROSION BARRIER
- INLET FILTER

- NOTES:**
1. ALL STATIONING REFERS TO PR C WHEELER AVE UNLESS OTHERWISE NOTED.
  2. SEE SHEET 33 FOR EROSION CONTROL DETAILS ALONG I-80.
  3. SEE MOT PLANS FOR LOCATION OF TEMPORARY PAVEMENT.



USER NAME = mostafan	DESIGNED - NWM	REVISED -
PLOT SCALE = 60,000' / in.	DRAWN - KWM	REVISED -
PLOT DATE = 8/11/2022	CHECKED - SPF	REVISED -
	DATE - 8/12/2022	REVISED -

**STATE OF ILLINOIS  
DEPARTMENT OF TRANSPORTATION**

**WHEELER AVENUE OVER F.A.I. ROUTE 80  
EROSION AND SEDIMENT CONTROL PLAN - WHEELER AVE**

SCALE: 1"=30'    SHEET 1 OF 2 SHEETS    STA. 15+00    TO STA. 24+00

F.A.U. RTE.	SECTION	COUNTY	TOTAL SHEETS	SHEET NO.
340	FBI 80 21 STRUCTURE 9	WILL	130	32
CONTRACT NO. 62R30				
ILLINOIS FED. AID PROJECT				

MODEL: Defaul  
 FILE: \\msys\comps\p\h\ba\l\c\m\TRANSPORTATION\Documents\Projects\2018\CH401\40110022\02-TrafficSystem\CD\62R30\Sheet10.dwg and Ex: CLID:62R30\54T-EROS-01.dgn



**LEGEND:**

	MULCH, METHOD 2
	SEEDING, CLASS 2A
	SEEDING, CLASS 4A
	EROSION CONTROL BLANKET
	HEAVY DUTY EROSION CONTROL BLANKET
	PERIMETER EROSION BARRIER
	INLET FILTER

**NOTES:**

- SEE SHEET 32 FOR EROSION CONTROL GENERAL NOTES AND EROSION CONTROL DETAILS ALONG EMBANKMENT AND ALONG WHEELER AVENUE.
- ALL STATIONING REFERS TO PR CL I-80 UNLESS OTHERWISE NOTED.
- SEE MOT PLANS FOR LOCATION OF TEMPORARY PAVEMENT.

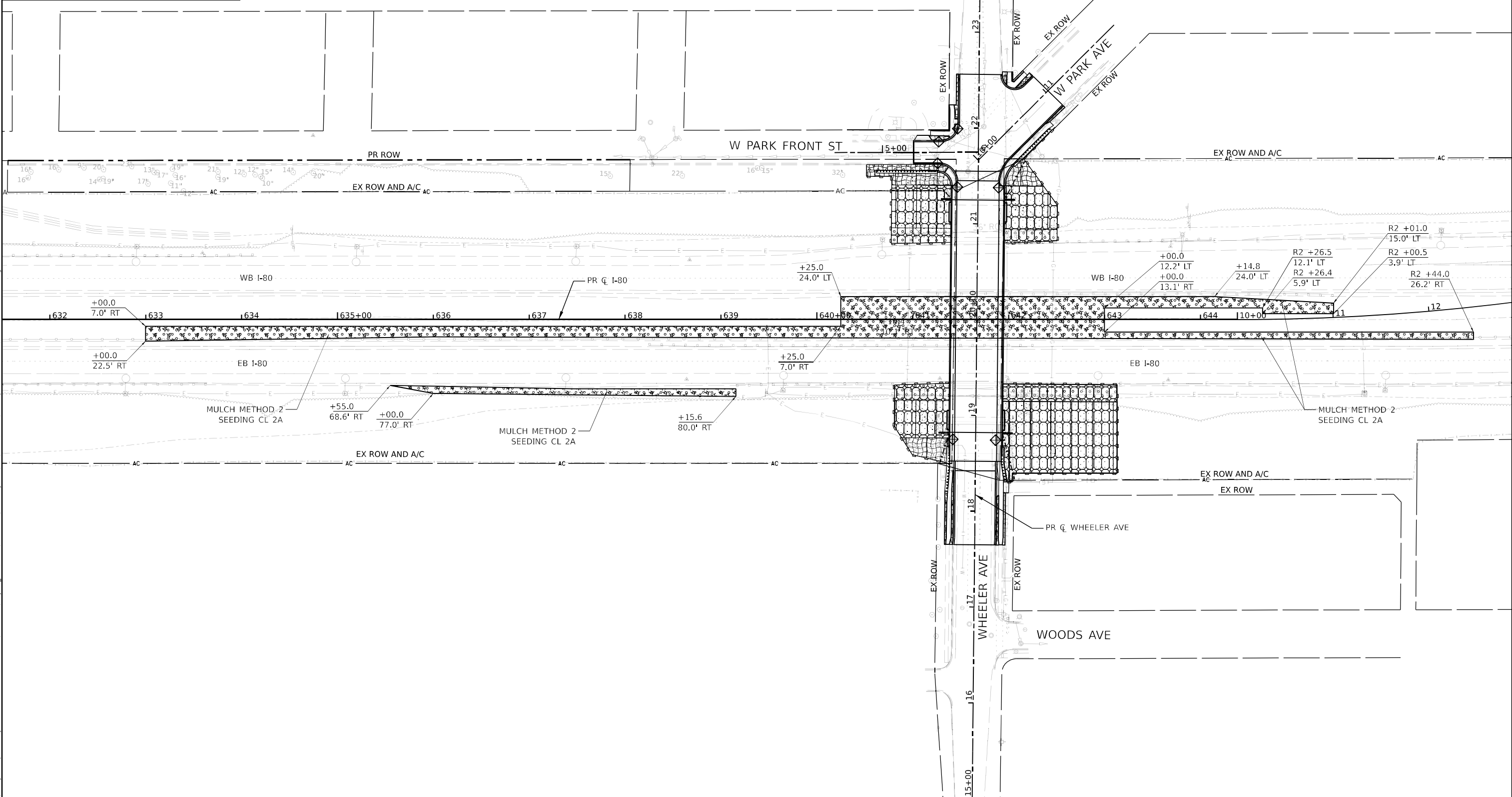
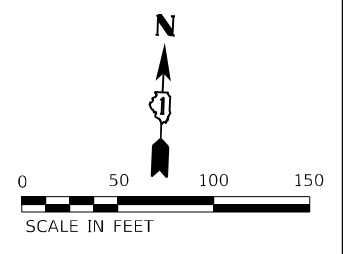

MODEL: Default  
 FILE: \\miller-planning-systems.com\projects\2018\CH401\401\10002702-TrafficSystems\CD\62R30-Sheet12-Dwg.dwg and Eas: CLD:62R30-SHT-EROS-02.dwg  
 PROJECT: TRANSPORTATION PROJECTS  
 DATE: 8/11/2022



USER NAME = mostafan	DESIGNED - NWM	REVISED -
DRAWN - KWM	REVISED -	
PLOT SCALE = 100,000' / in.	CHECKED - SPF	REVISED -
PLOT DATE = 8/11/2022	DATE - 8/12/2022	REVISED -

303 EAST WACKER DRIVE, SUITE 1400 CHICAGO, IL 60601-2776 PHONE: (312) 373-7700 FAX: (312) 373-6800
--

**STATE OF ILLINOIS  
 DEPARTMENT OF TRANSPORTATION**

**WHEELER AVENUE OVER F.A.I. ROUTE 80  
 EROSION AND SEDIMENT CONTROL PLAN - I-80**

SCALE: 1"=50'    SHEET 2 OF 2 SHEETS    STA. 631+50    TO STA. 12+90

F.A.U. RTE.	SECTION	COUNTY	TOTAL SHEETS	SHEET NO.
340	FAI 80 21 STRUCTURE 9	WILL	130	33
CONTRACT NO. 62R30				
ILLINOIS FED. AID PROJECT				

**EXISTING DRAINAGE AND UTILITY STRUCTURE SCHEDULE**

STATION	OFFSET	TYPE	MANHOLES TO BE ADJUSTED	VALVE VAULTS TO BE ADJUSTED WITH NEW TYPE 1 FRAME, CLOSED LID	VALVE BOXES TO BE ADJUSTED	REMOVING MANHOLES	REMOVING INLETS	COMMENTS		
			60255500	60265900	60266600	60500040	60500060			
			EACH	EACH	EACH	EACH	EACH			
18+74.74	23.2' RT	INLET					1			
18+75.30	24.5' LT	INLET					1			
21+37.79	21.8' RT	INLET					1			
21+38.13	21.6' LT	INLET					1			
21+54.37	10.6' LT	WATER VALVE VAULT		1				EX RIM EL = 637.63	PR RIM EL = 638.12	
21+58.85	25.8' RT	MANHOLE				1				
21+62.38	42.1' LT	INLET					1			
21+70.88	43.5' LT	MANHOLE	1					EX RIM EL = 636.43	PR RIM EL = 636.99	EX INV NE = 625.98; EX INV W = 625.88; EX INV N = 633.33; EX INV S = 633.33
21+86.20	41.8' LT	INLET					1			
21+97.32	30.2' RT	WATER VALVE BOX			1			EX RIM EL = 637.65	PR RIM EL = 637.52	
21+97.97	22.0' LT	INLET					1			
22+01.53	5.54' RT	MANHOLE	1					EX RIM EL = 637.85	PR RIM EL = 637.75	
<b>TOTAL</b>			<b>2</b>	<b>1</b>	<b>1</b>	<b>1</b>	<b>7</b>			

MODEL Default  
FILE: \\miller\p\m\trans\systems\trans\proj\c\2018\F401401\100027\02-Trans\Systems\CAD\DWG\2018\Sheet\03-Structures\03-Structures.dwg



USER NAME = mostafan  
 PLOT SCALE = 2,000' / in.  
 PLOT DATE = 8/10/2022

DESIGNED - NWM  
 DRAWN - KWM  
 CHECKED - SPF  
 DATE - 8/12/2022

REVISED -  
 REVISED -  
 REVISED -  
 REVISED -

**STATE OF ILLINOIS  
 DEPARTMENT OF TRANSPORTATION**

**WHEELER AVENUE OVER F.A.I. ROUTE 80  
 DRAINAGE AND UTILITY SCHEDULES**

SCALE: N.T.S. SHEET 1 OF 2 SHEETS STA. TO STA.

F.A.U. RTE.	SECTION	COUNTY	TOTAL SHEETS	SHEET NO.
340	FAI 80 21 STRUCTURE 9	WILL	130	34
CONTRACT NO. 62R30				
ILLINOIS			FED. AID PROJECT	

**PROPOSED DRAINAGE STRUCTURE SCHEDULE**

STRUCTURE	STATION	OFFSET	STATION AND OFFSET LOCATION (FLOWLINE OR CENTER OF STRUCTURE)	RIM (ELEV)	N. INVERT (ELEV)	S. INVERT (ELEV)	E. INVERT (ELEV)	W. INVERT (ELEV)	NE. INVERT (ELEV)	NW. INVERT (ELEV)	SE. INVERT (ELEV)	SW. INVERT (ELEV)	END SECTIONS 12"	CATCH BASINS, TYPE A, 4'-DIAMETER, TYPE 11 FRAME AND GRATE	MANHOLES, TYPE A, 4'-DIAMETER, TYPE 1 FRAME, CLOSED LID	INLETS, TYPE A, TYPE 11 FRAME AND GRATE
													54213447	60201105	60218400	60236800
													EACH	EACH	EACH	EACH
S-01	18+40.00	22.00' LT	FL	635.74			633.07									1
S-02	18+40.00	22.00' RT	FL	635.74				631.87				629.74		1		
S-03	18+97.09	72.40' RT	COS	-					615.00				1			
S-04	20+95.72	79.15' LT	COS	-					612.80				1			
S-05	21+39.46	33.00' LT	COS	638.00			632.90		632.90			623.00			1	
S-06	21+49.75	23.15' LT	FL	637.91								633.37				1
S-07	21+49.17	22.80' RT	FL	637.92				633.74								1
S-08	21+62.23	42.11' LT	FL	636.89	633.42											1
S-09	21+86.24	41.88' LT	FL	636.92		633.48			633.55					1		
S-10	21+98.15	22.37' LT	FL	637.54								633.79				1
<b>TOTAL</b>													2	2	1	5

**PROPOSED DRAINAGE PIPE SCHEDULE**

PIPE	UPSTREAM STRUCTURE	DOWNSTREAM STRUCTURE	UPSTREAM INVERT ELEVATION	DOWNSTREAM INVERT ELEVATION	PIPE SLOPE (%)	TRENCH BACKFILL	PIPE CULVERTS, CLASS A, TYPE 2 24"	STORM SEWERS, CLASS A, TYPE 1 12"	STORM SEWERS, CLASS A, TYPE 2 12"	STORM SEWERS, TYPE 1, WATER MAIN QUALITY PIPE, 12"	STORM SEWERS, TYPE 2, WATER MAIN QUALITY PIPE, 12"
						CU YD	FOOT	FOOT	FOOT	FOOT	FOOT
P-01	S-01	S-02	633.07	631.87	3.0%	13				40	
P-02	S-02	S-03	629.74	615.00	20.1%	0			73.5		
P-03	N/A	N/A	613.00	612.00	0.8%	0	131				
P-04	S-05	S-04	623.00	612.80	15.9%	0					64
P-05	S-06	S-05	633.37	632.90	3.6%	4				13	
P-06	S-07	S-05	633.74	632.90	1.5%	38		55			
P-07	S-08	EX MH	633.42	633.33	1.0%	2		9			
P-08	S-09	EX MH	633.48	633.33	1.0%	3		15			
P-09	S-10	S-09	633.79	633.55	1.0%	4		24			
<b>TOTAL</b>						64	131	103	74	53	64

MODEL: Default  
 FILE: W:\a\p\proj\trans\systems\p\h\k\c\2018\CH401\4011\0022\02-Trans\systems\CAD\2018\2018\2018\Sheet09-3-Structures.DWG  
 PLOT DATE = 9/28/2022



USER NAME = mostafan  
 PLOT SCALE = 2,000' / in.  
 PLOT DATE = 9/28/2022

DESIGNED - NWM  
 DRAWN - KWM  
 CHECKED - SPF  
 DATE - 8/12/2022

REVISED -  
 REVISED -  
 REVISED -  
 REVISED -

**STATE OF ILLINOIS  
 DEPARTMENT OF TRANSPORTATION**

**WHEELER AVENUE OVER F.A.I. ROUTE 80  
 DRAINAGE AND UTILITY SCHEDULES**

SCALE: N.T.S. SHEET 2 OF 2 SHEETS STA. TO STA.

F.A.U. RTE.	SECTION	COUNTY	TOTAL SHEETS	SHEET NO.
340	FBI 80 21 STRUCTURE 9	WILL	130	35
CONTRACT NO. 62R30				
ILLINOIS FED. AID PROJECT				

**LEGEND**

- (R) STRUCTURE TO BE REMOVED
- (A) STRUCTURE TO BE ADJUSTED
- - - STORM SEWER REMOVAL
- - - PROPOSED STORM SEWER

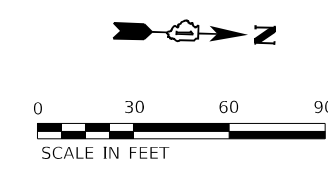
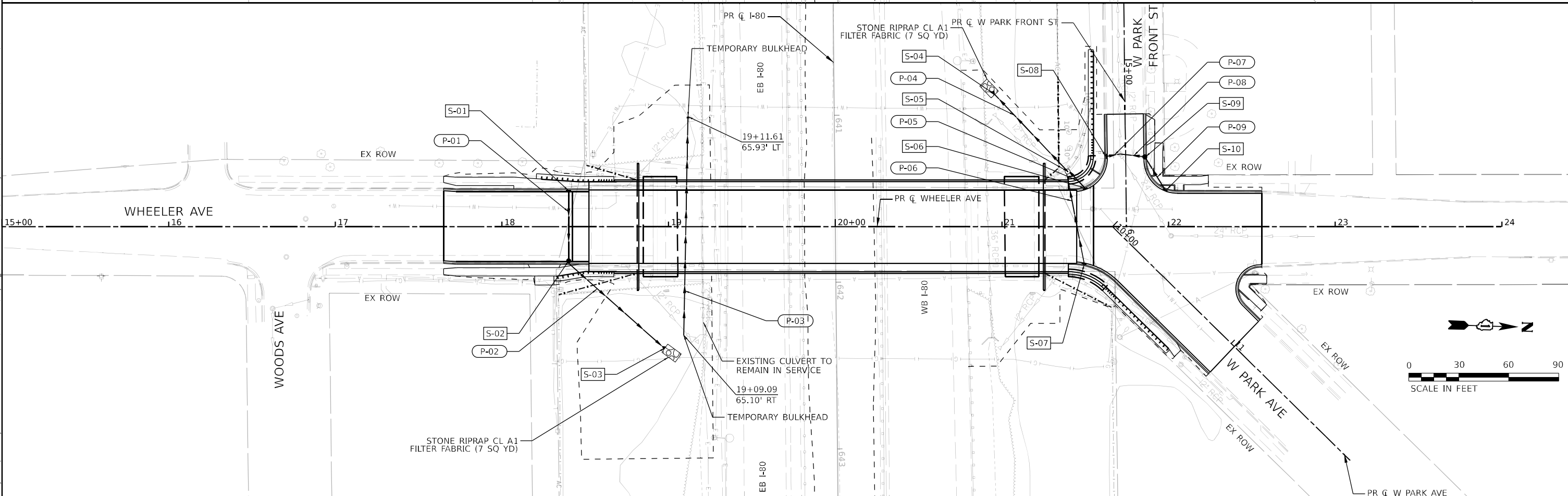
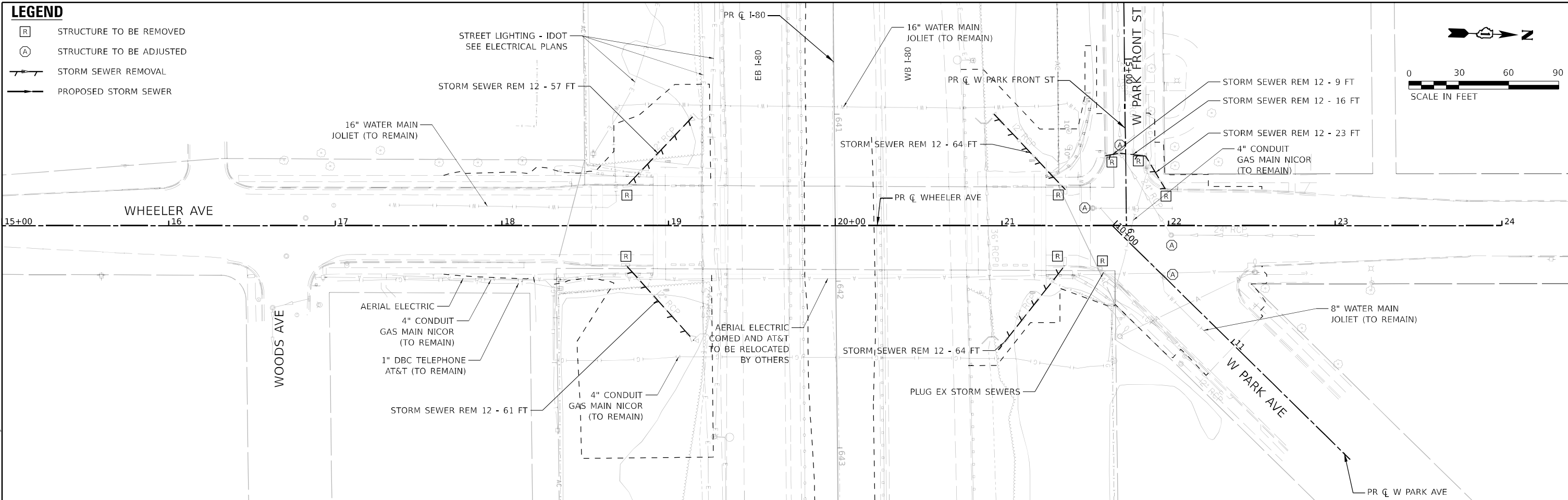
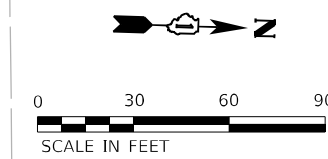

USER NAME	= mostafan
DESIGNED	- NWM
DRAWN	- KWM
PLOT SCALE	= 60,000' / in.
PLotted DATE	= 8/11/2022

REVISID	-
REVISID	-
REVISID	-
REVISID	-

**STATE OF ILLINOIS  
DEPARTMENT OF TRANSPORTATION**

**WHEELER AVENUE OVER F.A.I. ROUTE 80  
EXISTING AND PROPOSED DRAINAGE AND UTILITY PLANS**

SCALE: 1"=30'    SHEET 1 OF 1 SHEETS    STA. 15+00    TO STA. 24+00

F.A.U. RTE.	SECTION	COUNTY	TOTAL SHEETS	SHEET NO.
340	FAI 80 21 STRUCTURE 9	WILL	130	36

CONTRACT NO. 62R30  
ILLINOIS FED. AID PROJECT

MODEL: Default  
 FILE: N:\MISC\pwworkspace\mstafan\dwg\2018\CH401440\18002702\TMS\systems\cadd\62R30\Sheet13.dwg    Plotted: 8/11/2022 10:30:54 AM    PLOT SCALE: 60,000' / in.  
 MODEL: Default  
 FILE: N:\MISC\pwworkspace\mstafan\dwg\2018\CH401440\18002702\TMS\systems\cadd\62R30\Sheet13.dwg    Plotted: 8/11/2022 10:30:54 AM    PLOT SCALE: 60,000' / in.



0 30 60 90  
SCALE IN FEET

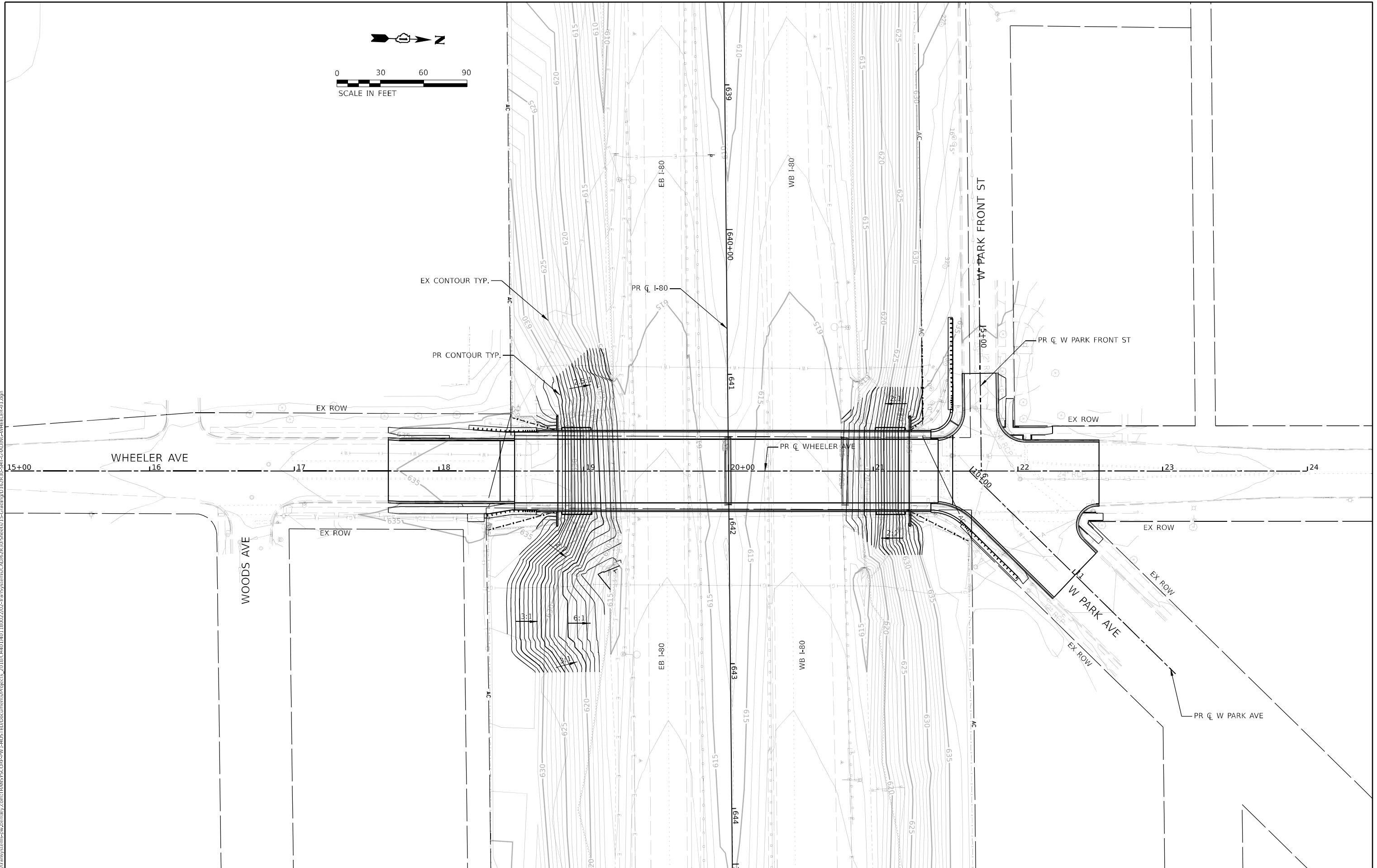

MODEL - Default  
FILE - Model.ctb  
PROJECT - I:\GIS\Projects\Transportation\Projects\2018\CH401\40110002\02\TMS\System\CAD\02\30\Sheet15-CAD\DWG\WHEELER-01.dwg



USER NAME	= mostafan	DESIGNED	- NWM	REVISED	-
DRAWN	- KWM	REVISED	-	REVISED	-
PLOT SCALE	= 60,000' / in.	CHECKED	- SPF	REVISED	-
PLOT DATE	= 8/11/2022	DATE	- 8/12/2022	REVISED	-

STATE OF ILLINOIS  
DEPARTMENT OF TRANSPORTATION

WHEELER AVENUE OVER F.A.I. ROUTE 80  
GRADING PLAN

SCALE: 1"=30'  
SHEET 1 OF 1 SHEETS  
STA. 15+00 TO STA. 24+00

F.A.U. RTE.	SECTION	COUNTY	TOTAL SHEETS	SHEET NO.
340	FAI 80 21 STRUCTURE 9	WILL	130	37
CONTRACT NO. 62R30				
ILLINOIS FED. AID PROJECT				



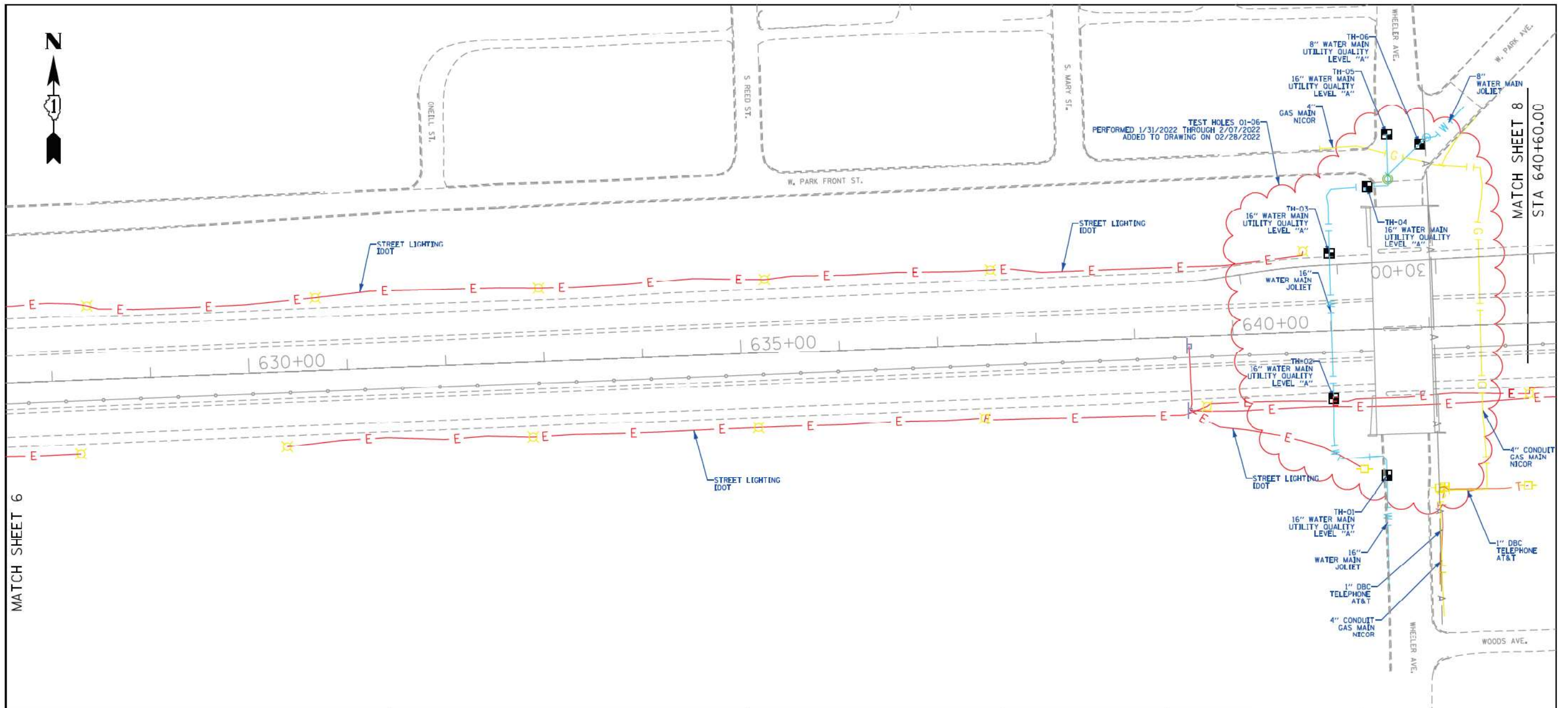

**ASCE STANDARDS OF DEPICTION OF SUBSURFACE UTILITIES**

**QUALITY LEVEL A (OLA)**  
PRECISE HORIZONTAL AND VERTICAL LOCATION OF UTILITIES OBTAINED BY THE ACTUAL EXPOSURE (OR VERIFICATION OF PREVIOUSLY EXPOSED AND SURVEYED UTILITIES) USING MINIMALLY INTRUSIVE EXCAVATION EQUIPMENT TO MINIMIZE POTENTIAL FOR UTILITY DAMAGE, AND SUBSEQUENT MEASUREMENT OF THE SUBSURFACE UTILITIES WITH OTHER UTILITY ATTRIBUTES SUCH AS TYPE, SIZE & MATERIAL OF UTILITY.

**QUALITY LEVEL B (QLB)**  
INFORMATION OBTAINED THROUGH THE APPLICATION OF APPROPRIATE SURFACE GEOPHYSICAL METHODS TO DETERMINE THE EXISTENCE AND APPROXIMATE HORIZONTAL POSITION OF SUBSURFACE UTILITIES. QUALITY LEVEL B DATA SHOULD BE REPRODUCIBLE BY SURFACE GEOPHYSICS AT ANY POINT OF THEIR DEPICTION. THIS INFORMATION IS SURVEYED TO APPLICABLE TOLERANCES DEFINED BY THE PROJECT AND REDUCED ONTO PLAN DOCUMENTS.

**QUALITY LEVEL C (OLC)**  
INFORMATION OBTAINED BY SURVEYING AND PLOTTING VISIBLE ABOVE-GROUND UTILITY FEATURES AND BY USING PROFESSIONAL JUDGEMENT IN CORRELATING THIS INFORMATION TO QUALITY LEVEL D INFORMATION.

**QUALITY LEVEL D (OLD)**  
INFORMATION DERIVED FROM EXISTING RECORDS OR ORAL RECOLLECTIONS.

**GENERAL NOTES:**

WGI INC. HAS EXERCISED ITS BEST PROFESSIONAL EXPERTISE AND GEOPHYSICAL PROSPECTING TECHNIQUES TO DEVELOP THIS MAPPING OF SUBSURFACE UTILITIES WITHIN THE PROJECT LIMITS.

WGI INC. DOES NOT GUARANTEE THAT UTILITIES SHOWN COMPRISE ALL UTILITIES WITHIN THE PROJECT AREA.

WGI'S FIELD INVESTIGATION WAS PERFORMED 10/04/19 THROUGH 03/20/20. CHANGES TO UTILITIES AFTER 03/20/20 MAY HAVE BEEN MADE AND THEREFORE MAY RESULT IN VARIANCES FROM THIS PLAN IF DEEMED ADVISABLE PRIOR TO FINAL DESIGN AND CONSTRUCTION.

FIELD LOCATED UTILITIES MEET THE FEDERAL HIGHWAY ADMINISTRATION DEFINITION FOR "QUALITY LEVEL B" (QLB) STANDARDS.

ALL UTILITIES SHOWN ARE QUALITY LEVEL B (QLB) UNLESS NOTED OTHERWISE.

WGI PROJECT #3440.13, 3440.14 & 7522.01

REVISION 1 - SHEET 7 UPDATED WITH QUALITY LEVEL A (OLA) DATA. TEST HOLES PERFORMED 1/31/2022 THROUGH 2/07/2022.

**UTILITY LEGEND:**

- A — - AERIAL
- O — - UNKNOWN UTILITY
- O — - OIL
- CTV — - CABLE TV
- T — - TELEPHONE
- G — - GAS
- E — - ELECTRIC
- E — - TRAFFIC SIGNAL/LIGHTING
- W — - WATER
- FO — - FIBER OPTIC
- FO — - FORCE MAIN
- FO — - FIBER OPTIC
- - TEST HOLE
- EOI - END OF INFORMATION
- ED - ELECTRONIC DEPTH

JOHN J. BELLIS  
062-044796  
REGISTERED PROFESSIONAL ENGINEER OF ILLINOIS  
*John J. Bellis*  
signature  
03/02/2022  
date  
License Expires 11/30/2023

**AMERICAN SURVEYING & ENGINEERING, P.C.**  
American Surveying & Engineering, P.C.  
30 N. LaSalle St., Suite 3440  
Chicago, IL 60602  
Phone No. (312) 277-2000

**Accurate GROUP, INC.**  
Accurate Group, Inc.  
101 Schekter Road, Suite 200b  
Lincolnshire, IL 60069  
Phone No. (847) 613-1100

**WGL**  
2001 Butterfield Road, Suite 410  
Downers Grove, IL 60515  
Phone No. (630) 307-3800  
Fax No. (630) 307-7030  
Cert No. 6091 - LB No. 7055

USER NAME = EickMabeza	DESIGNED -	REVISED -	REVISION 1 - 02/28/22
	DRAWN - EM	REVISED -	
PLOT SCALE = 100,0000' / in.	CHECKED - EG	REVISED -	
PLOT DATE = 3/3/2022	DATE -	REVISED -	

**STATE OF ILLINOIS DEPARTMENT OF TRANSPORTATION**

I-80 LARKIN TO WATER ST. JOLIET, ILLINOIS

SCALE: SHEET OF SHEETS STA. TO STA.

RTE.	SECTION	COUNTY	TOTAL SHEETS	SHEET NO.
CONTRACT NO. 62R30				
ILLINOIS FED. AID PROJECT				

MODEL Default FILE: \\wgi\pc\pwworkspace\pwworkspace\2018\CH40014001\10002702\Task\Systems\CD\402R30\Sheet15-Corridor\WHEELER-01.dgn

<b>AECOM</b>	USER NAME = mostafan	DESIGNED - NWM	REVISED -
		DRAWN - KWM	REVISED -
	PLOT SCALE = 60,000' / in.	CHECKED - SPF	REVISED -
	PLOT DATE = 8/10/2022	DATE - 8/12/2022	REVISED -

**STATE OF ILLINOIS DEPARTMENT OF TRANSPORTATION**

WHEELER AVENUE OVER F.A.I. ROUTE 80 UTILITY LOCATION PLAN

SCALE: SHEET 2 OF 3 SHEETS STA. TO STA.

F.A.U. RTE.	SECTION	COUNTY	TOTAL SHEETS	SHEET NO.
340	FBI 80 21 STRUCTURE 9		130	39
CONTRACT NO. 62R30				
ILLINOIS FED. AID PROJECT				

RTE.	SECTION	COUNTY	TOTAL SHEETS	SHEET NO.
CONTRACT NO. 62R30				
ILLINOIS FED. AID PROJECT				

IDOT W.O. 213, 214 & 502

MATCH SHEET 9

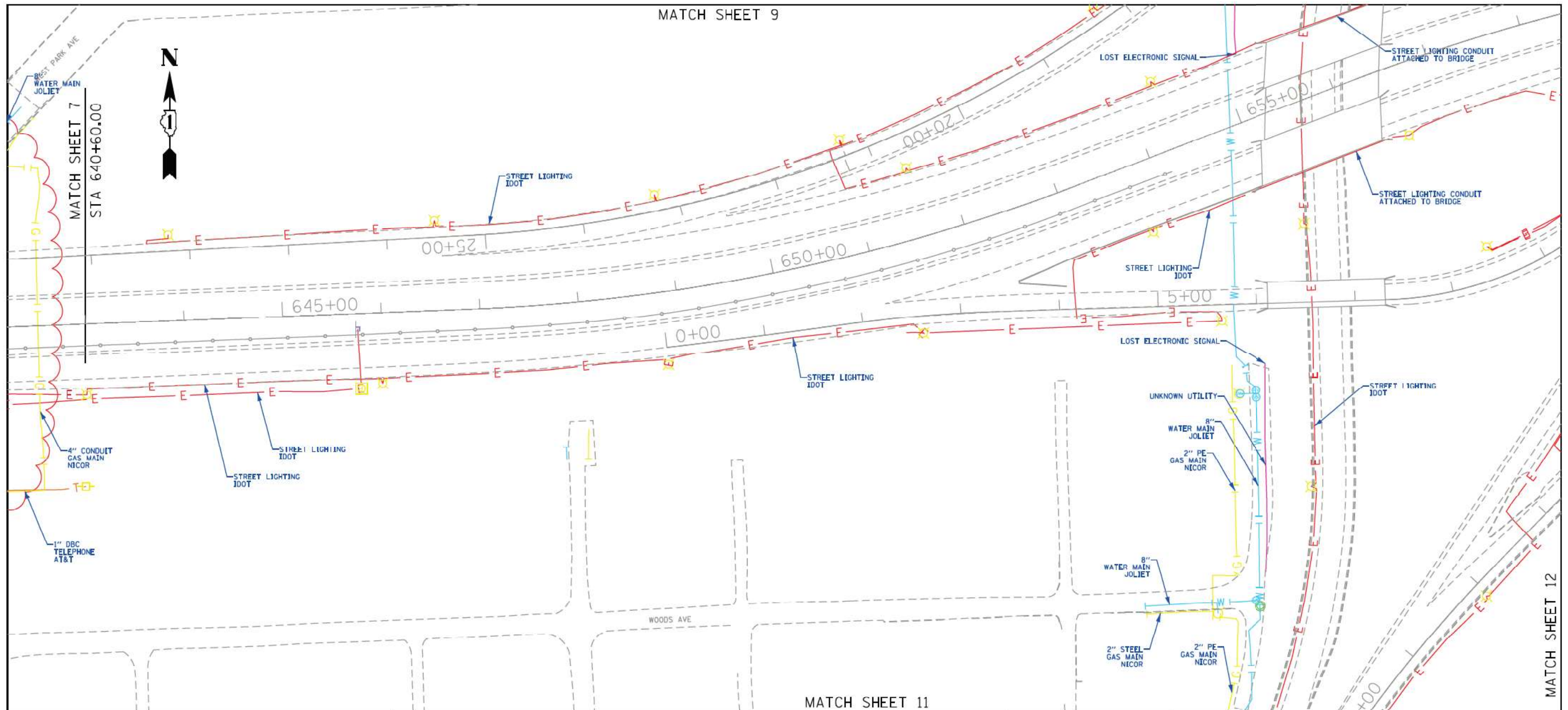

**ASCE STANDARDS OF DEPICTION OF SUBSURFACE UTILITIES**

**QUALITY LEVEL A (OLA)**  
PRECISE HORIZONTAL AND VERTICAL LOCATION OF UTILITIES OBTAINED BY THE ACTUAL EXPOSURE (OR VERIFICATION OF PREVIOUSLY EXPOSED AND SURVEYED UTILITIES) USING MINIMALLY INTRUSIVE EXCAVATION EQUIPMENT TO MINIMIZE POTENTIAL FOR UTILITY DAMAGE, AND SUBSEQUENT MEASUREMENT OF THE SUBSURFACE UTILITIES WITH OTHER UTILITY ATTRIBUTES SUCH AS TYPE, SIZE & MATERIAL OF UTILITY.

**QUALITY LEVEL B (QLB)**  
INFORMATION OBTAINED THROUGH THE APPLICATION OF APPROPRIATE SURFACE GEOPHYSICAL METHODS TO DETERMINE THE EXISTENCE AND APPROXIMATE HORIZONTAL POSITION OF SUBSURFACE UTILITIES. QUALITY LEVEL B DATA SHOULD BE REPRODUCIBLE BY SURFACE GEOPHYSICS AT ANY POINT OF THEIR DEPICTION. THIS INFORMATION IS SURVEYED TO APPLICABLE TOLERANCES DEFINED BY THE PROJECT AND REDUCED ONTO PLAN DOCUMENTS.

**QUALITY LEVEL C (OLC)**  
INFORMATION OBTAINED BY SURVEYING AND PLOTTING VISIBLE ABOVE-GROUND UTILITY FEATURES AND BY USING PROFESSIONAL JUDGEMENT IN CORRELATING THIS INFORMATION TO QUALITY LEVEL D INFORMATION.

**QUALITY LEVEL D (OLD)**  
INFORMATION DERIVED FROM EXISTING RECORDS OR ORAL RECOLLECTIONS.

**GENERAL NOTES:**

WGI INC. HAS EXERCISED ITS BEST PROFESSIONAL EXPERTISE AND GEOPHYSICAL PROSPECTING TECHNIQUES TO DEVELOP THIS MAPPING OF SUBSURFACE UTILITIES WITHIN THE PROJECT LIMITS.

WGI INC. DOES NOT GUARANTEE THAT UTILITIES SHOWN COMPRISE ALL UTILITIES WITHIN THE PROJECT AREA.

WGI'S FIELD INVESTIGATION WAS PERFORMED 10/04/19 THROUGH 03/20/20. CHANGES TO UTILITIES AFTER 03/20/20 MAY HAVE BEEN MADE AND THEREFORE MAY RESULT IN VARIANCES FROM THIS PLAN IF DEEMED ADVISABLE PRIOR TO FINAL DESIGN AND CONSTRUCTION.

FIELD LOCATED UTILITIES MEET THE FEDERAL HIGHWAY ADMINISTRATION DEFINITION FOR "QUALITY LEVEL B" (QLB) STANDARDS.

ALL UTILITIES SHOWN ARE QUALITY LEVEL B (QLB) UNLESS NOTED OTHERWISE.

WGI PROJECT #3440.13, 3440.14 & 7522.01

REVISION 1 - SHEET 7 UPDATED WITH QUALITY LEVEL A (OLA) DATA. TEST HOLES PERFORMED 1/31/2022 THROUGH 2/07/2022.

**UTILITY LEGEND:**

- AERIAL
- UNKNOWN UTILITY
- OIL
- CABLE TV
- TELEPHONE
- GAS
- ELECTRIC
- TRAFFIC SIGNAL/LIGHTING
- WATER
- FORCE MAIN
- FIBER OPTIC
- TEST HOLE
- END OF INFORMATION
- ELECTRONIC DEPTH



*John J. Bellis*  
signature  
03/02/2022  
date  
License Expires 11/30/2023

**AMERICAN**  
SURVEYING & ENGINEERING, P.C.  
American Surveying & Engineering, P.C.  
30 N. LaSalle St., Suite 3440  
Chicago, IL 60602  
Phone No. (312) 277-2000

**Accurate**  
GROUP, INC.  
Accurate Group, Inc.  
101 Schekter Road, Suite 200b  
Lincolnshire, IL 60069  
Phone No. (847) 613-1100

**WGL**  
2001 Butterfield Road, Suite 410  
Downers Grove, IL 60515  
Phone No. (630) 307-3800  
Fax No. (630) 307-7030  
Cert No. 6091 - LB No. 7055

USER NAME = Eickelmaier	DESIGNED -	REVISED -
PLOT SCALE = 100,000' / in.	DRAWN - EM	REVISED -
PLOT DATE = 3/1/2022	CHECKED - EG	REVISED -
	DATE -	REVISED -

**STATE OF ILLINOIS**  
**DEPARTMENT OF TRANSPORTATION**

**I-80 LARKIN TO WATER ST.**  
**JOLIET, ILLINOIS**

SCALE: SHEET 3 OF 3 SHEETS STA. TO STA.

RTE.	SECTION	COUNTY	TOTAL SHEETS	SHEET NO.
340	F&I 80 21 STRUCTURE 9	WILL	130	40
CONTRACT NO. 62R30				
ILLINOIS FED. AID PROJECT				

USER NAME = mostafan	DESIGNED - NWM	REVISED -
PLOT SCALE = 60,000' / in.	DRAWN - KWM	REVISED -
PLOT DATE = 8/10/2022	CHECKED - SPF	REVISED -
	DATE - 8/12/2022	REVISED -

**STATE OF ILLINOIS**  
**DEPARTMENT OF TRANSPORTATION**

**WHEELER AVENUE OVER F.A.I. ROUTE 80**  
**UTILITY LOCATION PLAN**

SCALE: SHEET 3 OF 3 SHEETS STA. TO STA.

F.A.U. RTE.	SECTION	COUNTY	TOTAL SHEETS	SHEET NO.
340	F&I 80 21 STRUCTURE 9	WILL	130	40
CONTRACT NO. 62R30				
ILLINOIS FED. AID PROJECT				

MODEL: Default  
 FILE: WHEELER\_AVE\_OVER\_F&I\_ROUTE\_80\_STRUCTURE\_9\_SHEET\_7.dwg  
 PROJECT: I-80 LARKIN TO WATER ST. JOLIET, IL  
 DATE: 3/1/2022  
 TIME: 10:00:00 AM  
 USER: mostafan



USER NAME = mostafan	DESIGNED - NWM	REVISED -
PLOT SCALE = 60,000' / in.	DRAWN - KWM	REVISED -
PLOT DATE = 8/10/2022	CHECKED - SPF	REVISED -
	DATE - 8/12/2022	REVISED -

**STATE OF ILLINOIS**  
**DEPARTMENT OF TRANSPORTATION**

**WHEELER AVENUE OVER F.A.I. ROUTE 80**  
**UTILITY LOCATION PLAN**

SCALE: SHEET 3 OF 3 SHEETS STA. TO STA.

F.A.U. RTE.	SECTION	COUNTY	TOTAL SHEETS	SHEET NO.
340	F&I 80 21 STRUCTURE 9	WILL	130	40
CONTRACT NO. 62R30				
ILLINOIS FED. AID PROJECT				



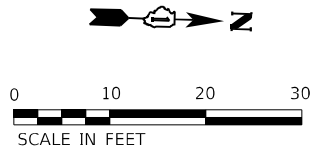

**NOTES**

1. EXISTING ELEVATIONS ARE NOTED USING PARANTHESES (XXX.XX')
2. SEE ADA DETAIL SHEETS FOR CURB RAMP DETAILS
3. STATIONS PROVIDED REFER TO PR  $\bar{C}$  WHEELER UNLESS OTHERWISE NOTED. (PF) REFERS TO  $\bar{C}$  W PARK FRONT ST. (PA) REFERS TO  $\bar{C}$  W PARK AVE. RESPECTIVELY.
4. PREFIXES PC AND PT REFER TO POINTS OF CURVATURE AND TANGENCY, RESPECTIVELY.

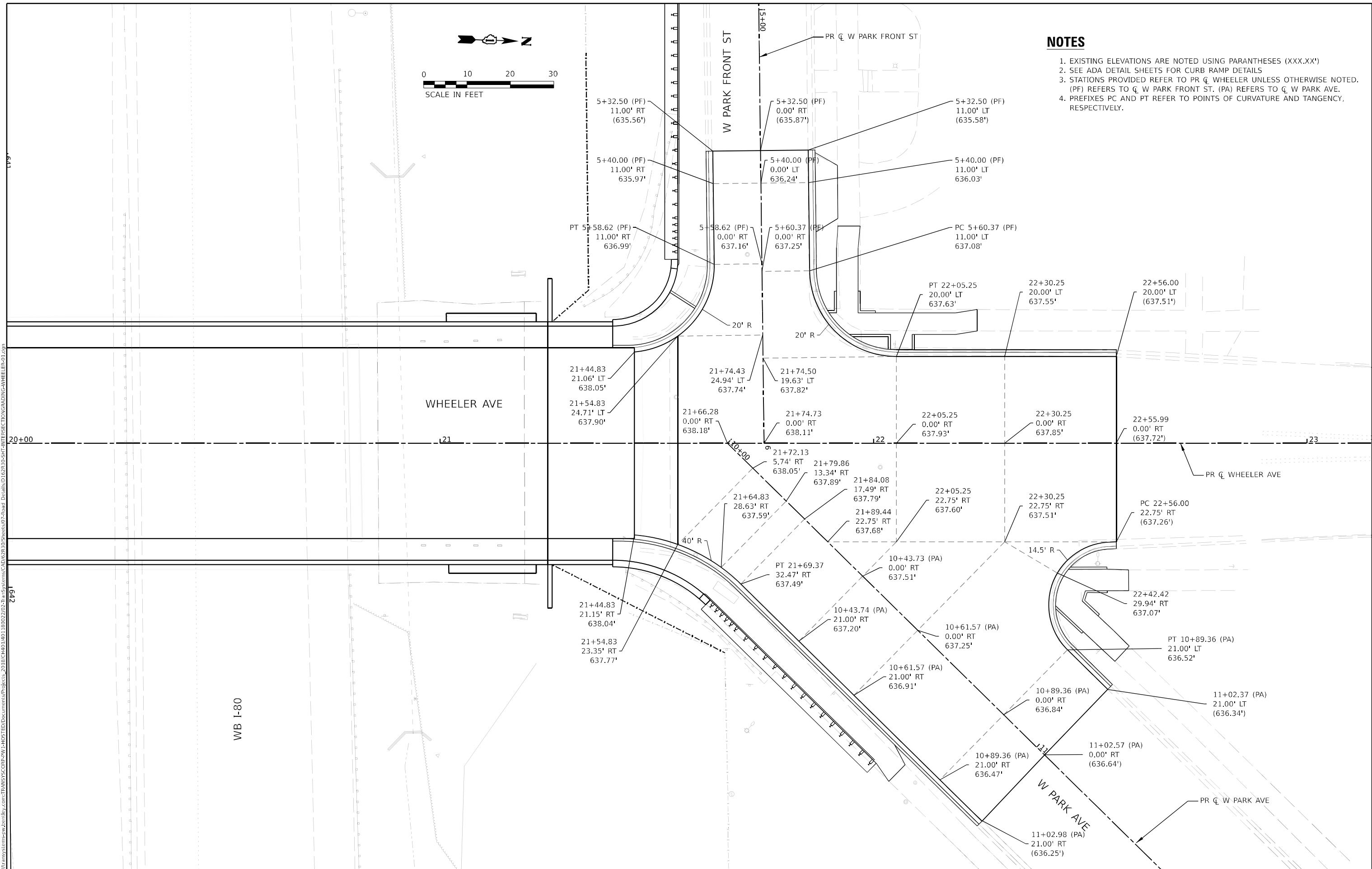

MODEL: Default  
 FILE: W:\a11\p101\trans\scorp\p11\hst\ed\Drawings\Grading\WB I-80\WB I-80 21 Structure 9.dwg  
 2018/04/01 10:02:02  
 User: kwm  
 Title: WB I-80 21 Structure 9.dwg  
 Plot Date: 8/10/2022



USER NAME = mostafan	DESIGNED - NWM	REVISED -
DRAWN - KWM	REVISED -	
PLOT SCALE = 20,000' / in.	CHECKED - SPF	REVISED -
PLOT DATE = 8/10/2022	DATE - 8/12/2022	REVISED -

**STATE OF ILLINOIS  
DEPARTMENT OF TRANSPORTATION**

<b>WHEELER AVENUE OVER F.A.I. ROUTE 80 INTERSECTION GRADING DETAILS</b>	
SCALE: 1"=10'	SHEET 1 OF 1 SHEETS
STA. 20+00	TO STA. 22+83

F.A.U. RTE.	SECTION	COUNTY	TOTAL SHEETS	SHEET NO.
340	FAI 80 21 STRUCTURE 9	WILL	130	41
CONTRACT NO. 62R30				
ILLINOIS FED. AID PROJECT				

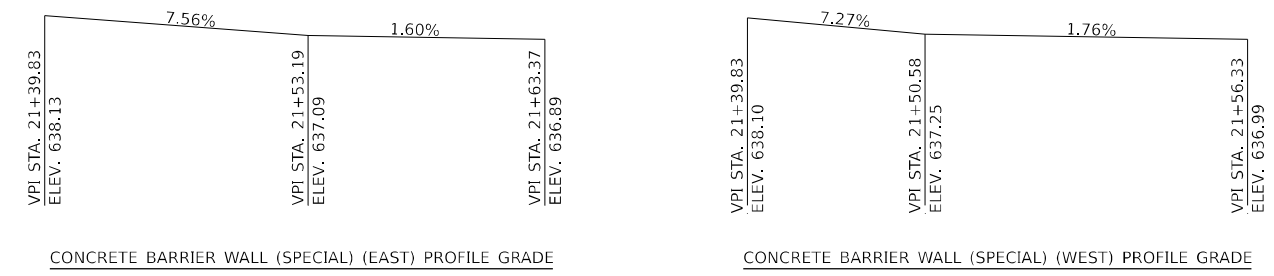
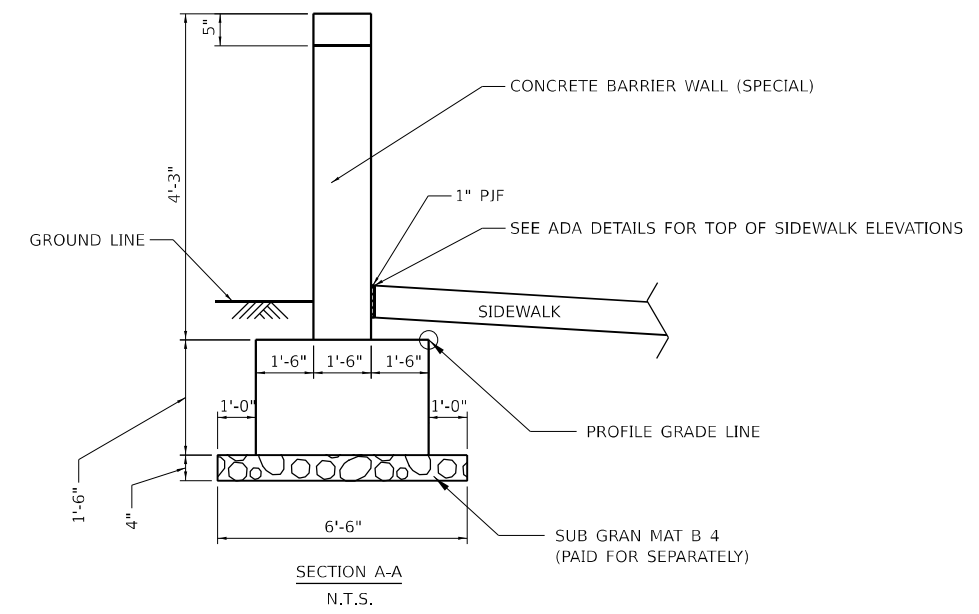
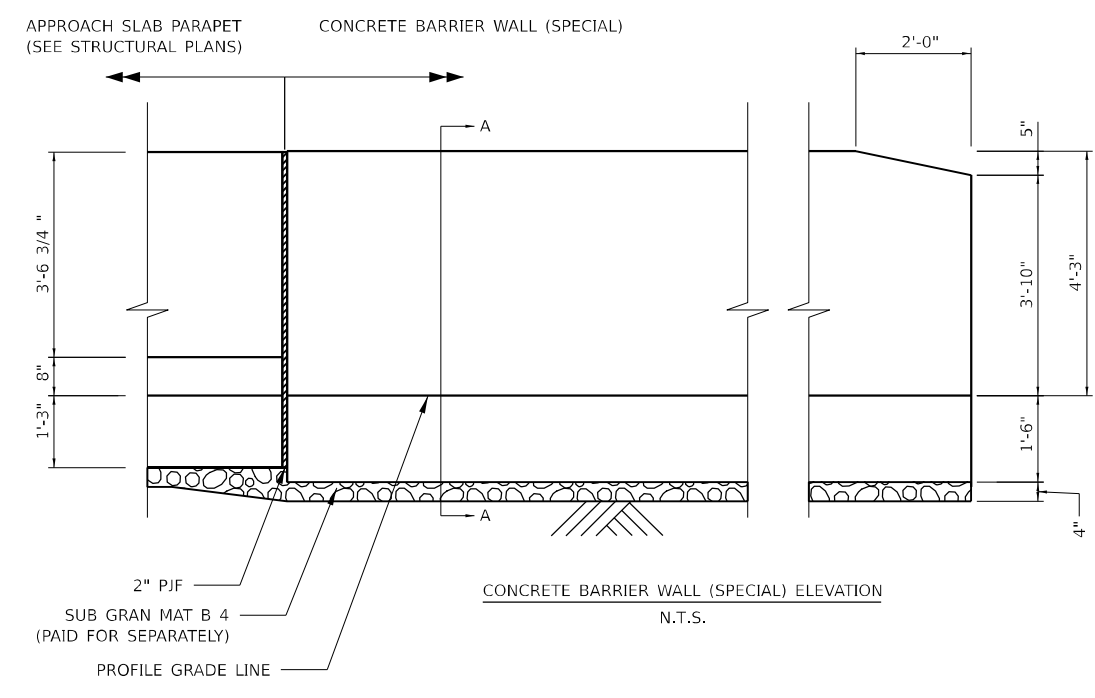
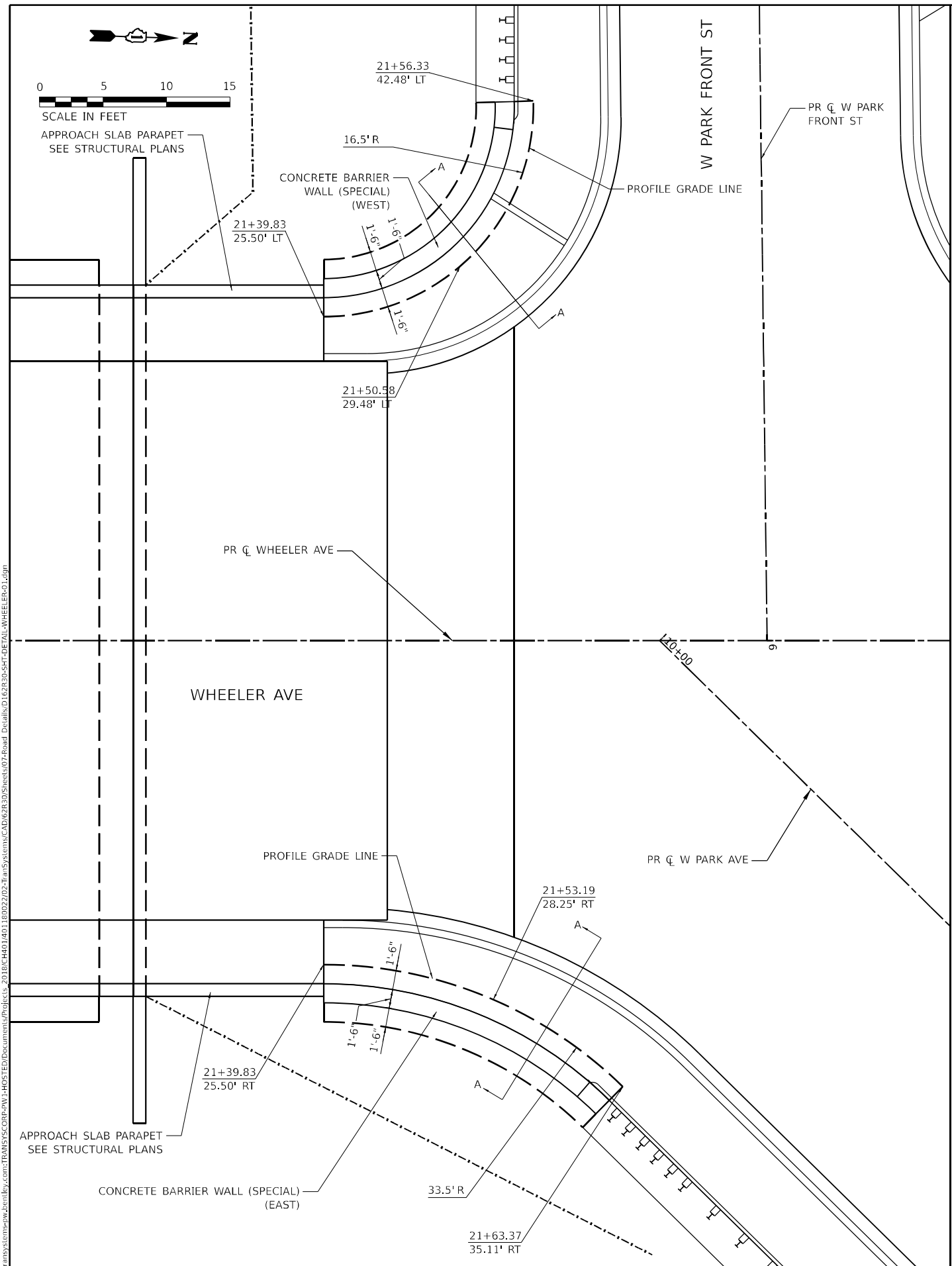

MODEL: Defaul  
 FILE: \\pwr\pwr\mssys\comp\pwr\pwr\pwr\comp\TRANS\SCORP\PROJ\100027\02-21\mssys\comp\CAD\02\03\Sheet\07-Road\_Details\01\02\03\04\05\06\07\08\09\10\11\12\13\14\15\16\17\18\19\20\21\22\23\24\25\26\27\28\29\30\31\32\33\34\35\36\37\38\39\40\41\42\43\44\45\46\47\48\49\50\51\52\53\54\55\56\57\58\59\60\61\62\63\64\65\66\67\68\69\70\71\72\73\74\75\76\77\78\79\80\81\82\83\84\85\86\87\88\89\90\91\92\93\94\95\96\97\98\99\100\101\102\103\104\105\106\107\108\109\110\111\112\113\114\115\116\117\118\119\120\121\122\123\124\125\126\127\128\129\130\131\132\133\134\135\136\137\138\139\140\141\142\143\144\145\146\147\148\149\150\151\152\153\154\155\156\157\158\159\160\161\162\163\164\165\166\167\168\169\170\171\172\173\174\175\176\177\178\179\180\181\182\183\184\185\186\187\188\189\190\191\192\193\194\195\196\197\198\199\200\201\202\203\204\205\206\207\208\209\210\211\212\213\214\215\216\217\218\219\220\221\222\223\224\225\226\227\228\229\230\231\232\233\234\235\236\237\238\239\240\241\242\243\244\245\246\247\248\249\250\251\252\253\254\255\256\257\258\259\260\261\262\263\264\265\266\267\268\269\270\271\272\273\274\275\276\277\278\279\280\281\282\283\284\285\286\287\288\289\290\291\292\293\294\295\296\297\298\299\300\301\302\303\304\305\306\307\308\309\310\311\312\313\314\315\316\317\318\319\320\321\322\323\324\325\326\327\328\329\330\331\332\333\334\335\336\337\338\339\340\341\342\343\344\345\346\347\348\349\350\351\352\353\354\355\356\357\358\359\360\361\362\363\364\365\366\367\368\369\370\371\372\373\374\375\376\377\378\379\380\381\382\383\384\385\386\387\388\389\390\391\392\393\394\395\396\397\398\399\400\401\402\403\404\405\406\407\408\409\410\411\412\413\414\415\416\417\418\419\420\421\422\423\424\425\426\427\428\429\430\431\432\433\434\435\436\437\438\439\440\441\442\443\444\445\446\447\448\449\450\451\452\453\454\455\456\457\458\459\460\461\462\463\464\465\466\467\468\469\470\471\472\473\474\475\476\477\478\479\480\481\482\483\484\485\486\487\488\489\490\491\492\493\494\495\496\497\498\499\500\501\502\503\504\505\506\507\508\509\510\511\512\513\514\515\516\517\518\519\520\521\522\523\524\525\526\527\528\529\530\531\532\533\534\535\536\537\538\539\540\541\542\543\544\545\546\547\548\549\550\551\552\553\554\555\556\557\558\559\560\561\562\563\564\565\566\567\568\569\570\571\572\573\574\575\576\577\578\579\580\581\582\583\584\585\586\587\588\589\590\591\592\593\594\595\596\597\598\599\600\601\602\603\604\605\606\607\608\609\610\611\612\613\614\615\616\617\618\619\620\621\622\623\624\625\626\627\628\629\630\631\632\633\634\635\636\637\638\639\640\641\642\643\644\645\646\647\648\649\650\651\652\653\654\655\656\657\658\659\660\661\662\663\664\665\666\667\668\669\670\671\672\673\674\675\676\677\678\679\680\681\682\683\684\685\686\687\688\689\690\691\692\693\694\695\696\697\698\699\700\701\702\703\704\705\706\707\708\709\710\711\712\713\714\715\716\717\718\719\720\721\722\723\724\725\726\727\728\729\730\731\732\733\734\735\736\737\738\739\740\741\742\743\744\745\746\747\748\749\750\751\752\753\754\755\756\757\758\759\760\761\762\763\764\765\766\767\768\769\770\771\772\773\774\775\776\777\778\779\780\781\782\783\784\785\786\787\788\789\790\791\792\793\794\795\796\797\798\799\800\801\802\803\804\805\806\807\808\809\810\811\812\813\814\815\816\817\818\819\820\821\822\823\824\825\826\827\828\829\830\831\832\833\834\835\836\837\838\839\840\841\842\843\844\845\846\847\848\849\850\851\852\853\854\855\856\857\858\859\860\861\862\863\864\865\866\867\868\869\870\871\872\873\874\875\876\877\878\879\880\881\882\883\884\885\886\887\888\889\890\891\892\893\894\895\896\897\898\899\900\901\902\903\904\905\906\907\908\909\910\911\912\913\914\915\916\917\918\919\920\921\922\923\924\925\926\927\928\929\930\931\932\933\934\935\936\937\938\939\940\941\942\943\944\945\946\947\948\949\950\951\952\953\954\955\956\957\958\959\960\961\962\963\964\965\966\967\968\969\970\971\972\973\974\975\976\977\978\979\980\981\982\983\984\985\986\987\988\989\990\991\992\993\994\995\996\997\998\999\1000



USER NAME = mostafan	DESIGNED - NWM	REVISED -
DRAWN - KWM	REVISED -	
PLOT SCALE = 10,000' / in.	CHECKED - SPF	REVISED -
PLOT DATE = 8/11/2022	DATE - 8/12/2022	REVISED -

**STATE OF ILLINOIS  
DEPARTMENT OF TRANSPORTATION**

**WHEELER AVENUE OVER F.A.I. ROUTE 80  
ROADWAY DETAILS – CONCRETE BARRIER WALL, SPECIAL**

SCALE: 1"=5' SHEET 1 OF 2 SHEETS STA. TO STA.

F.A.U. RTE.	SECTION	COUNTY	TOTAL SHEETS	SHEET NO.
340	FAI 80 21 STRUCTURE 9	WILL	130	42
CONTRACT NO. 62R30				
ILLINOIS FED. AID PROJECT				

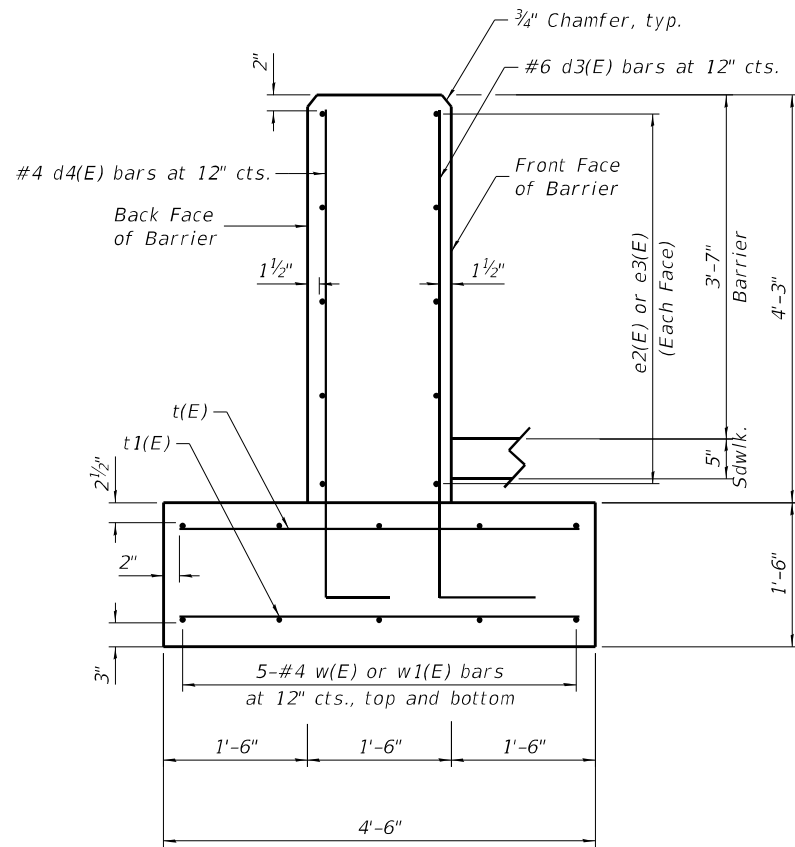

**CONCRETE BARRIER WALL, SPECIAL- WEST  
CROSS SECTION**

(Scale: 1" = 1'-0")

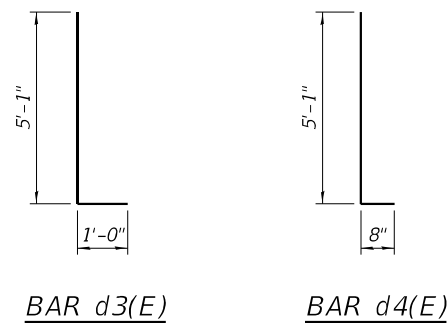

**BILL OF MATERIAL**

Bar	No.	Size	Length	Shape
d3(E)	51	#6	6'-1"	┌───┐
d4(E)	51	#4	5'-9"	┌───┐
e2(E)	10	#4	23'-8"	───
e3(E)	10	#4	24'-7"	───
t(E)	51	#6	4'-2"	───
t1(E)	51	#4	4'-2"	───
w(E)	10	#4	23'-8"	───
w1(E)	10	#4	24'-7"	───
Concrete Barrier Wall (Special)		Foot	49	
Reinforcement Bars, Epoxy Coated		Pound	1,770	

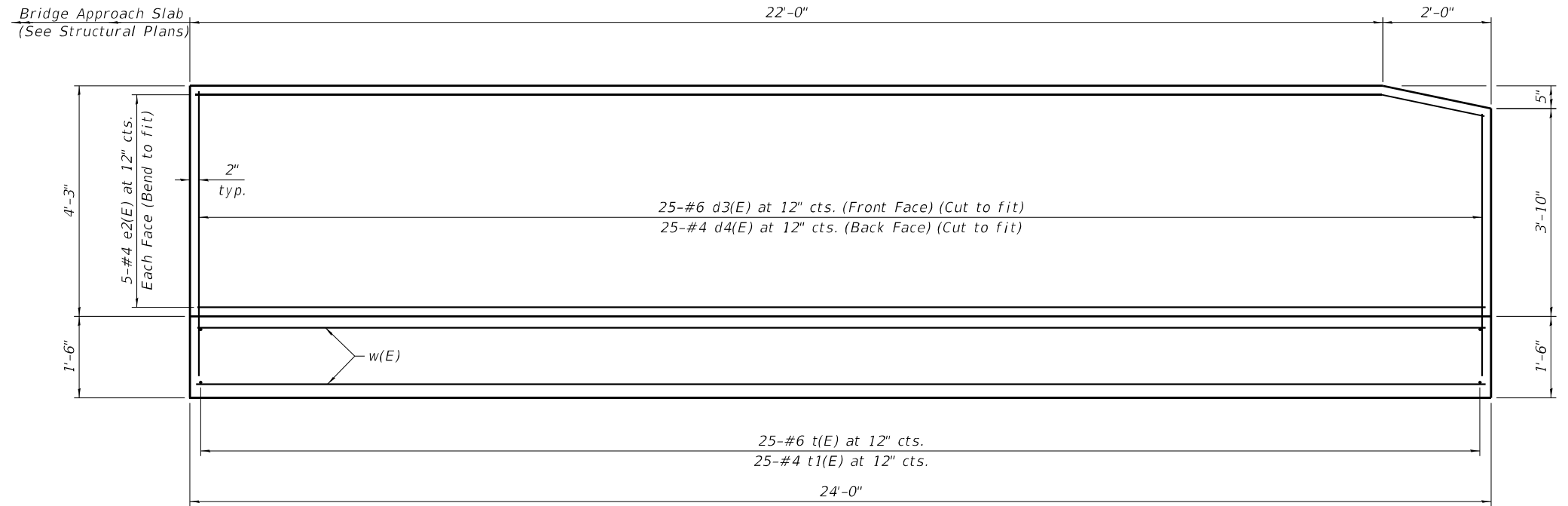

**CONCRETE BARRIER WALL, SPECIAL- WEST  
ELEVATION ALONG FRONT FACE OF BARRIER**

(Scale: 3/4" = 1'-0")

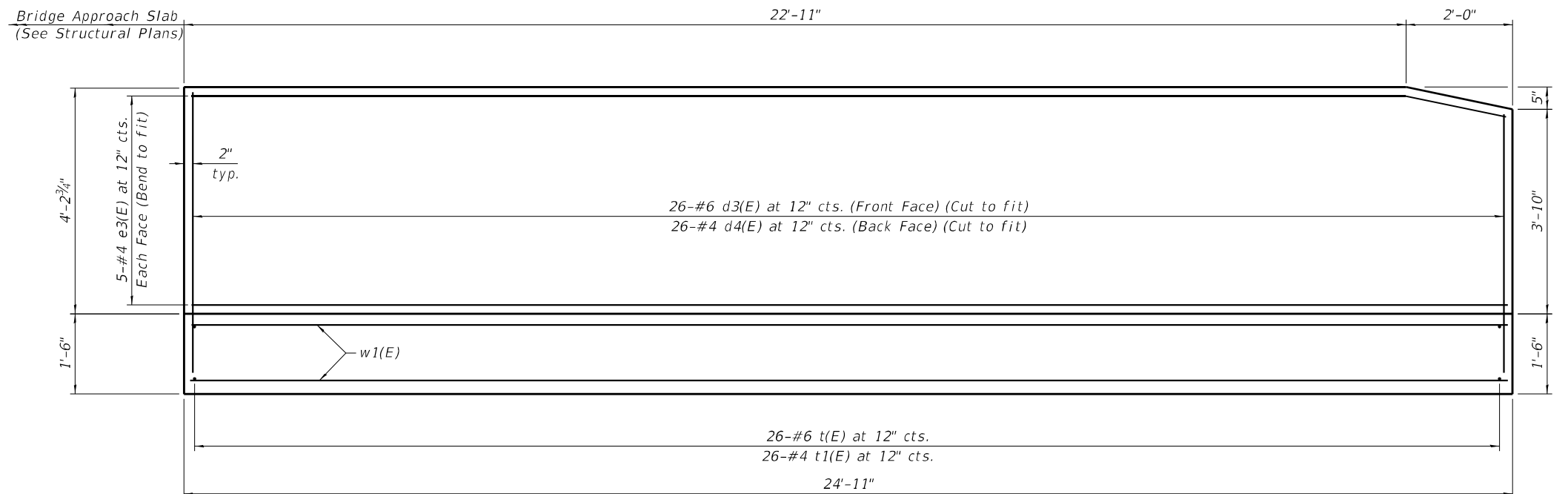

**CONCRETE BARRIER WALL, SPECIAL- EAST  
ELEVATION ALONG FRONT FACE OF BARRIER**

(Scale: 3/4" = 1'-0")

MODEL - Sheet  
 FILE - WHEELER\_AVE\_Plan\_01.dwg  
 PROJECT - WHEELER AVENUE OVER F.A.I. ROUTE 80  
 DRAWING - ROADWAY DETAILS - CONCRETE BARRIER WALL, SPECIAL  
 SHEET - 130 OF 130  
 DATE - 8/11/2022  
 DRAWN BY - DD  
 CHECKED BY - MK  
 DESIGNED BY - MK  
 REVISIONS -  
 SCALE - 1/4" = 1'-0"  
 PLOT DATE - 8/11/2022



USER NAME = mostafan  
 PLOT SCALE = 0:2 1/4" / in.  
 PLOT DATE = 8/11/2022

DESIGNED - MK  
 DRAWN - DD  
 CHECKED - MK  
 DATE - 8/12/2022

REVISED -  
 REVISED -  
 REVISED -  
 REVISED -

**STATE OF ILLINOIS  
DEPARTMENT OF TRANSPORTATION**

**WHEELER AVENUE OVER F.A.I. ROUTE 80  
ROADWAY DETAILS - CONCRETE BARRIER WALL, SPECIAL**

SCALE: SHEET 2 OF 2 SHEETS STA. TO STA.

F.A.U. RTE.	SECTION	COUNTY	TOTAL SHEETS	SHEET NO.
340	FBI 80 21 STRUCTURE 9	WILL	130	43
CONTRACT NO. 62R30			ILLINOIS FED. AID PROJECT	

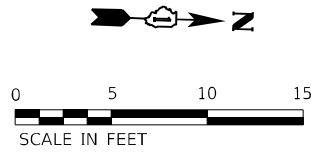

**SOUTHWEST RAMPS**

POINT	STATION	OFFSET (FT)	RT/LT	ELEV (FT)
A	21+43.59	27.48'	LT	638.56'
B	21+49.85	30.84'	LT	637.98'
C	21+52.99	34.79'	LT	637.89'
D	21+44.08	22.60'	LT	638.48'
E	21+54.09	26.12'	LT	637.88'
F	21+55.02	24.84'	LT	637.90'
G	21+60.10	30.25'	LT	637.79'
H	21+58.77	31.11'	LT	637.78'

ALL STATIONING AND OFFSETS REFER TO CL WHEELER AVE.

**NORTHWEST RAMPS**

POINT	STATION	OFFSET (FT)	RT/LT	ELEV (FT)
A	21+96.45	40.08'	LT	637.36'
B	21+96.45	35.08'	LT	637.47'
C	21+96.45	30.08'	LT	637.58'
D	22+00.45	30.08'	LT	637.86'
E	22+03.92	30.08'	LT	637.91'
F	22+08.92	30.08'	LT	637.98'
G	22+13.92	30.08'	LT	638.10'
H	22+18.92	30.08'	LT	638.00'
I	21+91.45	40.08'	LT	637.28'
J	21+91.45	35.08'	LT	637.39'
K	21+89.73	30.08'	LT	637.54'
L	21+87.88	30.08'	LT	637.54'
M	21+93.52	23.80'	LT	637.58'
N	21+94.45	25.08'	LT	637.57'
O	21+95.31	22.65'	LT	637.59'
P	22+00.45	25.08'	LT	637.80'
Q	22+03.92	25.08'	LT	637.84'
R	22+03.92	21.63'	LT	637.62'
S	22+03.92	20.04'	LT	637.63'
T	22+08.92	20.00'	LT	637.62'
U	22+08.92	21.58'	LT	637.61'
V	22+08.92	25.08'	LT	637.88'
W	22+13.92	25.08'	LT	638.03'
X	22+18.92	25.08'	LT	637.93'
Y	21+96.45	25.08'	LT	637.60'

ALL STATIONING AND OFFSETS REFER TO CL WHEELER AVE.

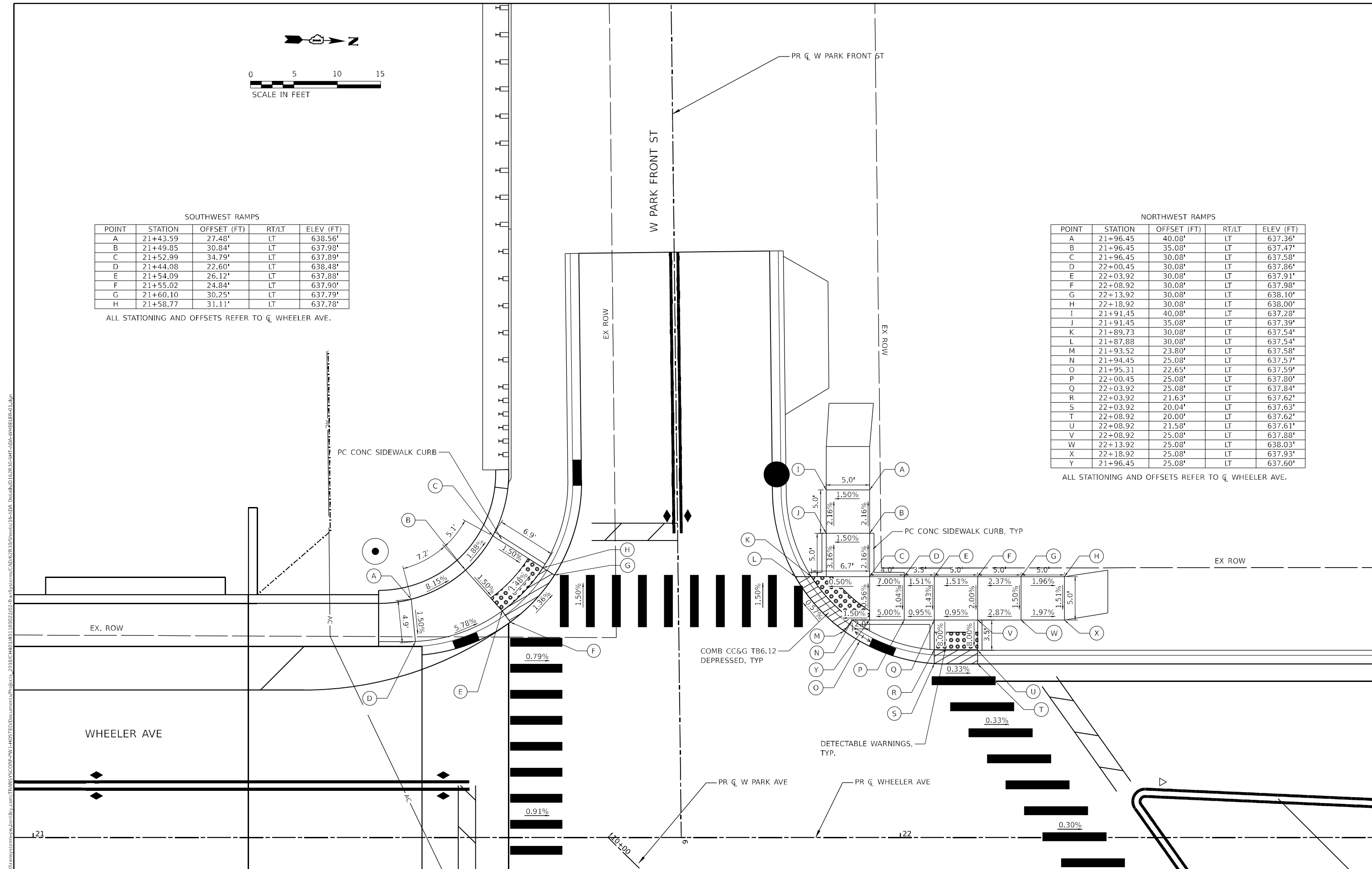

MODEL: Defaul  
 FILE: \\mspc\proj\systems\consumers\hantley\cadd\trans\scorp\pwt\hst\ED\Documents\proj\chic\_2018\CHIC4401401\10002702\T-MS\systems\consumers\hantley\cadd\trans\scorp\pwt\hst\ED\1ER3D-SHT-ADA-WHEELER-01.dgn



USER NAME = mostafan  
 PLOT SCALE = 10,000' / in.  
 PLOT DATE = 8/10/2022

DESIGNED - NWM  
 DRAWN - KWM  
 CHECKED - SPF  
 DATE - 8/12/2022

REVISED -  
 REVISED -  
 REVISED -  
 REVISED -

**STATE OF ILLINOIS  
 DEPARTMENT OF TRANSPORTATION**

**WHEELER AVENUE OVER F.A.I. ROUTE 80  
 ADA RAMP DETAILS**

SCALE: 1"=5'  
 SHEET 1 OF 2 SHEETS STA. TO STA.

F.A.U. RTE.	SECTION	COUNTY	TOTAL SHEETS	SHEET NO.
340	FBI 80 21 STRUCTURE 9	WILL	130	44
CONTRACT NO. 62R30				
ILLINOIS		FED. AID PROJECT		

MODEL - Defaul  
 FILE - WHEELER\_02122022.dwg  
 PROJECT - TRANSPORTATION  
 DRAWING - ADA RAMP DETAILS  
 DATE - 8/12/2022

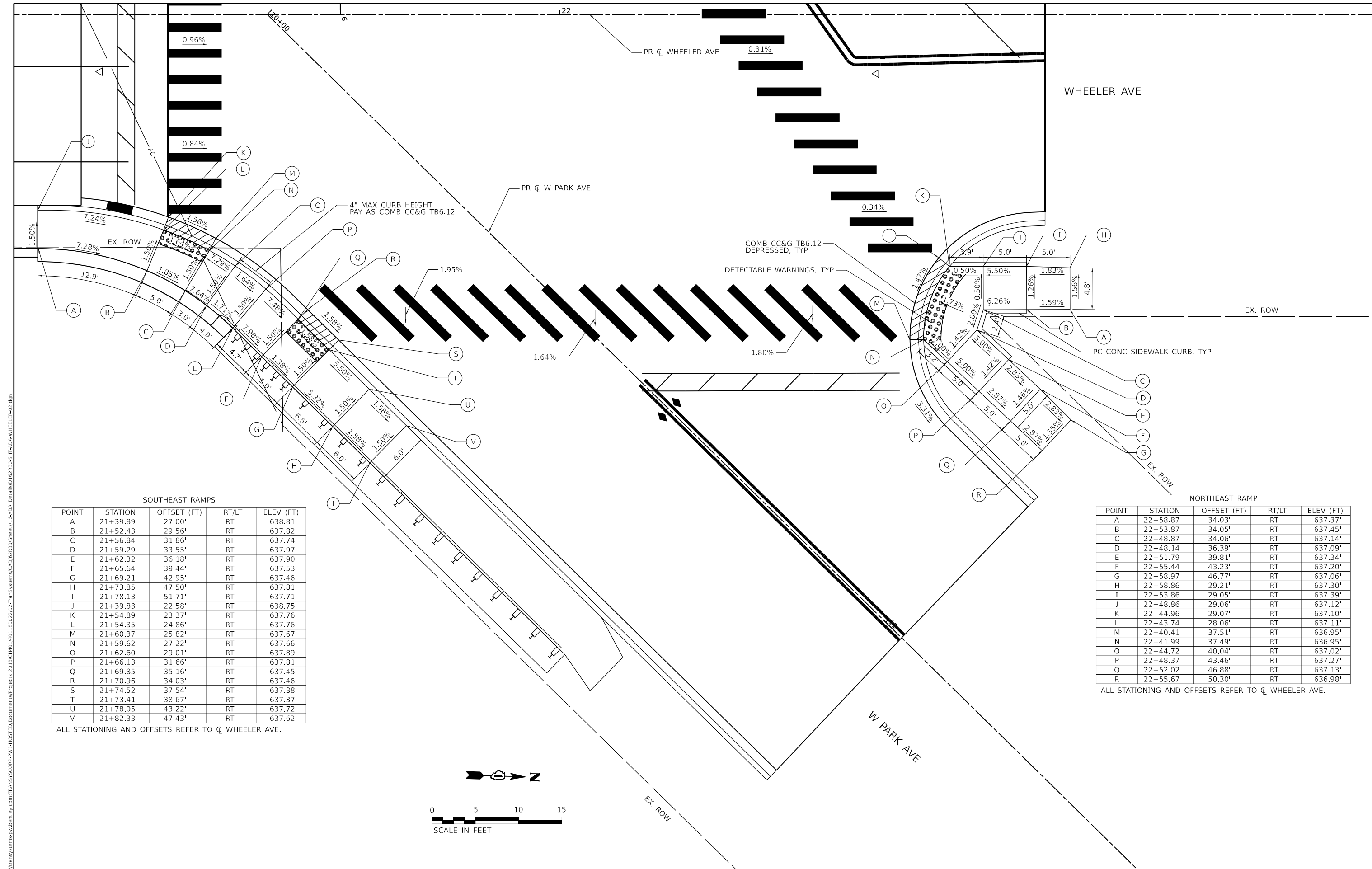

**SOUTHEAST RAMPS**

POINT	STATION	OFFSET (FT)	RT/LT	ELEV (FT)
A	21+39.89	27.00'	RT	638.81'
B	21+52.43	29.56'	RT	637.82'
C	21+56.84	31.86'	RT	637.74'
D	21+59.29	33.55'	RT	637.97'
E	21+62.32	36.18'	RT	637.90'
F	21+65.64	39.44'	RT	637.53'
G	21+69.21	42.95'	RT	637.46'
H	21+73.85	47.50'	RT	637.81'
I	21+78.13	51.71'	RT	637.71'
J	21+39.83	22.58'	RT	638.75'
K	21+54.89	23.37'	RT	637.76'
L	21+54.35	24.86'	RT	637.76'
M	21+60.37	25.82'	RT	637.67'
N	21+59.62	27.22'	RT	637.66'
O	21+62.60	29.01'	RT	637.89'
P	21+66.13	31.66'	RT	637.81'
Q	21+69.85	35.16'	RT	637.45'
R	21+70.96	34.03'	RT	637.46'
S	21+74.52	37.54'	RT	637.38'
T	21+73.41	38.67'	RT	637.37'
U	21+78.05	43.22'	RT	637.72'
V	21+82.33	47.43'	RT	637.62'

ALL STATIONING AND OFFSETS REFER TO C WHEELER AVE.

**NORTHEAST RAMP**

POINT	STATION	OFFSET (FT)	RT/LT	ELEV (FT)
A	22+58.87	34.03'	RT	637.37'
B	22+53.87	34.05'	RT	637.45'
C	22+48.87	34.06'	RT	637.14'
D	22+48.14	36.39'	RT	637.09'
E	22+51.79	39.81'	RT	637.34'
F	22+55.44	43.23'	RT	637.20'
G	22+58.97	46.77'	RT	637.06'
H	22+58.86	29.21'	RT	637.30'
I	22+53.86	29.05'	RT	637.39'
J	22+48.86	29.06'	RT	637.12'
K	22+44.96	29.07'	RT	637.10'
L	22+43.74	28.06'	RT	637.11'
M	22+40.41	37.51'	RT	636.95'
N	22+41.99	37.49'	RT	636.95'
O	22+44.72	40.04'	RT	637.02'
P	22+48.37	43.46'	RT	637.27'
Q	22+52.02	46.88'	RT	637.13'
R	22+55.67	50.30'	RT	636.98'

ALL STATIONING AND OFFSETS REFER TO C WHEELER AVE.

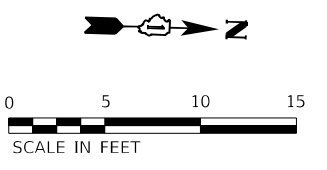

USER NAME = mostafan  
 PLOT SCALE = 10,000' / in.  
 PLOT DATE = 8/10/2022

DESIGNED - NWM  
 DRAWN - KWM  
 CHECKED - SPF  
 DATE - 8/12/2022

REVISED -  
 REVISED -  
 REVISED -  
 REVISED -

**STATE OF ILLINOIS  
 DEPARTMENT OF TRANSPORTATION**

**WHEELER AVENUE OVER F.A.I. ROUTE 80  
 ADA RAMP DETAILS**

SCALE: 1"=5'      SHEET 2 OF 2 SHEETS      STA.      TO STA.

F.A.U. RTE.	SECTION	COUNTY	TOTAL SHEETS	SHEET NO.
340	FBI 80 21 STRUCTURE 9	WILL	130	45
CONTRACT NO. 62R30				
ILLINOIS FED. AID PROJECT				



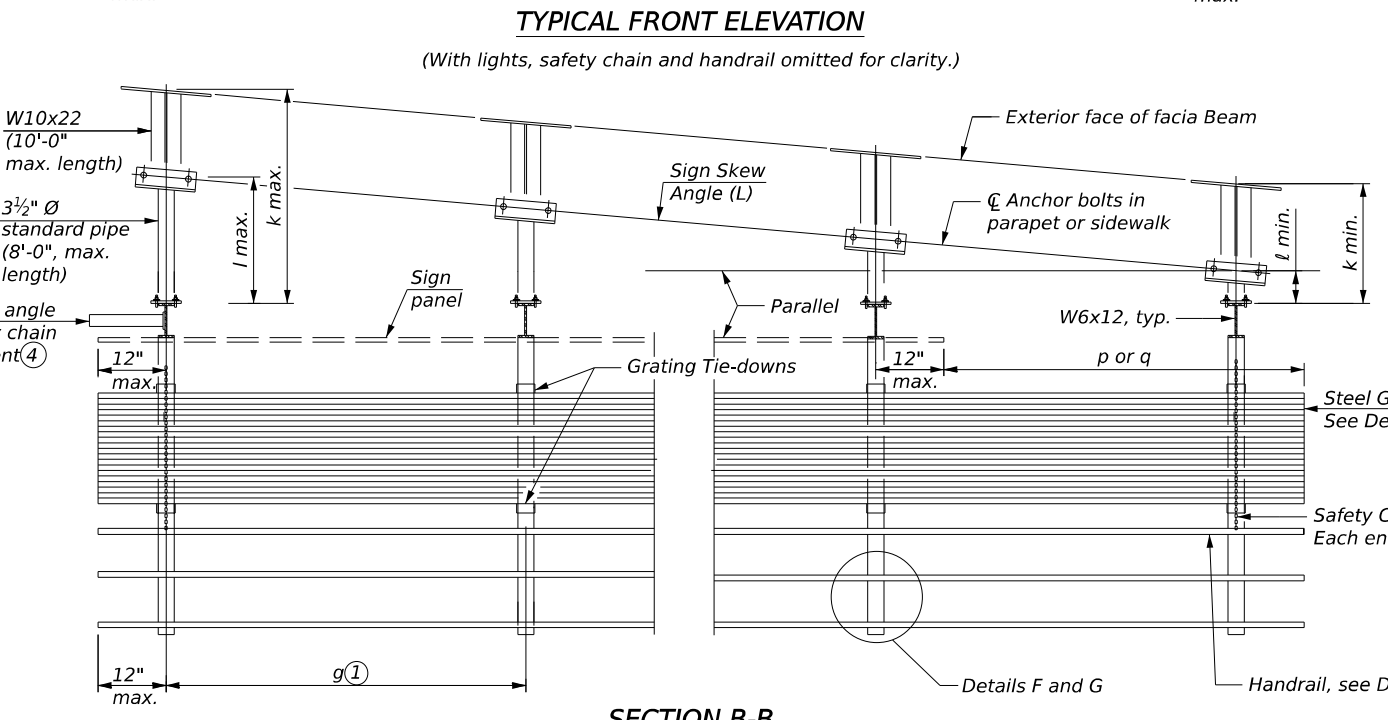
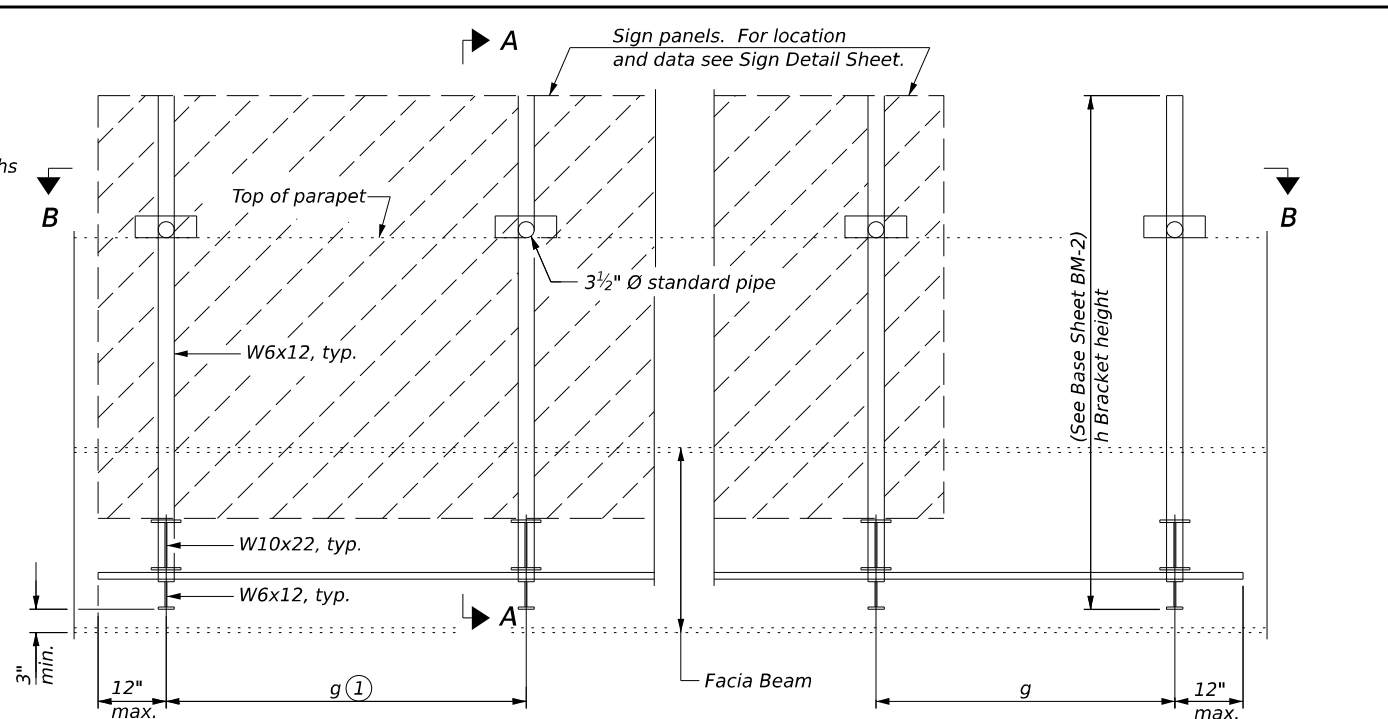
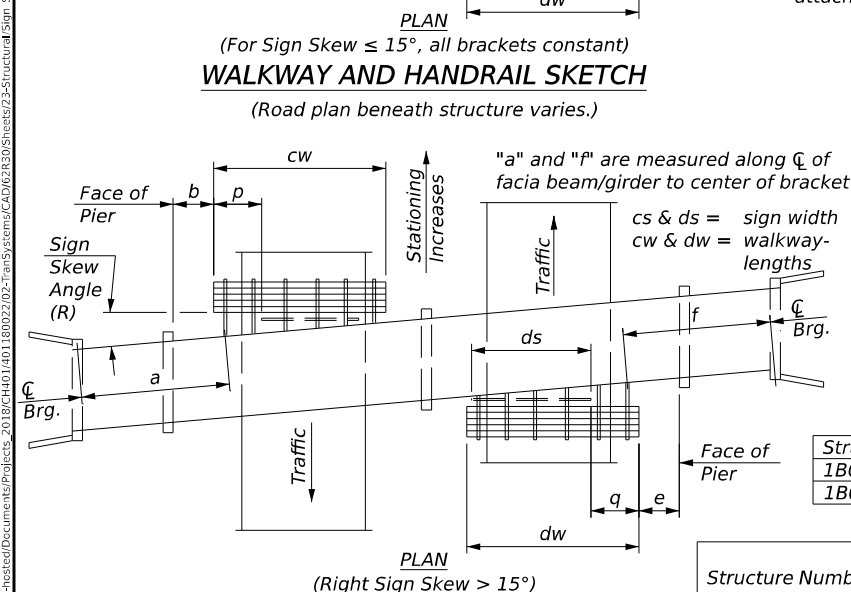
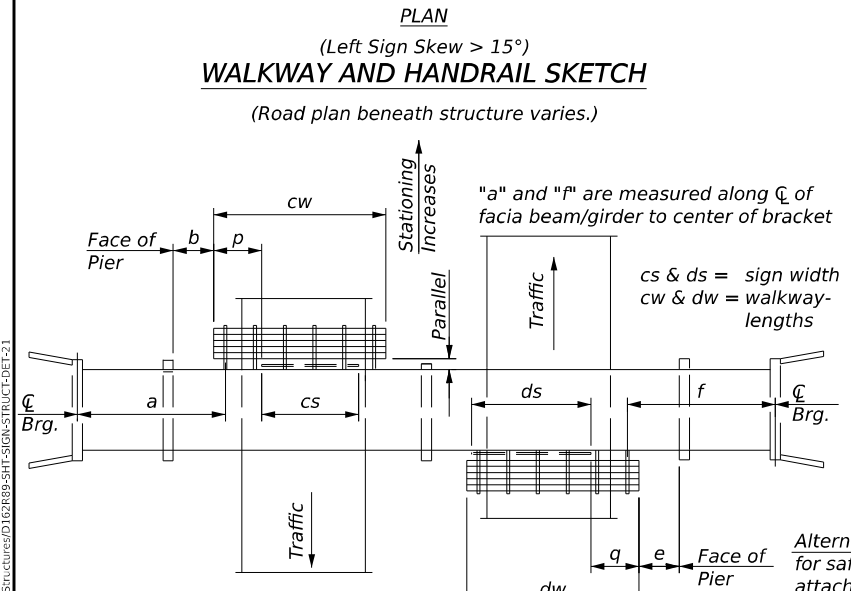
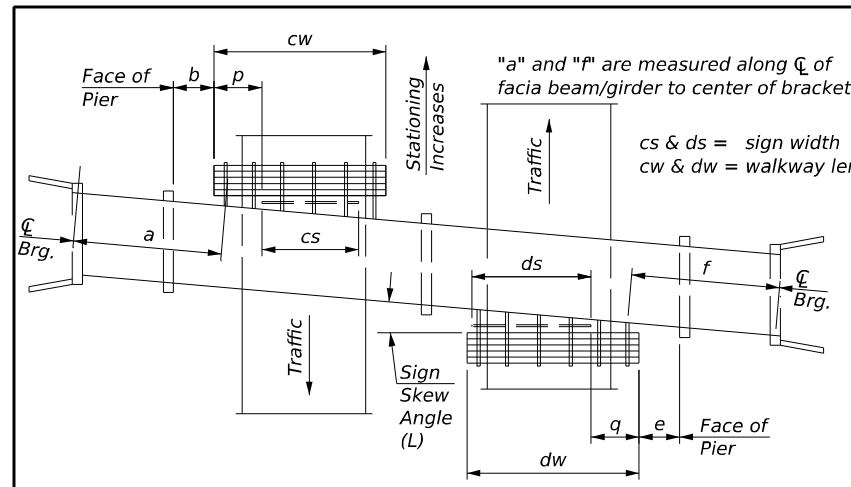

Structure Number	Bridge Name	g1	g2	g3
1B016180R131.6B	Wheeler Ave over I-80	5'-4"	3'-7"	3'-7"
1B016180L131.6C	Wheeler Ave over I-80	4'-10"	3'-10"	4'-4"

Structure Number	Sign Skew Angle (L) or (R)	Bridge Station	Bridge Structure Number	Contract Route Designation	a	b	cs	cw	ds	dw	e	f	g	No. of Brackets (Total)	p	q	Total Grating/Hndrl. Lengths (cw + dw)
1B016180R131.6A	0°	641+40	099-8324	I-80	-	-	-	-	16'-0"	-	-	54'-2 3/4"	4'-9"	4	-	-	-
1B016180R131.6B	0°	641+40	099-8324	I-80	-	-	-	-	14'-6"	-	-	72'-11 3/4"	*	4	-	-	-
1B016180L131.6C	0°	641+94	099-8324	I-80	61'-5 3/4"	-	14'-6"	-	-	-	-	-	*	4	-	-	-

**GENERAL NOTES**

- SPECIFICATIONS:**
- DESIGN: AASHTO Standard Specifications for Structural Supports for Highway Signs, Luminaires and Traffic Signals. ("AASHTO Specifications")
- CONSTRUCTION: Current (at time of letting) Illinois Department of Transportation Standard Specifications for Road and Bridge Construction, Supplemental Specifications and Special Provisions. ("Standard Specifications")
- LOADING: 90 M.P.H. WIND VELOCITY
- WALKWAY LOADING: Dead load plus 500 lbs. concentrated live load.
- MINIMUM CLEARANCE: 3" greater than bridge members at all locations. (All Obstructions)
- WELDING: All welds to be continuous unless otherwise shown. All welding to be done in accordance with current AWS D1.1 Structural Welding Code (Steel) and the Standard Specifications.
- MATERIALS: All Structural Steel Pipe shall be ASTM A53 Grade B with a minimum yield of 35,000 p.s.i., or A500 Grade B or C with a minimum yield of 46,000 p.s.i. If A500 pipe is substituted for A53, then the outside diameter shall be as detailed and wall thickness greater than or equal to A53. All Structural Steel Plates and Shapes shall conform to AASHTO M270 Gr. 36, Gr. 50 (M183, M223 Gr. 50).
- HIGH STRENGTH BOLTS: All bolts, washers, nuts and locknuts shall satisfy the requirements of ASTM designation A307 unless noted as "H.S." which shall require AASHTO M164 (A325), ASTM A449, or approved alternate. All fasteners shall be hot dip galvanized per AASHTO M232 unless otherwise specified.
- GALVANIZING: All Steel Grating, Plates, Shapes and Pipe shall be Hot Dip Galvanized after fabrication in accordance with AASHTO M111. Painting is not permitted.
- ANCHOR RODS: All-threaded rod shall conform to ASTM F1554 Grade 105, 3/4"  $\varnothing$  x 12" long, each with one plate washer and locknut and be hot dip galvanized per AASHTO M232. They shall be either cast into the concrete or epoxy grouted in accordance with Section 584 of the Standard Specifications. Minimum embedment in concrete shall be 9".

- Bracket spacing  $g \leq 6'-0"$ , max. Spacing shall be uniform if possible but may vary  $\pm 6"$  to miss existing obstruction (rail post, light poles, web stiffeners, splice plates, etc.). Adjust bracket lengths accordingly on skewed structures.
- Any design modifications shall be based on the current version of applicable specifications and submitted for the Engineer's approval.
- Unit price includes grating, handrail, brackets, supports, anchor bolts, fasteners, fabrication, delivery, erection, field drilling and other necessary items. Limits of payment are based on grating length (cw, dw) unless otherwise specified. For Safety Chain Details and Details D, F and G, see Base Sheet BM-4.
- If walkway bracket at safety chain location is behind sign, add angle to bracket. See detail on Base Sheet BM-4.

Dimensions a, b, e, f & g may vary as approved by the Engineer, see ①.  
When cw < cs and/or dw < ds, use alternate brackets without walkway supports where applicable, see ③.  
\*Varies, see separate table. Note Signs A, B, C and g1-g3 are listed South to North

**TOTAL BILL OF MATERIAL**

③ OVERHEAD SIGN STRUCTURE-BRIDGE MOUNTED	Foot	45
--	------	----

Signed Moussa A. Issa  
Dr. Moussa A. Issa, S.E. II. Lic. No. 081-005738  
Expires 11-30-2022  
Date 8/10/2022 For Sheets 47 thru 50



USER NAME = lisa.buntin	DESIGNED - AMS	REVISED -
PLOT SCALE = 0.166666' / in.	DRAWN - AMS	REVISED -
PLOT DATE = 8/9/2022	CHECKED - LAB, MI	REVISED -
	DATE - 8/12/2022	REVISED -

**STATE OF ILLINOIS**  
**DEPARTMENT OF TRANSPORTATION**

**BRIDGE MOUNT SIGN STRUCTURES**  
**GENERAL PLAN AND ELEVATION**

SCALE: SHEET 1 OF 4 SHEETS STA. TO STA.

F.A.U. RTE.	SECTION	COUNTY	TOTAL SHEETS	SHEET NO.
340	FAI 80 21 STRUCTURE 9	WILL	130	47
CONTRACT NO. 62R30				
ILLINOIS FED. AID PROJECT				

MODEL: BL\_PR\_00 - Plan 2 (SHEET) FILE NAME: C:\Users\mostafan\Documents\Projects\2018\CH4401\4401\_180022\02-74\3\5\scms\CAD\62R30\Sheet2-3-Structural\Sign\_Structures\0162R30-SHT-SIGN-STRUCT-DET-22

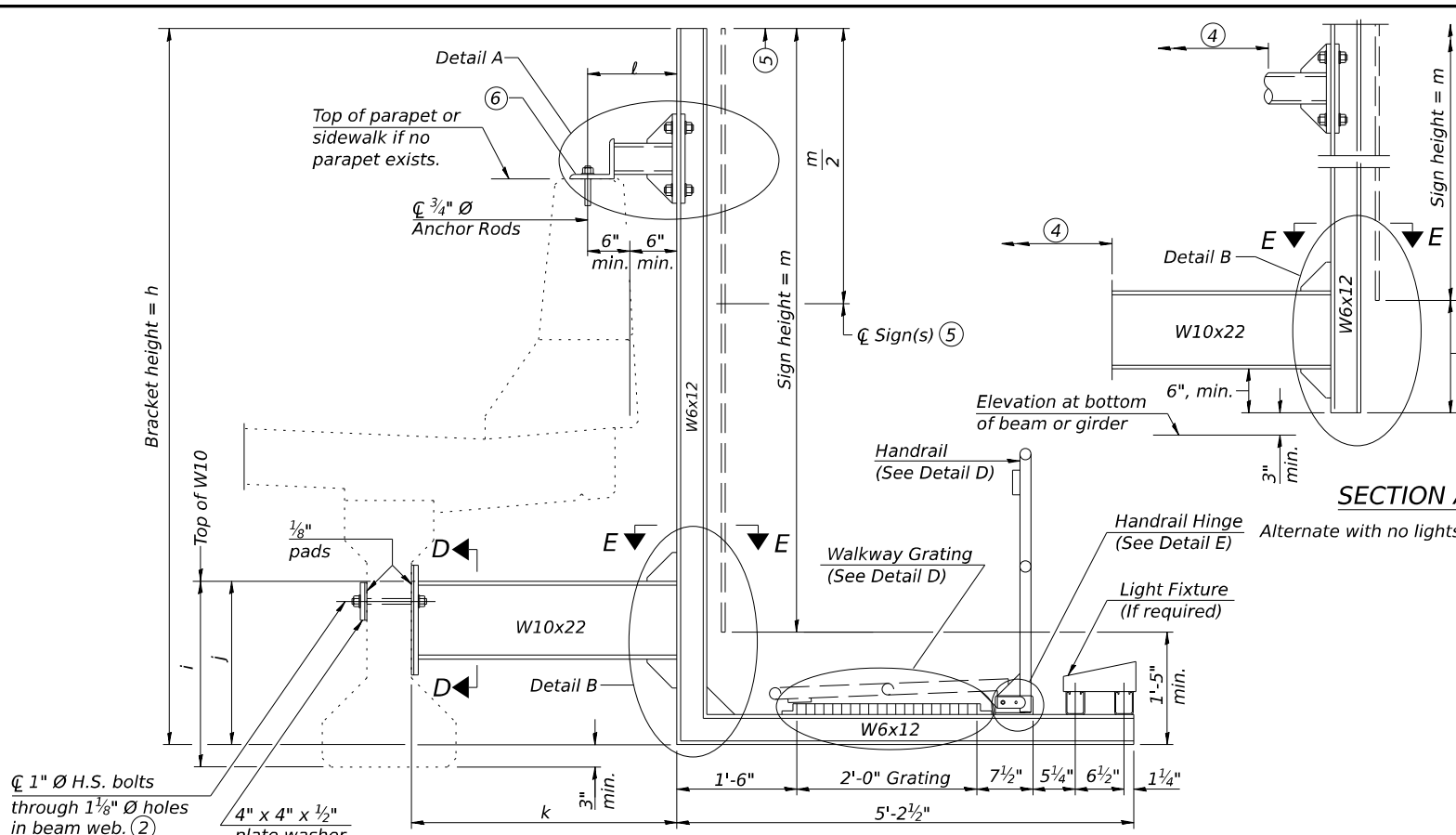

**SECTION A-A** Details for mounting to PPC I Beam or Bulb "T" & Details for mounting to parapet w/o rail

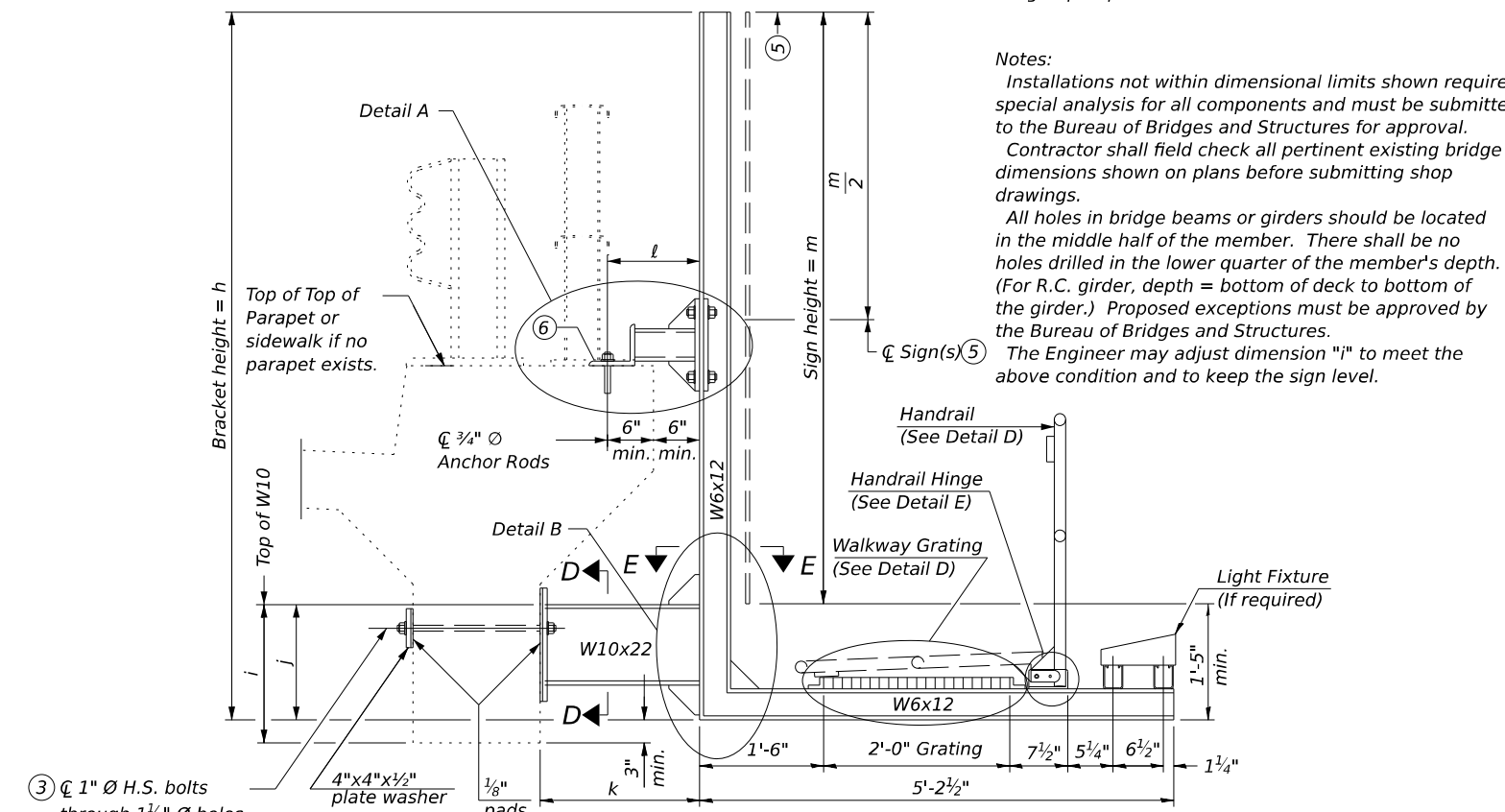

**SECTION A-A** Details for mounting to integral reinforced concrete girder & Details for mounting on safety curb with surface-mount bridge rail

**Notes:**  
 Installations not within dimensional limits shown require special analysis for all components and must be submitted to the Bureau of Bridges and Structures for approval. Contractor shall field check all pertinent existing bridge dimensions shown on plans before submitting shop drawings.  
 All holes in bridge beams or girders should be located in the middle half of the member. There shall be no holes drilled in the lower quarter of the member's depth. (For R.C. girder, depth = bottom of deck to bottom of the girder.) Proposed exceptions must be approved by the Bureau of Bridges and Structures.  
 The Engineer may adjust dimension "i" to meet the above condition and to keep the sign level.

- ① Holes in new steel members may be drilled in the fabrication shop or in the field. Field drill existing members.
- ② For new PPC I beams, holes shall be formed during casting. For existing PPC I beams, prestressing strand locations shall be determined and spaced to miss strands by 6", min. Minimize spalling during field drilling of existing beams.
- ③ For new construction, form holes. For existing RC beams, locate primary reinforcement and space holes to miss by 6", min. Minimize spalling and concrete fracturing/damage during field drilling of existing concrete. Spalls over ¼" deep or beyond the coverage of the 4x4 plate washer shall be repaired with epoxy mortar before installing washer.
- ④ For attachment details of 3½" pipe and W10x22, see other sections as applicable.
- ⑤ Sign shall not extend more than 6" above top of bracket, and this dimension may vary to keep sign level if bridge is on grade or vertical curve. Multiple signs of various heights shall share a common horizontal centerline and use equal bracket heights. If no sign is attached to a W6x12 vertical (bracket only supporting walkway), dimension h shall be the same as an adjacent bracket with a sign attached, unless Engineer specifically directs shorter brackets due to locational restraints on future uses. (See Detail A for minimum bracket height.)
- ⑥ For bridge mounted sign structures installed on new bridges with railing, during design, bracket spacing must be coordinated with railing post spacing and the Contractor must install upper brackets prior to railing installation. For bridge mounted sign structures installed on existing bridges with railing, during design, brackets spacing must be coordinated with railing post spacing and the Contractor must temporarily remove sections of railing to facilitate upper bracket installation. If it is determined during design that existing railings can't be removed, alternate upper connection details must be developed for the contract plans and approved by the Bureau of Bridges and Structures.

**NOTE:**  
 1. Walkway grating, walkway brackets, handrail, lighting and associated components will not be installed in Contract 62R30.

For Details A & B, Sections C-C, D-D and E-E, see Base Sheet BM-3.  
 For Details D & E, see Base Sheet BM-4.

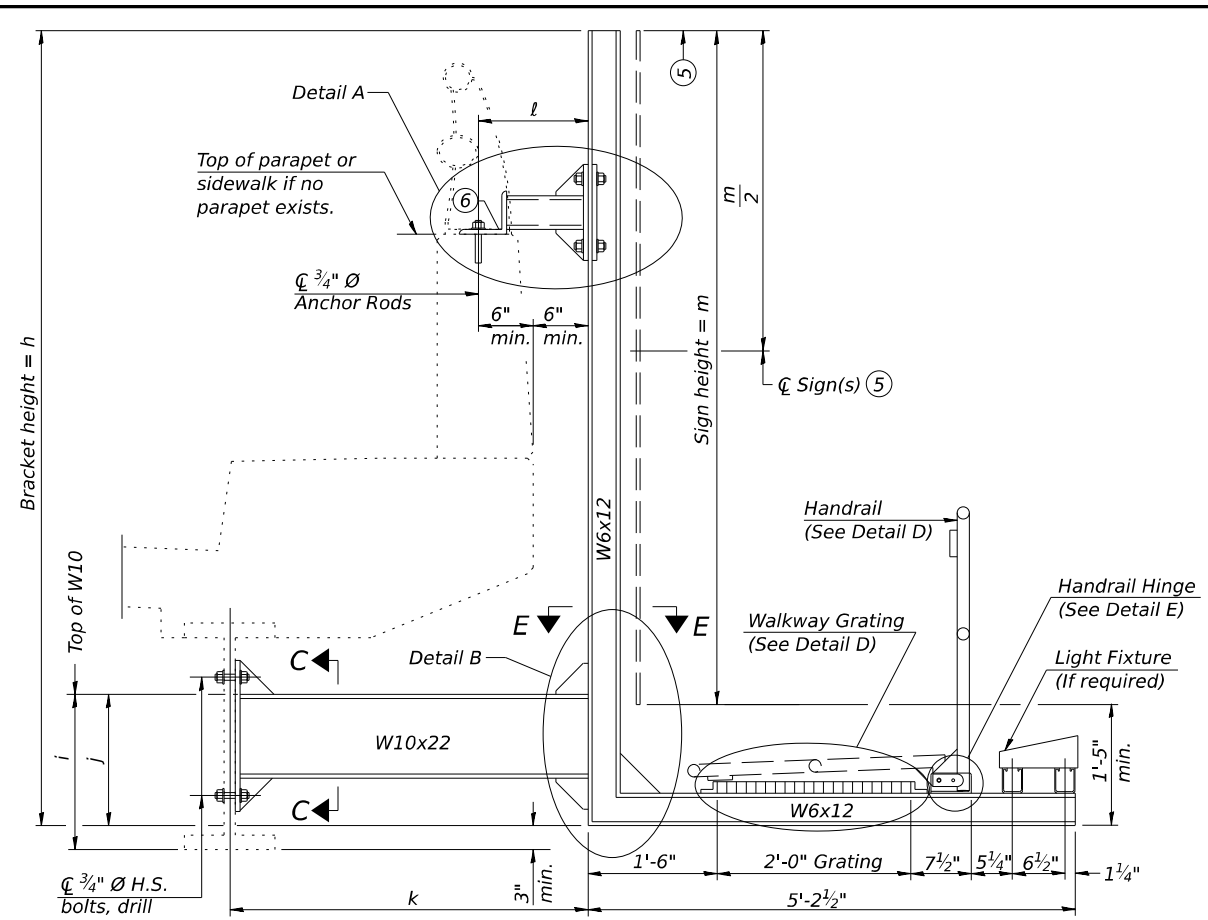

**SECTION A-A** Details for mounting to steel beam or girder & Details for mounting with existing parapet mounted rail

Structure Number	Station	h	i	j	k max. (10'-0" max.)	l max. (8'-0" max.)	m (15'-0" max.)
1B016I80R131.6A	641+40	11'-5"	2'-5"	1'-9"	3'-9"	1'-1"	9'-0"
1B016I80R131.6B	641+40	13'-0"	2'-5"	1'-9"	3'-9"	1'-1"	13'-0"
1B016I80L131.6C	641+94	13'-0"	2'-5"	1'-9"	3'-9"	1'-1"	13'-0"



USER NAME = mostafan	DESIGNED - AMS	REVISED -
PLOT SCALE = 0.166666' / in.	DRAWN - AMS	REVISED -
PLOT DATE = 8/10/2022	CHECKED - LAB, MI	REVISED -
	DATE - 8/12/2022	REVISED -

**STATE OF ILLINOIS**  
**DEPARTMENT OF TRANSPORTATION**

**BRIDGE MOUNT SIGN STRUCTURES**  
**WALKWAY AND CONNECTION DETAILS**

SCALE: SHEET 2 OF 4 SHEETS STA. TO STA.

F.A.U. R.T.E.	SECTION	COUNTY	TOTAL SHEETS	SHEET NO.
340	FAI 80 21 STRUCTURE 9	WILL	130	48
ILLINOIS			CONTRACT NO. 62R30	



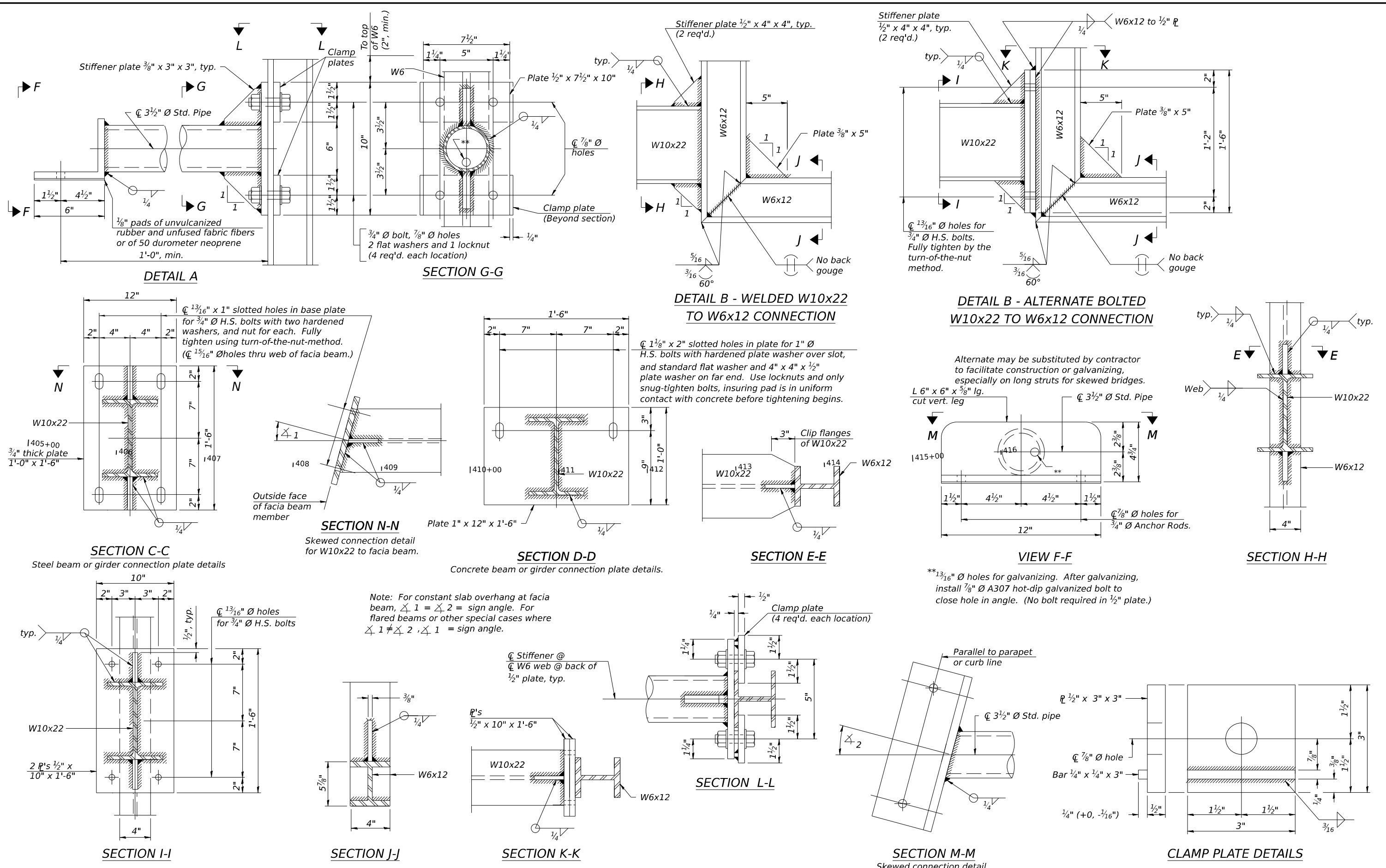

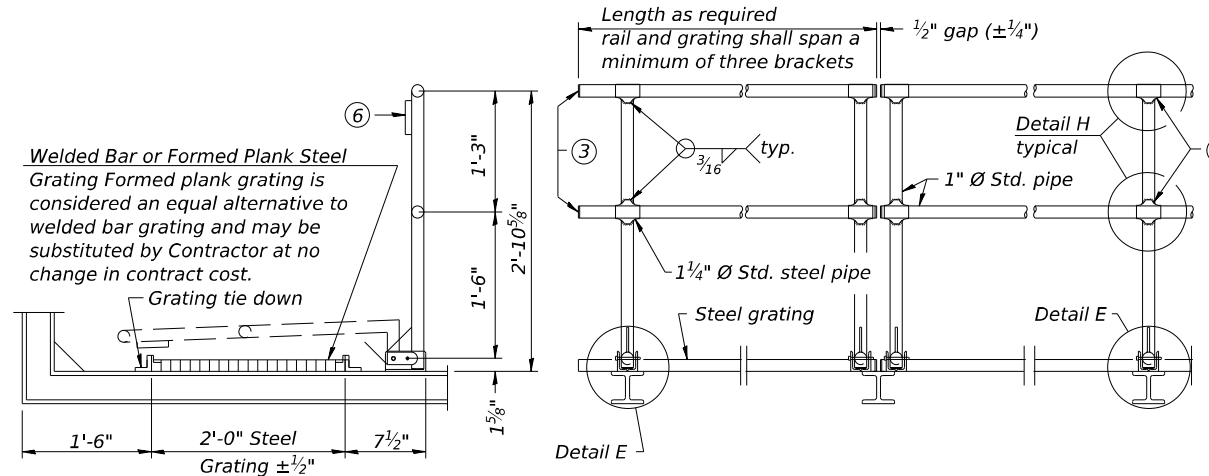

**SIDE ELEVATION**     **DETAIL D HANDRAIL**     **FRONT ELEVATION**

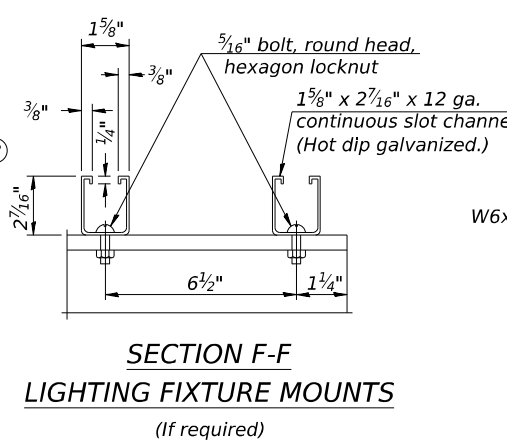

**SECTION F-F**  
**LIGHTING FIXTURE MOUNTS**  
(If required)

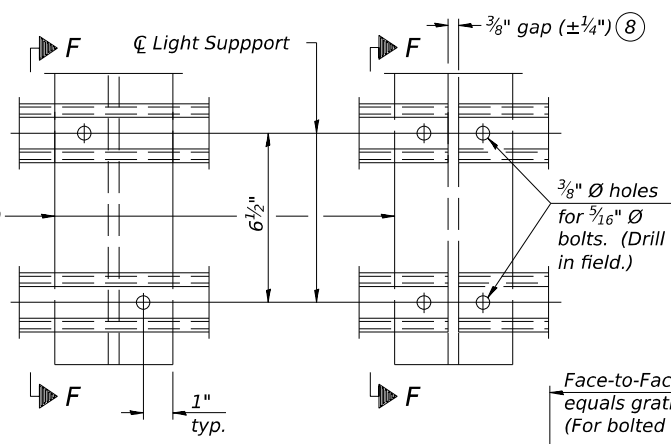

**DETAIL F**     **DETAIL G**

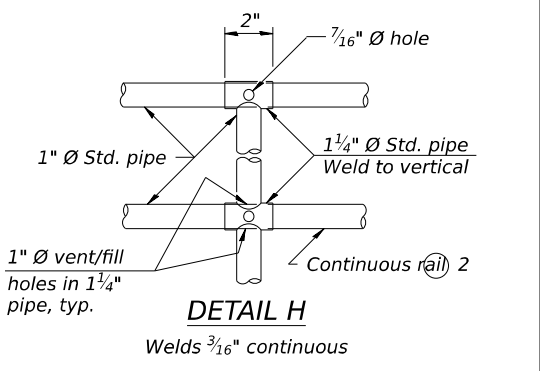

**DETAIL H**  
Welds 3/16" continuous

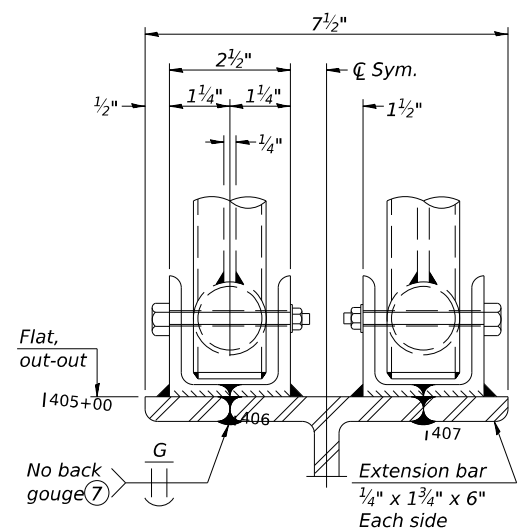

**ELEVATION AT HANDRAIL JOINT**  
(Details not shown same as "FRONT ELEVATION")

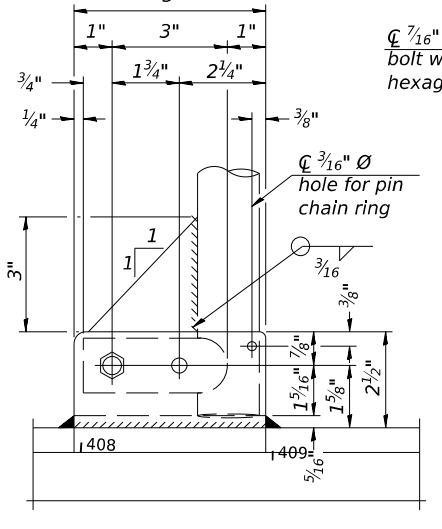

**SIDE ELEVATION**

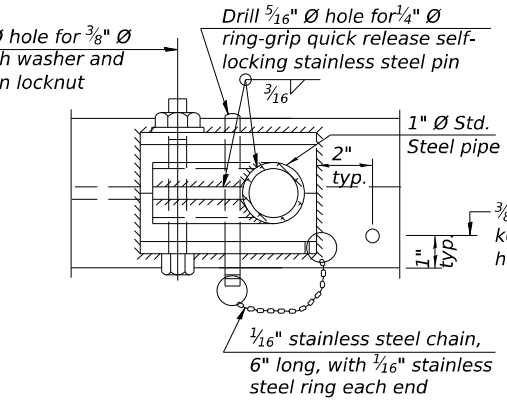

**PLAN AT SINGLE HANDRAIL HINGE**

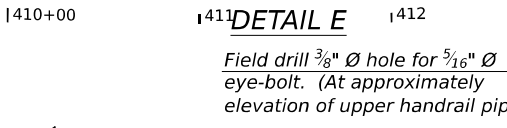

**DETAIL E**

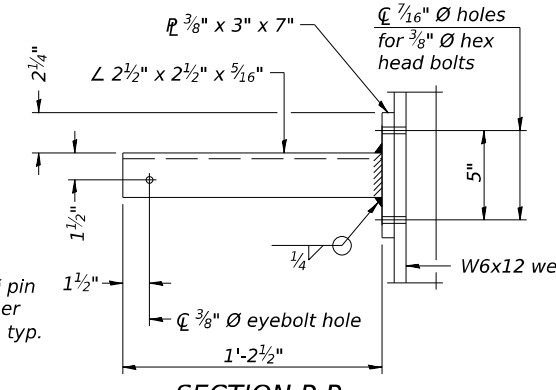

**SECTION P-P**

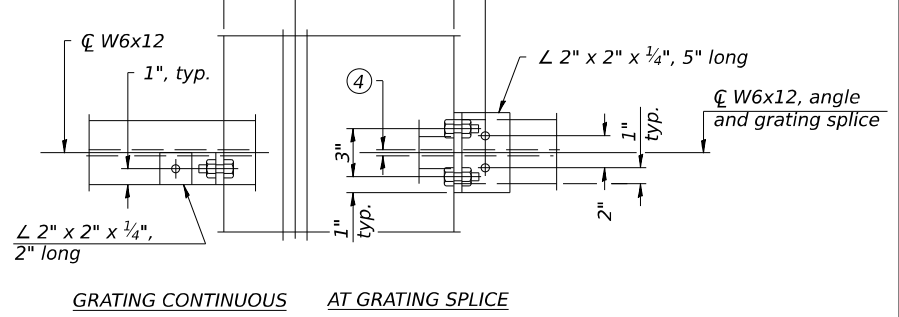

**VIEW W-W**

**GRATING CONTINUOUS**     **AT GRATING SPLICE**

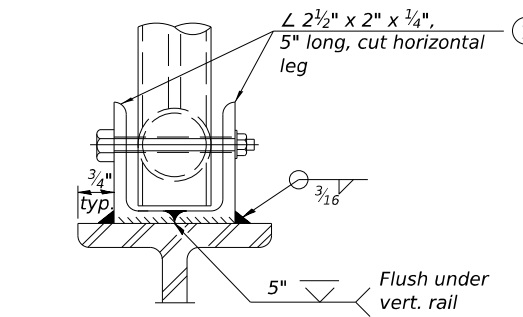

**FRONT ELEVATION**

(See above Elevations for dimensions.)

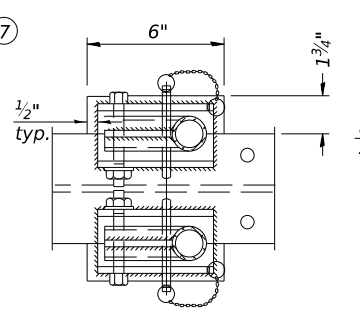

**PLAN AT HANDRAIL JOINT**

(For Details, see Elevations.)

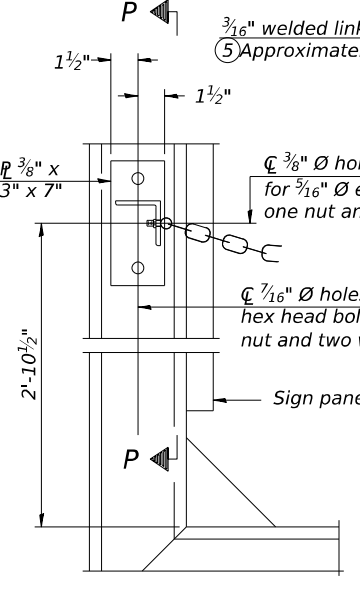

**SAFETY CHAIN ATTACHMENT**

(With Sign Present)  
Items not shown same as "SIDE ELEVATION" and "SAFETY CHAIN"

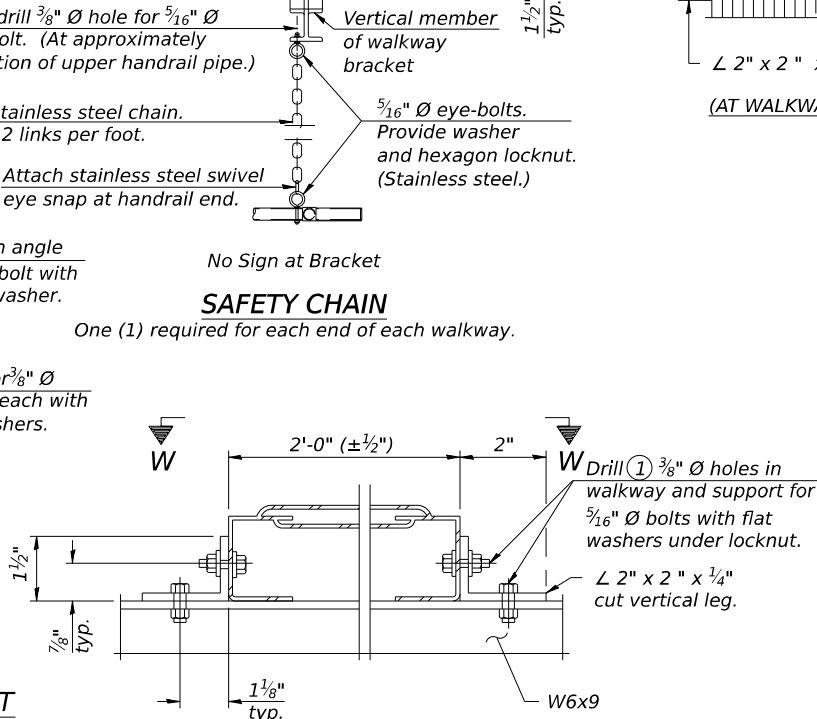

**ALTERNATE FORMED PLANK GRATING DETAILS**  
Plank Grating: nominal depth = 2 1/2" (± 1/2"); perforated or expanded steel sheet with a non-skid surface (non-serrated) concentrated load capacity = 500 lbs. with 6'-0" clear span.

**NOTES**

- ① Drilling holes in grating may be done in shop or field, based on Contractor's preference and subject to accurate alignment. Field drilled holes must be touched up with galvanized paint.
- ② Horizontal rail member shall be continuous thru 1 1/4" Ø pipe. Provide 7/16" Ø hole in 1 1/4" Ø pipe for 3/8" Ø bolt. Field drill 7/16" Ø hole in horizontal rail member. Provide washer and locknut for bolt. (Use 5/16" eyebolts in 7/16" Ø holes on top rail at ends only.)
- ③ Install standard force-fit end caps or weld 1/8" end plates with 3/8" c.f.w. and grind smooth. (All rail ends.)
- ④ 3/8" (± 1/4") gap between grating panels at splice.
- ⑤ Chain to be type 304L stainless steel suitable for prolonged exterior exposure. Approximately 3'-6" long chain per location. Maximum sag with handrail erected = 4".
- ⑥ 1 1/8" x 1/2" x 2" welded to handrail posts to protect locations that contact grating.
- ⑦ Extrusions may be used in lieu of details shown, with approval by Engineer.
- ⑧ Field cut ends of light support channels shall be free of burrs or hazardous projections and coated with zinc-rich primer or equivalent.

**BM-4**     **2-17-2017**

USER NAME = mosafan	DESIGNED - AMS	REVISED -
PLOT SCALE = 0.166666' / in.	DRAWN - AMS	REVISED -
PLOT DATE = 8/10/2022	CHECKED - LAB, MI	REVISED -
	DATE - 8/12/2022	REVISED -

**STATE OF ILLINOIS**  
**DEPARTMENT OF TRANSPORTATION**

**BRIDGE MOUNT SIGN STRUCTURES**  
**WALKWAY DETAILS**

SCALE: SHEET 4 OF 4 SHEETS STA. TO STA.

F.A.U. RTE.	SECTION	COUNTY	TOTAL SHEETS	SHEET NO.
340	FAI 80 21 STRUCTURE 9	WILL	130	50
CONTRACT NO. 62R30			ILLINOIS FED. AID PROJECT	

## ELECTRICAL SYMBOLS FOR PROPOSED WORK

## GENERAL ELECTRICAL CALLOUTS

**LIGHTING UNIT: TYPE AS INDICATED**

	47'-6" M.H., 15 FT. DAVIT ARM LED TYPE G LUMINAIRE GROUND MOUNTED
	47'-6" M.H., 6 FT. DAVIT ARM LED TYPE G LUMINAIRE MOUNTED ON PARAPET WALL
	47'-6" M.H., 2-6 FT. DAVIT ARM 2-LED TYPE G LUMINAIRE MOUNTED ON MEDIAN WALL
	TEMPORARY LIGHTING UNIT, HEIGHT AS INDICATED ON PLANS
	UNDERPASS LUMINAIRE: LED, TYPE AS SHOWN ON PLANS
	<b>ELECTRIC HANDHOLE: TYPE AS INDICATED</b>
	TYPE E1: PRECAST CONCRETE, 21.5"x21.5"x30", IDOT STANDARD 814001
	TYPE E2: PRECAST CONCRETE-HEAVY DUTY, 22"x22"x30", IDOT STANDARD 814001
	TYPE C1: COMMUNICATIONS VAULT, 48"x48"x36"
	TYPE S1: PRECAST CONCRETE-HEAVY DUTY, 22"x22"x36"
	TYPE S2: PRECAST CONCRETE-HEAVY DUTY SPECIAL, 30"x30"x36"
	<b>DOUBLE HANDHOLE</b>
	<b>ELECTRIC MANHOLE</b>
	<b>JUNCTION BOX: TYPE AND SIZE AS INDICATED ON PLANS</b>
	<b>PULL BOX: TYPE AND SIZE AS INDICATED ON PLANS</b>
	<b>TELEPHONE CONNECTION</b>
	<b>FIBER OPTIC COMMUNICATIONS HUT</b>

	SIGN STRUCTURE-CANTILEVER TYPE
	SIGN STRUCTURE-TRUSS TYPE
	SIGN STRUCTURE-BRIDGE MOUNT TYPE
	DYNAMIC MESSAGE SIGN
	FLASHING BEACON SIGN
	CLOSED CIRCUIT TELEVISION CAMERA
	CONTROLLER CABINET: LIGHTING DUPLEX TYPE WITH SCADA (DOOR SIDE AS INDICATED)
	CONTROLLER: LIGHTING, SINGLE
	TEMPORARY WOOD POLE, LENGTH AS INDICATED ON THE PLANS
	ELECTRIC UTILITY POLE
	POLE MOUNTED ELECTRIC UTILITY TRANSFORMER(S)
	PAD MOUNTED ELECTRIC UTILITY TRANSFORMER
	GROUND ROD
	DISCONNECT SWITCH (RATING AS INDICATED)
	PHOTOCELL

	AERIAL CABLE
	FLEXIBLE CONDUIT
	RACEWAY EMBEDDED IN STRUCTURE
	UNDERGROUND CONDUIT: TYPE AND SIZE AS INDICATED ON PLANS
	EXPOSED CONDUIT
	RACEWAY OR DIRECT BURIAL CABLE UNDERGROUND WITHOUT ENCASEMENT
	RIGID GALVANIZED STEEL CONDUIT SLEEVE, INSTALLED BELOW PAVEMENT
	UNDERGROUND REINFORCED CONCRETE ENCASED CONDUIT DUCTBANK, UNLESS NOTED OTHERWISE. (NUMBER, TYPE, AND SIZE OF DUCTS AS SHOWN)
	CONDUIT TURNED DOWN
	CONDUIT TURNED UP

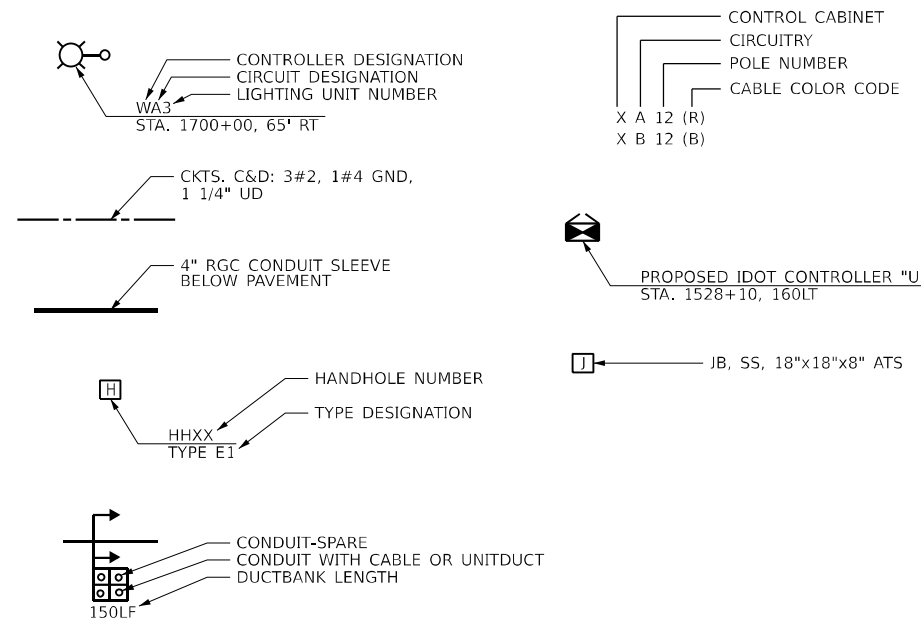

## ELECTRICAL SYMBOLS FOR EXISTING CONDITIONS

	EXISTING LIGHT TOWER TO REMAIN
	EXISTING IDOT LIGHTING UNIT, TWIN LUMINAIRE TO REMAIN
	EXISTING IDOT LIGHTING UNIT TO REMAIN
	EXISTING UNDERPASS LUMINAIRE TO REMAIN
	EXISTING ELECTRIC MANHOLE
	EXISTING ELECTRIC HANDHOLE
	EXISTING DOUBLE HANDHOLE
	EXISTING JUNCTION BOX
	EXISTING TELEPHONE CONNECTION
	EXISTING FIBER OPTIC COMMUNICATIONS HUT

	EXISTING WIRELESS VEHICLE DETECTION SYSTEM RADIO
	EXISTING CDOT ELECTRIC HANDHOLE/MANHOLE
	EXISTING LIGHTED SIGN STRUCTURE- CANTILEVER TYPE
	EXISTING LIGHTED SIGN STRUCTURE-TRUSS TYPE
	EXISTING LIGHTED SIGN STRUCTURE- BRIDGE MOUNT TYPE
	EXISTING DYNAMIC MESSAGE SIGN
	EXISTING FLASHING BEACON SIGN
	EXISTING CLOSED CIRCUIT TELEVISION CAMERA
	EXISTING LIGHTING CONTROLLER, DUPLEX
	EXISTING SURVEILLANCE POLE
	EXISTING ELECTRIC UTILITY POLE
	EXISTING WOOD POLE
	EXISTING UTILITY SERVICE CONNECTION, POLE MOUNTED
	EXISTING UTILITY SERVICE CONNECTION, PAD MOUNTED

	EXISTING CONCEALED CONDUIT IN STRUCTURE
	EXISTING EXPOSED CONDUIT
	EXISTING RACEWAY OR DIRECT BURIED CABLE WITHOUT ENCASEMENT
	EXISTING CONCEALED CONDUIT UNDERGROUND, TRENCHED OR PUSHED
	EXISTING ELECTRIC CABLE IN CONDUIT SLEEVE
	EXISTING AERIAL CABLE TO REMAIN
	EXISTING ELECTRICAL EQUIPMENT TO BE ABANDONED

## TYPICAL EXISTING TO BE REMOVED SYMBOLS

	EXISTING IDOT LIGHT POLE AND MAST ARM TO BE REMOVED
	EXISTING UNDERPASS LUMINAIRE TO BE REMOVED
	EXISTING JUNCTION BOX TO BE REMOVED
	EXISTING SIGN STRUCTURE-CANTILEVER TYPE TO BE REMOVED
	DYNAMIC MESSAGE SIGN TO BE REMOVED
	FLASHING BEACON SIGN TO BE REMOVED
	EXISTING LIGHTING CONTROLLER, DUPLEX, TO BE REMOVED
	EXISTING POLE MOUNTED UTILITY SERVICE CONNECTION TO BE REMOVED
	EXISTING LIGHT TOWER TO BE REMOVED
	EXISTING WOOD POLE TO BE REMOVED

MODEL: Default  
 FILE: \\msf\proj\17\170027\02-TRANS\SYSTEMS\SCORP-PW1-HOSTED\Documents\Drawings\2018\CH401\401\_10027\02-TRANS\SYSTEMS\CDAD\2018\Sheet21-Lighting\02R30-SHT-UT-01.dwg  
 303 EAST WACKER DRIVE, SUITE 1400  
 CHICAGO, IL 60601-2776  
 PHONE: (312) 373-7700 FAX: (312) 373-6800



USER NAME = mostafan	DESIGNED - MAE	REVISED -
PLOT SCALE = 2,000' / in.	DRAWN - CAM	REVISED -
PLOT DATE = 8/10/2022	CHECKED - TJL	REVISED -
	DATE - 7/22/2022	REVISED -

**STATE OF ILLINOIS  
DEPARTMENT OF TRANSPORTATION**

**WHEELER AVENUE OVER F.A.I. ROUTE 80  
LIGHTING SYMBOLS**

SCALE: N.T.S. SHEET 1 OF 7 SHEETS STA. TO STA.

F.A.U. RTE.	SECTION	COUNTY	TOTAL SHEETS	SHEET NO.
340	FBI 80 21 STRUCTURE 9	WILL	130	51
CONTRACT NO. 62R30				
ILLINOIS FED. AID PROJECT				

I-80 AT WHEELER AVE - 62R30			
IDOT ELECTRICAL PAY ITEMS & QUANTITIES			
Item #	Description	Units	Quantity
81603100	UNIT DUCT, 600V, 4-1/C NO.6, 1/C NO.6 GROUND, (XLP-TYPE USE), 1 1/4" DIA. POLYETHYLENE	FOOT	420
81800400	AERIAL CABLE, 4-1/C NO. 2 WITH MESSENGER WIRE	FOOT	382
Z0033028	MAINTENANCE OF LIGHTING SYSTEM	CAL MO	12
X0325815	REMOVE EXISTING CABLE	FOOT	953

ABBREVIATIONS	
SYMBOL	DESCRIPTION
AC	ALTERNATING CURRENT
A/C	AERIAL CABLE
AFG	ABOVE FINISHED GRADE
CB	CIRCUIT BREAKER
CKT	CIRCUIT
CM	CENTIMETER
CNC	COILABLE NONMETALLIC CONDUIT
CT	CURRENT TRANSFORMER
CP	CONTROL PANEL
DA	DAVIT ARM
DC	DIRECT CURRENT
DIA	DIAMETER
DP	DISTRIBUTION PANEL
E	EXISTING UNIT TO REMAIN
ECA	ELECTRIC CABLE ASSEMBLY
EM	EXISTING UNIT TO BE MODIFIED (e.g. NEW LUMINAIRE, BALLAST OR MAST ARM)
ER	EXISTING RELOCATED UNIT
ET	EXISTING TEMPORARY UNIT TO REMAIN
ETR	EXISTING TEMPORARY RELOCATED UNIT
FT	FEET OR FOOT
FND BW	FOUNDATION BARRIER WALL
FND BW OS	FOUNDATION BARRIER WALL OFFSET
FND CON	FOUNDATION CONCRETE
FND CON OS	FOUNDATION CONCRETE OFFSET
FND MET	FOUNDATION METAL
FND PW	FOUNDATION PARAPET WALL
FU	FUSE
GFCI	GROUND FAULT CIRCUIT INTERRUPTER
GND	GROUND
HID	HIGH INTENSITY DISCHARGE
JB	JUNCTION BOX
KVA	KILOVOLT-AMPERE
KW	KILOWATTS
M	METER
MA	MAST ARM
MM	MILLIMETER
MH	MOUNTING HEIGHT
NO. #	NUMBER
P	PROPOSED
PB	PUSH BUTTON
PNL	PANEL
PVCC RGC	PVC COATED RIGID GALVANIZED CONDUIT
PT	POTENTIAL TRANSFORMER
R	EXISTING UNIT TO BE REMOVED (OWNER SALVAGED U.N.O.)
RL	RELOCATED
RR	EXISTING UNIT TO BE REMOVED AND RELOCATED (REINSTALLED)
RECP	RECEPTACLE
RGC	RIGID GALVANIZED CONDUIT
RGS	RIGID GALVANIZED STEEL
SEL SW	SELECTOR SWITCH
SPARE	SPARE
SPACE	SPACE
SS	STAINLESS STEEL
STA	STATION
T	TEMPORARY LIGHTING UNIT
TB	TRANSFORMER BASE
TMP	TEMPORARY
TR	TEMPORARY UNIT TO BE REMOVED, SALVAGE EQUIPMENT AS SPECIFIED
TRR	TEMPORARY UNIT TO BE REMOVED AND RELOCATED
TUR	TEMPORARY UNIT ON UTILITY POLE TO BE REMOVED
UC	UNDERGROUND CONDUIT
UD	UNIT DUCT
U.N.O.	UNLESS NOTED OTHERWISE
WP	WOOD POLE
XFMR	TRANSFORMER

**GENERAL NOTES:**

1. THE SCALE SHOWN ON PLAN DRAWINGS APPLIES ONLY TO THE FULL SIZE PLANS AND NOT TO REDUCED SIZE PLANS.
2. ALL LUMINAIRES SHALL BE ORIENTED WITH THE OPTICS PERPENDICULAR TO THE ROADWAY UNLESS OTHERWISE INDICATED OR DIRECTED BY THE ENGINEER.
3. CONDUITS AND UNIT DUCTS SHALL BE INSTALLED AT A MINIMUM 30" DEPTH BELOW GRADE AND POSITIONED IN THE FIELD TO AVOID CONFLICT WITH ROADWAY UNDERDRAINS AND OTHER EXISTING AND PROPOSED UTILITIES.
4. WHERE THE CONTRACTOR'S EXCAVATION MEETS AN OBSTRUCTION, THE CONTRACTOR SHALL NOTIFY THE ENGINEER FOR DIRECTION IN WRITING PRIOR TO EXCAVATION.
5. ALL REMOVED EQUIPMENT AND MATERIALS THAT WILL NOT BE REUSED SHALL BE RETURNED TO THE AGENCY THAT OWNS THE EQUIPMENT. THE CONTRACTOR SHALL MAKE ALL NECESSARY ARRANGEMENTS TO SAFELY TRANSPORT AND DELIVER REMOVED EQUIPMENT TO THE AGENCY'S PUBLIC WORKS STORAGE FACILITY/YARD DESIGNATED BY EACH AGENCY. COST OF THIS WORK, INCLUDING PROPERLY PACKAGING AND HANDLING OF EQUIPMENT, SHALL BE INCLUDED IN THE UNIT BID PRICE FOR THE ITEMS BEING REMOVED.
6. LIGHTING AND ELECTRICAL SYMBOLS ARE OVERSIZED ON THE PLANS FOR CLARITY. CONTRACTOR SHALL USE STATIONS AND SETBACKS TO ACCURATELY LOCATE EQUIPMENT.

MODEL: Default  
FILE: M:\e\p\work\mstafan\systems\complib\complib\systems\corporate\pnl\hds\ed\Documents\Drawings\2018\CH4001\4001100027\02-TransSystems\CD\62R30\Sheet62-1-Lighting\62R30-SHT-62.dgn



USER NAME = mostafan	DESIGNED - MAE	REVISED -
	DRAWN - CAM	REVISED -
PLOT SCALE = 2,000 " / in.	CHECKED - TJL	REVISED -
PLOT DATE = 8/10/2022	DATE - 8/12/2022	REVISED -

**STATE OF ILLINOIS  
DEPARTMENT OF TRANSPORTATION**

**WHEELER AVENUE OVER F.A.I. ROUTE 80  
LIGHTING NOTES, ABBREVIATIONS AND QUANTITIES**

SCALE: N.T.S. SHEET 2 OF 7 SHEETS STA. TO STA.

F.A.U. RTE.	SECTION	COUNTY	TOTAL SHEETS	SHEET NO.
340	F&I 80 21 STRUCTURE 9	WILL	130	52
CONTRACT NO. 62R30				
ILLINOIS FED. AID PROJECT				

### NOTES

1. PROVIDE A TEMPORARY AERIAL CABLE FEED WITH MESSENGER WIRE BETWEEN EXISTING LIGHTING UNITS AS SHOWN. ROUTE AERIAL CABLE ON WOOD POLES IN ORDER TO RECONNECT THE ROADWAY LIGHTING CIRCUITS ACROSS THE WHEELER AVE BRIDGE.
2. THE CONTRACTOR SHALL MAINTAIN THE EXISTING LIGHTING EQUIPMENT FULLY OPERATIONAL ON THE TRAFFIC SIDE OF THE ROADWAY. THE CONTRACTOR SHALL REWIRE EXISTING LIGHTING CIRCUITS AS NECESSARY TO KEEP ALL OF THE LIGHT POLES OPERATIONAL DURING CONSTRUCTION. THE CONTRACTOR SHALL PROVIDE ANY EQUIPMENT, MATERIALS, AND LABOR NECESSARY TO ACCOMPLISH THIS GOAL EVEN IF NOT SPECIFIED OR DETAILED IN THE PLANS. THIS WORK SHALL BE PAID FOR UNDER EACH INDIVIDUAL LIGHTING PAY ITEMS.
3. THE CONTRACTOR SHALL SPLICE AERIAL CABLE AT LIGHT POLES USING HEAT-SHRINK CAPS WITH FACTORY APPLIED WATERPROOF SEALANT.
4. WHERE THE CONTINUITY OF CIRCUITS OR CONDUITS SERVING ANY EXISTING LIGHTING/EQUIPMENT TO REMAIN IN OPERATION IS INTERFERED WITH, RE-ROUTE, AND REWIRE SUCH CIRCUITS OR CONDUITS IN ORDER TO KEEP THE LIGHTING SYSTEM OPERATIONAL AT ALL TIMES.
5. THE TEMPORARY WIRING OF THE EXISTING LIGHTING MUST BE INSTALLED AND THE LIGHTING SYSTEM MADE FULLY OPERATIONAL BEFORE THE EXISTING UNDERGROUND CONDUITS AND WIRING ARE DISCONNECTED OR REMOVED.

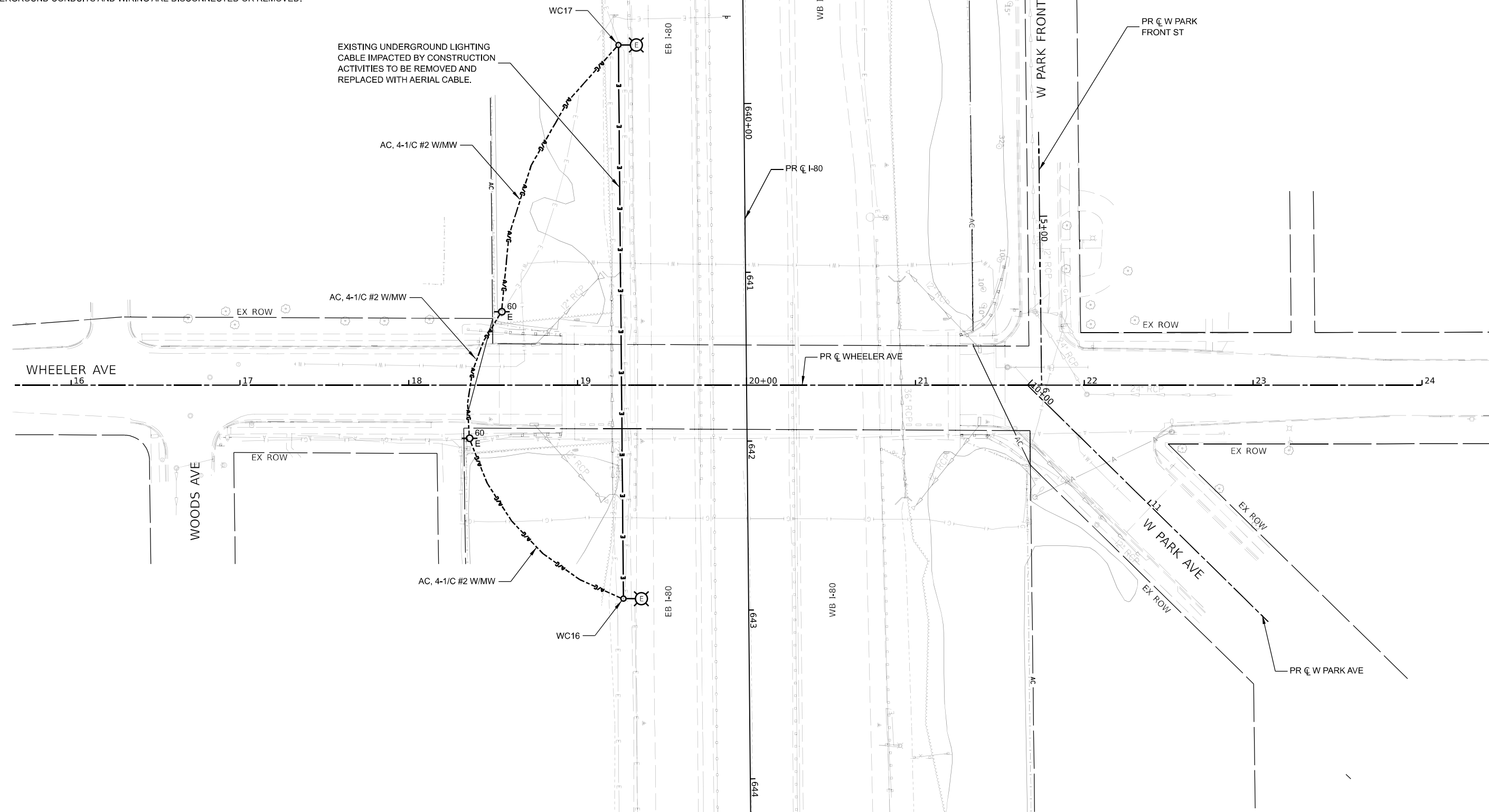
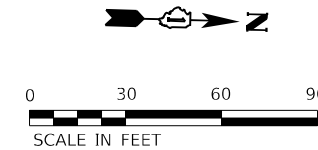

MODEL: Default  
 FILE: W:\User\mstafan\Documents\Projects\2018\CH44014401\10002702\TIA\GIS\System\CD\2018\3D\Sheet\21-Lighting\21-Lighting-D-62R30-SH-T-03.dgn  
 MODEL: Default  
 FILE: W:\User\mstafan\Documents\Projects\2018\CH44014401\10002702\TIA\GIS\System\CD\2018\3D\Sheet\21-Lighting\21-Lighting-D-62R30-SH-T-03.dgn



USER NAME = mostafan	DESIGNED - MAE	REVISED -	
	DRAWN - CAM	REVISED -	
PLOT SCALE = 60,000' / in.	CHECKED - TJL	REVISED -	
PLOT DATE = 8/11/2022	DATE - 8/12/2022	REVISED -	

**STATE OF ILLINOIS  
 DEPARTMENT OF TRANSPORTATION**

**WHEELER AVENUE OVER F.A.I. ROUTE 80  
 TEMPORARY LIGHTING PLAN - WHEELER AVENUE**

SCALE: 1"=30'      SHEET 3 OF 7 SHEETS      STA. 16+00      TO STA. 24+00

F.A.U. RTE.	SECTION	COUNTY	TOTAL SHEETS	SHEET NO.
340	FAI 80 21 STRUCTURE 9	WILL	130	53
CONTRACT NO. 62R30				
ILLINOIS   FED. AID PROJECT				

**LEGEND**



**WARNING SIGN LIGHTING NOTES:**

1. PROVIDE AN UNDERGROUND FEED BETWEEN EXISTING POWER SOURCE AND EXISTING LIGHTED WARNING SIGNS AS SHOWN. PROVIDE AND INSTALL UNIT DUCT UNDERGROUND TO WARNING SIGN EAST OF WHEELER AVE.
2. THE CONTRACTOR SHALL CONNECT WIRING TO EXISTING CIRCUITS AND POWER SOURCE TO MAINTAIN THE OPERATION OF THE LIGHTS ON THE SIGNS.
3. WHERE THE CONTINUITY OF CIRCUITS OR CONDUITS SERVING ANY EXISTING LIGHTING OR EQUIPMENT TO REMAIN IN OPERATION IS INTERFERED WITH, RE-ROUTE, AND REWIRE AFFECTED CIRCUITS OR CONDUITS IN ORDER TO KEEP THE LIGHTS OPERATIONAL AT ALL TIMES.
4. THE TEMPORARY WIRING OF THE EXISTING SIGN LIGHTING MUST BE INSTALLED AND THE WARNING LIGHTS MADE FULLY OPERATIONAL BEFORE THE EXISTING UNDERGROUND CONDUITS AND WIRING ARE DISCONNECTED OR REMOVED.
5. THE CONTRACTOR SHALL MAINTAIN THE EXISTING LIGHTING EQUIPMENT FULLY OPERATIONAL ON THE TRAFFIC SIDE OF THE ROADWAY. THE CONTRACTOR SHALL REWIRE EXISTING LIGHTING CIRCUITS AS NECESSARY TO KEEP ALL THE LIGHT POLES OPERATIONAL DURING CONSTRUCTION. THE CONTRACTOR SHALL PROVIDE ANY EQUIPMENT, MATERIALS, AND LABOR NECESSARY TO ACCOMPLISH THIS TASK EVEN IF NOT SPECIFIED OR DETAILED IN THE PLANS. THIS WORK SHALL BE PAID FOR UNDER EACH INDIVIDUAL LIGHTING PAY ITEMS.

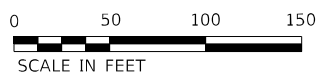
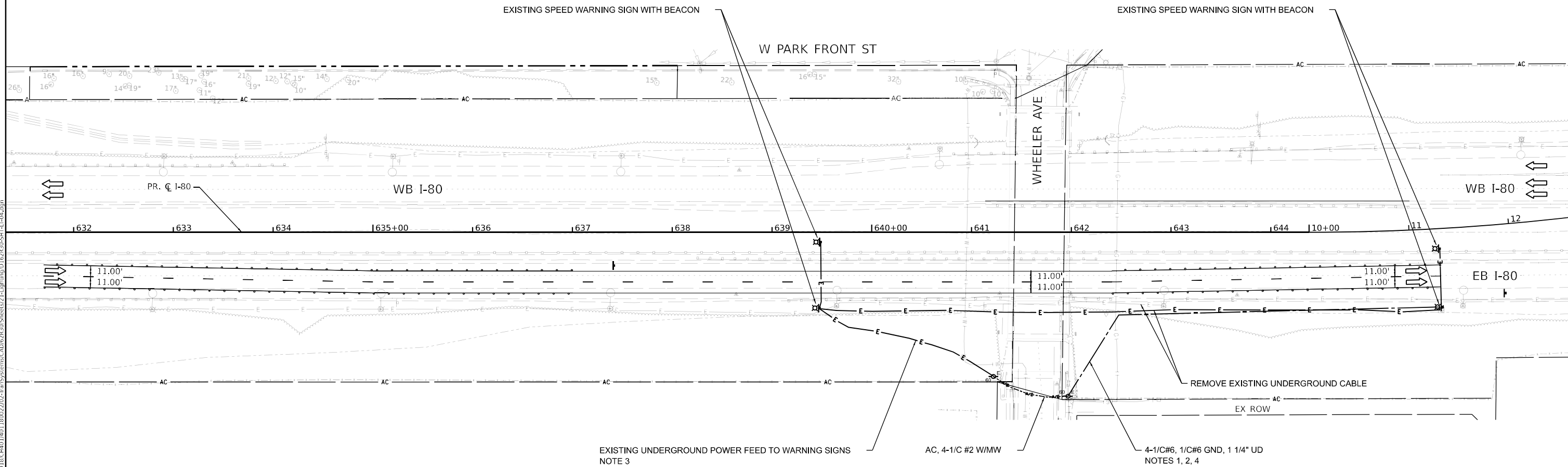

SCALE IN FEET



USER NAME = mostafan	DESIGNED - MAE	REVISED -
DRAWN - CAM	REVISIONS -	
PLOT SCALE = 100,000 ' / in.	CHECKED - TJL	REVISED -
PLOT DATE = 8/11/2022	DATE - 8/12/2022	REVISED -

**STATE OF ILLINOIS  
DEPARTMENT OF TRANSPORTATION**

**WHEELER AVENUE OVER F.A.I. ROUTE 80  
SIGN BEACON TEMPORARY WIRING**

SCALE: 1"=50' SHEET 4 OF 7 SHEETS STA. 631+32 TO STA. 14+00

F.A.U. RTE.	SECTION	COUNTY	TOTAL SHEETS	SHEET NO.
340	FBI 80 21 STRUCTURE 9	WILL	130	54
CONTRACT NO. 62R30				
ILLINOIS FED. AID PROJECT				

MODEL: Default  
 FILE: \\miller-pc\projects\trans\scorp\p11\h051\ED\Documents\proj\kls\_2018\CH401\401\_100027\02-Traffic\Systems\CAD\2023\Sheet21-Lighting\21-Lighting.dwg  
 2023/08/11 10:00:00 AM

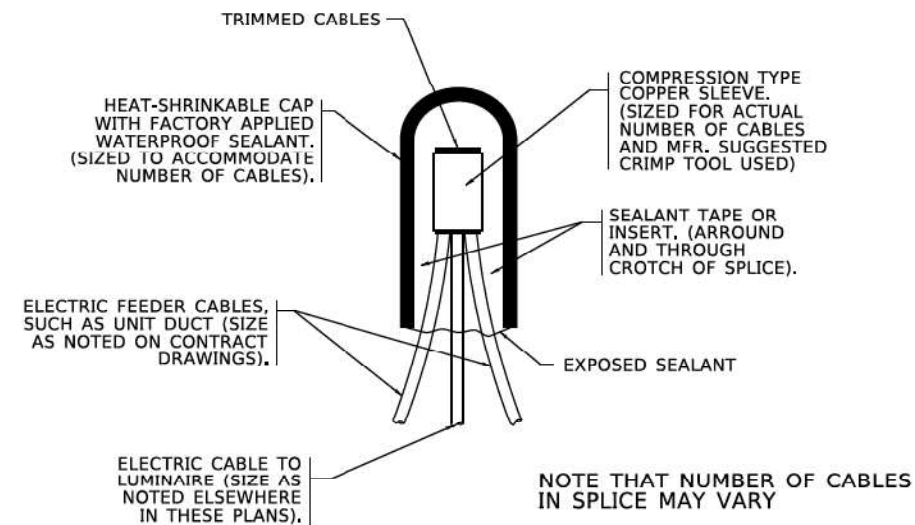

**TYPICAL SPLICE DETAIL**  
**N.T.S.**

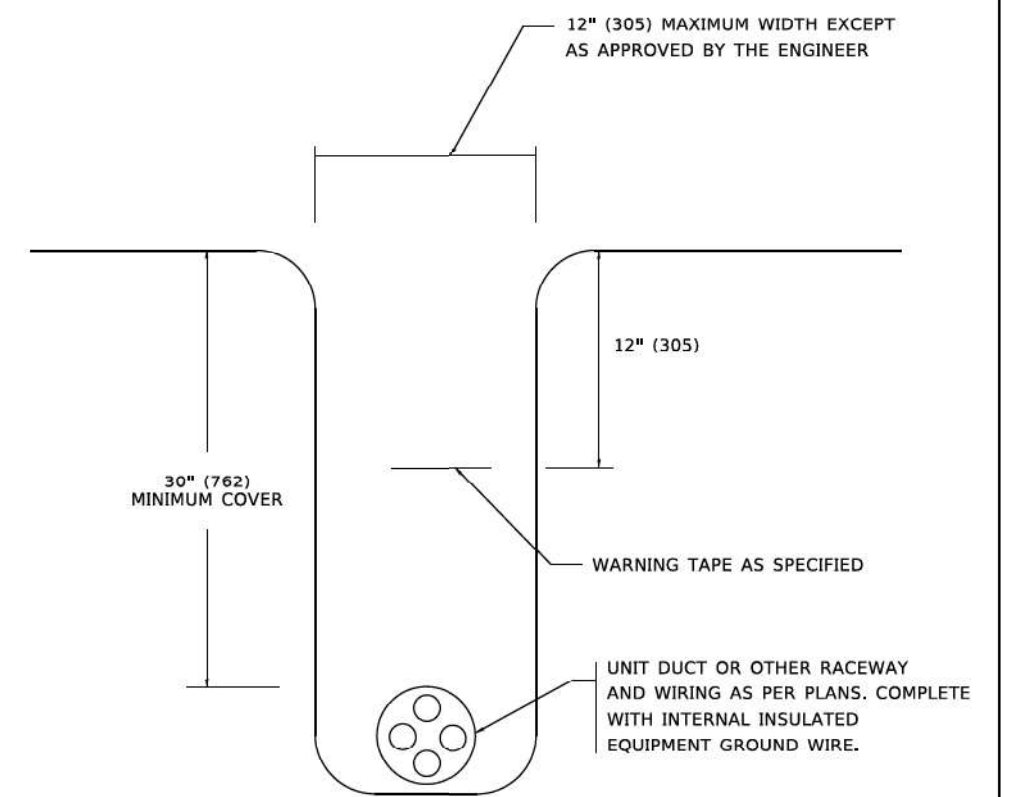

**TYPICAL WIRING IN TRENCH DETAIL**  
**N.T.S.**

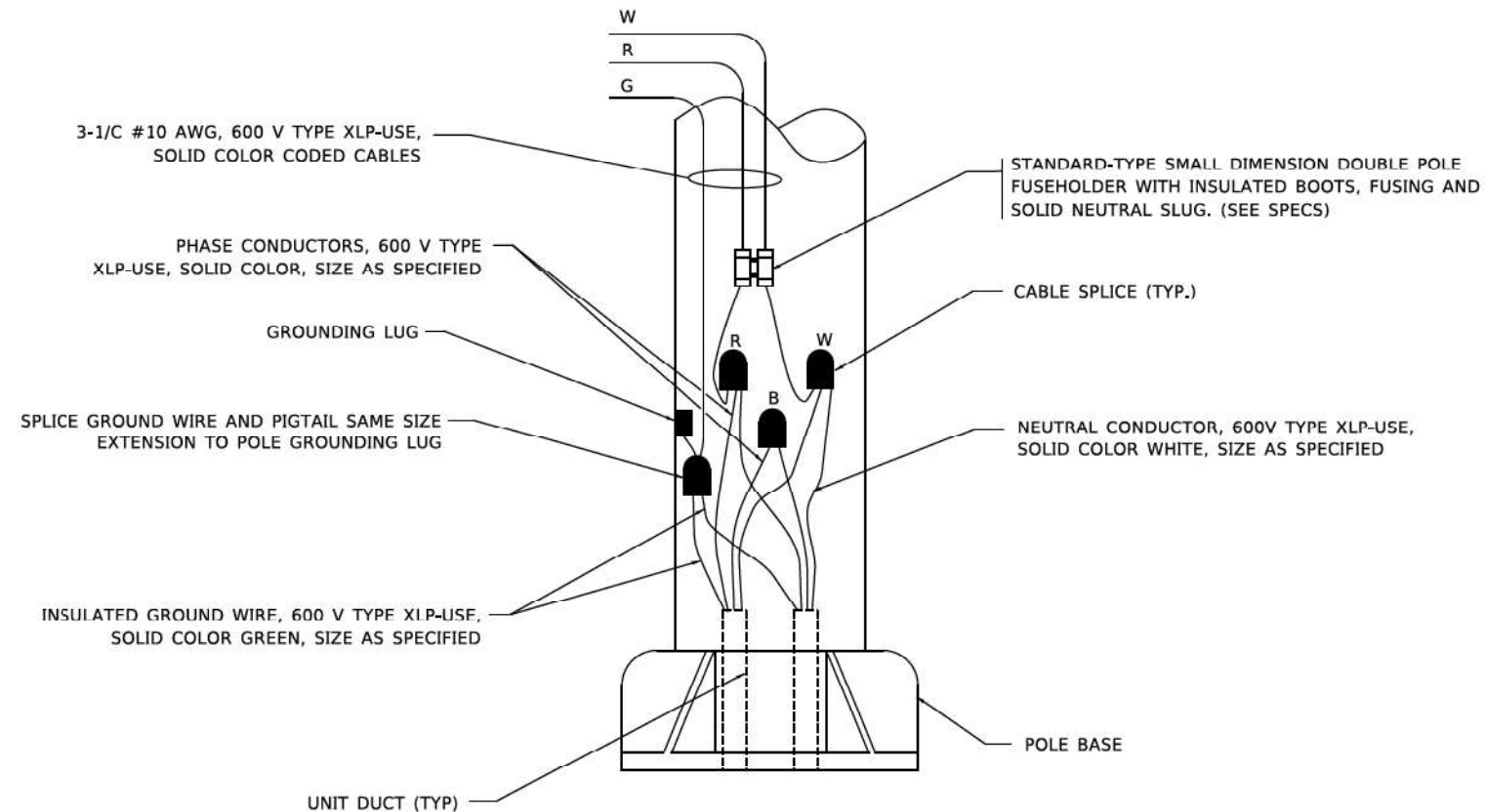

**POLE WIRING DETAIL**  
**N.T.S.**

MODEL: Default FILE: M:\aecom\pwworkspace\62282181\AECOM\TRANSPORTATION\PROJECTS\2018\CH401\40110002\02-TrafficSystems\CAD\2023\Sheet221-Lighting\Sheet221-Lighting.dgn PROJECT: D:\Projects\62282181\02-TrafficSystems\CAD\2023\Sheet221-Lighting\Sheet221-Lighting.dgn

USER NAME = keya			DESIGNED -	REVISED - 02/04/2020	<b>STATE OF ILLINOIS DEPARTMENT OF TRANSPORTATION</b>	<b>MISC. ELECTRICAL DETAILS SHEET A</b>		F.A.U. RTE.	SECTION	COUNTY	TOTAL SHEETS	SHEET NO.		
DRAWN -			CHECKED -	REVISED -				SCALE: NONE SHEET 1 OF 1 SHEETS STA. TO STA.						
PLOT SCALE = 50,000' / in.			DATE - 08/08/2003	REVISED -				85-702 CONTRACT NO. ILLINOIS FED. AID PROJECT						
PLOT DATE = 3/2/2020														

MODEL: Default FILE: M:\aecom\pwworkspace\62282181\AECOM\TRANSPORTATION\PROJECTS\2018\CH401\40110002\02-TrafficSystems\CAD\2023\Sheet222-Lighting\Sheet222-Lighting.dgn PROJECT: D:\Projects\62282181\02-TrafficSystems\CAD\2023\Sheet222-Lighting\Sheet222-Lighting.dgn

<b>AECOM</b> 303 EAST WACKER DRIVE, SUITE 1400 CHICAGO, IL 60601-4276 PHONE: (312) 375-7700 FAX: (312) 373-6800			USER NAME = mostafan	DESIGNED - MAE	REVISED -	<b>STATE OF ILLINOIS DEPARTMENT OF TRANSPORTATION</b>	<b>WHEELER AVENUE OVER F.A.I. ROUTE 80 LIGHTING DETAILS</b>		F.A.U. RTE.	SECTION	COUNTY	TOTAL SHEETS	SHEET NO.		
			DRAWN - CAM	CHECKED - TJL	REVISED -				SCALE: SHEET 5 OF 7 SHEETS STA. TO STA.						
PLOT SCALE = 100,000' / in.			DATE - 8/12/2022	REVISED -	340 FAI 80 21 STRUCTURE 9 WILL 130 55 CONTRACT NO. 62R30 ILLINOIS FED. AID PROJECT										
PLOT DATE = 8/10/2022															

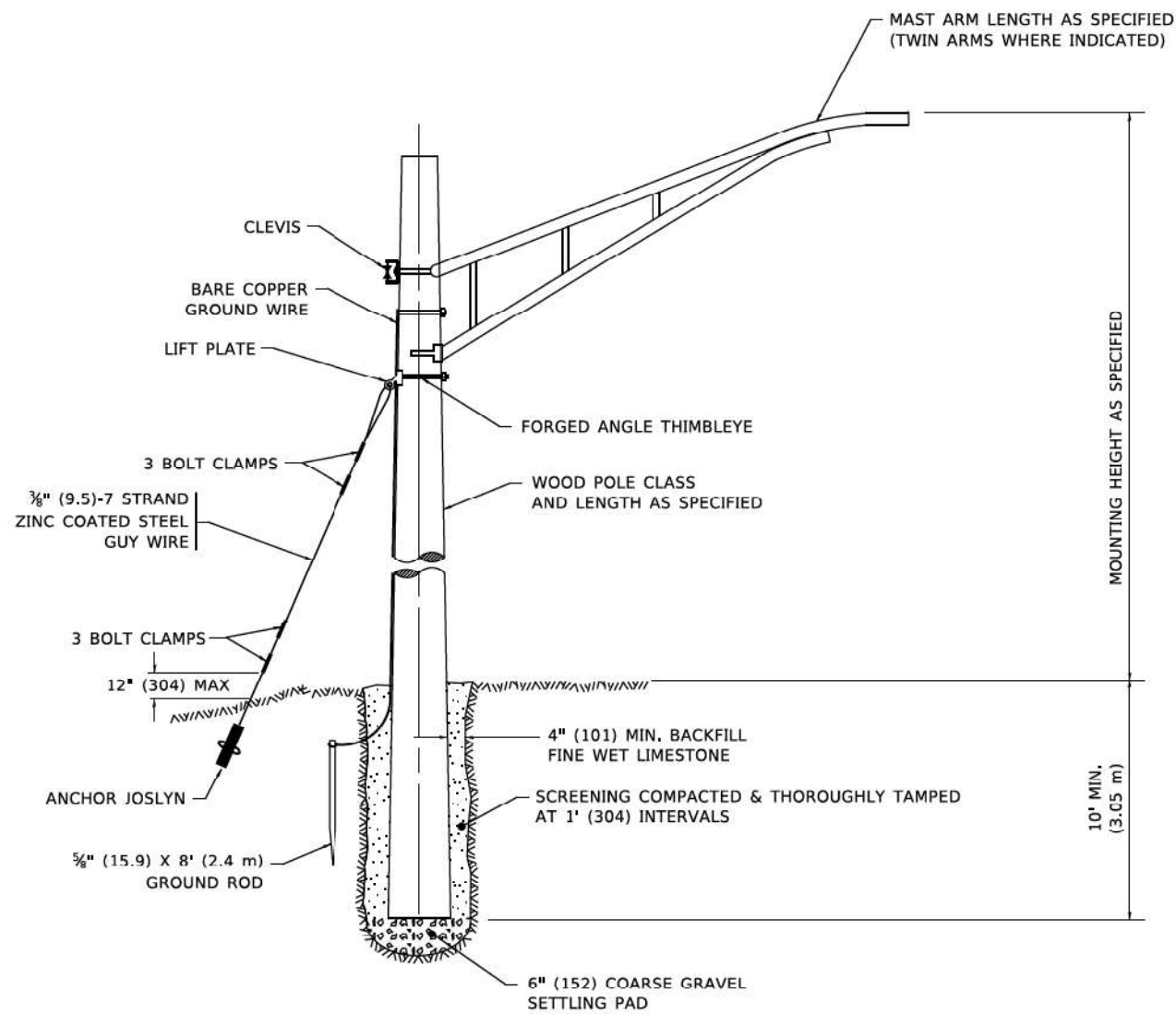

**TEMPORARY LIGHT POLE DETAIL**

- NOTE:
1. ALL DIMENSIONS IN INCHES (MILLIMETERS) UNLESS OTHERWISE INDICATED.
  2. MAST ARM SHALL BE RATED FOR THE SPECIFIED MOUNTING HEIGHT.

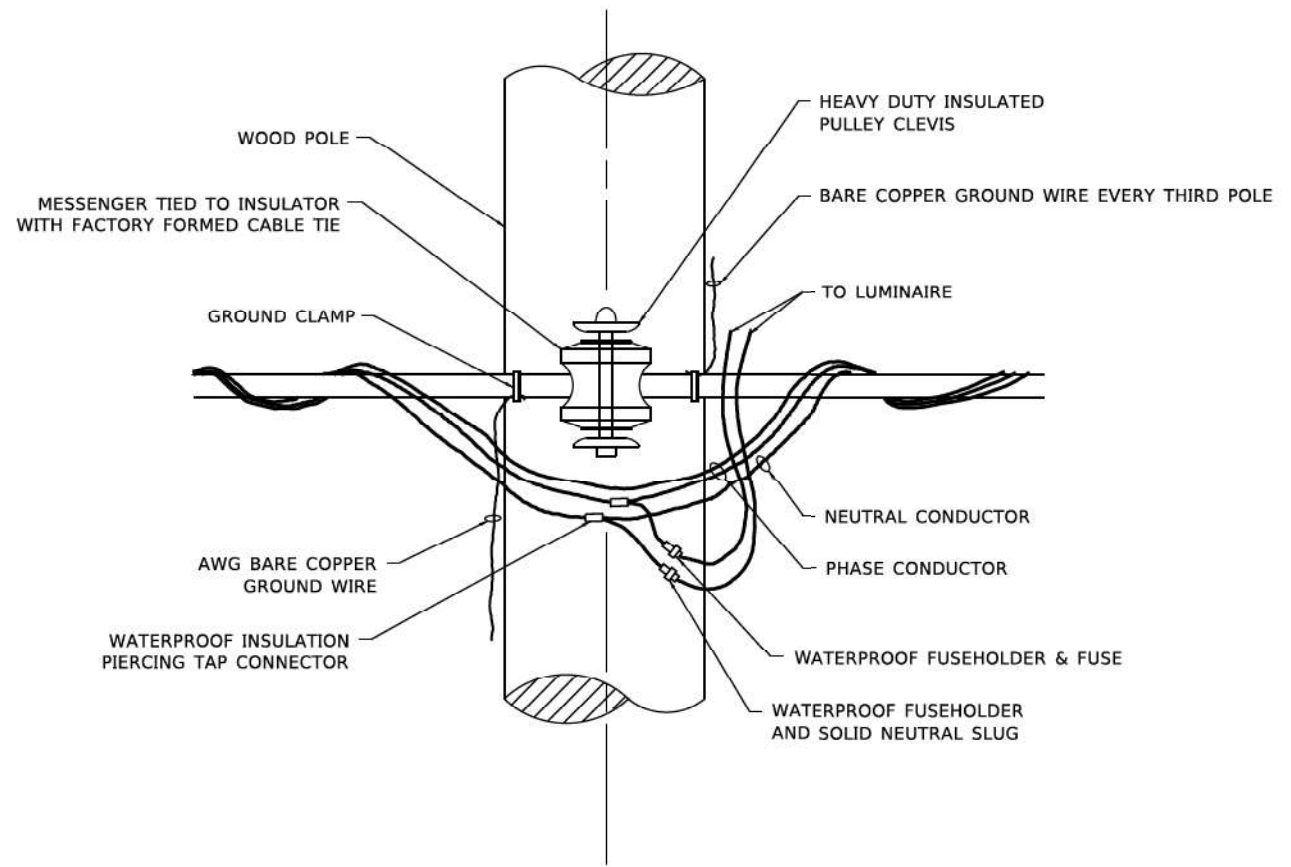

**TEMPORARY LIGHT POLE ATTACHMENT DETAIL**

MODEL: Default  
 FILE NAME: p:\projects\pwwd\071\Documents\18\DOT - Office\Drawings\18\Project\18\181222\22-34\CAD\DWG\CAD\Sheet\181222.dwg

USER NAME = footemf	DESIGNED -	REVISED - 08-08-03
PLOT SCALE = 50,000' / in.	DRAWN -	REVISED - R.T. 07-26-16
PLOT DATE = 4/19/2019	CHECKED -	REVISED -
	DATE -	REVISED -

**STATE OF ILLINOIS  
DEPARTMENT OF TRANSPORTATION**

<b>TEMPORARY LIGHT POLE DETAILS</b>			
SCALE: NONE	SHEET 1	OF 1	SHEETS STA. TO STA.

F.A.U. RTE.	SECTION	COUNTY	TOTAL SHEETS	SHEET NO.
	<b>BE-800</b>			
CONTRACT NO.			ILLINOIS FED. AID PROJECT	



USER NAME = mostafan	DESIGNED - MAE	REVISED -
PLOT SCALE = 100,000' / in.	DRAWN - CAM	REVISED -
PLOT DATE = 8/10/2022	CHECKED - TJL	REVISED -
	DATE - 8/12/2022	REVISED -

**STATE OF ILLINOIS  
DEPARTMENT OF TRANSPORTATION**

<b>WHEELER AVENUE OVER F.A.I. ROUTE 80 LIGHTING DETAILS</b>			
SCALE:	SHEET 6	OF 7	SHEETS STA. TO STA.

F.A.U. RTE.	SECTION	COUNTY	TOTAL SHEETS	SHEET NO.
340	FAI 80 21 STRUCTURE 9	WILL	130	56
CONTRACT NO. 62R30			ILLINOIS FED. AID PROJECT	



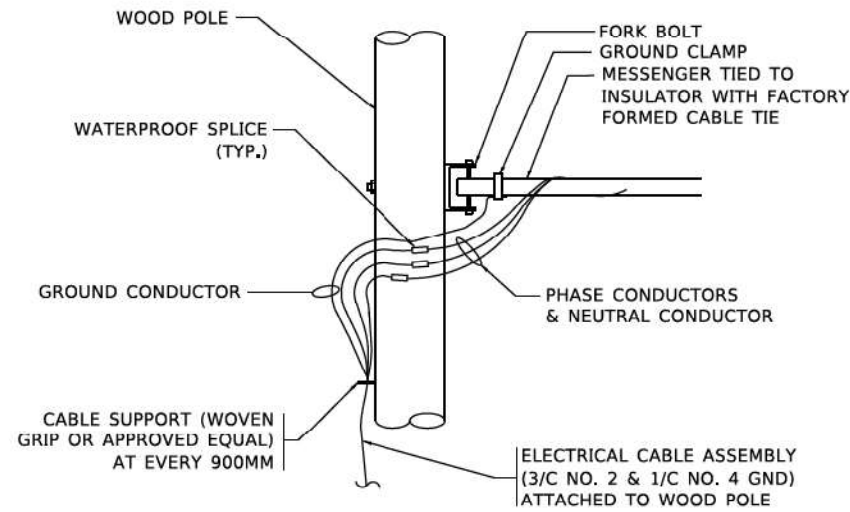

**AERIAL CABLE CONNECTION DETAIL**  
N.T.S.

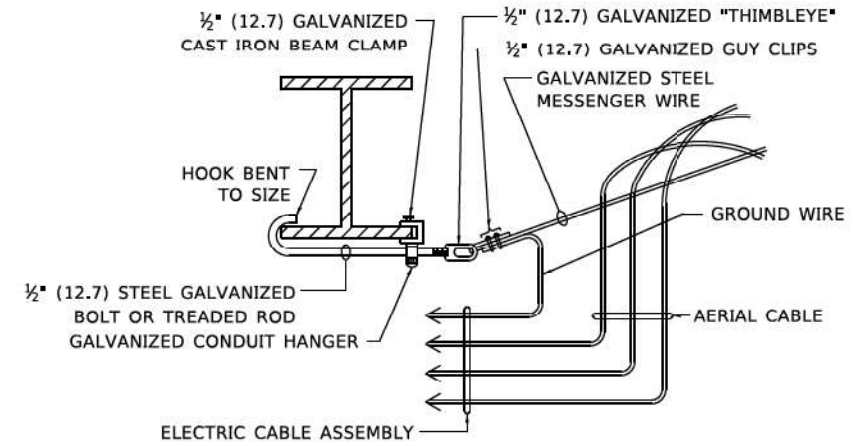

**AERIAL CABLE ATTACHED TO STRUCTURE**  
NOT TO SCALE

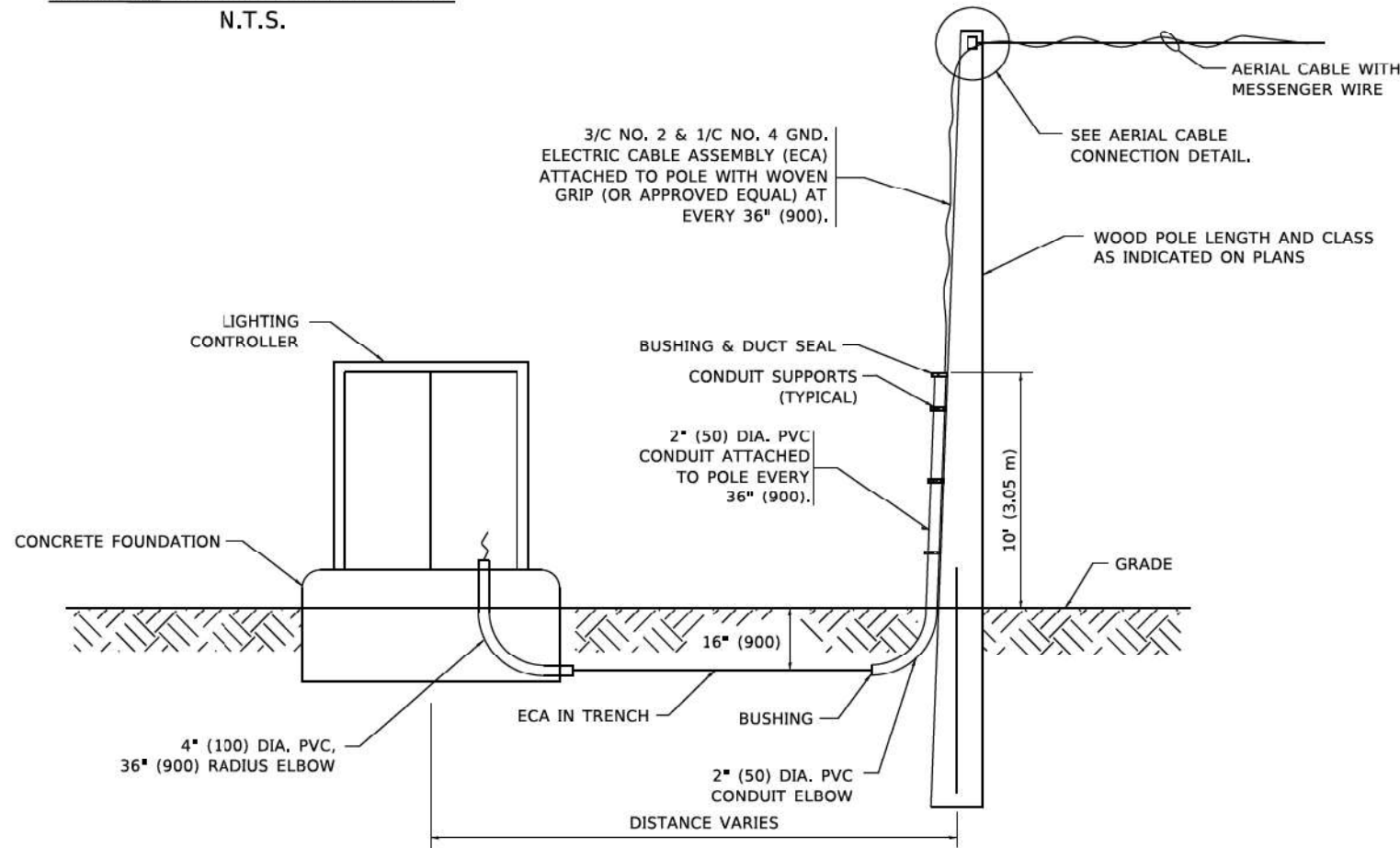

**WOOD POLE TO LIGHTING CONTROLLER WIRING CONNECTION DETAIL**  
N.T.S.

**NOTES:**

1. ALL DIMENSIONS IN INCHES (MILLIMETERS) UNLESS OTHERWISE INDICATED.
2. SEE PROPOSED LIGHTING PLAN FOR CONDUIT, CABLE AND ROUTING.
3. THE CONTRACTOR SHALL PROVIDE INTERMEDIATE SUPPORTS TO MAINTAIN MINIMUM CLEARANCES. REFER TO AERIAL AERIAL CABLE ATTACHED TO STRUCTURE DETAIL.
4. COST OF SPLICES AND MOUNTING HARDWARE SHALL BE INCLUDED IN THE UNIT PRICE FOR AERIAL CABLE.

MODEL: Default  
 FILE NAME: p:\projects\trans\scorp\p11\h05\TEDE\Documents\proj\chicago\_2018\CH401\401\_10002702-TR\sys\com\CAD\02R30\Sheet21-Lighting\02R30-SHT-L-07.dgn  
 PROJECT: I:\projects\trans\scorp\p11\h05\TEDE\Documents\proj\chicago\_2018\CH401\401\_10002702-TR\sys\com\CAD\02R30\Sheet21-Lighting\02R30-SHT-L-07.dgn  
 USER: mostafan

USER NAME = footemf	DESIGNED -	REVISED - 08-08-03
PLOT SCALE = 50,0000 ' / in.	DRAWN -	REVISED -
PLOT DATE = 4/19/2019	CHECKED -	REVISED -
	DATE -	REVISED -

<b>STATE OF ILLINOIS DEPARTMENT OF TRANSPORTATION</b>	
<b>TEMPORARY AERIAL CABLE INSTALLATION</b>	
SCALE: NONE	SHEET 1 OF 1 SHEETS STA. TO STA.

F.A.U. RTE.	SECTION	COUNTY	TOTAL SHEETS	SHEET NO.
	<b>BE-801</b>			
CONTRACT NO.			ILLINOIS FED. AID PROJECT	



USER NAME = mostafan	DESIGNED - MAE	REVISED -
PLOT SCALE = 100,000 ' / in.	DRAWN - CAM	REVISED -
PLOT DATE = 8/10/2022	CHECKED - TJL	REVISED -
	DATE - 8/12/2022	REVISED -

<b>STATE OF ILLINOIS DEPARTMENT OF TRANSPORTATION</b>	
<b>WHEELER AVENUE OVER F.A.I. ROUTE 80 LIGHTING DETAILS</b>	
SCALE:	SHEET 7 OF 7 SHEETS STA. TO STA.

F.A.U. RTE.	SECTION	COUNTY	TOTAL SHEETS	SHEET NO.
340	FAI 80 21 STRUCTURE 9	WILL	130	57
CONTRACT NO. 62R30			ILLINOIS FED. AID PROJECT	

Benchmark: Set cut square in northwesterly corner of southerly overhead sign foundation for sign "East Indiana", "Exit 131 Center St" on the south side of east bound I-80 @ Center Street exit ramp; Elev. 619.468.

Existing Structure: SN 099-0175, built in 1966 as FAI Rte. 80, Project I-80-4 (22) 133, Section 99-3. The structure has a total of 4 spans with continuous steel stringers that support the deck. The original substructure consisted of cast-in-place reinforced concrete stub abutments and multiple column grade separation piers supported on spread footings. The structure was repaired in 2002 under Project ACBHI-80-4(180)133, Section 99-3HB-1. The improvement consisted of bridge deck replacement, superstructure and substructure rehabilitation, addition of shear studs to steel beams, and approach roadway reconstruction. The abutments were converted to a semi-integral type abutment. The bridge measures 237'-6" back to back abutments, 60'-0" out to out width with no skew at abutments and 1°04'42" skew at piers.

Traffic Control: Traffic will be detoured during the construction. Traffic will be maintained along I-80.

Existing bridge Fence Railing to be salvaged & delivered to a location as specified in General Notes on Sheet S-2.

**DESIGN SPECIFICATIONS**

2020 AASHTO LRFD Bridge Design Specifications, 9th Edition

**DESIGN STRESSES**

**FIELD UNITS**

$f'_c = 3,500$  psi  
 $f'_c = 4,000$  psi (Superstructure)  
 $f_y = 60,000$  psi (Reinforcement)  
 $f_y = 50,000$  psi (M270 Grade 50)

**LOADING HL-93**

Allow 50#/sq. ft. for future wearing surface.

**SEISMIC DATA**

Seismic Performance Zone (SPZ) = 1  
 Design Spectral Acceleration at 1.0 sec. (SD1) = 0.068g  
 Design Spectral Acceleration at 0.2 sec. (SDS) = 0.126g  
 Soil Site Class = C

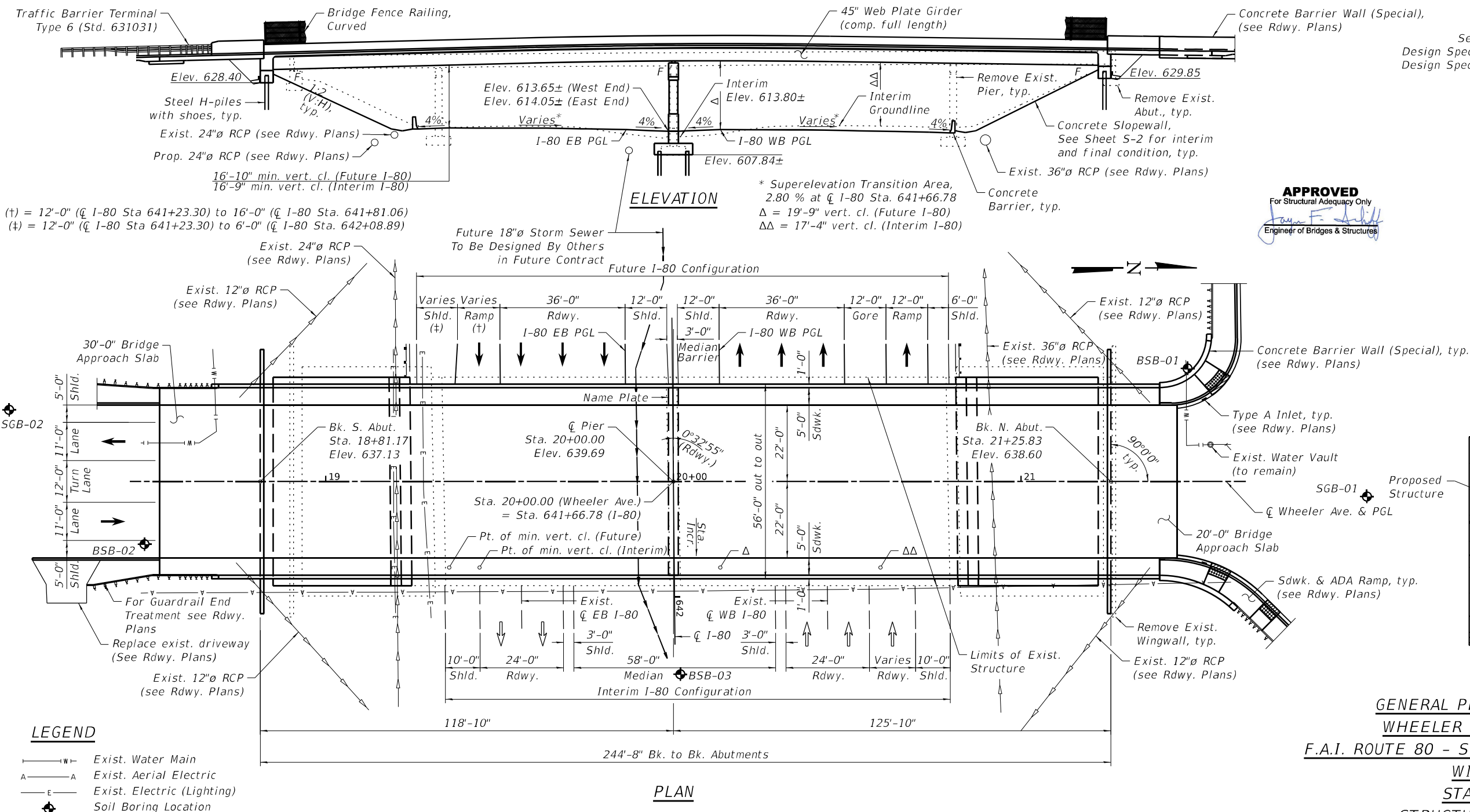

**APPROVED**  
 For Structural Adequacy Only  
 Jay F. [Signature]  
 Engineer of Bridges & Structures

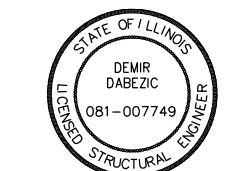

Davin Dabecic 07/22/2022  
 DEMIR DABEZIC DATE  
 LICENSE EXPIRES: 11/30/2022

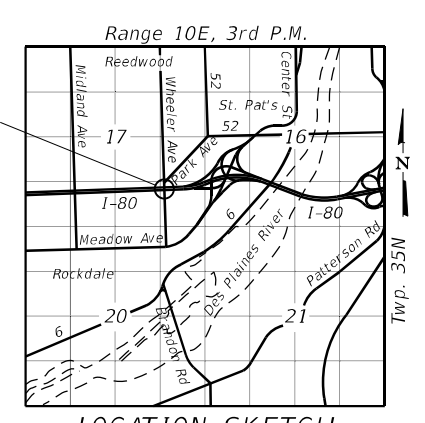

**GENERAL PLAN AND ELEVATION**  
**WHEELER AVENUE OVER I-80**  
**F.A.I. ROUTE 80 - SEC. FAI 80 21 STRUCTURE 9**  
**WILL COUNTY**  
**STA. 641+66.78**  
**STRUCTURE NO. 099-8324**

**LEGEND**

—W—	Exist. Water Main
—A—	Exist. Aerial Electric
—E—	Exist. Electric (Lighting)
⊕	Soil Boring Location

MODEL: Sheet  
 FILE NAME: pw://transystems-pw.bentley.com/TRANSSYS/PROJ/PW1-HOSTED/Projects\_2018/CH401/40118002202-Transystems/CAD/62R30/Sheets/S-3-Structural/099-8324-CR-03-001-GPE.dgn  
 9/28/2022 10:57:41 AM



USER NAME =	DESIGNED - MK	REVISED -
PLOT SCALE =	CHECKED - DD	REVISED -
PLOT DATE =	DRAWN - MK	REVISED -
	CHECKED - DD	REVISED -

STATE OF ILLINOIS  
 DEPARTMENT OF TRANSPORTATION

F.A.I. RTE.	SECTION	COUNTY	TOTAL SHEETS	SHEET NO.
80	FAI 80 21 STRUCTURE 9	WILL	130	58

CONTRACT NO. 62R30	
ILLINOIS	FED. AID PROJECT

SHEET S-1 OF S-31 SHEETS

**GENERAL NOTES**

- Fasteners shall be ASTM F3125 Grade A325 Type 1, hot dipped galvanized bolts. Bolts 1/2" Ø, holes 5/16" Ø, unless otherwise noted.
- Calculated weight of Structural Steel  
M270 Grade 50 = 488,230 lbs.  
M270 Grade 36 = 31,320 lbs.
- No field welding is permitted except as specified in the contract documents.
- Reinforcement bars designated (E) shall be epoxy coated.
- Bearing seat surfaces shall be constructed or adjusted to the designated elevations within a tolerance of 1/8 inch (0.01 ft.). Adjustment shall be made either by grinding the surface or by shimming the bearings.
- Concrete Sealer shall be applied to the designated areas of the pier.
- All new structural steel shall be metallized. See Special Provision for "Metallizing of Structural Steel."
- The existing structural steel coating contains lead. The Contractor shall take appropriate precautions to deal with the presence of lead on this project.
- Slope wall shall be reinforced with welded wire fabric, 6 in. x 6 in. - W4.0 x W4.0, weighing 58 lbs. per 100 sq. ft.
- Salvage the existing bridge Fence Railing and deliver to the District Bridge Yard at 1101 Biesterfield Rd, Elk Grove IL 60007. Contact Steve Mastny (847-956-1501).
- The limits of the Protective Shield are the out to out width (60'-0") and entire length (235'-6") of the existing superstructure.
- For Bridge Mount Sign Structures, see Roadway Plans.

**TOTAL BILL OF MATERIAL**

ITEM	UNIT	SUPER	SUB	TOTAL
Removal of Existing Structures No. 1	Each			1.0
Protective Shield	Sq Yd	1,570		1,570
Structure Excavation	Cu Yd		715.0	715.0
Concrete Structures	Cu Yd		234.8	234.8
Concrete Superstructure	Cu Yd	554.9		554.9
Bridge Deck Grooving	Sq Yd	1,367		1,367
Protective Coat	Sq Yd	1,995		1,995
Concrete Superstructure (Approach Slab)	Cu Yd	148.3		148.3
Furnishing And Erecting Structural Steel	L Sum	1.0		1.0
Stud Shear Connectors	Each	4,998		4,998
Reinforcement Bars, Epoxy Coated	Pound	170,970	39,920	210,890
Bridge Fence Railing, Curved	Foot	486		486
Slope Wall 4 Inch	Sq Yd		299	299
Furnishing Steel Piles Hp14X89	Foot		789	789
Driving Piles	Foot		789	789
Test Pile Steel Hp14X89	Each		3	3
Pile Shoes	Each		30	30
Name Plates	Each	1		1
Anchor Bolts, 1"	Each	28		28
Anchor Bolts, 1 1/2"	Each	14		14
Granular Backfill For Structures	Cu Yd		232.2	232.2
Concrete Sealer	Sq Ft		2,110	2,110
Pipe Underdrains For Structures 4"	Foot		160	160
Geocomposite Wall Drain	Sq Yd		124	124

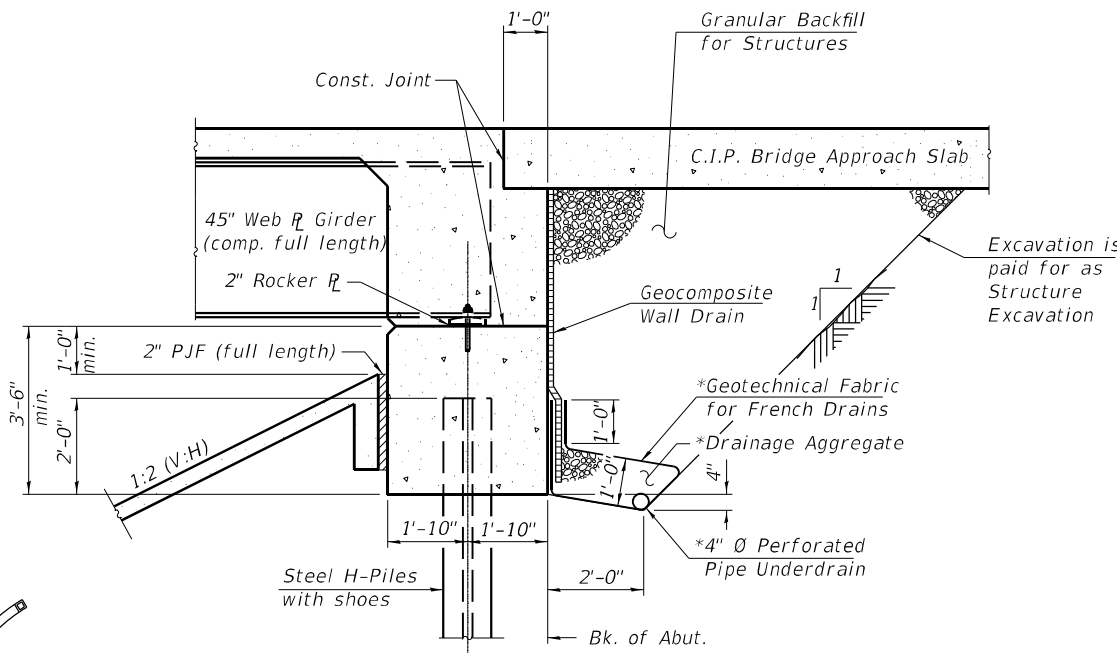

**SECTION THRU INTEGRAL ABUTMENT**

\*Included in the cost of Pipe Underdrains for Structures.

**NOTES:**

All drainage system components shall extend to 2'-0" from the end of each wingwall except an outlet pipe shall extend until intersecting with the side slopes. The pipes shall drain into concrete headwalls. (See Article 601.05 of the Standard Specifications and Highway Standard 601101).

Remove and salvage existing bridge Fence Railing (See Note 10)

Remove existing structure

**BARRIER FENCE REMOVAL DETAIL**

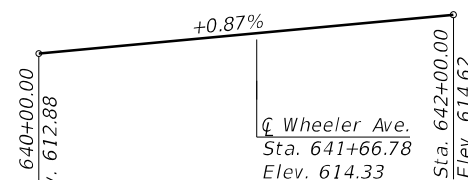

**FUTURE I-80 PROFILE GRADE**

(Along I-80 EB & I-80 WB PGL's)

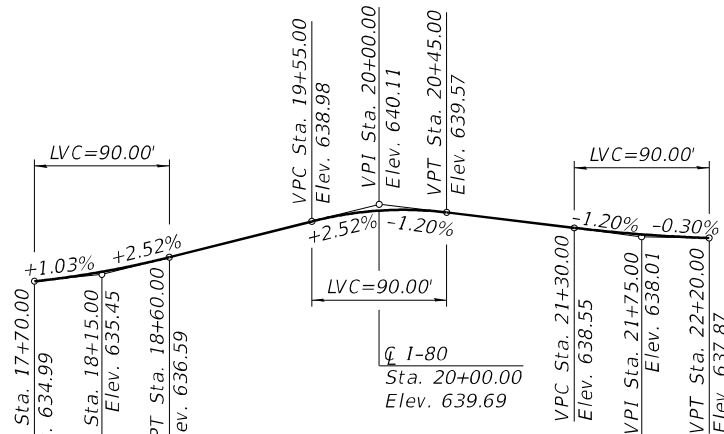

**WHEELER AVE. PROFILE GRADE**

(Along Center Roadway)

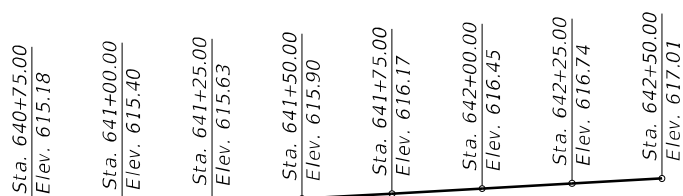

**EXISTING EB I-80 PROFILE GRADE**

(Along Exist. Center EB I-80)

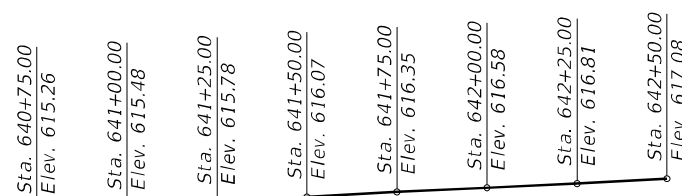

**EXISTING WB I-80 PROFILE GRADE**

(Along Exist. Center WB I-80)

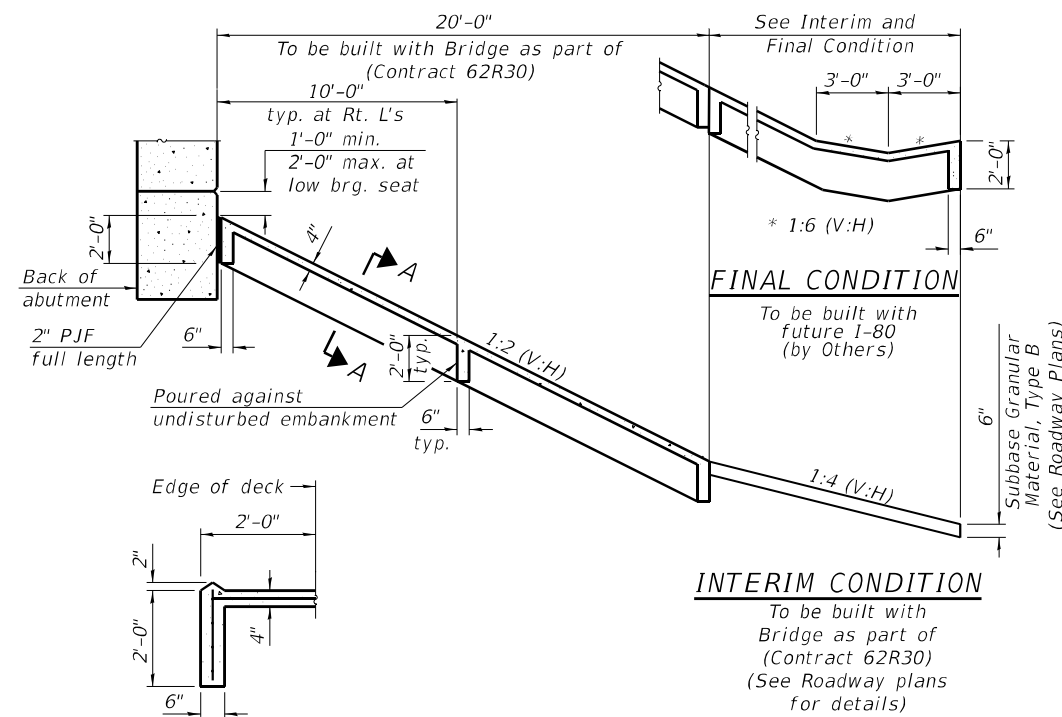

**SECTION A-A**

**SECTION THRU CONCRETE SLOPEWALL**

STATION 641+66.78  
BUILT 202\_ BY  
STATE OF ILLINOIS  
F.A.I. RT. 80  
SEC. FAI 80 21 STRUCTURE 9  
LOADING HL-93  
STRUCTURE NO. 099-8324

**NAME PLATE**  
See Std. 515001

**INDEX OF SHEETS**

- S-1 General Plan and Elevation
- S-2 General Data
- S-3 Substructure Layout
- S-4 Top of Slab Elevations I
- S-5 Top of Slab Elevations II
- S-6 Top of Slab Elevations III
- S-7 Top of Slab Elevations IV
- S-8 Top of South Approach Slab Elevations
- S-9 Top of North Approach Slab Elevations
- S-10 Superstructure Plan and Cross Section
- S-11 Parapet Elevations
- S-12 Superstructure Details
- S-13 Diaphragm Details
- S-14 South Approach Slab Plan
- S-15 South Approach Slab Details
- S-16 North Approach Slab Plan
- S-17 North Approach Slab Details
- S-18 Bridge Fence Railing, Curved
- S-19 Framing Plan & Girder Elevation
- S-20 Girder Moment & Reaction Tables
- S-21 Girder Camber Diagram
- S-22 Steel Details
- S-23 Bearing Details
- S-24 Abutment Plan & Elevation
- S-25 Abutment Details
- S-26 Pier Plan & Elevation
- S-27 Pier Details
- S-28 HP Pile Details
- S-29 Soil Boring Logs I
- S-30 Soil Boring Logs II
- S-31 Soil Boring Logs III

MODEL: Sheet  
FILE NAME: pw://transys/pw-bentley.com:TRANSYS/CP-PW1-HOSTED/Projects\_2018/CH401/401-18002202-Transys/CAD/62R30/Sheets/2-3-Structural/099-8324-CP-03-002-General.dgn  
9/28/2022 10:57:49 AM



USER NAME =	DESIGNED - MK	REVISED -
PLOT SCALE =	CHECKED - DD	REVISED -
PLOT DATE =	DRAWN - MK	REVISED -
	CHECKED - DD	REVISED -

**STATE OF ILLINOIS  
DEPARTMENT OF TRANSPORTATION**

**GENERAL DATA  
STRUCTURE NO. 099-8324**

SHEET S-2 OF S-31 SHEETS

F.A.I. RTE.	SECTION	COUNTY	TOTAL SHEETS	SHEET NO.
80	FAI 80 21 STRUCTURE 9	WILL	130	59
CONTRACT NO. 62R30				
		ILLINOIS   FED. AID PROJECT		

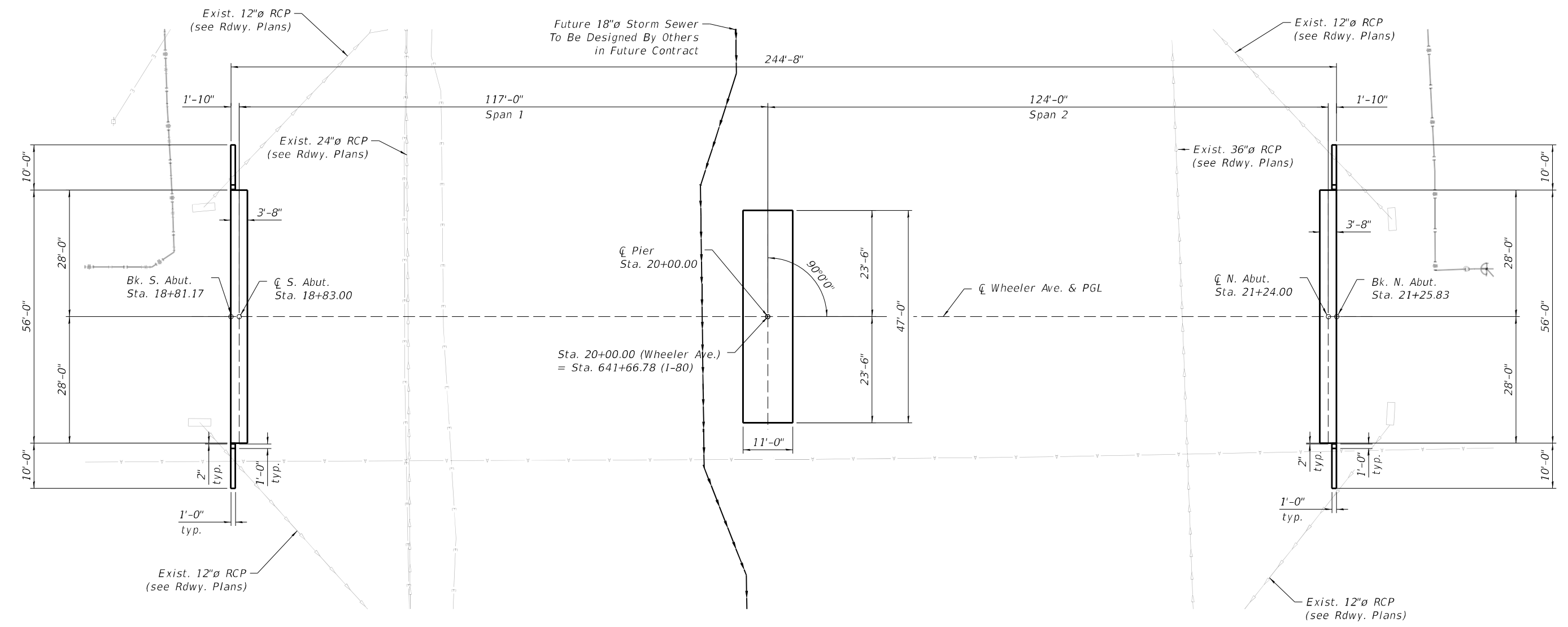
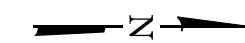

SUBSTRUCTURE LAYOUT

**LEGEND**

—W—	Exist. Water Main
—A—	Exist. Aerial Electric
—E—	Exist. Electric (Lighting)
—S—	Exist. Storm Sewer

MODEL: Sheet  
 FILE NAME: pw://transsystems-pw.bentley.com:TRANSSYSTEMS/PW1-HOSTED/Documents/Projects\_2018/CH401/401180022/02-TransSystems/CAD/62R30/Sheets/2-Structural/099-8324-CR-03-003-Sub-Layout.dgn  
 9/28/2022 10:58:39 AM



USER NAME =	DESIGNED - MK	REVISED -
	CHECKED - DD	REVISED -
PLOT SCALE =	DRAWN - MK	REVISED -
PLOT DATE =	CHECKED - DD	REVISED -

**STATE OF ILLINOIS**  
**DEPARTMENT OF TRANSPORTATION**

**SUBSTRUCTURE LAYOUT**  
**STRUCTURE NO. 099-8324**

SHEET S-3 OF S-31 SHEETS

F.A.I. RTE.	SECTION	COUNTY	TOTAL SHEETS	SHEET NO.
80	FAI 80 21 STRUCTURE 9	WILL	130	60
			CONTRACT NO. 62R30	
		ILLINOIS	FED. AID PROJECT	

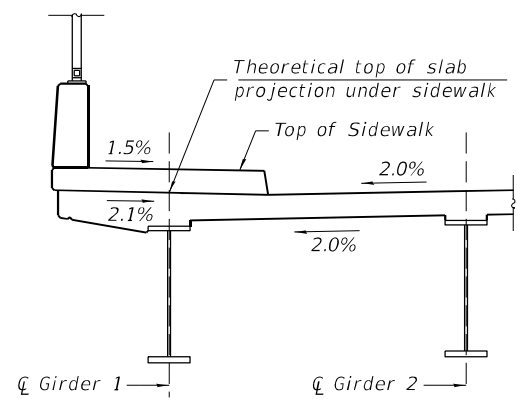

LOCATION OF ELEVATION UNDER WEST SIDEWALK

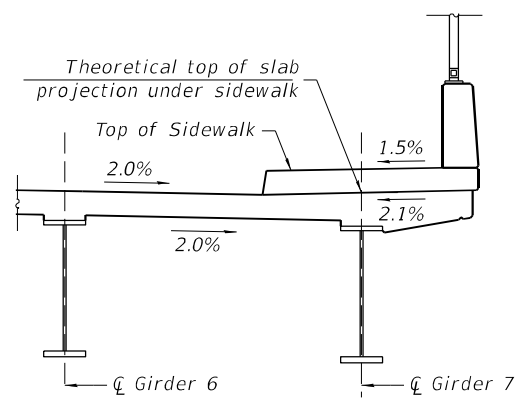

LOCATION OF ELEVATION UNDER EAST SIDEWALK

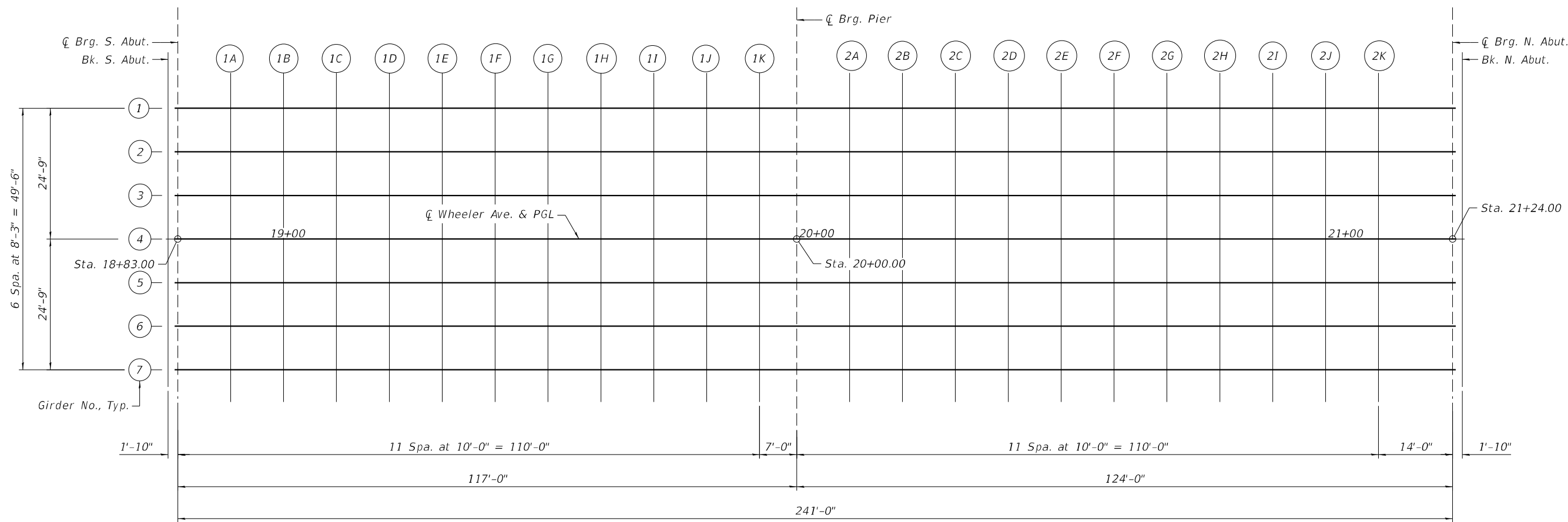

PLAN

MODEL: Sheet  
 FILE NAME: pw://transystems-pw.bentley.com:TRANSSYSTEMS/Projects\_2018/CH401/40118002202-Transystems/CAD/62R30/Sheets/2-Structural/099-8324-CR-03-004-TOS\_I\_Elev.dgn  
 9/28/2022 10:58:47 AM



USER NAME =	DESIGNED - MK	REVISED -
	CHECKED - DD	REVISED -
PLOT SCALE =	DRAWN - MK	REVISED -
PLOT DATE =	CHECKED - DD	REVISED -

STATE OF ILLINOIS  
 DEPARTMENT OF TRANSPORTATION

TOP OF SLAB ELEVATIONS I  
 STRUCTURE NO. 099-8324

SHEET S-4 OF S-31 SHEETS

F.A.I. RTE.	SECTION	COUNTY	TOTAL SHEETS	SHEET NO.
80	FAI 80 21 STRUCTURE 9	WILL	130	61
			CONTRACT NO. 62R30	
		ILLINOIS	FED. AID PROJECT	

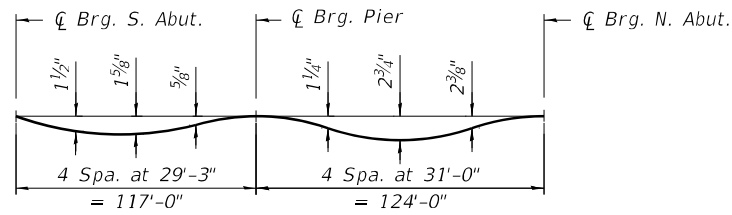

**DEAD LOAD DEFLECTION DIAGRAM**  
(Includes weight of concrete only.)

Note:  
The above deflections are not to be used in the field if the engineer is working from the grade elevations adjusted for dead load deflections as shown below and Sheets S-6 & S-7.

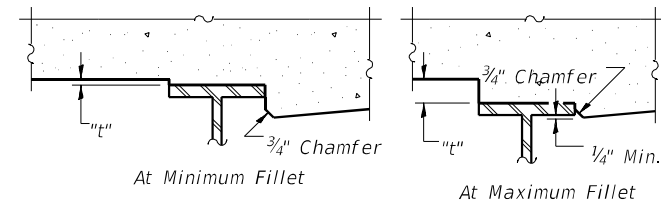

To determine "t": After all structural steel has been erected, elevations of the top flanges of the beams shall be taken at intervals shown below. These elevations subtracted from the "Theoretical Grade Elevations Adjusted for Dead Load Deflection" shown below and Sheets S-6 & S-7, minus slab thickness, equals the fillet heights "t" above top flange of beams.

**FILLET HEIGHTS**

**GIRDER 1**

Location	Station	Offset	Theoretical Grade Elevations	Theoretical Grade Elevations Adjusted For Dead Load Deflection
Bk. S. Abut.	18+81.17	-24.75	636.83	636.83
C Brg. S. Abut.	18+83.00	-24.75	636.87	636.87
1A	18+93.00	-24.75	637.13	637.18
1B	19+03.00	-24.75	637.38	637.48
1C	19+13.00	-24.75	637.63	637.76
1D	19+23.00	-24.75	637.88	638.03
1E	19+33.00	-24.75	638.13	638.28
1F	19+43.00	-24.75	638.38	638.52
1G	19+53.00	-24.75	638.63	638.74
1H	19+63.00	-24.75	638.87	638.95
1I	19+73.00	-24.75	639.07	639.11
1J	19+83.00	-24.75	639.22	639.24
1K	19+93.00	-24.75	639.34	639.34
C Brg. Pier	20+00.00	-24.75	639.40	639.40
2A	20+10.00	-24.75	639.44	639.46
2B	20+20.00	-24.75	639.44	639.50
2C	20+30.00	-24.75	639.41	639.50
2D	20+40.00	-24.75	639.33	639.47
2E	20+50.00	-24.75	639.21	639.40
2F	20+60.00	-24.75	639.09	639.32
2G	20+70.00	-24.75	638.97	639.21
2H	20+80.00	-24.75	638.85	639.09
2I	20+90.00	-24.75	638.73	638.94
2J	21+00.00	-24.75	638.61	638.78
2K	21+10.00	-24.75	638.49	638.60
C Brg. N. Abut.	21+24.00	-24.75	638.32	638.32
Bk. N. Abut.	21+25.83	-24.75	638.30	638.30

**GIRDER 2**

Location	Station	Offset	Theoretical Grade Elevations	Theoretical Grade Elevations Adjusted For Dead Load Deflection
Bk. S. Abut.	18+81.17	-16.50	636.88	636.88
C Brg. S. Abut.	18+83.00	-16.50	636.92	636.92
1A	18+93.00	-16.50	637.18	637.23
1B	19+03.00	-16.50	637.43	637.53
1C	19+13.00	-16.50	637.68	637.81
1D	19+23.00	-16.50	637.93	638.08
1E	19+33.00	-16.50	638.18	638.33
1F	19+43.00	-16.50	638.43	638.57
1G	19+53.00	-16.50	638.68	638.79
1H	19+63.00	-16.50	638.92	639.00
1I	19+73.00	-16.50	639.12	639.16
1J	19+83.00	-16.50	639.27	639.29
1K	19+93.00	-16.50	639.39	639.39
C Brg. Pier	20+00.00	-16.50	639.45	639.44
2A	20+10.00	-16.50	639.49	639.51
2B	20+20.00	-16.50	639.49	639.55
2C	20+30.00	-16.50	639.46	639.55
2D	20+40.00	-16.50	639.38	639.52
2E	20+50.00	-16.50	639.26	639.45
2F	20+60.00	-16.50	639.14	639.37
2G	20+70.00	-16.50	639.02	639.26
2H	20+80.00	-16.50	638.90	639.14
2I	20+90.00	-16.50	638.78	638.99
2J	21+00.00	-16.50	638.66	638.83
2K	21+10.00	-16.50	638.54	638.65
C Brg. N. Abut.	21+24.00	-16.50	638.37	638.37
Bk. N. Abut.	21+25.83	-16.50	638.35	638.35

**GIRDER 3**

Location	Station	Offset	Theoretical Grade Elevations	Theoretical Grade Elevations Adjusted For Dead Load Deflection
Bk. S. Abut.	18+81.17	-8.25	637.00	637.00
C Brg. S. Abut.	18+83.00	-8.25	637.05	637.05
1A	18+93.00	-8.25	637.30	637.35
1B	19+03.00	-8.25	637.55	637.65
1C	19+13.00	-8.25	637.80	637.94
1D	19+23.00	-8.25	638.05	638.20
1E	19+33.00	-8.25	638.30	638.46
1F	19+43.00	-8.25	638.56	638.69
1G	19+53.00	-8.25	638.81	638.92
1H	19+63.00	-8.25	639.04	639.12
1I	19+73.00	-8.25	639.24	639.28
1J	19+83.00	-8.25	639.40	639.41
1K	19+93.00	-8.25	639.51	639.51
C Brg. Pier	20+00.00	-8.25	639.57	639.57
2A	20+10.00	-8.25	639.61	639.63
2B	20+20.00	-8.25	639.62	639.67
2C	20+30.00	-8.25	639.58	639.68
2D	20+40.00	-8.25	639.50	639.65
2E	20+50.00	-8.25	639.39	639.58
2F	20+60.00	-8.25	639.27	639.49
2G	20+70.00	-8.25	639.15	639.39
2H	20+80.00	-8.25	639.03	639.26
2I	20+90.00	-8.25	638.91	639.12
2J	21+00.00	-8.25	638.79	638.95
2K	21+10.00	-8.25	638.67	638.77
C Brg. N. Abut.	21+24.00	-8.25	638.50	638.50
Bk. N. Abut.	21+25.83	-8.25	638.48	638.48

**NOTES:**

Offset measured from C of Wheeler Ave.

MODEL: Sheet  
FILE NAME: pw://transystems-pw.bentley.com/TRANSSYSTEMS/PW1-HOSTED/Projects/2018/CH401/40118002202-Transystems/CAD/62R30/Sheets/S-3-Structural/099-8324-CR-03-005-TOS\_II\_Elev.dgn



USER NAME =	DESIGNED - MK	REVISED -
PLOT SCALE =	CHECKED - DD	REVISED -
PLOT DATE =	DRAWN - MK	REVISED -
	CHECKED - DD	REVISED -

STATE OF ILLINOIS  
DEPARTMENT OF TRANSPORTATION

TOP OF SLAB ELEVATIONS II  
STRUCTURE NO. 099-8324

SHEET S-5 OF S-31 SHEETS

F.A.I. RTE.	SECTION	COUNTY	TOTAL SHEETS	SHEET NO.
80	FAI 80 21 STRUCTURE 9	WILL	130	62
CONTRACT NO. 62R30				
ILLINOIS		FED. AID PROJECT		

MODEL: Sheet  
 FILE NAME: pw://transystems-pw.bentley.com/TRANSSCORP-PW1-HOSTED/Projects\_2018/CH401/40118002202-Transystems/CAD/62R30/SHEETS/2-Structural/099-8324-CP-03-006-TOS\_III\_Elev.dgn

**GIRDER 4 & PGL**

Location	Station	Offset	Theoretical Grade Elevations	Theoretical Grade Elevations Adjusted For Dead Load Deflection
Bk. S. Abut.	18+81.17	0	637.13	637.13
☉ Brg. S. Abut.	18+83.00	0	637.17	637.17
1A	18+93.00	0	637.42	637.48
1B	19+03.00	0	637.67	637.77
1C	19+13.00	0	637.93	638.06
1D	19+23.00	0	638.18	638.33
1E	19+33.00	0	638.43	638.58
1F	19+43.00	0	638.68	638.82
1G	19+53.00	0	638.93	639.04
1H	19+63.00	0	639.17	639.24
1I	19+73.00	0	639.37	639.41
1J	19+83.00	0	639.52	639.54
1K	19+93.00	0	639.64	639.64
☉ Brg. Pier	20+00.00	0	639.69	639.69
2A	20+10.00	0	639.74	639.76
2B	20+20.00	0	639.74	639.79
2C	20+30.00	0	639.70	639.80
2D	20+40.00	0	639.62	639.77
2E	20+50.00	0	639.51	639.70
2F	20+60.00	0	639.39	639.61
2G	20+70.00	0	639.27	639.51
2H	20+80.00	0	639.15	639.39
2I	20+90.00	0	639.03	639.24
2J	21+00.00	0	638.91	639.08
2K	21+10.00	0	638.79	638.89
☉ Brg. N. Abut.	21+24.00	0	638.62	638.62
Bk. N. Abut.	21+25.83	0	638.60	638.60

**GIRDER 5**

Location	Station	Offset	Theoretical Grade Elevations	Theoretical Grade Elevations Adjusted For Dead Load Deflection
Bk. S. Abut.	18+81.17	8.25	637.00	637.00
☉ Brg. S. Abut.	18+83.00	8.25	637.05	637.05
1A	18+93.00	8.25	637.30	637.35
1B	19+03.00	8.25	637.55	637.65
1C	19+13.00	8.25	637.80	637.94
1D	19+23.00	8.25	638.05	638.20
1E	19+33.00	8.25	638.30	638.46
1F	19+43.00	8.25	638.56	638.69
1G	19+53.00	8.25	638.81	638.92
1H	19+63.00	8.25	639.04	639.12
1I	19+73.00	8.25	639.24	639.28
1J	19+83.00	8.25	639.40	639.41
1K	19+93.00	8.25	639.51	639.51
☉ Brg. Pier	20+00.00	8.25	639.57	639.57
2A	20+10.00	8.25	639.61	639.63
2B	20+20.00	8.25	639.62	639.67
2C	20+30.00	8.25	639.58	639.68
2D	20+40.00	8.25	639.50	639.65
2E	20+50.00	8.25	639.39	639.58
2F	20+60.00	8.25	639.27	639.49
2G	20+70.00	8.25	639.15	639.39
2H	20+80.00	8.25	639.03	639.26
2I	20+90.00	8.25	638.91	639.12
2J	21+00.00	8.25	638.79	638.95
2K	21+10.00	8.25	638.67	638.77
☉ Brg. N. Abut.	21+24.00	8.25	638.50	638.50
Bk. N. Abut.	21+25.83	8.25	638.48	638.48

**GIRDER 6**

Location	Station	Offset	Theoretical Grade Elevations	Theoretical Grade Elevations Adjusted For Dead Load Deflection
Bk. S. Abut.	18+81.17	16.50	636.88	636.88
☉ Brg. S. Abut.	18+83.00	16.50	636.92	636.92
1A	18+93.00	16.50	637.18	637.23
1B	19+03.00	16.50	637.43	637.53
1C	19+13.00	16.50	637.68	637.81
1D	19+23.00	16.50	637.93	638.08
1E	19+33.00	16.50	638.18	638.33
1F	19+43.00	16.50	638.43	638.57
1G	19+53.00	16.50	638.68	638.79
1H	19+63.00	16.50	638.92	639.00
1I	19+73.00	16.50	639.12	639.16
1J	19+83.00	16.50	639.27	639.29
1K	19+93.00	16.50	639.39	639.39
☉ Brg. Pier	20+00.00	16.50	639.45	639.44
2A	20+10.00	16.50	639.49	639.51
2B	20+20.00	16.50	639.49	639.55
2C	20+30.00	16.50	639.46	639.55
2D	20+40.00	16.50	639.38	639.52
2E	20+50.00	16.50	639.26	639.45
2F	20+60.00	16.50	639.14	639.37
2G	20+70.00	16.50	639.02	639.26
2H	20+80.00	16.50	638.90	639.14
2I	20+90.00	16.50	638.78	638.99
2J	21+00.00	16.50	638.66	638.83
2K	21+10.00	16.50	638.54	638.65
☉ Brg. N. Abut.	21+24.00	16.50	638.37	638.37
Bk. N. Abut.	21+25.83	16.50	638.35	638.35

**NOTES:**

Offset measured from ☉ of Wheeler Ave.



USER NAME =	DESIGNED - MK	REVISED -
	CHECKED - DD	REVISED -
PLOT SCALE =	DRAWN - MK	REVISED -
PLOT DATE =	CHECKED - DD	REVISED -

**STATE OF ILLINOIS  
 DEPARTMENT OF TRANSPORTATION**

**TOP OF SLAB ELEVATIONS III  
 STRUCTURE NO. 099-8324**

SHEET S-6 OF S-31 SHEETS

F.A.I. RTE.	SECTION	COUNTY	TOTAL SHEETS	SHEET NO.
80	FAI 80 21 STRUCTURE 9	WILL	130	63
CONTRACT NO. 62R30				
ILLINOIS		FED. AID PROJECT		

GIRDER 7

Location	Station	Offset	Theoretical Grade Elevations	Theoretical Grade Elevations Adjusted For Dead Load Deflection
Bk. S. Abut.	18+81.17	24.75	636.83	636.83
☐ Brg. S. Abut.	18+83.00	24.75	636.87	636.87
1A	18+93.00	24.75	637.13	637.18
1B	19+03.00	24.75	637.38	637.48
1C	19+13.00	24.75	637.63	637.76
1D	19+23.00	24.75	637.88	638.03
1E	19+33.00	24.75	638.13	638.28
1F	19+43.00	24.75	638.38	638.52
1G	19+53.00	24.75	638.63	638.74
1H	19+63.00	24.75	638.87	638.95
1I	19+73.00	24.75	639.07	639.11
1J	19+83.00	24.75	639.22	639.24
1K	19+93.00	24.75	639.34	639.34
☐ Brg. Pier	20+00.00	24.75	639.40	639.40
2A	20+10.00	24.75	639.44	639.46
2B	20+20.00	24.75	639.44	639.50
2C	20+30.00	24.75	639.41	639.50
2D	20+40.00	24.75	639.33	639.47
2E	20+50.00	24.75	639.21	639.40
2F	20+60.00	24.75	639.09	639.32
2G	20+70.00	24.75	638.97	639.21
2H	20+80.00	24.75	638.85	639.09
2I	20+90.00	24.75	638.73	638.94
2J	21+00.00	24.75	638.61	638.78
2K	21+10.00	24.75	638.49	638.60
☐ Brg. N. Abut.	21+24.00	24.75	638.32	638.32
Bk. N. Abut.	21+25.83	24.75	638.30	638.30

NOTES:

Offset measured from ☐ of Wheeler Ave.

MODEL: Sheet  
FILE NAME: pw://transystems-pw.bentley.com:TRANSSYSORP-PW1-HOSTED/Documents/Projects\_2018/CH401/40118002202-Transystems/CAD/62R30/Sheets/2-Structural/099-8324/0998324-CR-03-007-T05\_IV\_Elev.dgn



USER NAME =	DESIGNED - MK	REVISED -
	CHECKED - DD	REVISED -
PLOT SCALE =	DRAWN - MK	REVISED -
PLOT DATE =	CHECKED - DD	REVISED -

**STATE OF ILLINOIS  
DEPARTMENT OF TRANSPORTATION**

**TOP OF SLAB ELEVATIONS IV  
STRUCTURE NO. 099-8324**

F.A.I. RTE.	SECTION	COUNTY	TOTAL SHEETS	SHEET NO.
80	FAI 80 21 STRUCTURE 9	WILL	130	64
			CONTRACT NO. 62R30	
		ILLINOIS	FED. AID PROJECT	

SHEET S-7 OF S-31 SHEETS



WEST EDGE OF SIDEWALK

Location	Station	Offset	Theoretical Grade Elevations
S. End of S. Appr. Slab	18+52.17	-27.00	636.15
A	18+62.17	-27.00	636.40
B	18+72.17	-27.00	636.65
N. End of S. Appr. Slab	18+82.17	-27.00	636.90

WEST EDGE OF CURB

Location	Station	Offset	Theoretical Grade Elevations
S. End of S. Appr. Slab	18+52.17	-22.00	636.04
A	18+62.17	-22.00	636.29
B	18+72.17	-22.00	636.55
N. End of S. Appr. Slab	18+82.17	-22.00	636.80

WEST EDGE OF PAVEMENT

Location	Station	Offset	Theoretical Grade Elevations
S. End of S. Appr. Slab	18+52.17	-17.00	636.14
A	18+62.17	-17.00	636.39
B	18+72.17	-17.00	636.65
N. End of S. Appr. Slab	18+82.17	-17.00	636.90

☉ WHEELER AVENUE AND PGL

Location	Station	Offset	Theoretical Grade Elevations
S. End of S. Appr. Slab	18+52.17	0	636.40
A	18+62.17	0	636.65
B	18+72.17	0	636.90
N. End of S. Appr. Slab	18+82.17	0	637.15

EAST EDGE OF PAVEMENT

Location	Station	Offset	Theoretical Grade Elevations
S. End of S. Appr. Slab	18+52.17	17.00	636.14
A	18+62.17	17.00	636.39
B	18+72.17	17.00	636.65
N. End of S. Appr. Slab	18+82.17	17.00	636.90

EAST EDGE OF CURB

Location	Station	Offset	Theoretical Grade Elevations
S. End of S. Appr. Slab	18+52.17	22.00	636.04
A	18+62.17	22.00	636.29
B	18+72.17	22.00	636.55
N. End of S. Appr. Slab	18+82.17	22.00	636.80

EAST EDGE OF SIDEWALK

Location	Station	Offset	Theoretical Grade Elevations
S. End of S. Appr. Slab	18+52.17	27.00	636.15
A	18+62.17	27.00	636.40
B	18+72.17	27.00	636.65
N. End of S. Appr. Slab	18+82.17	27.00	636.90

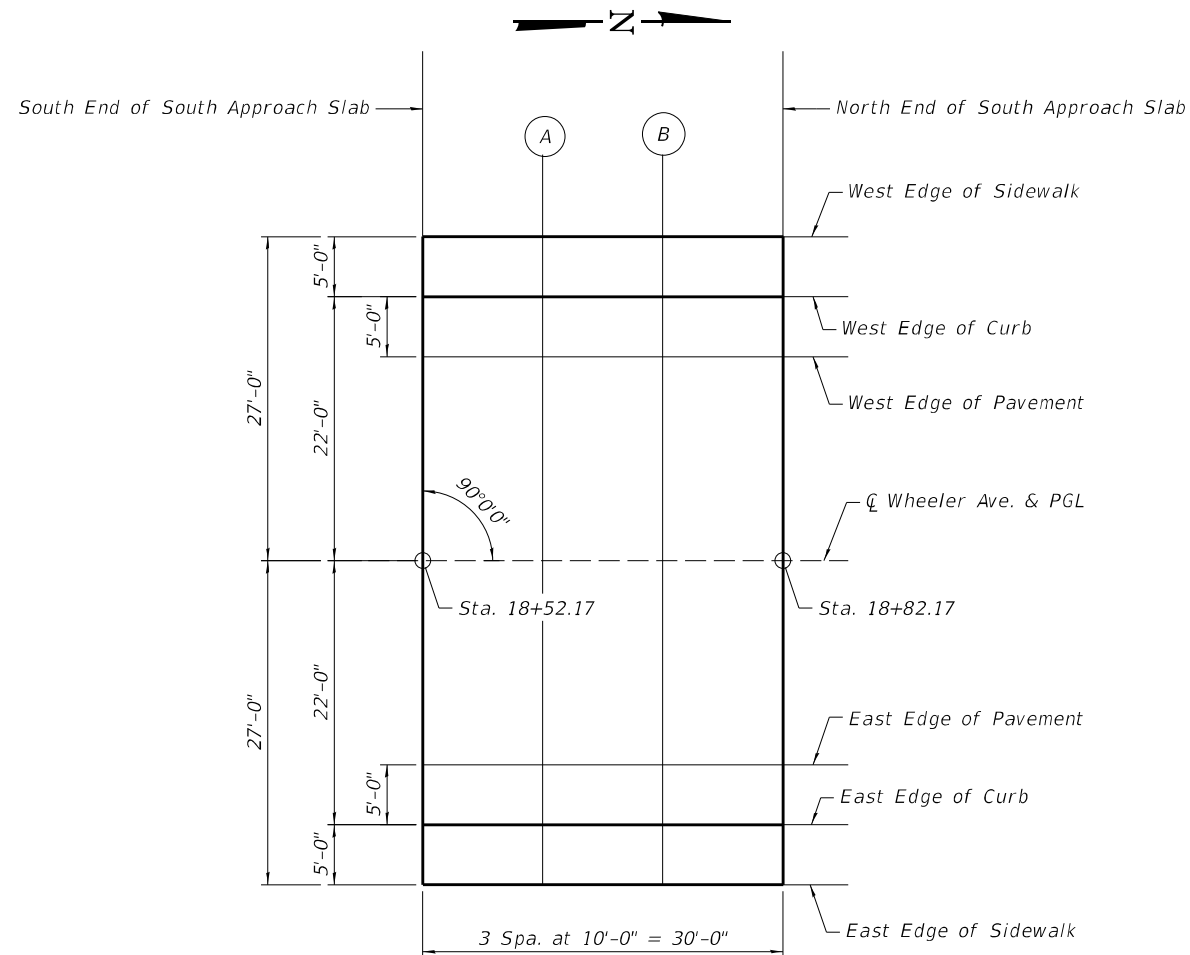

PLAN  
(South Approach)

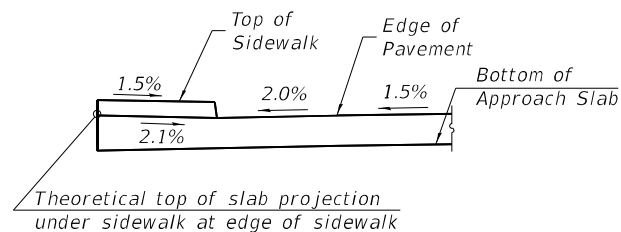

LOCATION OF ELEVATION UNDER WEST SIDEWALK

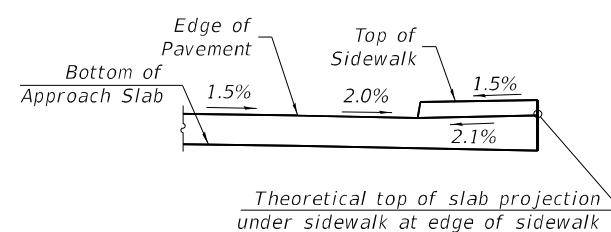

LOCATION OF ELEVATION UNDER EAST SIDEWALK

NOTES:  
Offset measured from ☉ of Wheeler Ave.

MODEL: Sheet  
FILE NAME: pw://transystems-pw.bentley.com:TRANSSYS/Projects\_2018/CH401/401180022/02-TransSystems/CAD/62R30/Sheets/2-Structural/099-8324/0998324-CR-03-008-TOAS\_I\_Elev.dgn



USER NAME =	DESIGNED - MK	REVISED -
PLOT SCALE =	CHECKED - DD	REVISED -
PLOT DATE =	DRAWN - MK	REVISED -
	CHECKED - DD	REVISED -

STATE OF ILLINOIS  
DEPARTMENT OF TRANSPORTATION

TOP OF SOUTH APPROACH SLAB ELEVATIONS  
STRUCTURE NO. 099-8324

SHEET S-8 OF S-31 SHEETS

F.A.I. RTE.	SECTION	COUNTY	TOTAL SHEETS	SHEET NO.
80	FAI 80 21 STRUCTURE 9	WILL	130	65

CONTRACT NO. 62R30

ILLINOIS FED. AID PROJECT

WEST EDGE OF SIDEWALK

Location	Station	Offset	Theoretical Grade Elevations
S. End of N. Appr. Slab	21+24.83	-27.00	638.36
C	21+34.83	-27.00	638.24
D	21+39.83	-27.00	638.19

WEST EDGE OF CURB

Location	Station	Offset	Theoretical Grade Elevations
S. End of N. Appr. Slab	21+24.83	-22.00	638.26
C	21+34.83	-22.00	638.14
D	21+39.83	-22.00	638.08
N. End of N. Appr. Slab	21+44.83	-22.00	638.03

WEST EDGE OF PAVEMENT

Location	Station	Offset	Theoretical Grade Elevations
S. End of N. Appr. Slab	21+24.83	-17.00	638.36
C	21+34.83	-17.00	638.24
D	21+39.83	-17.00	638.18
N. End of N. Appr. Slab	21+44.83	-17.00	638.13

☉ WHEELER AVENUE AND PGL

Location	Station	Offset	Theoretical Grade Elevations
S. End of N. Appr. Slab	21+24.83	0	638.61
C	21+34.83	0	638.49
D	21+39.83	0	638.44
N. End of N. Appr. Slab	21+44.83	0	637.38

EAST EDGE OF PAVEMENT

Location	Station	Offset	Theoretical Grade Elevations
S. End of N. Appr. Slab	21+24.83	17.00	638.36
C	21+34.83	17.00	638.24
D	21+39.83	17.00	638.18
N. End of N. Appr. Slab	21+44.83	17.00	638.13

EAST EDGE OF CURB

Location	Station	Offset	Theoretical Grade Elevations
S. End of N. Appr. Slab	21+24.83	22.00	638.26
C	21+34.83	22.00	638.14
D	21+39.83	22.00	638.08
N. End of N. Appr. Slab	21+44.83	22.00	638.03

EAST EDGE OF SIDEWALK

Location	Station	Offset	Theoretical Grade Elevations
S. End of N. Appr. Slab	21+24.83	27.00	638.36
C	21+34.83	27.00	638.24
D	21+39.83	27.00	638.19

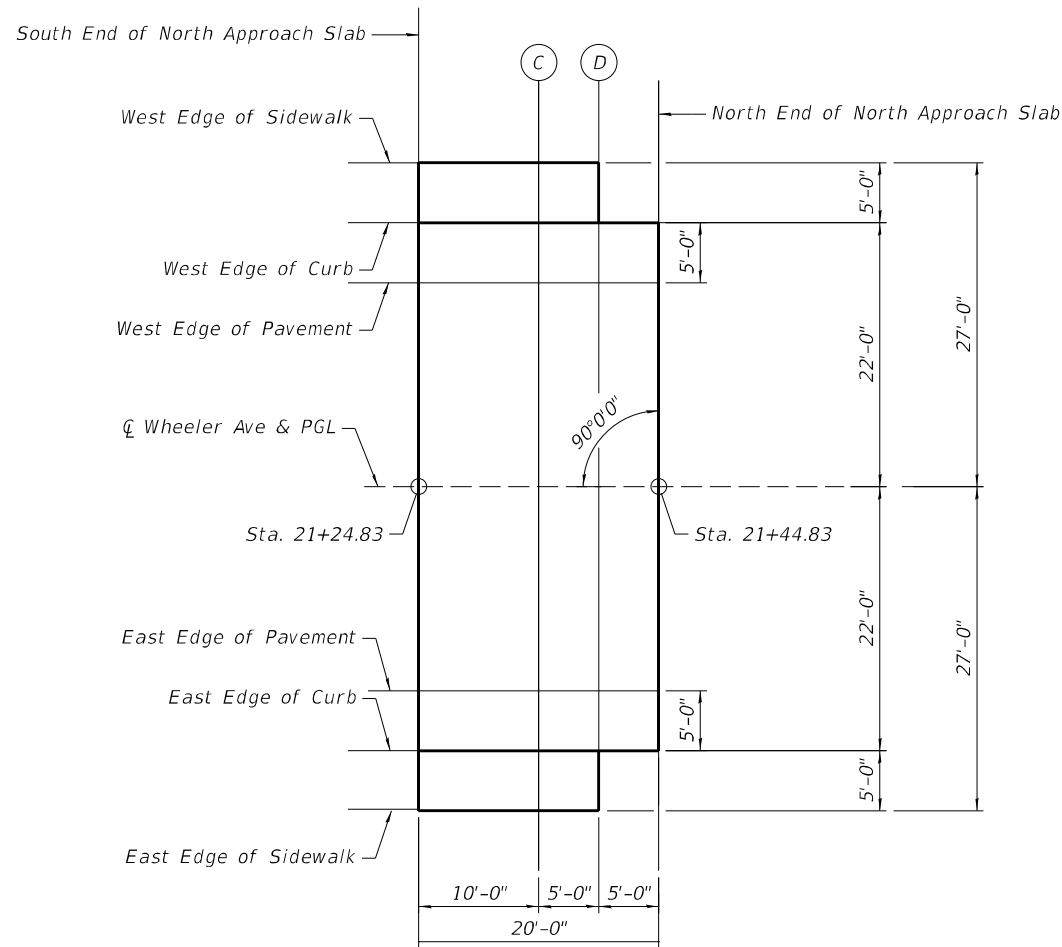
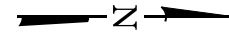

PLAN

(North Approach)

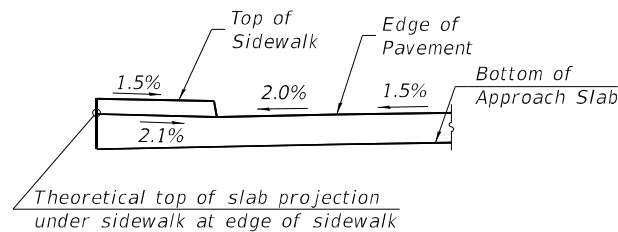

LOCATION OF ELEVATION UNDER WEST SIDEWALK

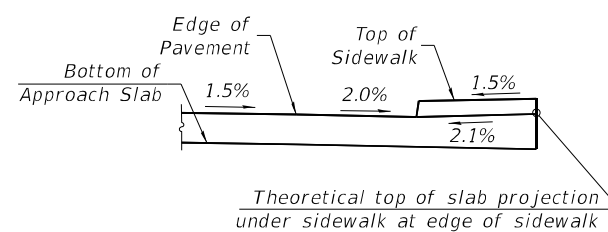

LOCATION OF ELEVATION UNDER EAST SIDEWALK

NOTES:

Offset measured from ☉ of Wheeler Ave.

MODEL: Sheet - 20 feet  
FILE NAME: pw://transystems-pw/bentley.com:TRANSSYS/Projects\_2018/CH401/40118002202-Transystems/CAD/62R30/Sheets/2-Structural/099-8324-CR-03-009-TOAS\_II\_Elev.dgn



USER NAME =	DESIGNED - MK	REVISED -
PLOT SCALE =	CHECKED - DD	REVISED -
PLOT DATE =	DRAWN - MK	REVISED -
	CHECKED - DD	REVISED -

STATE OF ILLINOIS  
DEPARTMENT OF TRANSPORTATION

TOP OF NORTH APPROACH SLAB ELEVATIONS  
STRUCTURE NO. 099-8324

SHEET S-9 OF S-31 SHEETS

F.A.I. RTE.	SECTION	COUNTY	TOTAL SHEETS	SHEET NO.
80	FAI 80 21 STRUCTURE 9	WILL	130	66
CONTRACT NO. 62R30				
ILLINOIS FED. AID PROJECT				

MODEL: Sheet  
 FILE NAME: pw://transsystems-pw.bentley.com/TRANSYS/Projects\_2018/CH401/401180022/02-TransSystems/CAD/62R30/Sheets/2-3-Structural/099-8324-CR-03-01-0-Super.dgn

**MINIMUM BAR LAP**  
 #5 bar = 3'-6"  
 #6 bar = 3'-7"

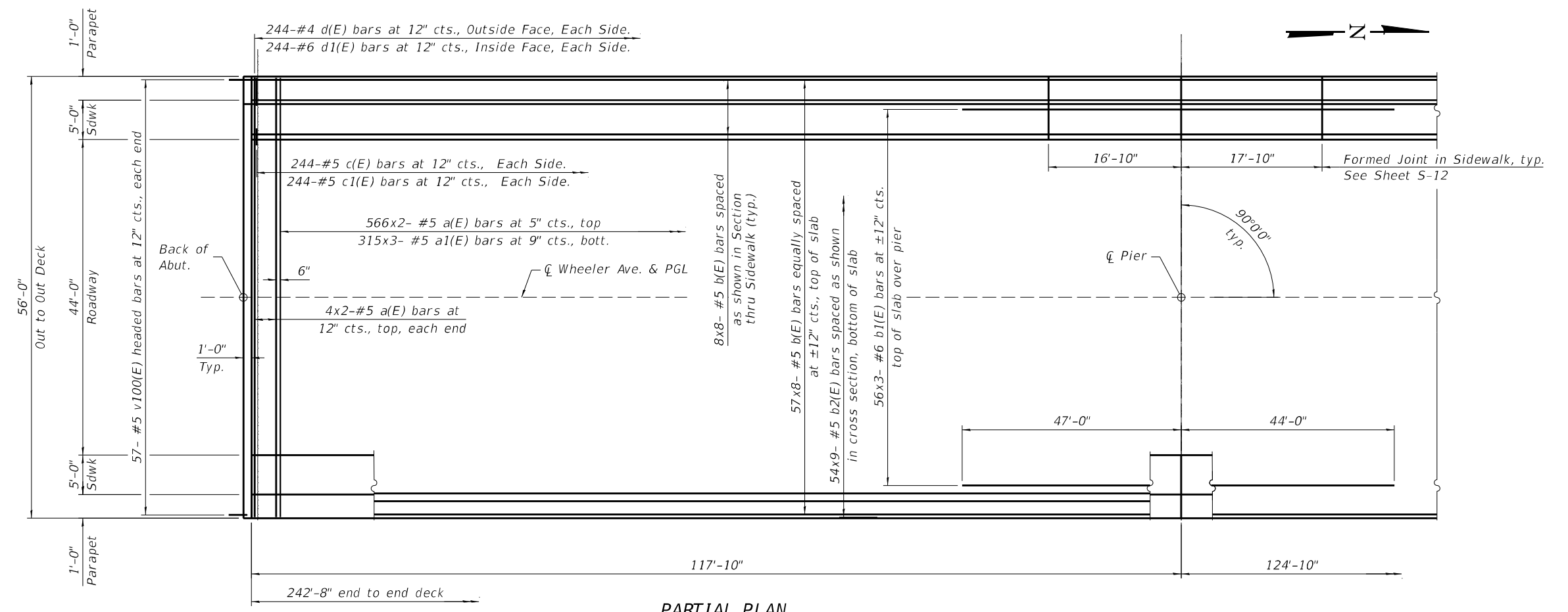

**PARTIAL PLAN**

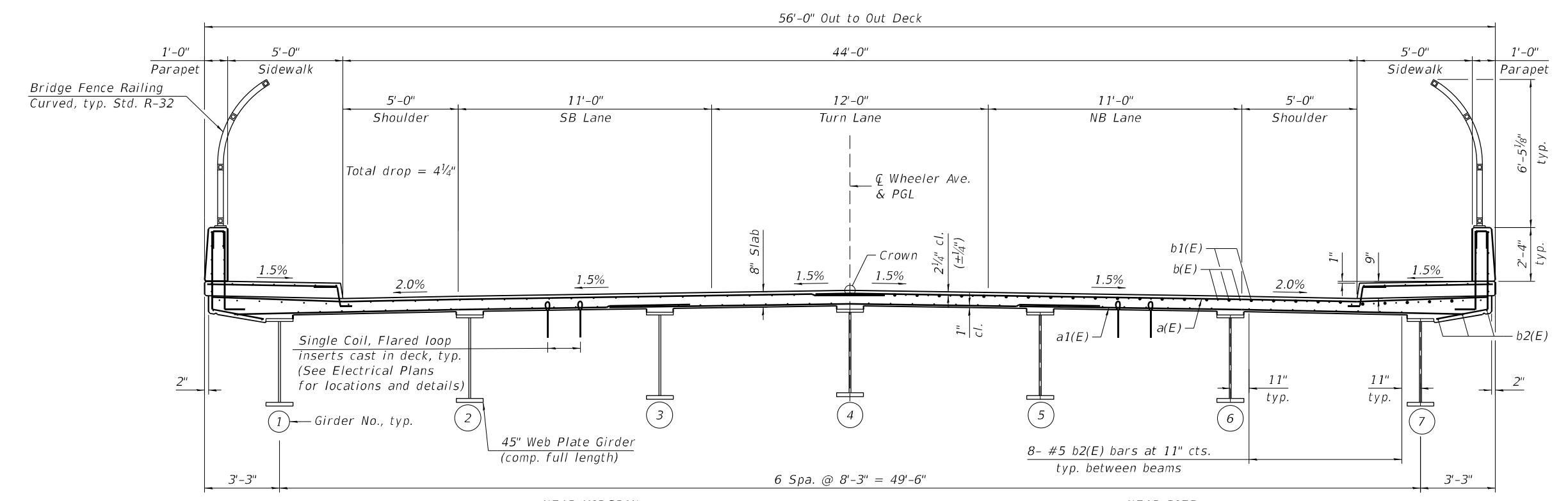

**CROSS SECTION**  
 (Looking North)

- NOTES:**
1. For superstructure details and Bill of Material, see Sheet S-12.
  2. Bars indicated thus 65x3- #6 etc. indicates 65 lines of bars with 3 lengths per line.
  3. For parapet reinforcement, see Sheet S-11.
  4. For Section thru Sidewalk, see Sheet S-12.



USER NAME =	DESIGNED - MK	REVISED -
	CHECKED - DD	REVISED -
PLOT SCALE =	DRAWN - MK	REVISED -
PLOT DATE =	CHECKED - DD	REVISED -

**STATE OF ILLINOIS**  
**DEPARTMENT OF TRANSPORTATION**

**DECK PLAN & CROSS SECTION**  
**STRUCTURE NO. 099-8324**

FAI RTE.	SECTION	COUNTY	TOTAL SHEETS	SHEET NO.
80	FAI 80 21 STRUCTURE 9	WILL	130	67
			CONTRACT NO. 62R30	
ILLINOIS		FED. AID PROJECT		

MODEL: Sheet  
 FILE NAME: pw://transystems-pw.bentley.com/TRANSSYSTEMS/Projects\_2018/CH401/401180022/02-TransSystems/CAD/62R30/Sheets/2-3-Structural/099-8324-CR-03-011-Super\_Detail.dgn  
 9/28/2022 10:59:42 AM

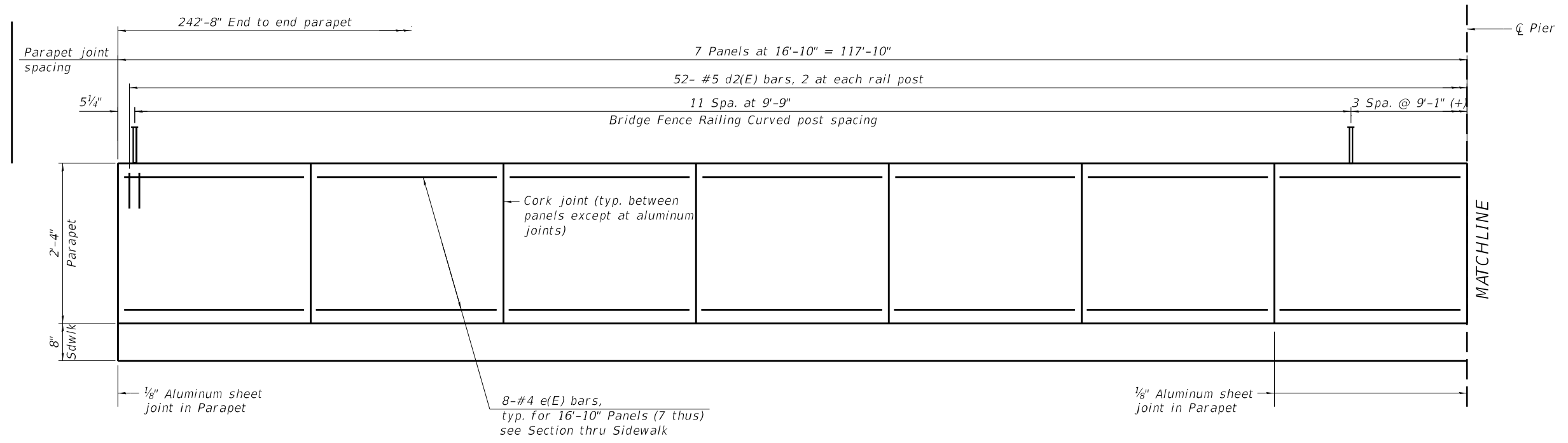

**INSIDE ELEVATION OF PARAPET**  
 (West Parapet shown, East Parapet similar)

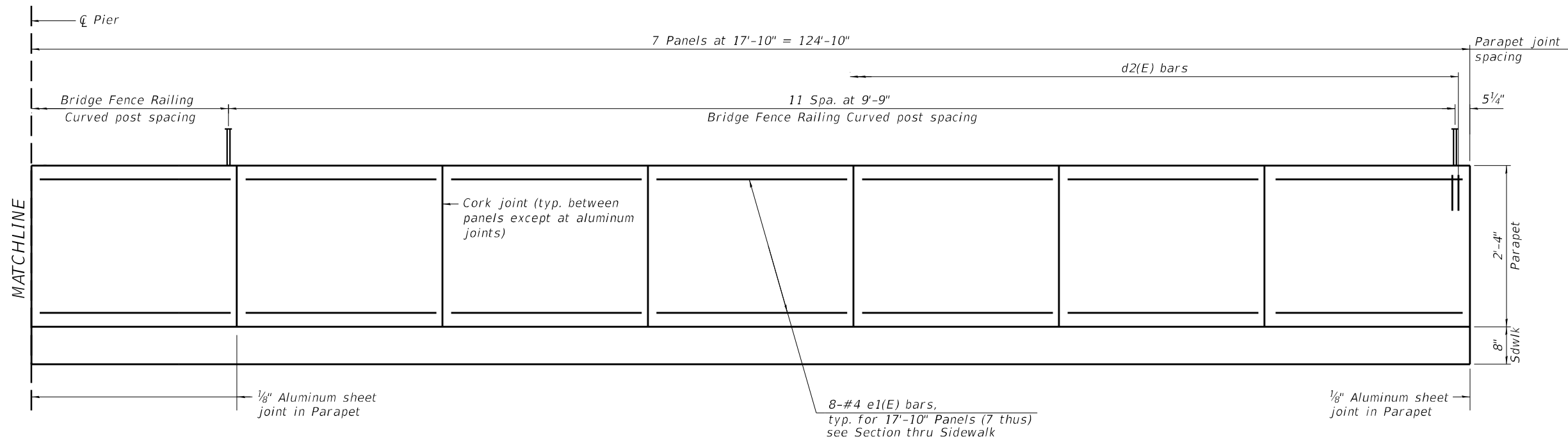

**INSIDE ELEVATION OF PARAPET**  
 (West Parapet shown, East Parapet similar)

**NOTES:**

1. For Superstructure details and Bill of Material, see Sheet S-12.
2. For Railing post details, see Sheet S-18.
3. For Section thru Sidewalk, see Sheet S-12.



USER NAME =	DESIGNED - MK	REVISED -
	CHECKED - DD	REVISED -
PLOT SCALE =	DRAWN - MK	REVISED -
PLOT DATE =	CHECKED - DD	REVISED -

**STATE OF ILLINOIS**  
**DEPARTMENT OF TRANSPORTATION**

**PARAPET ELEVATIONS**  
**STRUCTURE NO. 099-8324**

SHEET S-11 OF S-31 SHEETS

F.A.I. RTE.	SECTION	COUNTY	TOTAL SHEETS	SHEET NO.
80	FAI 80 21 STRUCTURE 9	WILL	130	68
CONTRACT NO. 62R30				
ILLINOIS FED. AID PROJECT				

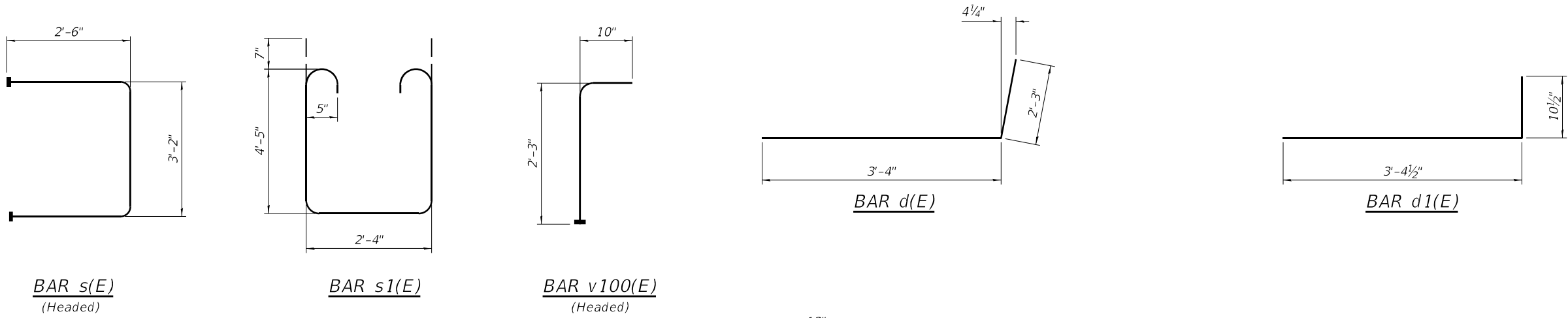

**SUPERSTRUCTURE  
BILL OF MATERIAL**

Bar	No.	Size	Length	Shape
a(E)	1148	#5	29'-7"	—
a1(E)	945	#5	20'-11"	—
b(E)	584	#5	33'-5"	—
b1(E)	168	#6	32'-9"	—
b2(E)	486	#5	30'-1"	—
c(E)	488	#5	2'-4"	—
c1(E)	488	#5	5'-8"	—
d(E)	488	#4	5'-7"	—
d1(E)	488	#6	4'-3"	—
d2(E)	104	#5	2'-0"	—
e(E)	112	#4	16'-6"	—
e1(E)	112	#4	17'-6"	—
m(E)	20	#6	30'-0"	—
m1(E)	48	#6	7'-10"	—
m2(E)	16	#6	2'-10"	—
s(E)	108	#5	8'-2"	—
s1(E)	108	#5	12'-4"	—
v100(E)	114	#5	3'-1"	—
Concrete Superstructure		Cu. Yd.	535.7	
Bridge Deck Grooving		Sq. Yd.	1,133	
Protective Coat		Sq. Yd.	1,664	
Reinforcement Bars, Epoxy Coated		Lbs.	115,890	

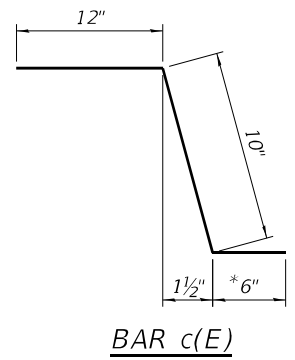

\* In lieu of bottom leg, c(E) bars may be drilled and set according to Article 509.06 of the Standard Specifications. Drilled holes shall be roughened or scored per manufacturer's recommendations. Maximum depth of drilled hole shall not exceed 6". Contractor shall take all necessary precautions to prevent drilled hole interference with deck reinforcement bars. Locate longitudinal bars to miss drilled locations. Locate drilled holes to miss transverse bars in deck.

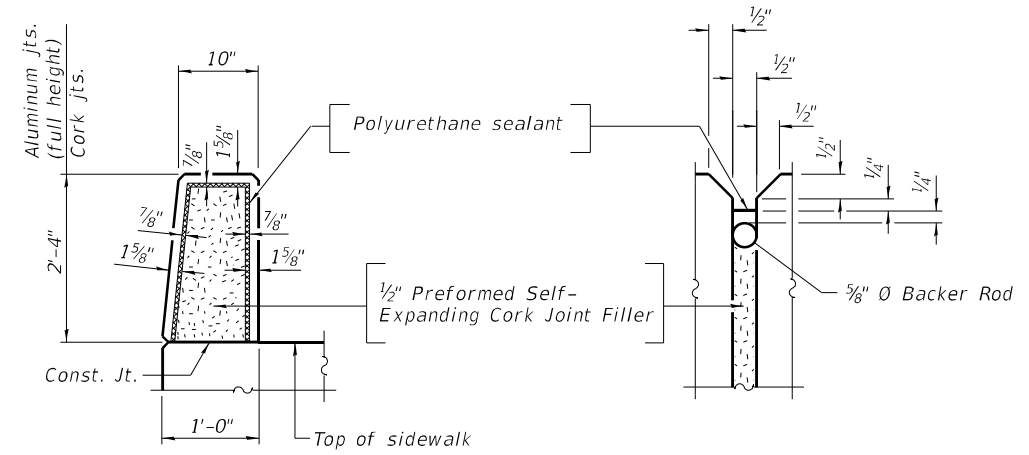
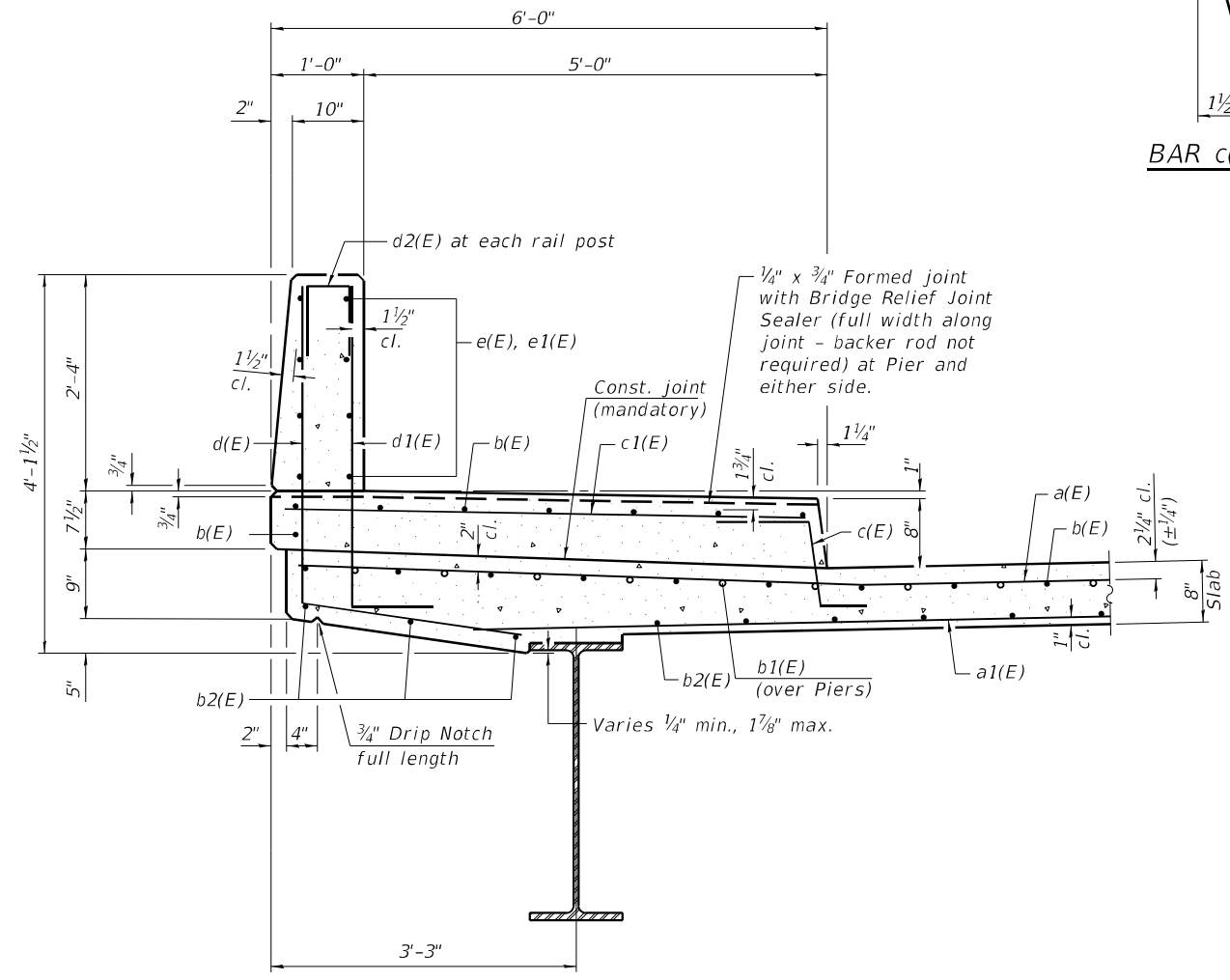
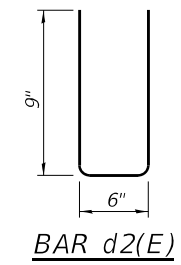

- NOTES:**
1. Headed bars shall conform to ASTM A970 with threaded attachment; Class HA; and reinforcement bars conforming to ASTM A706. Cost included with Reinforcement Bars, Epoxy Coated.
  2. The polyurethane sealant shall be according to Article 1050.04 of the Std. Spec. and the color shall be gray.
  3. The 1/8" aluminum sheet shall be ASTM B 209 alloy 3003-H14 and coated to minimize reaction with wet concrete. Cost included with Concrete Superstructure.

MODEL: Sheet  
FILE NAME: pw://transystems-pw.bentley.com:TRANSYSORP-PW1-HOSTED/Projects\_2018/CH401/40118002202-Transystems/CAD/62R30/Sheets/2-3-Structural/099-8324-CR-03-01-2-Super\_Detail2.dgn



USER NAME =	DESIGNED - MK	REVISED -
PLOT SCALE =	CHECKED - DD	REVISED -
PLOT DATE =	DRAWN - MK	REVISED -
	CHECKED - DD	REVISED -

STATE OF ILLINOIS  
DEPARTMENT OF TRANSPORTATION

SUPERSTRUCTURE DETAILS  
STRUCTURE NO. 099-8324

SHEET S-12 OF S-31 SHEETS

F.A.I. RTE.	SECTION	COUNTY	TOTAL SHEETS	SHEET NO.
80	FAI 80 21 STRUCTURE 9	WILL	130	69
			CONTRACT NO. 62R30	
ILLINOIS		FED. AID PROJECT		

MODEL: Sheet  
 FILE NAME: pw://transsystems-pw.bentley.com:TRANSSYSORP-PW1-HOSTED/Projects\_2018/CH401/40118002202-TransSystems/CAD/62R30/Sheets/2-Structural/099-8324-CR-03-01-3-01aph.dgn

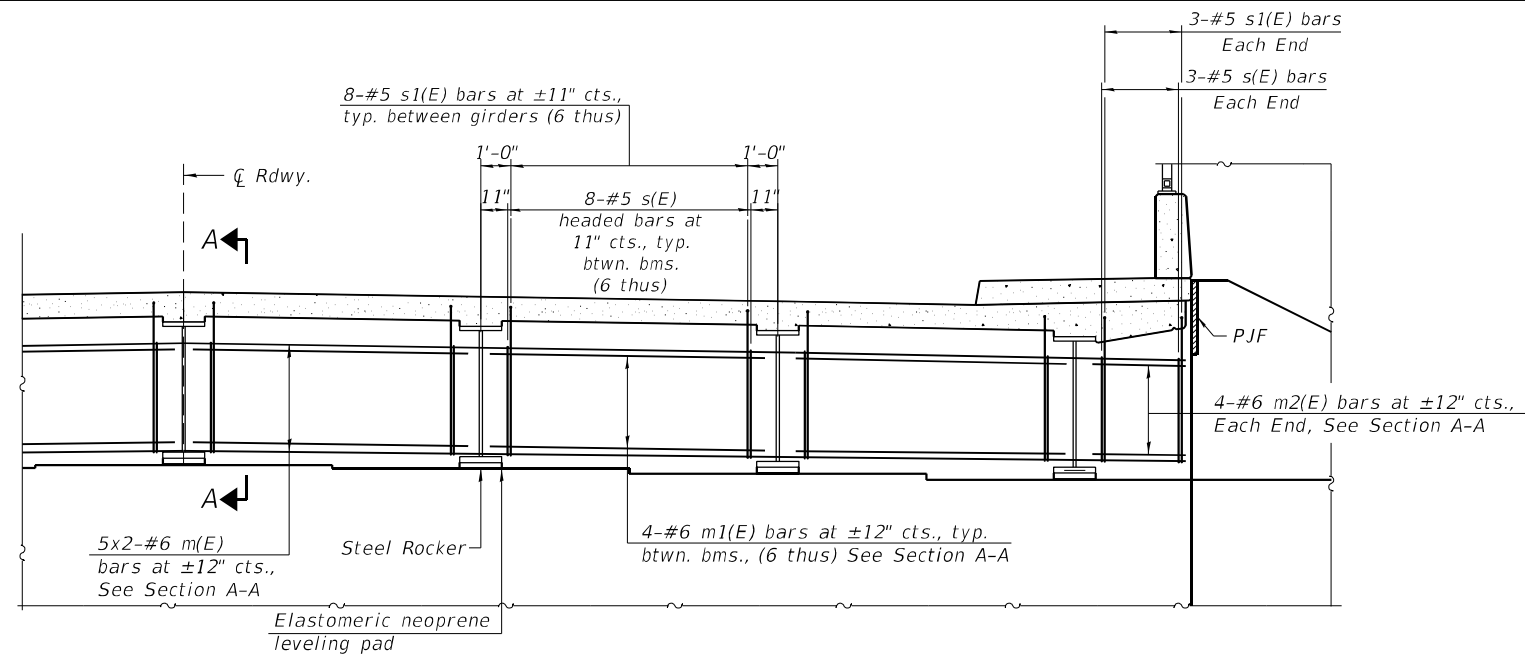

MINIMUM BAR LAP  
 #6 bar = 4'-4"

**DIAPHRAGM AT ABUTMENT**

(partial elevation at North Abutment shown,  
 South Abutment similar)

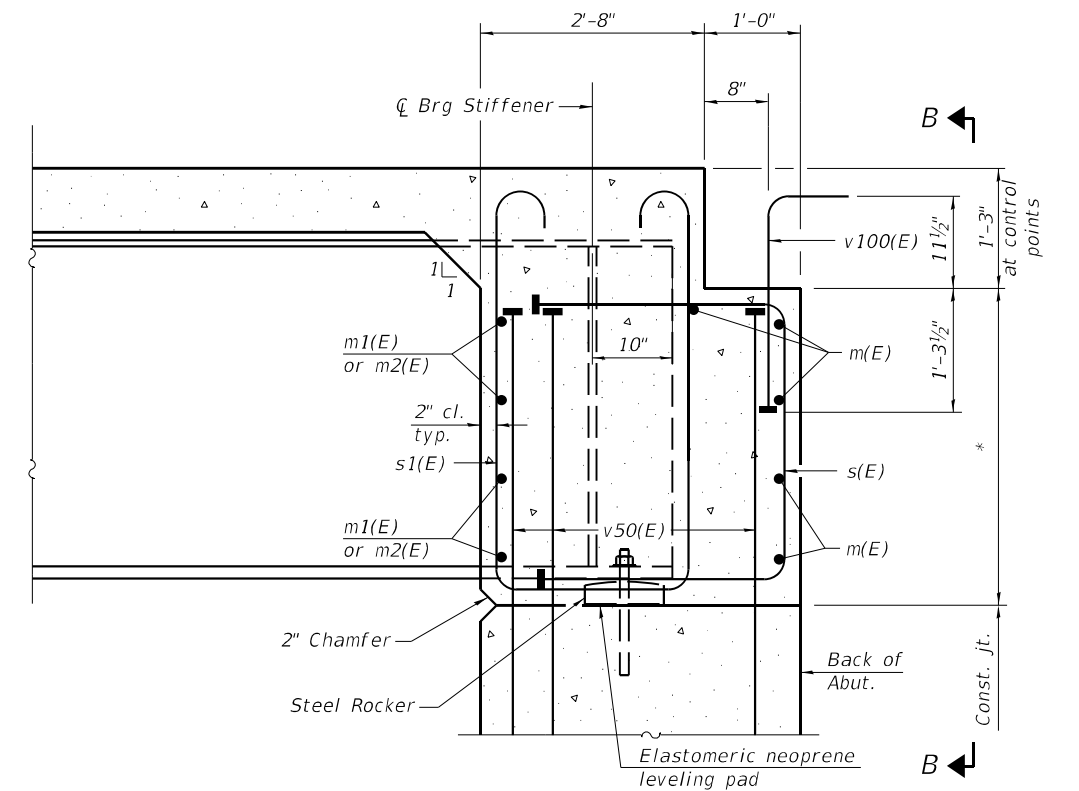

**SECTION A-A**

\* Varies 3'-6 3/8" to 3'-8 1/8" (S. Abut.)  
 Varies 3'-6 1/2" to 3'-8 1/4" (N. Abut.)

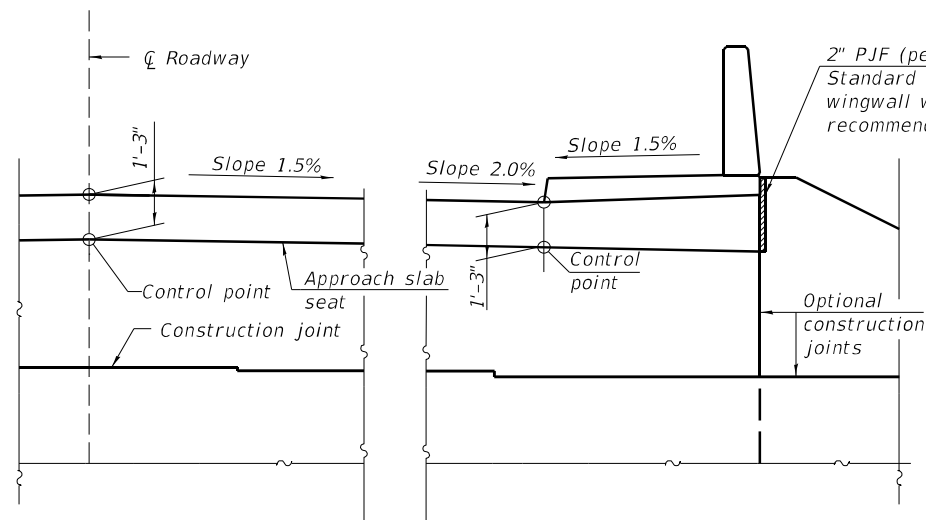

**SECTION B-B**

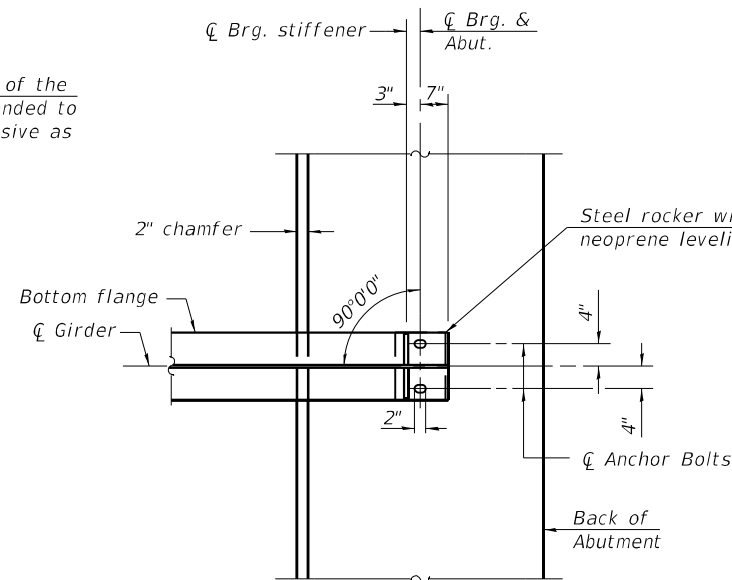

**PLAN AT ABUTMENT**

(Showing bottom flange of girder)

**NOTES:**

1. See sheet S-12 for superstructure details and Bill of Materials.
2. Concrete in diaphragm is included with Concrete Superstructure on Sheet S-12.
3. For details of bars s(E), s1(E), and v100(E) see sheet S-12.
4. For bearing details see sheet S-23.
5. The approach slab seat shall have a constant slope determined from the control points shown.



USER NAME =	DESIGNED - MK	REVISED -
	CHECKED - DD	REVISED -
PLOT SCALE =	DRAWN - MK	REVISED -
PLOT DATE =	CHECKED - DD	REVISED -

STATE OF ILLINOIS  
 DEPARTMENT OF TRANSPORTATION

DIAPHRAGM DETAILS  
 STRUCTURE NO. 099-8324

SHEET S-13 OF S-31 SHEETS

F.A.I. RTE.	SECTION	COUNTY	TOTAL SHEETS	SHEET NO.
80	FAI 80 21 STRUCTURE 9	WILL	130	70
CONTRACT NO. 62R30				

ILLINOIS FED. AID PROJECT

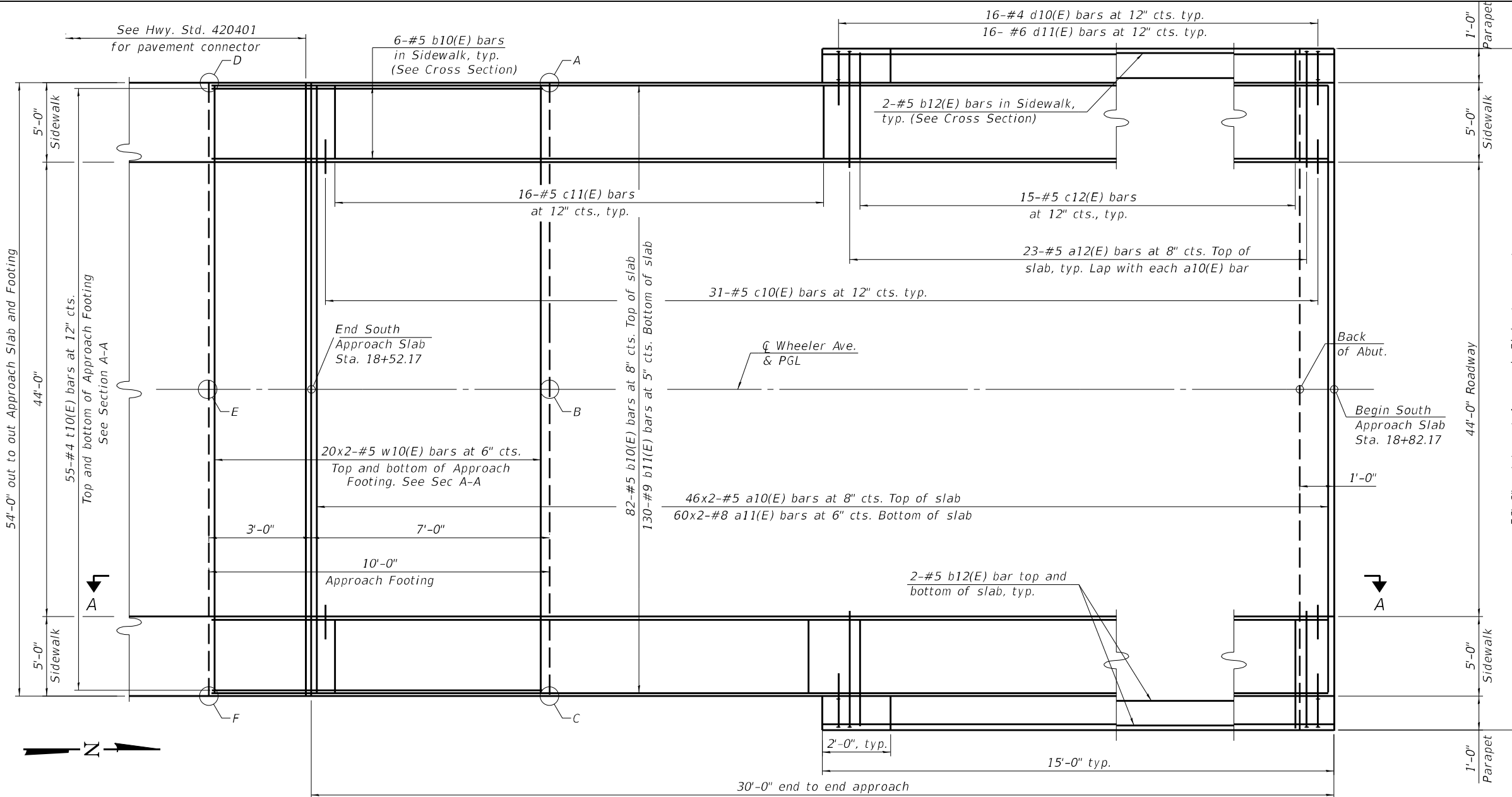

**TOP AND BOTTOM ELEVATIONS FOR APPROACH FOOTING**

Point	South Approach	
	Top	Bottom
A	634.88	634.05
B	635.32	634.49
C	634.88	634.05
D	634.64	633.81
E	635.08	634.24
F	634.64	633.81

**MIN BAR LAP**

#5 bars = 3'-4"  
#8 bars = 4'-9"

**NOTES:**

- See Sheet S-15 for Section A-A, bar details, Bill of Material and sidewalk sliding plate detail.
- See Sheet S-15 and Section B-B for Parapet and Sidewalk under Parapet dimensions and details.

**PLAN**

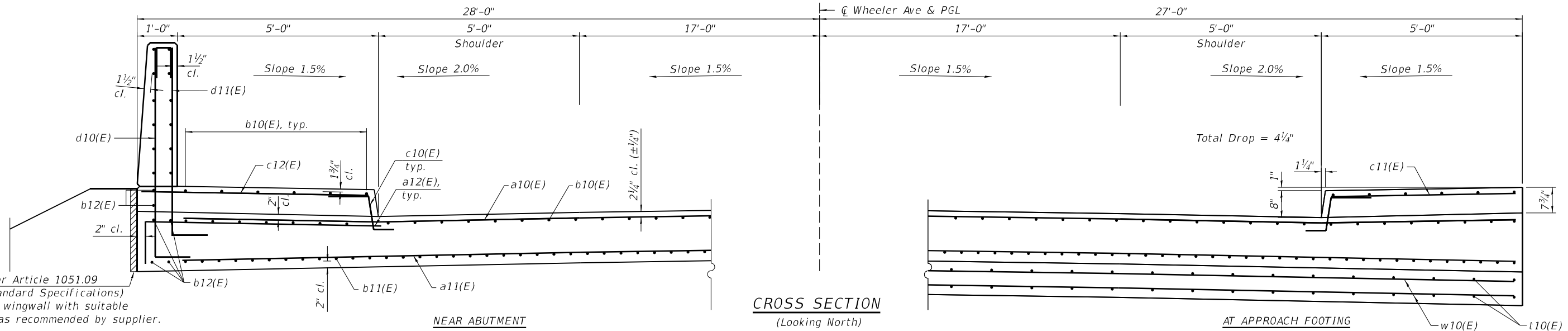

**CROSS SECTION (Looking North)**



USER NAME =  
DESIGNED - MK  
CHECKED - DD  
PLOT SCALE =  
DRAWN - MK  
PLOT DATE =  
CHECKED - DD

DESIGNED - MK  
CHECKED - DD  
DRAWN - MK  
CHECKED - DD  
REVISED -  
REVISED -  
REVISED -  
REVISED -

**STATE OF ILLINOIS  
DEPARTMENT OF TRANSPORTATION**

**SOUTH APPROACH SLAB PLAN  
STRUCTURE NO. 099-8324**

F.A.I. RTE.	SECTION	COUNTY	TOTAL SHEETS	SHEET NO.
80	FAI 80 21 STRUCTURE 9	WILL	130	71
CONTRACT NO. 62R30			ILLINOIS   FED. AID PROJECT	

MODEL: Sheet  
FILE NAME: pw:/transsystems-pw/bentley.com/TRANSVSCORP-PW1-HOSTED/Projects/2018/CH401/401180022/02-TransSystems/CAD/62R30/Sheets/23-Structural/099-8324-CP-03-01-4-Appr\_ldgn  
9/28/2022 11:00:05 AM

MODEL: Sheet  
 FILE NAME: pw://transystems-pw.bentley.com:TRANSSYSORP-PW1-HOSTED/Projects\_2018/CH401/40118002202-Transystems/CAD/62R30/Sheets/2-Structural/099-8324-CR-03-015-Appr\_1.dgn  
 9/28/2022 11:00:12 AM

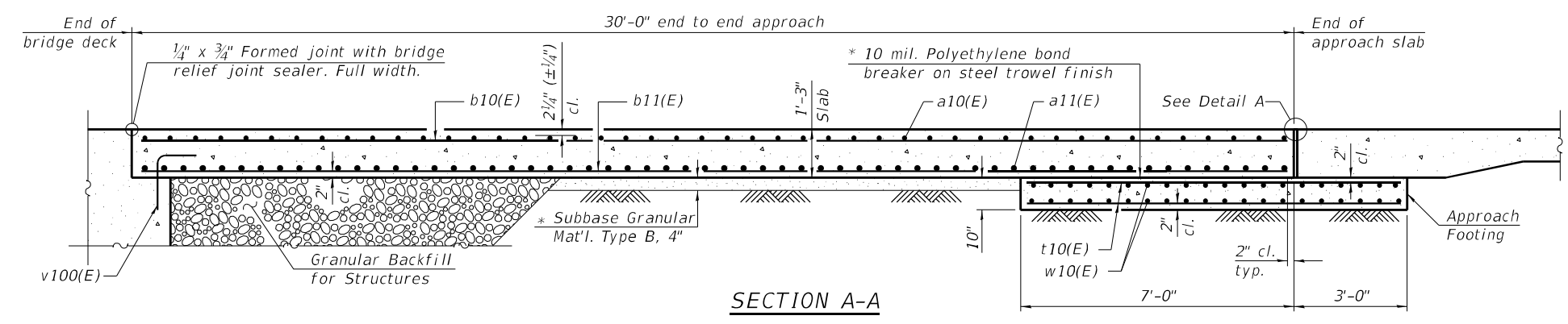

**NOTES:**

- The joint opening shall be adjusted for temperature per Article 520.04 of the Standard Specifications. However, since this detail is for jointless structures, the length of bridge used to calculate the adjustment shall be equal to half the total bridge length plus the length of the bridge approach slab.
- Parapet concrete shall be paid for as Concrete Superstructure.
- Approach slab shall be paid for as Concrete Superstructure (Approach Slab).
- Approach footing concrete shall be paid for as Concrete Structures.
- The approach footing maximum applied service bearing pressure ( $Q_{max}$ ) = 2.0 ksf.
- Cost of excavation for approach footing included with Concrete Structures.
- For Granular Backfill for Structures and drainage treatment details, see Sheet S-2.

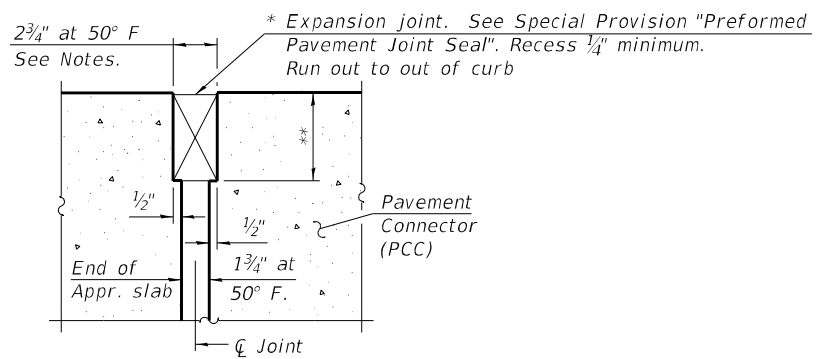
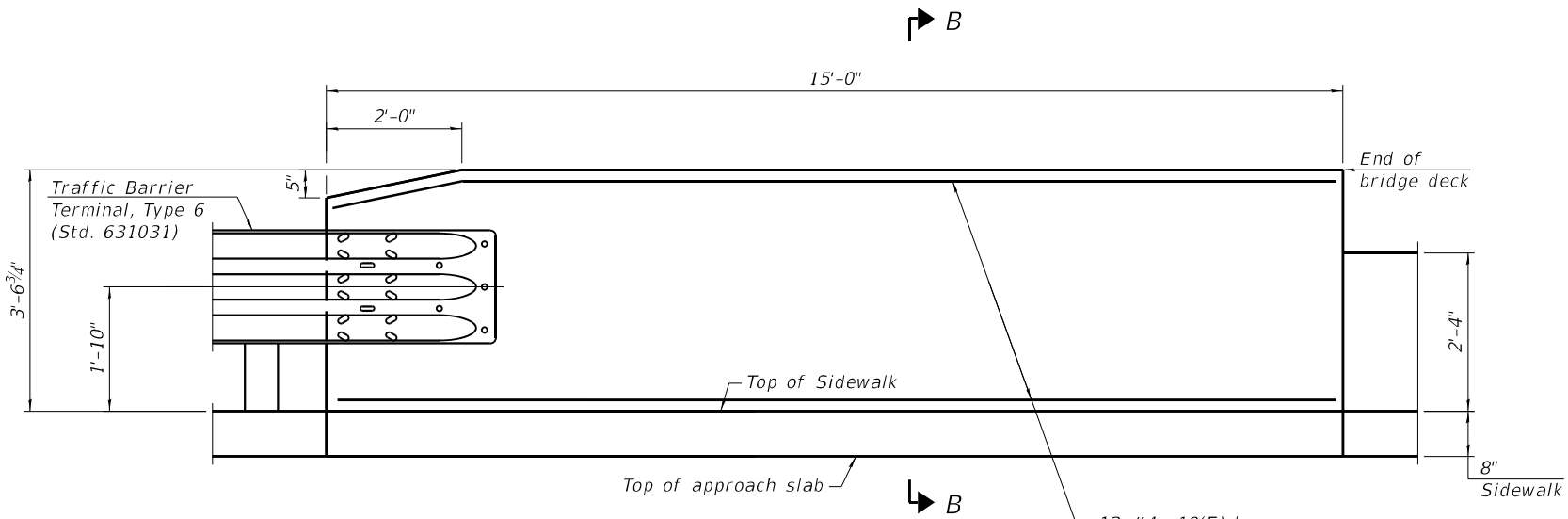

**DETAIL A**

\* Cost included with Concrete Superstructure (Approach Slab).  
 \*\* Per manufacturer recommendations

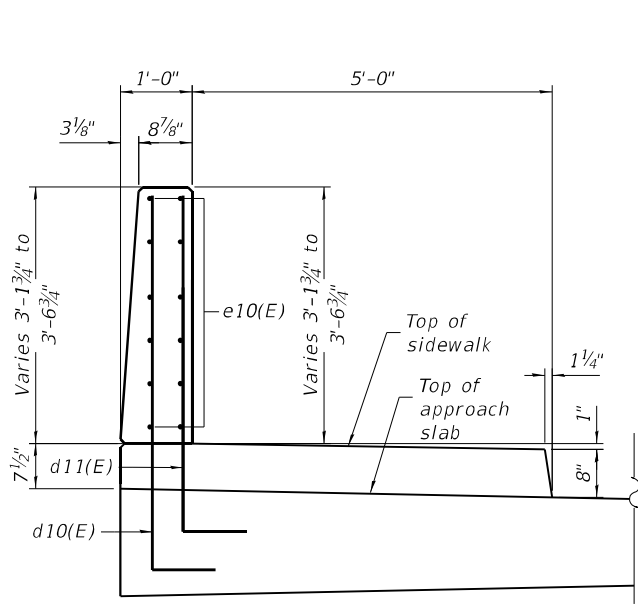

**SECTION B-B**

\*\*\* In lieu of bottom leg, c10(E) bars may be drilled and set according to Article 509.06 of the Standard Specifications. Drilled holes shall be roughened or scored per manufacturer's recommendations. Maximum depth of drilled hole shall not exceed 6". Contractor shall take all necessary precautions to prevent drilled hole interference with deck reinforcement bars. Locate longitudinal bars to miss drilled locations. Locate drilled holes to miss transverse bars in deck.

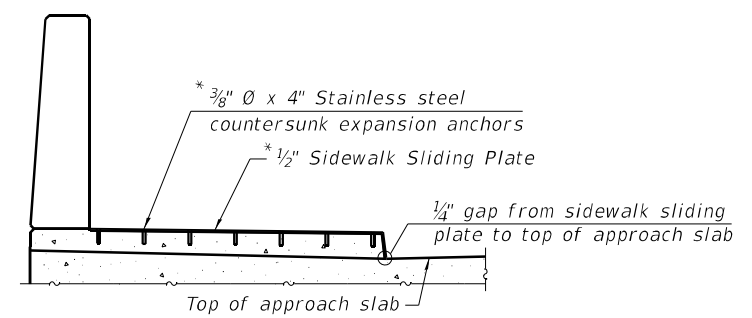
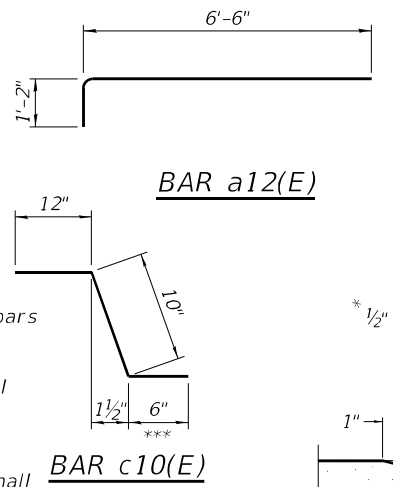

**SECTION AT APPROACH SLAB SIDEWALK**

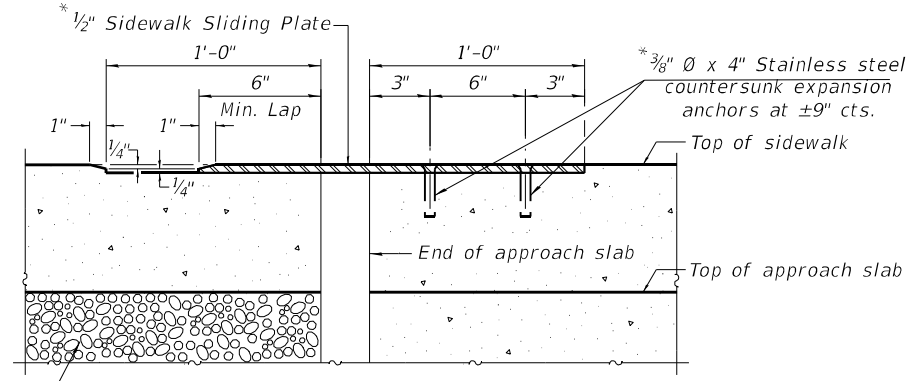

**APPROACH SLAB SIDEWALK SLIDING PLATE DETAIL**

**SOUTH APPROACH BILL OF MATERIAL**

Bar	No.	Size	Length	Shape
a10(E)	92	#5	28'-6"	—
a11(E)	120	#8	29'-3"	—
a12(E)	46	#5	7'-8"	┌
b10(E)	94	#5	29'-8"	—
b11(E)	130	#9	29'-8"	—
b12(E)	12	#5	14'-8"	—
c10(E)	62	#5	2'-4"	┌
c11(E)	32	#5	4'-8"	—
c12(E)	30	#5	5'-8"	—
d10(E)	32	#4	6'-0"	┌
d11(E)	32	#6	5'-7"	┌
e10(E)	24	#4	14'-8"	—
t10(E)	110	#4	9'-8"	—
w10(E)	80	#5	28'-6"	—
Concrete Superstructure			Cu. Yd.	11.4
Concrete Superstructure (Approach Slab)			Cu. Yd.	78.0
Concrete Structures			Cu. Yd.	16.7
Bridge Deck Grooving			Sq. Yd.	140
Protective Coat			Sq. Yd.	199
Reinforcement Bars, Epoxy Coated			Pound	32,890



USER NAME =	DESIGNED - MK	REVISED -
PLOT SCALE =	CHECKED - DD	REVISED -
PLOT DATE =	DRAWN - MK	REVISED -
	CHECKED - DD	REVISED -

**STATE OF ILLINOIS  
DEPARTMENT OF TRANSPORTATION**

**SOUTH APPROACH SLAB DETAILS  
STRUCTURE NO. 099-8324**

SHEET S-15 OF S-31 SHEETS

F.A.I. RTE.	SECTION	COUNTY	TOTAL SHEETS	SHEET NO.
80	FAI 80 21 STRUCTURE 9	WILL	130	72
CONTRACT NO. 62R30				
ILLINOIS FED. AID PROJECT				



MODEL: Sheet - 20  
 FILE NAME: pw://transsystems-pw.bentley.com:TRANSYS-CORP-PW1-HOSTED/Projects/2018/CH401/40118002202-TransSystems/CAD/62R30/Sheets/2-Structural/099-8324-CR-03-016-Appr\_ILI.dgn

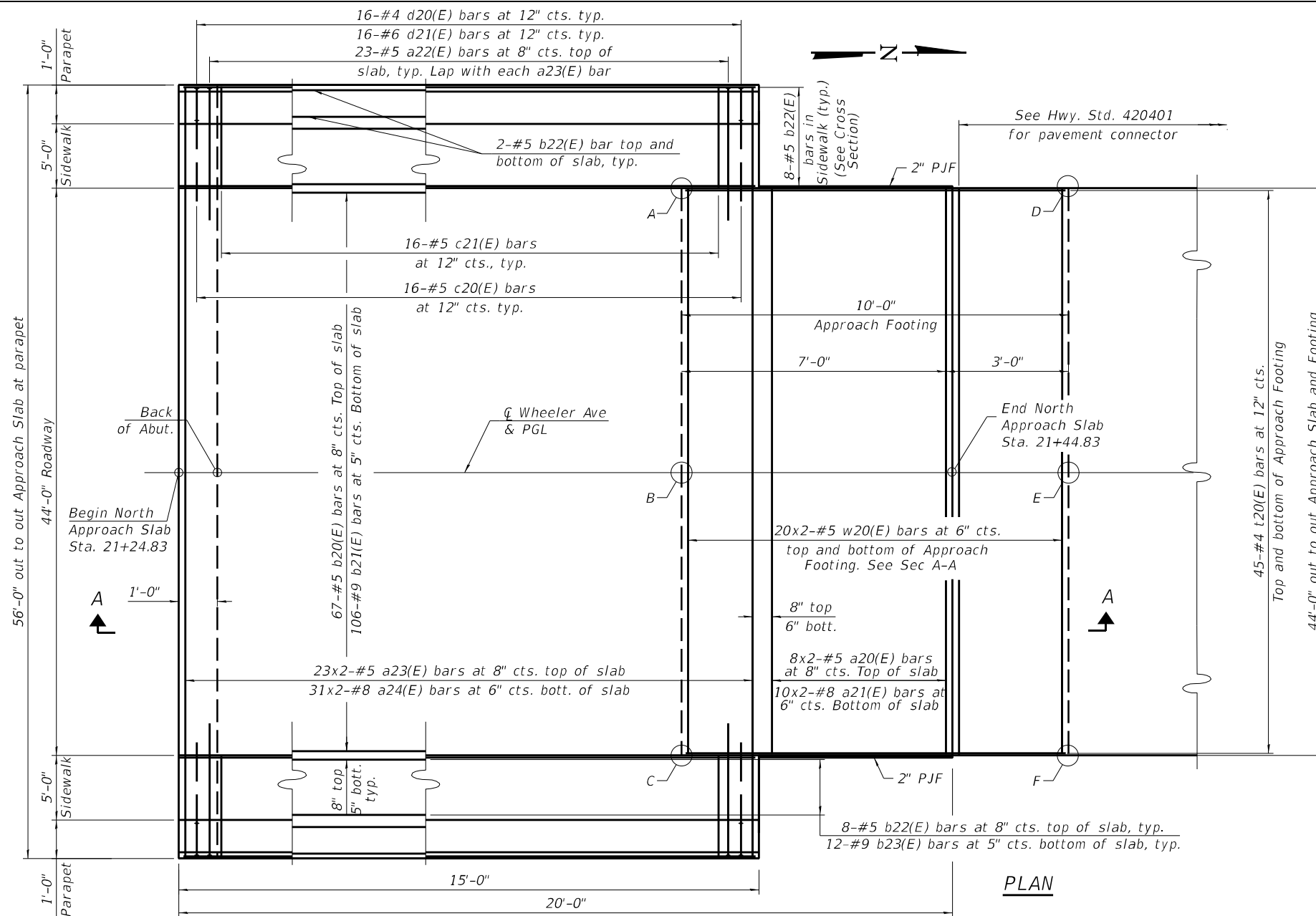

PLAN

TOP AND BOTTOM ELEVATIONS  
 FOR APPROACH FOOTING

Point	North Approach	
	Top	Bottom
A	636.85	636.02
B	637.21	636.38
C	636.85	636.02
D	636.75	635.91
E	637.10	636.27
F	636.75	635.91

MIN BAR LAP

#5 bars = 3'-4"  
 #8 bars = 4'-9"

NOTES:

- See Sheet S-17 for Section A-A, bar details and Bill of Material.
- See Sheet S-17 and Section B-B for Parapet and Sidewalk under Parapet dimensions and details.

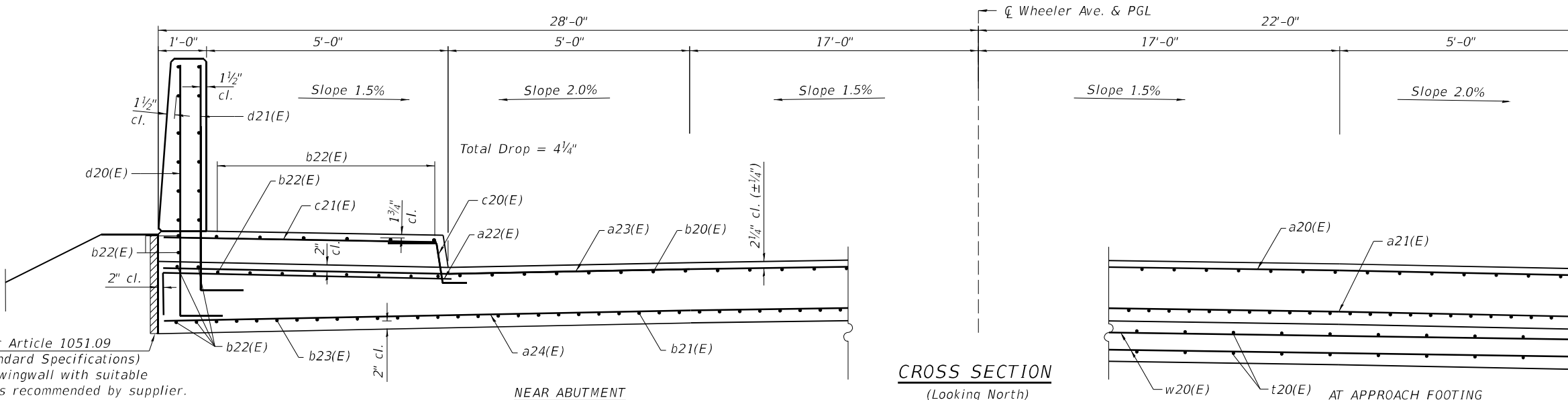

CROSS SECTION  
 (Looking North)

2" P.J.F. (per Article 1051.09 of the Standard Specifications) bonded to wingwall with suitable adhesive as recommended by supplier.



USER NAME =	DESIGNED - MK	REVISED -
PLOT SCALE =	CHECKED - DD	REVISED -
PLOT DATE =	DRAWN - MK	REVISED -
	CHECKED - DD	REVISED -

STATE OF ILLINOIS  
 DEPARTMENT OF TRANSPORTATION

NORTH APPROACH SLAB PLAN  
 STRUCTURE NO. 099-8324

SHEET S-16 OF S-31 SHEETS

F.A.I. RTE.	SECTION	COUNTY	TOTAL SHEETS	SHEET NO.
80	FAI 80 21 STRUCTURE 9	WILL	130	73
CONTRACT NO. 62R30				

ILLINOIS FED. AID PROJECT

MODEL: Sheet - 20 feet  
 FILE NAME: pw://transsystems-pw.bentley.com:TRANSYSORP-PW1-HOSTED/Projects\_2018/CH401/40118002202-TransSystems/CAD/62R30/Sheets/2-Structural/099-8324/0998324-CR-03-017-Appr\_IV.dgn  
 9/28/2022 11:00:27 AM

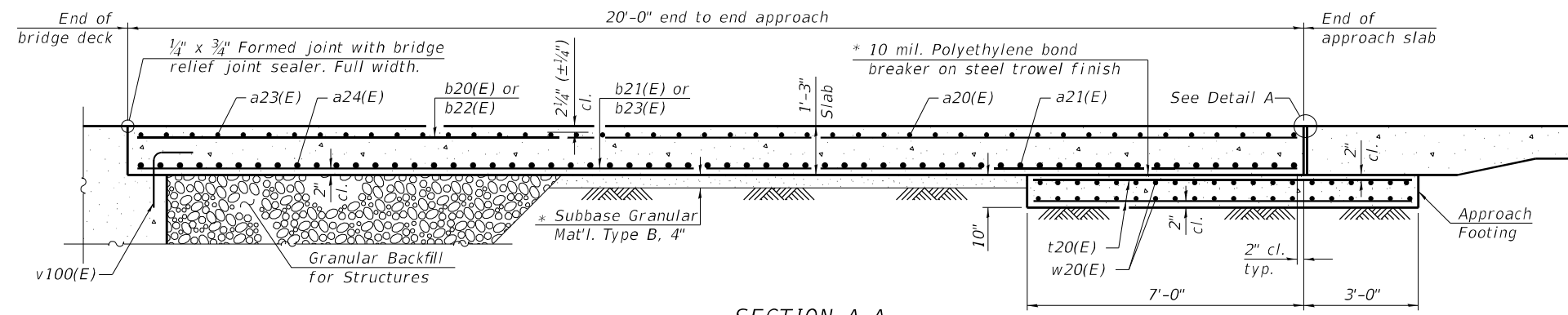

**SECTION A-A**

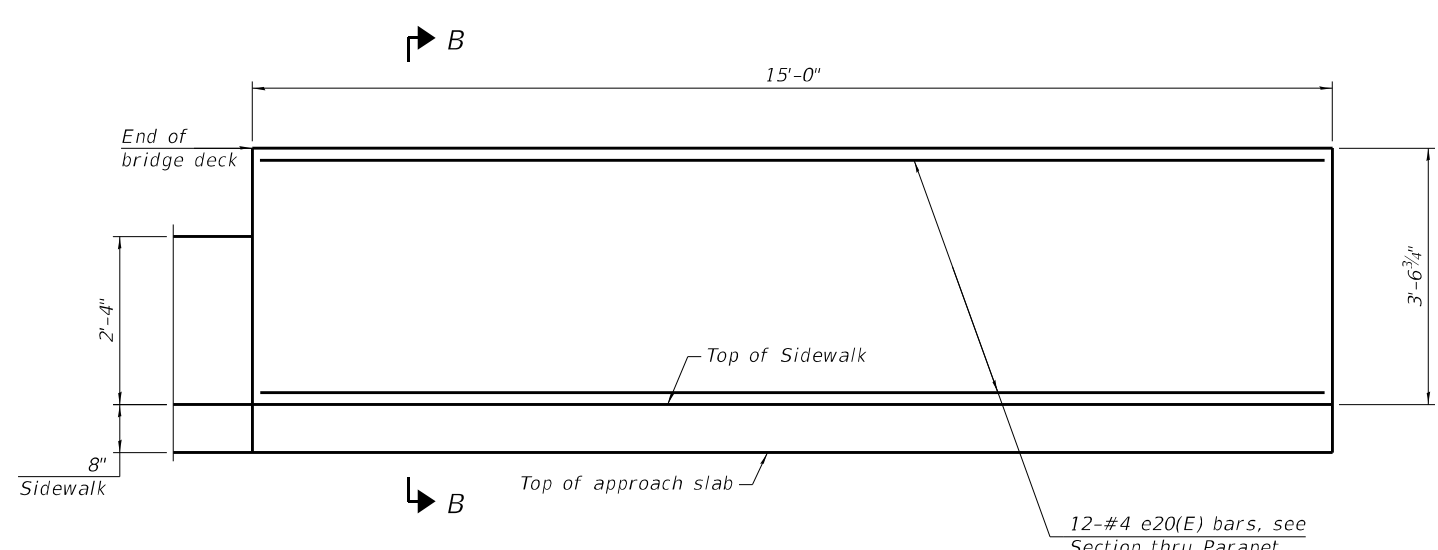

**INSIDE ELEVATION OF PARAPET**

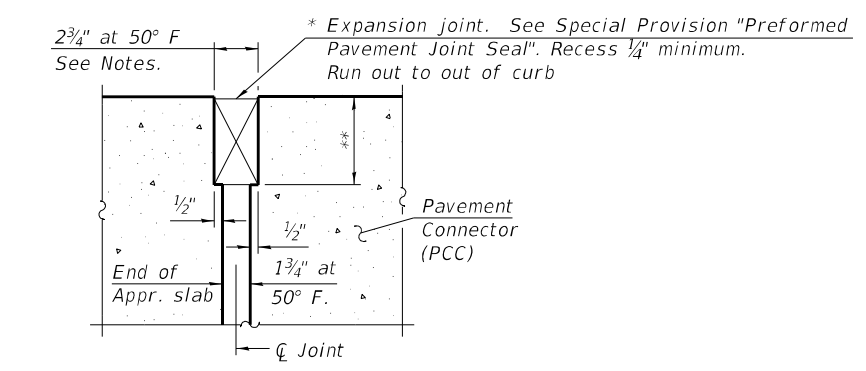

**DETAIL A**

\* Cost included with Concrete Superstructure (Approach Slab).  
 \*\* Per manufacturer recommendations

**NORTH APPROACH  
BILL OF MATERIAL**

Bar	No.	Size	Length	Shape
a20(E)	16	#5	23'-6"	—
a21(E)	20	#8	24'-3"	—
a22(E)	46	#5	7'-8"	—
a23(E)	46	#5	29'-6"	—
a24(E)	62	#8	30'-3"	—
b20(E)	67	#5	19'-8"	—
b21(E)	106	#9	19'-8"	—
b22(E)	40	#5	14'-8"	—
b23(E)	24	#9	14'-8"	—
c20(E)	32	#5	2'-4"	⌒
c21(E)	32	#5	5'-8"	—
d20(E)	32	#4	6'-0"	⌒
d21(E)	32	#6	5'-7"	⌒
e20(E)	24	#4	14'-8"	—
t20(E)	90	#4	9'-8"	—
w20(E)	80	#5	23'-6"	—
Concrete Superstructure				Cu. Yd. 7.8
Concrete Superstructure (Approach Slab)				Cu. Yd. 70.3
Concrete Structures				Cu. Yd. 13.6
Bridge Deck Grooving				Sq. Yd. 94
Protective Coat				Sq. Yd. 132
Reinforcement Bars, Epoxy Coated				Pound 22,190

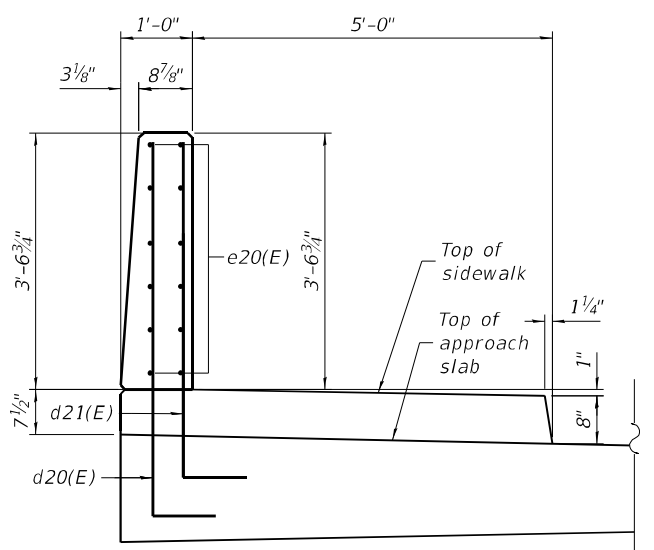

**SECTION B-B**

\*\*\* In lieu of bottom leg, c20(E) bars may be drilled and set according to Article 509.06 of the Standard Specifications. Drilled holes shall be roughened or scored per manufacturer's recommendations. Maximum depth of drilled hole shall not exceed 6". Contractor shall take all necessary precautions to prevent drilled hole interference with deck reinforcement bars. Locate longitudinal bars to miss drilled locations. Locate drilled holes to miss transverse bars in deck.

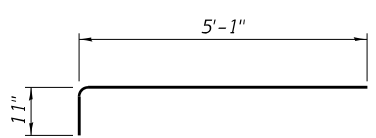

**BAR d20(E)**

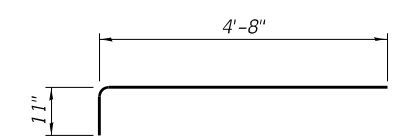

**BAR d21(E)**

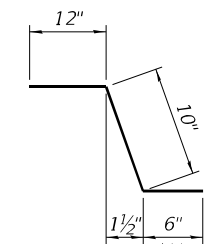

**BAR c20(E)**

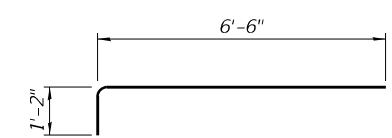

**BAR a22(E)**



USER NAME =	DESIGNED - MK	REVISED -
PLOT SCALE =	CHECKED - DD	REVISED -
PLOT DATE =	DRAWN - MK	REVISED -
	CHECKED - DD	REVISED -

**STATE OF ILLINOIS  
DEPARTMENT OF TRANSPORTATION**

**NORTH APPROACH SLAB DETAILS  
STRUCTURE NO. 099-8324**

SHEET S-17 OF S-31 SHEETS

F.A.I. RTE.	SECTION	COUNTY	TOTAL SHEETS	SHEET NO.
80	FAI 80 21 STRUCTURE 9	WILL	130	74
CONTRACT NO. 62R30				

ILLINOIS FED. AID PROJECT

MODEL: Sheet  
 FILE NAME: p:\transsystems-pw\beniley.com\TRANSYSORP-PW1-HOSTED\Documents\Projects\_2018\CH401\40118002202-TransSystems\CAD\62R30\Sheets\2-Structural\099-8324-CR-03-01B-Railing\_Detail.dgn  
 9/28/2022 11:00:35 AM

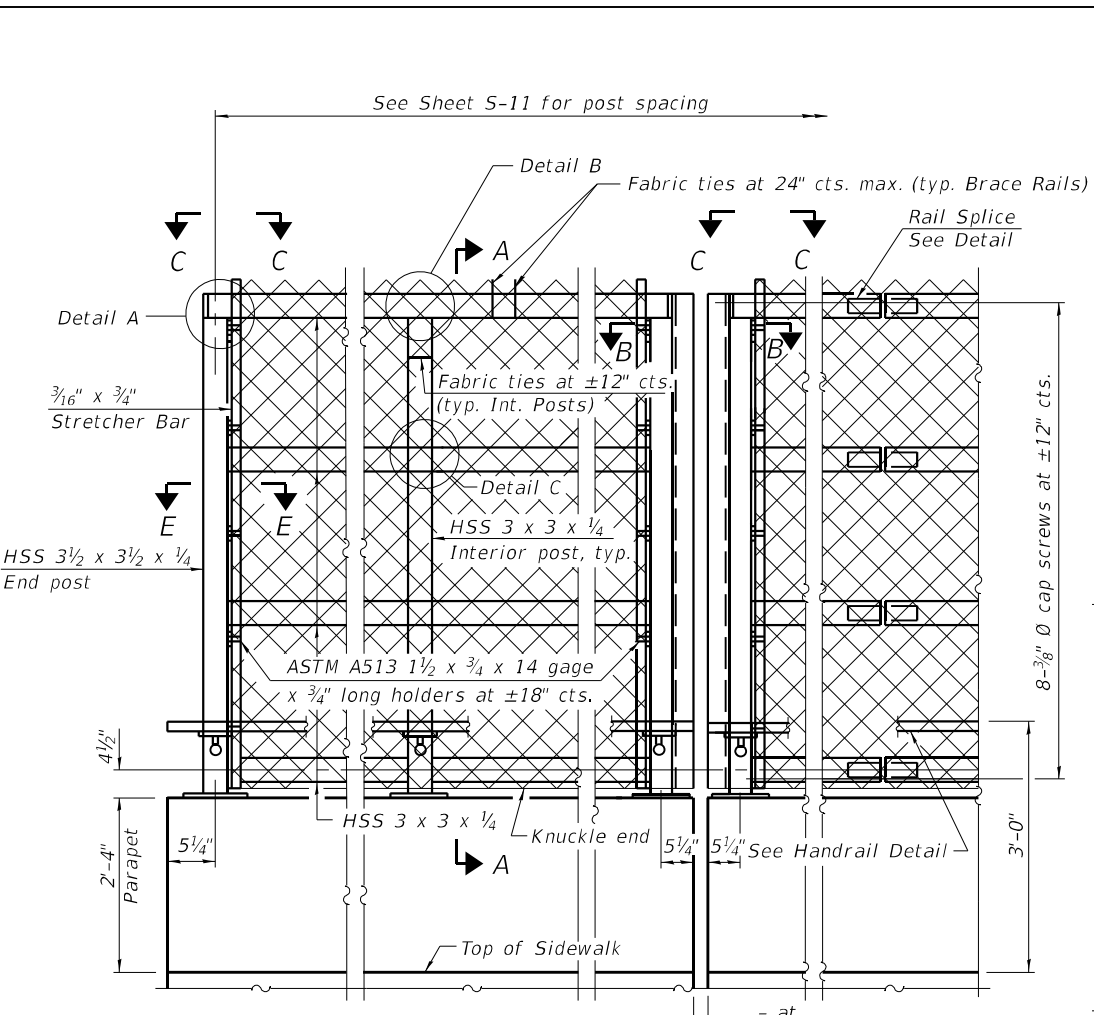

**ELEVATION**  
(Inside Face)

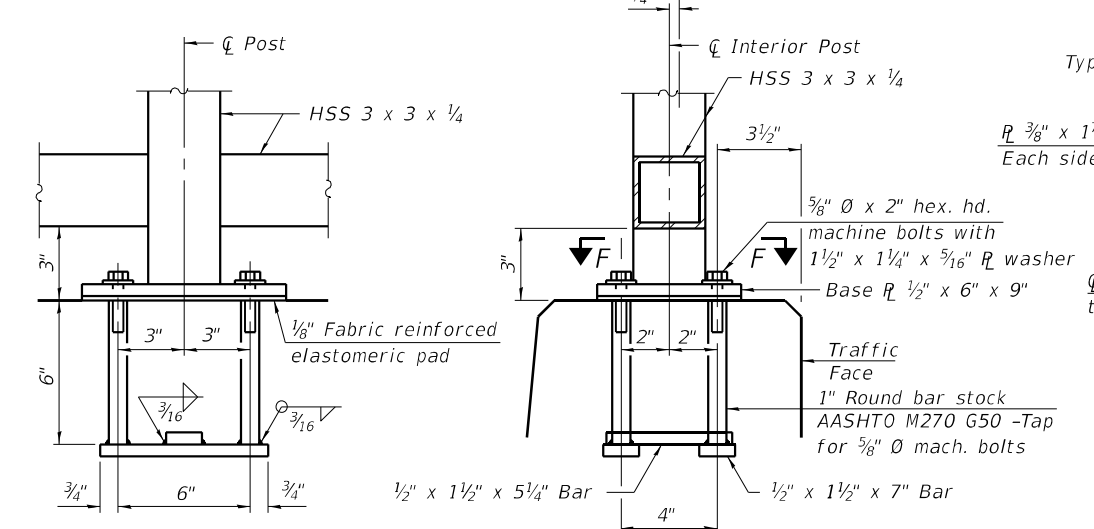

**ANCHOR BOLT DETAILS**

In lieu of the cast-in-place anchor device shown, the Contractor has the option of drilling and setting 5/8" Ø anchor rods according to Article 509.06 of the Standard Specifications. Embedment shall be according to the manufacturer's specifications. Place reinforcement bars to miss anchor rod locations.

**RAILING CRITERIA**

NCHRP 350 Test Level	4
Railing Weight (plf)	70
Max Post Spacing	10'-0"

R-32 10-12-2021

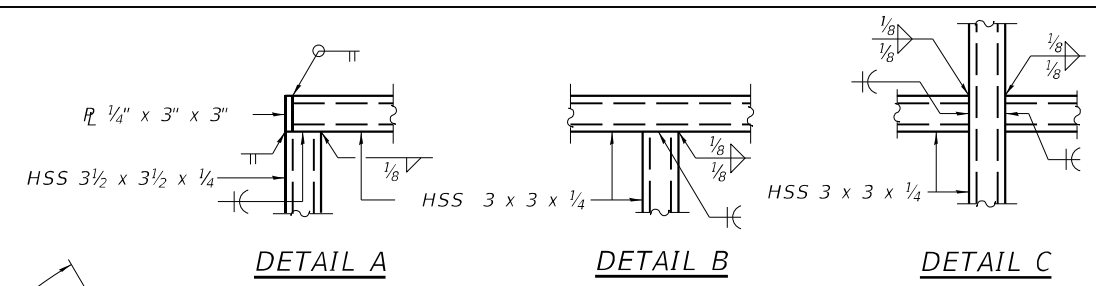

**DETAIL A**      **DETAIL B**      **DETAIL C**

**NOTES:**

- All steel rail elements shall be galvanized according to Article 509.05 of the Standard Specifications.
- This work will be paid for at the unit cost per foot of Bridge Fence Railing, Curved.

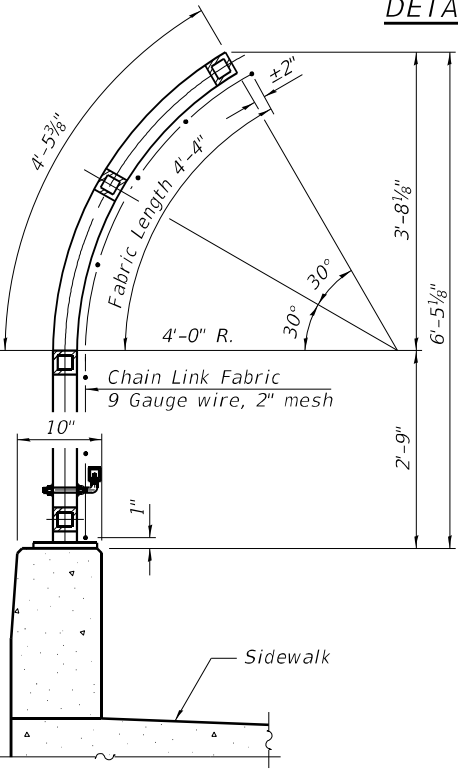

**SECTION A-A**

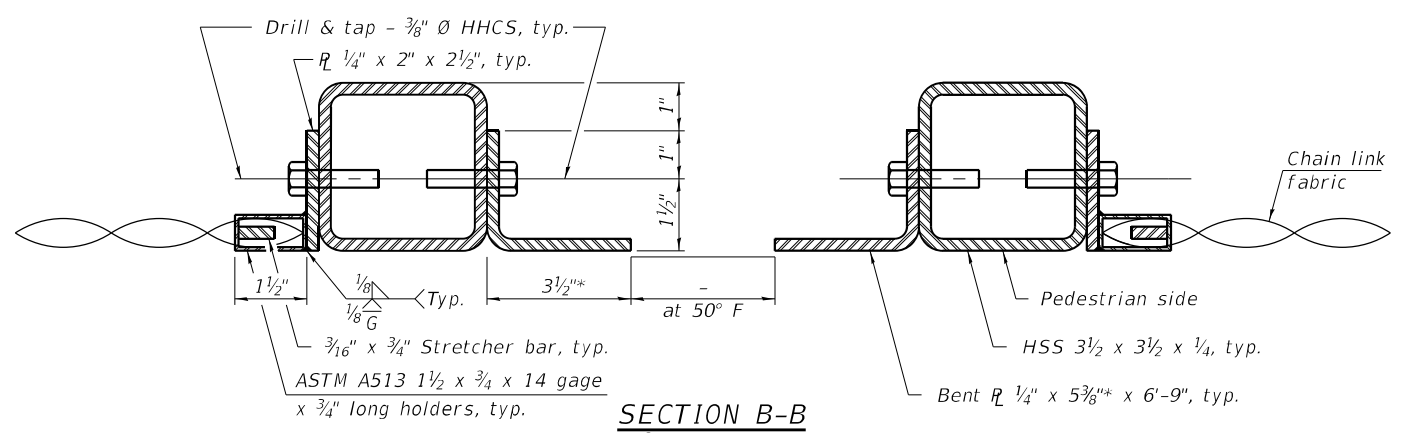

**SECTION B-B**

\* Assume 3/8" radius. Dimensions may need to be modified for larger joints to avoid gaps greater than 6".

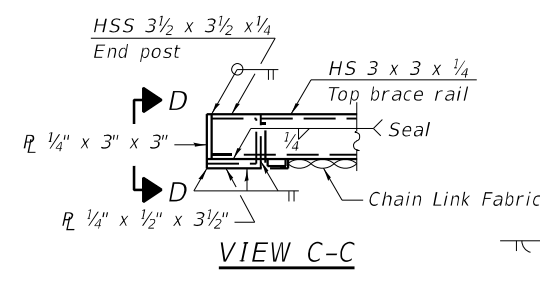

**VIEW C-C**

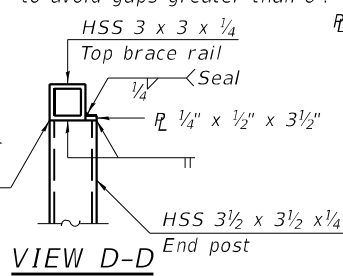

**VIEW D-D**

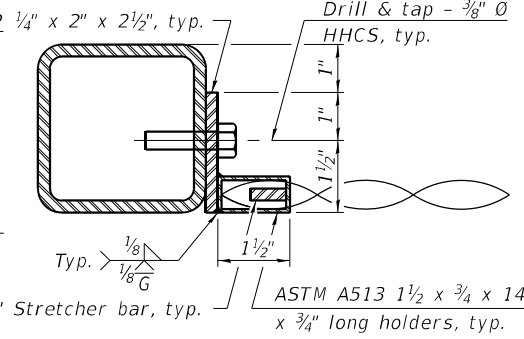

**SECTION E-E**

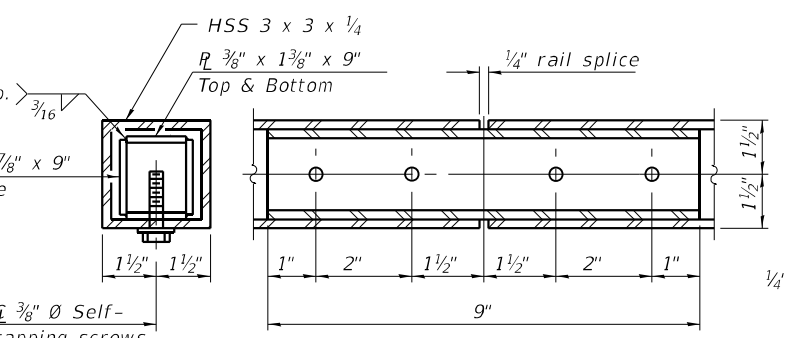

**RAIL SPLICE**

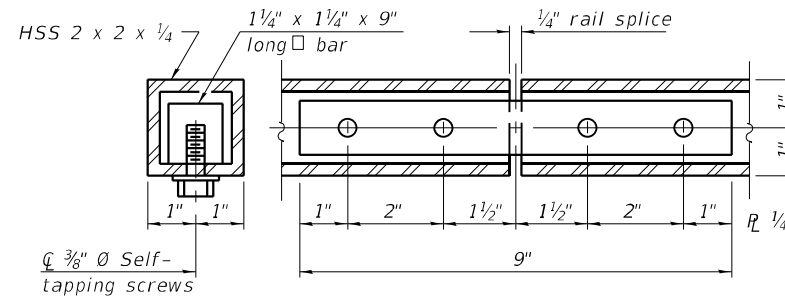

**HANDRAIL SPLICE**

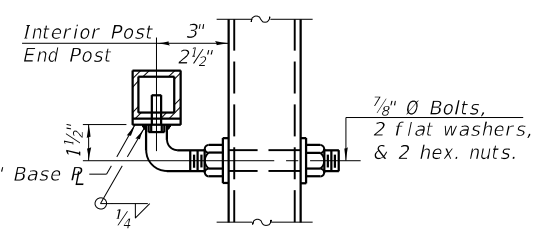

**HANDRAIL DETAIL**

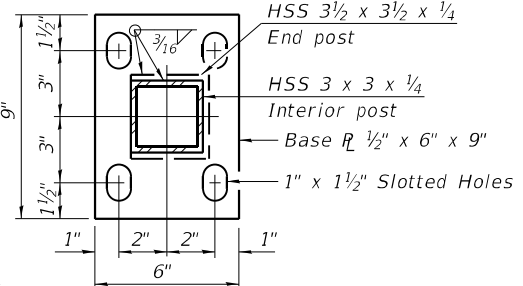

**SECTION F-F**

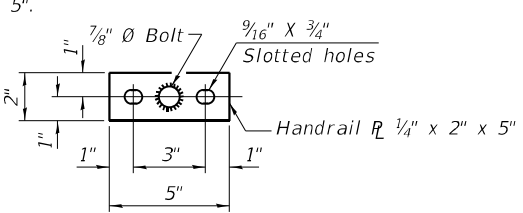

**SECTION G-G**  
(Handrail)

**BILL OF MATERIAL**

Item	Unit	Quantity
Bridge Fence Railing, Curved	Foot	486

**NOTES:**

- Cost of handrail included with Bridge Fence Railing, Curved.  
 CVN testing is not required for the HSS tubing.  
 Place reinforcement bars to miss anchor bolt locations.



USER NAME =	DESIGNED - MK	REVISED -
PLOT SCALE =	CHECKED - DD	REVISED -
PLOT DATE =	DRAWN - MK	REVISED -
	CHECKED - DD	REVISED -

**STATE OF ILLINOIS**  
**DEPARTMENT OF TRANSPORTATION**

**BRIDGE FENCE RAILING, CURVED**  
**STRUCTURE NO. 099-8324**

SHEET S-18 OF S-31 SHEETS

FAI RTE.	SECTION	COUNTY	TOTAL SHEETS	SHEET NO.
80	FAI 80 21 STRUCTURE 9	WILL	130	75
			CONTRACT NO. 62R30	
ILLINOIS FED. AID PROJECT				

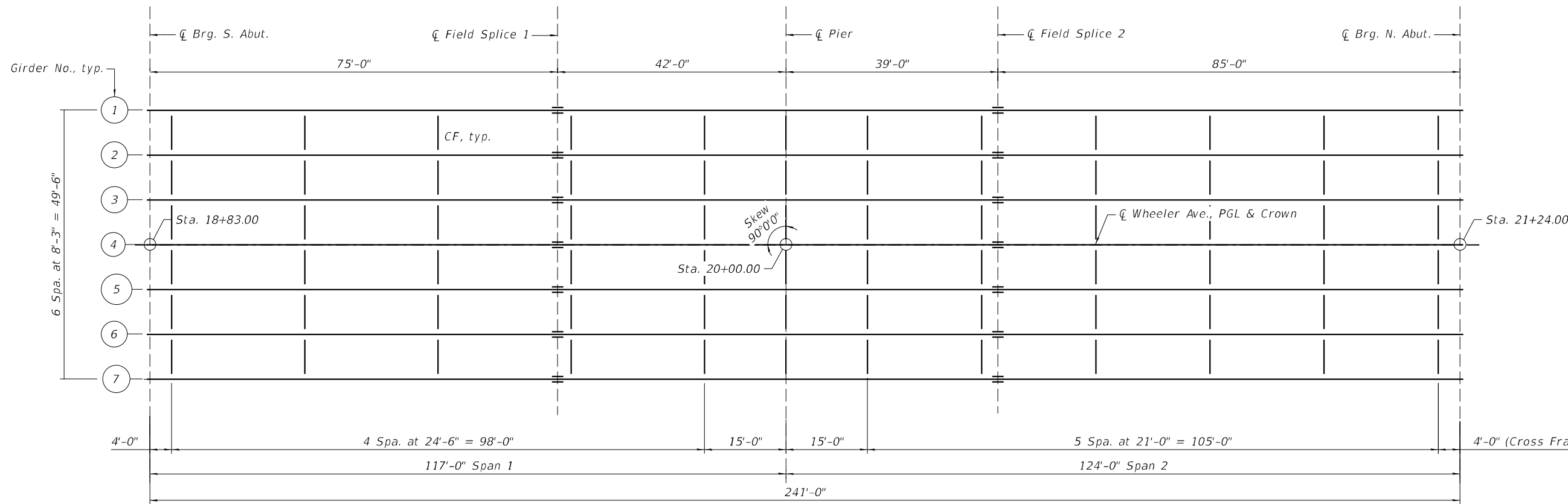
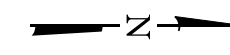

**FRAMING PLAN**

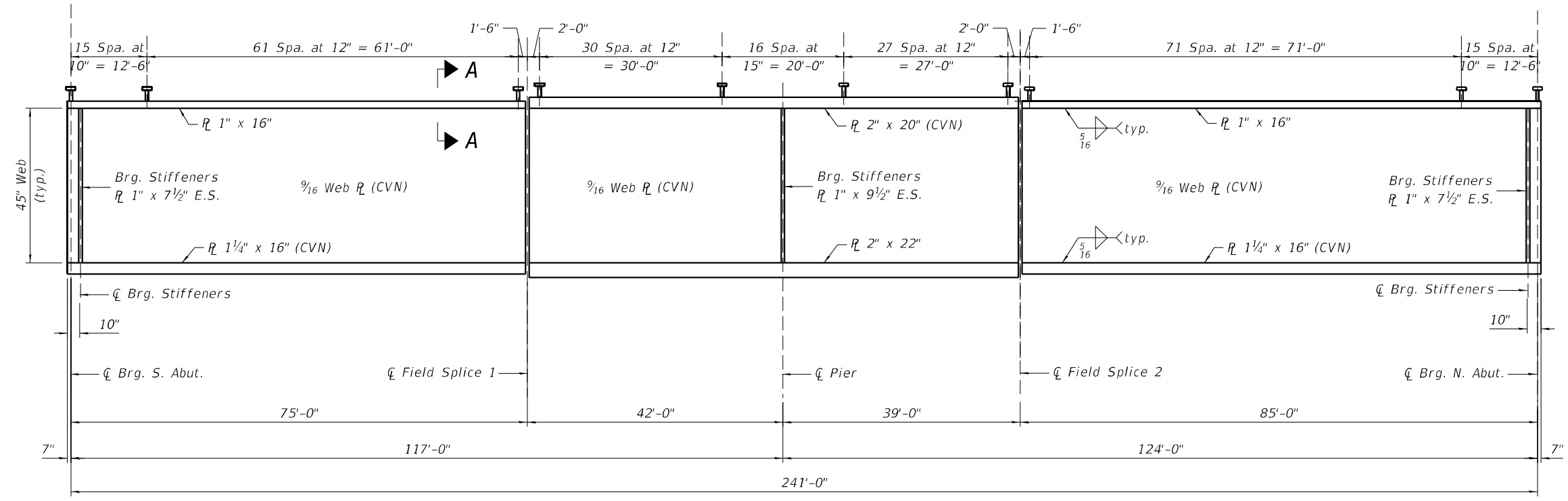

**GIRDER ELEVATION**

"CVN" denotes Charpy-V-Notch impact energy requirements, zone 2.

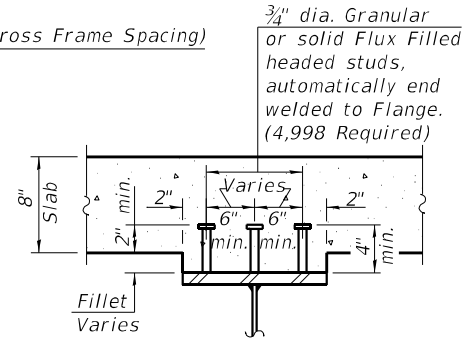

**SECTION A-A**

**NOTES**

- All structural steel shall be AASHTO M270 Grade 50.
- E.S. = Each Side
- For Bridge Mount Sign Structures, see Roadway Plans.

MODEL: Sheet  
FILE NAME: pw://transsystems-pw.bentley.com/TRANSYS/Projects\_2018/CH401/40118002202-TransSystems/CAD/62830/Sheets/2-Structural/099-8324-CR-03-019-FramingGirderElev.dgn



USER NAME =	DESIGNED - MK	REVISED -
	CHECKED - DD	REVISED -
PLOT SCALE =	DRAWN - MK	REVISED -
PLOT DATE =	CHECKED - DD	REVISED -

**STATE OF ILLINOIS  
DEPARTMENT OF TRANSPORTATION**

**FRAMING PLAN AND GIRDER ELEVATION  
STRUCTURE NO. 099-8324**

SHEET S-19 OF S-31 SHEETS

F.A.I. RTE.	SECTION	COUNTY	TOTAL SHEETS	SHEET NO.
80	FAI 80 21 STRUCTURE 9	WILL	130	76
CONTRACT NO. 62R30				
		ILLINOIS	FED. AID PROJECT	

MODEL: Sheet  
 FILE NAME: pw://transsystems-pw.bentley.com:TRANSSYSTEMS-CAD/62R30/SHEETS/2-3-Structural/099-8324/0998324-CR-03-03-Non-Tables.dgn

INTERIOR GIRDER MOMENT TABLE				
		0.4 Sp. 1	Pier	0.6 Sp. 2
$I_s$	(in <sup>4</sup> )	23,289	50,608	23,289
$I_c(n)$	(in <sup>4</sup> )	56,959	-	56,959
$I_c(3n)$	(in <sup>4</sup> )	42,717	-	42,717
$I_c(cr)$	(in <sup>4</sup> )	-	57,192	-
$S_s$	(in <sup>3</sup> )	1,049	2,141	1,049
$S_c(n)$	(in <sup>3</sup> )	1,396	-	1,396
$S_c(3n)$	(in <sup>3</sup> )	1,294	-	1,294
$S_c(cr)$	(in <sup>3</sup> )	-	2,229	-
DC1	(k')	1.11	1.28	1.11
MDC1	(k)	841	2594	1072
DC2	(k')	0.37	0.37	0.37
MDC2	(k)	293	787	368
DW	(k')	0.41	0.41	0.41
MDW	(k)	327	877	410
LLDF		0.605	0.635	0.596
$M_L + IM$	(k)	1,640	2,220	1,725
$M_U$ (Strength I)	(k)	4,778	9,427	5,434
$\Phi_f M_n$	(k)	7,022	10,209	6,875
$f_s$ DC1	(ksi)	9.6	14.5	12.3
$f_s$ DC2	(ksi)	2.7	4.2	3.4
$f_s$ DW	(ksi)	3.0	4.7	3.8
$f_s$ ( $\frac{1}{2}$ IM)	(ksi)	14.1	12.0	14.8
$f_s$ (Service II)	(ksi)	33.7	39.0	38.8
$0.95R_f F_y f$	(ksi)	47.5	47.5	47.5
$f_s$ (Total)(Strength I)	(ksi)	-	-	-
$\Phi_f F_n$	(ksi)	-	-	-
Vf	(k)	35.8	36.3	37.2

GIRDER REACTION TABLE						
	S. Abut.		Pier		N. Abut.	
	Interior	Exterior	Interior	Exterior	Interior	Exterior
LLDF	0.832	0.800	0.832	0.800	0.832	0.800
OCF	-	1.000	-	-	-	1.000
RDC1	(k) 44.9	39.7	188.5	168.1	50.1	44.4
RDC2	(k) 14.9	14.9	57.7	57.7	16.6	16.6
RDW	(k) 16.6	12.9	64.3	49.9	18.5	14.3
$R_L$	(k) 80.5	77.4	168.8	162.3	82.1	78.9
RIM	(k) 17.7	17.1	31.1	29.9	17.8	17.1
RTOTAL	(k) 174.7	162.0	510.3	467.9	185.1	171.3

$I_s, S_s$ : Non-composite moment of inertia and section modulus of the steel section used for computing  $f_s$  (Total-Strength I, and Service II) due to non-composite dead loads (in<sup>4</sup> and in<sup>3</sup>).

$I_c(n), S_c(n)$ : Composite moment of inertia and section modulus of the steel and deck based upon the modular ratio, "n", used for computing  $f_s$  (Total-Strength I, and Service II) in uncracked sections due to short-term composite live loads (in<sup>4</sup> and in<sup>3</sup>).

$I_c(3n), S_c(3n)$ : Composite moment of inertia and section modulus of the steel and deck based upon 3 times the modular ratio, "3n", used for computing  $f_s$  (Total-Strength I, and Service II) in uncracked sections, due to long-term composite (superimposed) dead loads (in<sup>4</sup> and in<sup>3</sup>).

$I_c(cr), S_c(cr)$ : Composite moment of inertia and section modulus of the steel and longitudinal deck reinforcement, used for computing  $f_s$  (Total-Strength I and Service II) in cracked sections, due to both short-term composite live loads and long-term composite (superimposed) dead loads (in<sup>4</sup> and in<sup>3</sup>).

DC1: Un-factored non-composite dead load (kips/ft.).  
 $M_{DC1}$ : Un-factored moment due to non-composite dead load (kip-ft.).  
 DC2: Un-factored long-term composite (superimposed excluding future wearing surface) dead load (kips/ft.).  
 $M_{DC2}$ : Un-factored moment due to long-term composite (superimposed excluding future wearing surface) dead load (kip-ft.).  
 DW: Un-factored long-term composite (superimposed future wearing surface only) dead load (kips/ft.).  
 $M_{DW}$ : Un-factored moment due to long-term composite (superimposed future wearing surface only) dead load (kip-ft.).  
 $M_L + IM$ : Un-factored live load moment plus dynamic load allowance (impact) (kip-ft.).  
 $M_U$  (Strength I): Factored design moment (kip-ft.).  
 $1.25 (M_{DC1} + M_{DC2}) + 1.5 M_{DW} + 1.75 M_L + IM$   
 $\Phi_f M_n$ : Compact composite positive moment capacity computed according to Article 6.10.7.1 or non-slender negative moment capacity according to Article A6.1.1 or A6.1.2 (kip-ft.).  
 $f_s$  DC1: Un-factored stress at edge of Flange for controlling steel Flange due to vertical non-composite dead loads as calculated below (ksi).  
 $M_{DC1} / S_s$   
 $f_s$  DC2: Un-factored stress at edge of Flange for controlling steel Flange due to vertical composite dead loads as calculated below (ksi).  
 $M_{DC2} / S_c(3n)$  or  $M_{DC2} / S_c(cr)$  as applicable.  
 $f_s$  DW: Un-factored stress at edge of Flange for controlling steel Flange due to vertical composite future wearing surface loads as calculated below (ksi).  
 $M_{DW} / S_c(3n)$  or  $M_{DW} / S_c(cr)$  as applicable.  
 $f_s$  ( $\frac{1}{2}$ IM): Un-factored stress at edge of Flange for controlling steel Flange due to vertical composite live load plus impact loads as calculated below (ksi).  
 $M_L + IM / S_c(n)$  or  $M_L + IM / S_c(cr)$  as applicable.  
 $f_s$  (Service II): Sum of stresses as computed below (ksi).  
 $f_{SDC1} + f_{SDC2} + f_{SDW} + 1.3 f_s (\frac{1}{2} + IM)$   
 $0.95R_f F_y f$ : Composite stress capacity for Service II loading according to Article 6.10.4.2 (ksi).  
 $f_s$  (Total)(Strength I): Sum of stresses as computed below on non-compact section (ksi).  
 $1.25 (f_{SDC1} + f_{SDC2}) + 1.5 f_{SDW} + 1.75 f_s (\frac{1}{2} + IM)$   
 $\Phi_f F_n$ : Non-Compact composite positive or negative stress capacity for Strength I loading according to Article 6.10.7 or 6.10.8 (ksi).  
 Vf: Maximum factored shear range in span computed according to Article 6.10.10.  
 LLDF: Live Load Distribution Factor  
 OCF: Obtuse Correction Factor



USER NAME =	DESIGNED - MK	REVISED -
	CHECKED - DD	REVISED -
PLOT SCALE =	DRAWN - MK	REVISED -
PLOT DATE =	CHECKED - DD	REVISED -

STATE OF ILLINOIS  
 DEPARTMENT OF TRANSPORTATION

GIRDER MOMENT AND REACTION TABLES  
 STRUCTURE NO. 099-8324

SHEET S-20 OF S-31 SHEETS

F.A.I. RTE.	SECTION	COUNTY	TOTAL SHEETS	SHEET NO.
80	FAI 80 21 STRUCTURE 9	WILL	130	77
			CONTRACT NO. 62R30	
		ILLINOIS	FED. AID PROJECT	

MODEL: Sheet  
 FILE NAME: pw://transystems-pw.bentley.com:TRANSSYSTEMS/Projects\_2018/CH401/401180022/02-TransSystems/CAD/62R30/Sheets/2-Structural/099-8324-CR-03-02-1-Gird-Camber.dgn

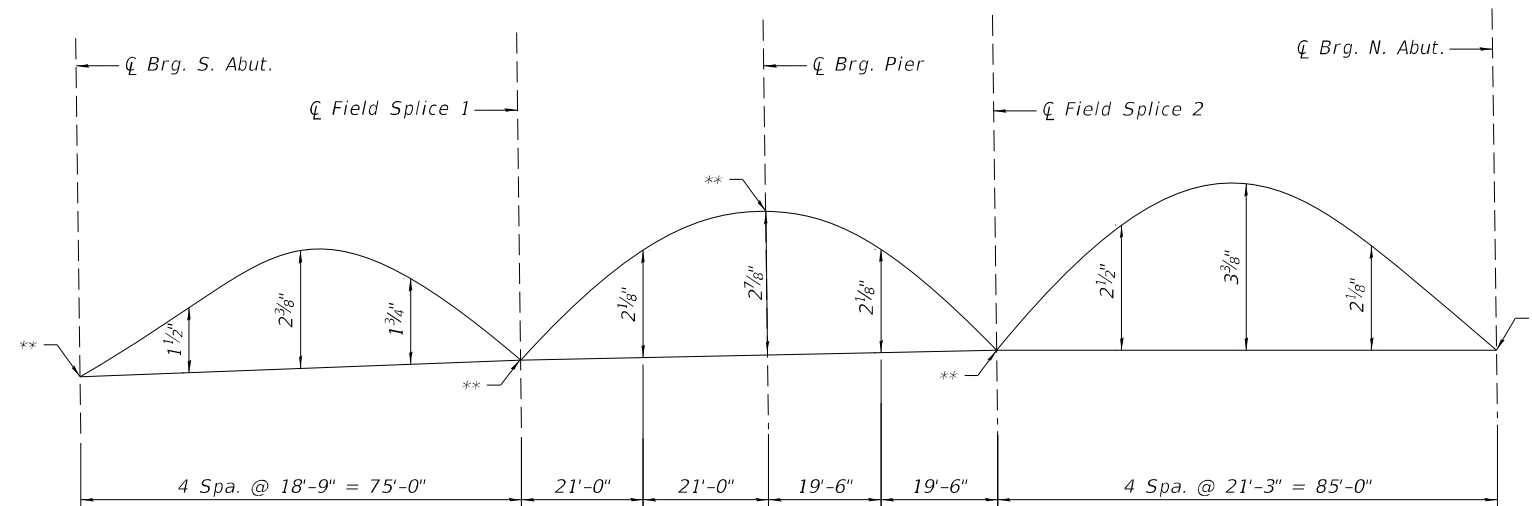

**CAMBER DIAGRAM**

\*\* Top of Web Elevations

TOP OF WEB ELEVATIONS* (in feet)					
Girder	☐ Brg. S. Abut.	☐ Splice 1	☐ Brg. Pier	☐ Splice 2	☐ Brg. N. Abut.
1	635.93	637.80	638.37	638.44	637.38
2	636.09	637.96	638.53	638.60	637.54
3	636.22	638.08	638.65	638.72	637.67
4	636.34	638.21	638.78	638.85	637.79
5	636.22	638.08	638.65	638.72	637.67
6	636.09	637.96	638.53	638.60	637.54
7	635.93	637.80	638.37	638.44	637.38

\*For fabrication use only.



USER NAME =	DESIGNED - MK	REVISED -
	CHECKED - DD	REVISED -
PLOT SCALE =	DRAWN - MK	REVISED -
PLOT DATE =	CHECKED - DD	REVISED -

STATE OF ILLINOIS  
 DEPARTMENT OF TRANSPORTATION

GIRDER CAMBER DIAGRAM  
 STRUCTURE NO. 099-8324

SHEET S-21 OF S-31 SHEETS

F.A.I. RTE.	SECTION	COUNTY	TOTAL SHEETS	SHEET NO.
80	FAI 80 21 STRUCTURE 9	WILL	130	78
CONTRACT NO. 62R30				
ILLINOIS		FED. AID PROJECT		

MODEL: Sheet  
 FILE NAME: pw://transystems-pw.bentley.com:TRANSYS/SCORP-PW1-HOSTED/Projects\_2018/CH401/40118002202-TransSystems/CAD/62R30/Sheets/2-Structural/099-8324/0998324-CF-03-022-Steel-Details.dgn  
 9/28/2022 11:02:26 AM

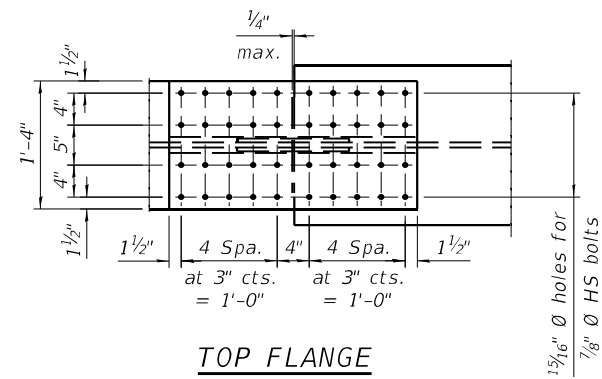

**TOP FLANGE**

15/16" Ø holes for  
7/8" Ø HS bolts

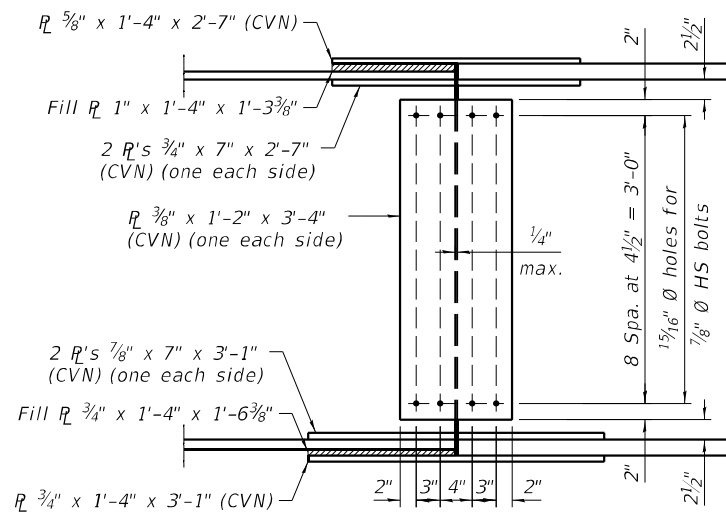

**ELEVATION**

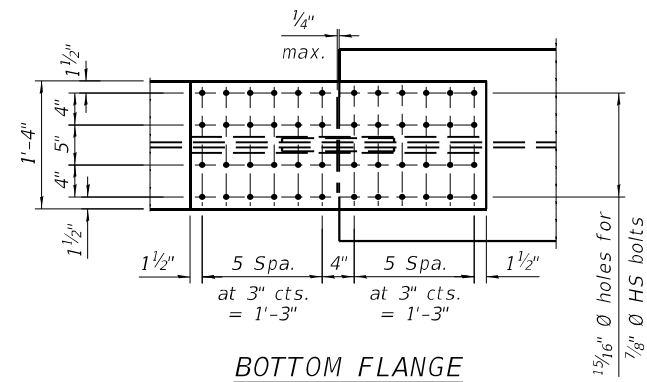

**FIELD SPLICE DETAIL**

(14 Required)

15/16" Ø holes for  
7/8" Ø HS bolts

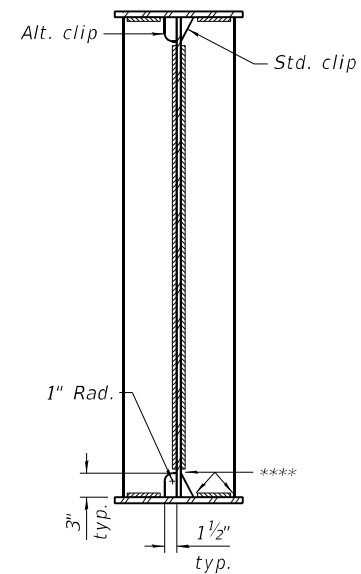

**WELD LIMITS AND CLIP DETAILS**

\*\*\*\* Stop welds 1/4" (± 1/8")  
from edges as shown. Typical.

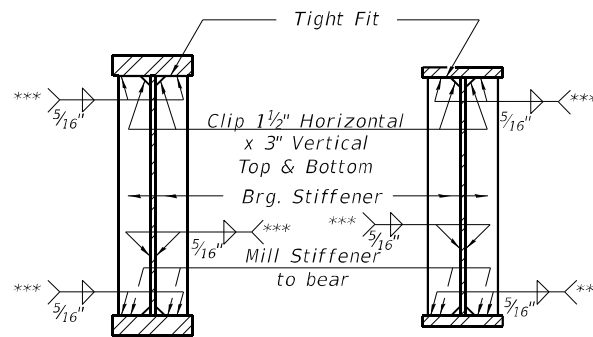

**SECTION  
AT PIER**

**SECTION  
AT ABUTMENT**

\*\*\* Terminate 1/4" (± 1/8")  
from end of plate intersects.

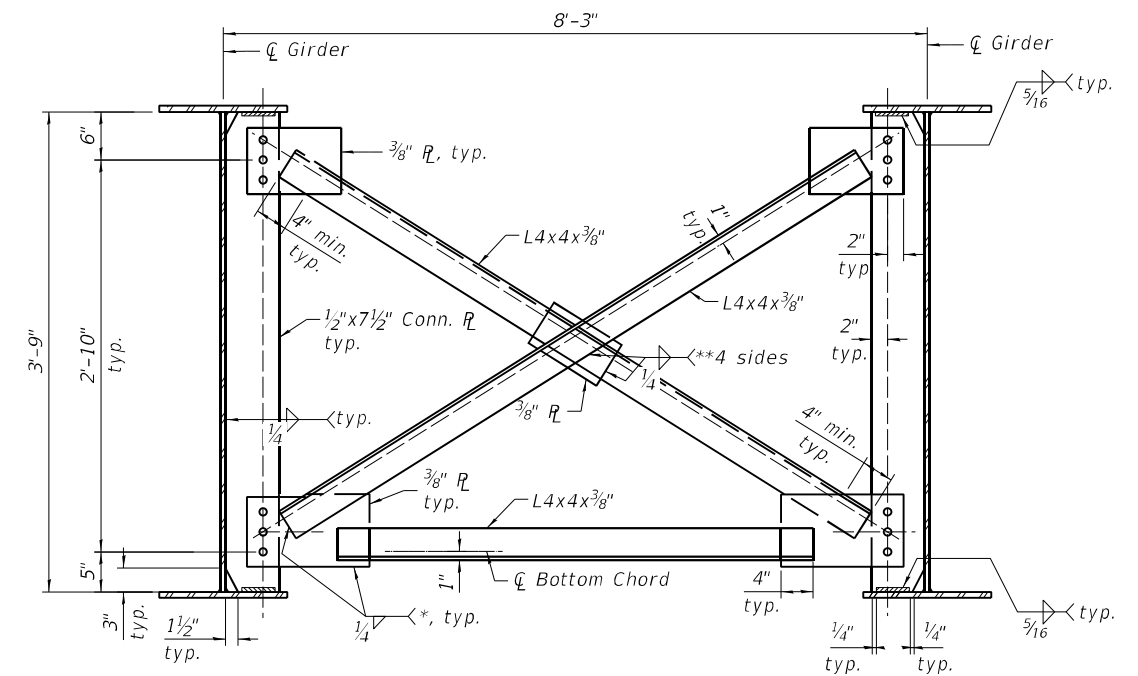

**CROSS FRAME - CF**

(72 Required)

Note: Two hardened washers required for each set  
of oversized holes.

\* Fillet weld angles along 3 sides on one face of gusset plate; however,  
if cross-frame are galvanized, weld all-around.

\*\* If cross-frames are galvanized, weld all-around.

**NOTES:**

- "CVN" denotes Charpy-V-Notch impact energy requirements, zone 2.
- All structural steel for girders, bearing stiffener plates and splice plates except fill plates shall be AASHTO M270 Grade 50.
- All cross frames shall be installed as steel is erected and secured with erection pins and bolts, except as otherwise noted. Individual cross frames at supports may be temporarily disconnected to install bearing anchor rods.



USER NAME =	DESIGNED - MK	REVISED -
PLOT SCALE =	CHECKED - DD	REVISED -
PLOT DATE =	DRAWN - MK	REVISED -
	CHECKED - DD	REVISED -

**STATE OF ILLINOIS  
DEPARTMENT OF TRANSPORTATION**

**STEEL DETAILS  
STRUCTURE NO. 099-8324**

SHEET S-22 OF S-31 SHEETS

F.A.I. RTE.	SECTION	COUNTY	TOTAL SHEETS	SHEET NO.
80	FAI 80 21 STRUCTURE 9	WILL	130	79
CONTRACT NO. 62R30				
ILLINOIS FED. AID PROJECT				

MODEL: Sheet  
 FILE NAME: pw://transystems-pw.bentley.com:TRANSSYSORP-PW1-HOSTED/Documents/Projects\_2018/CH401/401180022/02-TransSystems/CAD/62R30/Sheets/2-Structural/099-8324-CR-03-02-3-Bearing-Details.dgn

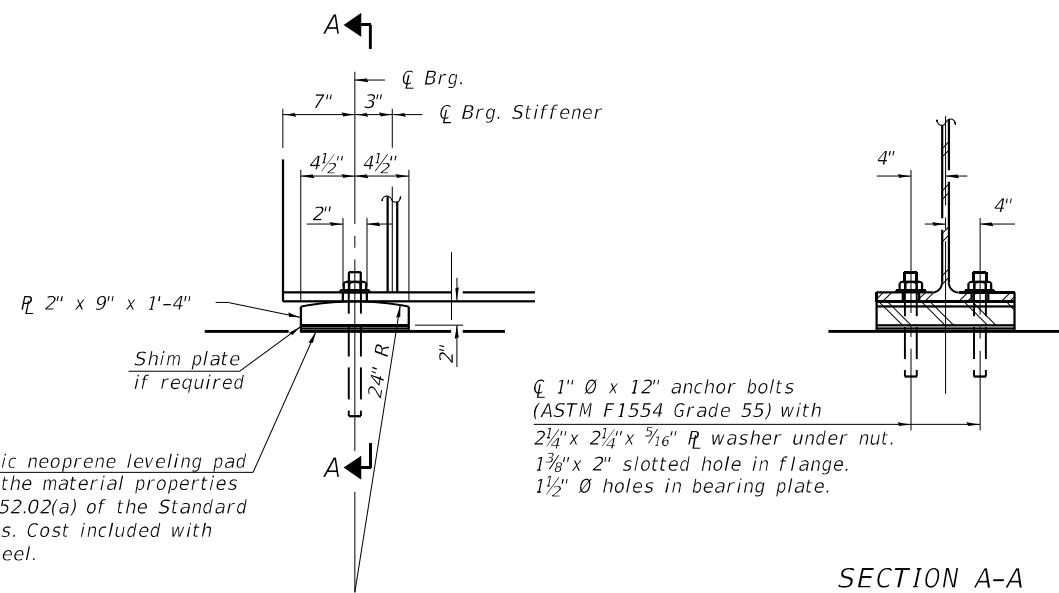

**ELEVATION AT ABUTMENT**

**FIXED BEARING - ABUTMENTS**

1"  $\phi$  x 12" anchor bolts  
 (ASTM F1554 Grade 55) with  
 2 1/4" x 2 1/4" x 5/16"  $R_L$  washer under nut.  
 1 3/8" x 2" slotted hole in flange.  
 1 1/2"  $\phi$  holes in bearing plate.

**SECTION A-A**

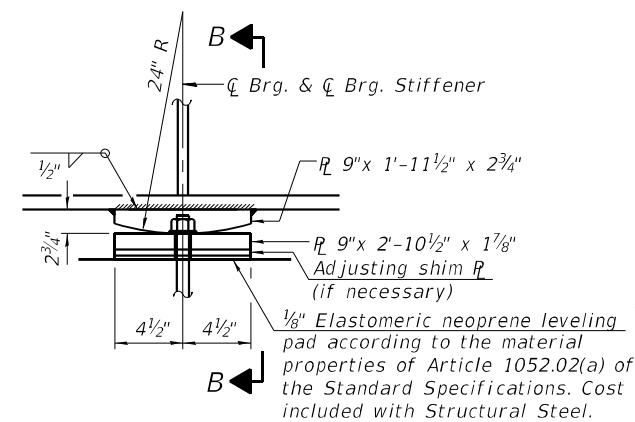

**ELEVATION AT PIER**

**FIXED BEARING - PIER**

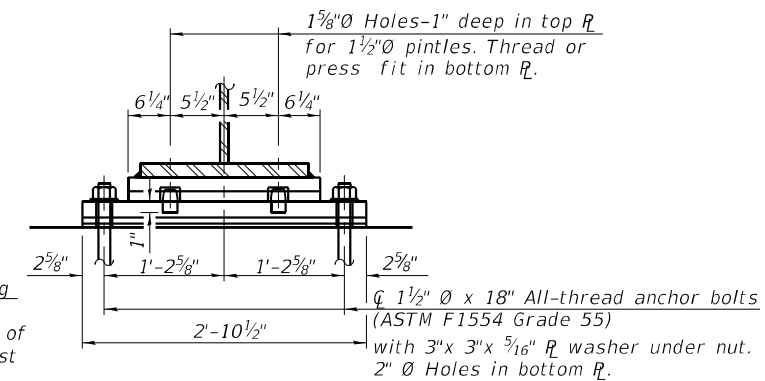

**SECTION B-B**

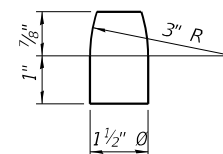

**PINTLE**

**NOTES:**

- Anchor bolts at all supports shall be installed as each member is erected unless an equivalent temporary means of lateral restraints is used.
- Fixed Bearing Assembly included in "Furnishing and Erecting Structural Steel."
- Two 1/8 in. adjusting shims shall be provided for each bearing in addition to all other plates or shims and placed as shown on bearing details.
- The structural steel plates and pintles of the Bearing shall conform to the requirements of AASHTO M270 Grade 50.

**BILL OF MATERIAL**

Item	Unit	Total
Anchor Bolts, 1"	Each	28
Anchor Bolts, 1 1/2"	Each	14



USER NAME =	DESIGNED - MK	REVISED -
	CHECKED - DD	REVISED -
PLOT SCALE =	DRAWN - MK	REVISED -
PLOT DATE =	CHECKED - DD	REVISED -

**STATE OF ILLINOIS  
DEPARTMENT OF TRANSPORTATION**

**BEARING DETAILS  
STRUCTURE NO. 099-8324**

SHEET S-23 OF S-31 SHEETS

F.A.I. RTE.	SECTION	COUNTY	TOTAL SHEETS	SHEET NO.
80	FAI 80 21 STRUCTURE 9	WILL	130	80
CONTRACT NO. 62R30				
ILLINOIS FED. AID PROJECT				



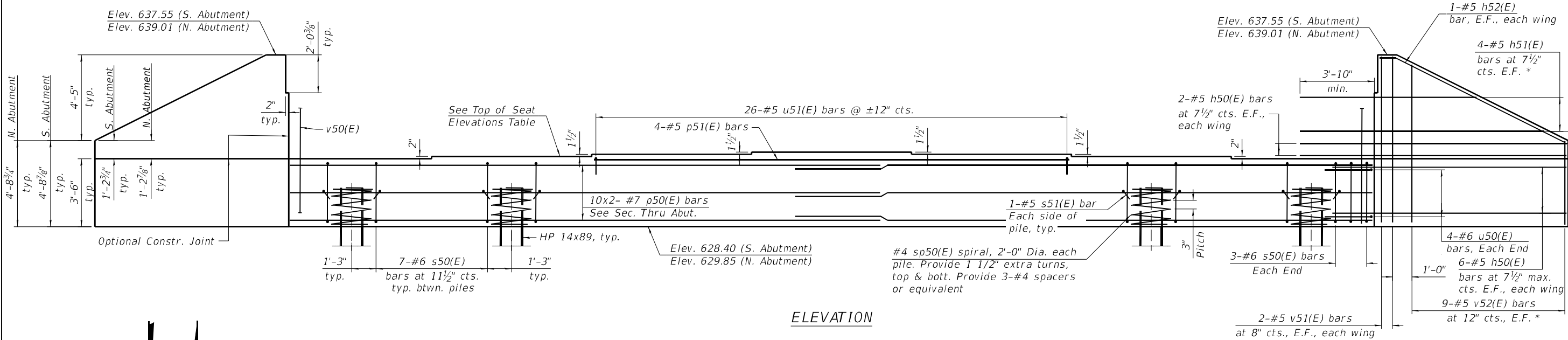

ELEVATION

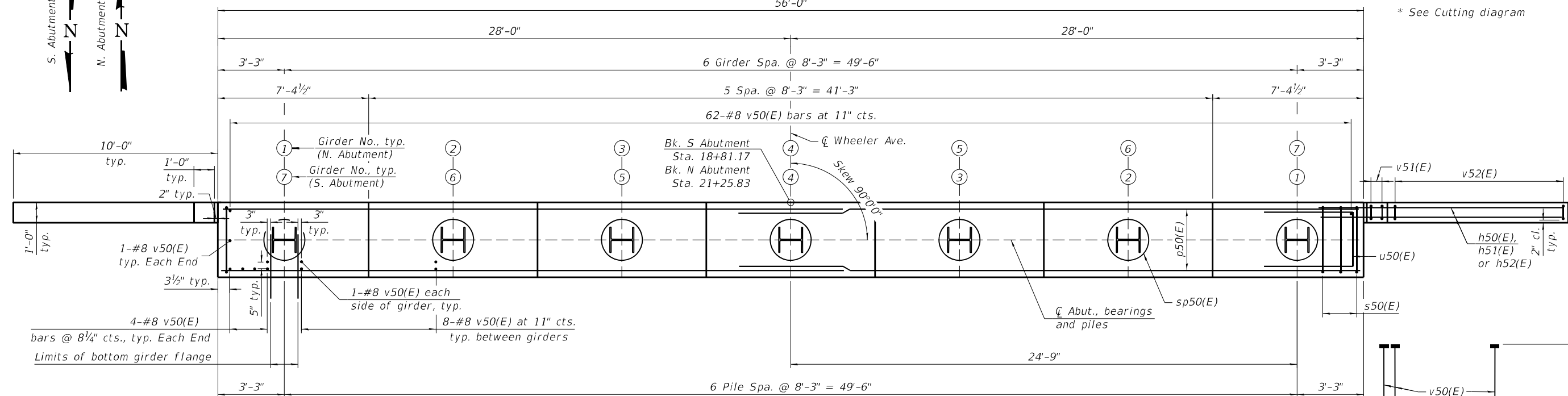

PLAN

TOP OF SEAT ELEVATIONS S. ABUTMENT

Gdr. No	Seat Elev.
1	631.90
2	632.06
3	632.18
4	632.31
5	632.18
6	632.06
7	631.90

TOP OF SEAT ELEVATIONS N. ABUTMENT

Gdr. No	Seat Elev.
1	633.35
2	633.51
3	633.63
4	633.76
5	633.63
6	633.51
7	633.35

PILE DATA - SOUTH ABUT.

Type: HP 14x89 w/ Pile Shoes  
 Nominal Required Bearing: 705 kips  
 Factored Resistance Available: 388 kips  
 Est. Length: 44 ft.  
 No. Production Piles: 6  
 No. Test Piles: 1

PILE DATA - NORTH ABUT.

Type: HP 14x89 w/ Pile Shoes  
 Nominal Required Bearing: 705 kips  
 Factored Resistance Available: 388 kips  
 Est. Length: 40 ft.  
 No. Production Piles: 6  
 No. Test Piles: 1

NOTES

- See Sheet S-25 for Bar List & Bill of Material.
- For details of piles, see Sheet S-28.
- Pour steps monolithically with cap.
- E.F. indicates Each Face.

MIN. BAR LAP

#7 bar = 6'-3"

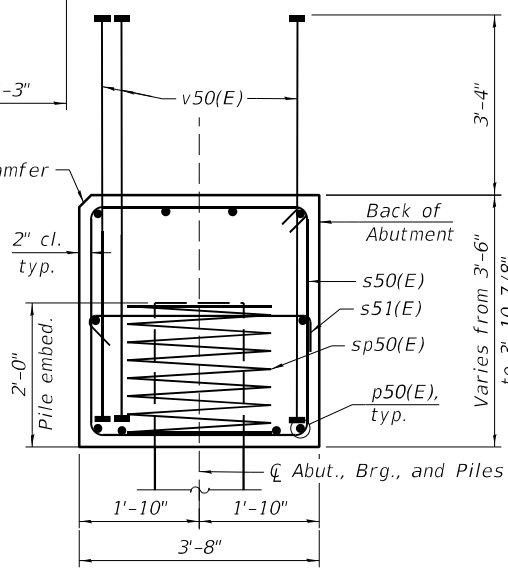

SECTION THRU ABUTMENT

MODEL: Sheet  
 FILE NAME: pw://transystems-pw.bentley.com:TRANSYSORP-PW1-HOSTED/Projects/2018/CH401/40118002202-Transystems/CAD/628305/Sheets/S-3-Structural/099-8324-CR-03-024- Abutment.dgn  
 9/28/2022 11:02:43 AM



USER NAME =	DESIGNED - MK	REVISED -
PLOT SCALE =	CHECKED - DD	REVISED -
PLOT DATE =	DRAWN - MK	REVISED -
	CHECKED - DD	REVISED -

STATE OF ILLINOIS  
 DEPARTMENT OF TRANSPORTATION

ABUTMENT PLAN & ELEVATION  
 STRUCTURE NO. 099-8324

SHEET S-24 OF S-31 SHEETS

F.A.I. RTE.	SECTION	COUNTY	TOTAL SHEETS	SHEET NO.
80	FAI 80 21 STRUCTURE 9	WILL	130	81

CONTRACT NO. 62R30

ILLINOIS FED. AID PROJECT

MODEL: Sheet  
 FILE NAME: pw://transystems-pw.bentley.com/TRANSSYS/Projects\_2018/CH401/401180022/02-TransSystems/CAD/62R30/Sheets/2-Structural/099-8324/0998324-CR-03-025-AbutmentDetails.dgn  
 9/28/2022 11:02:52 AM

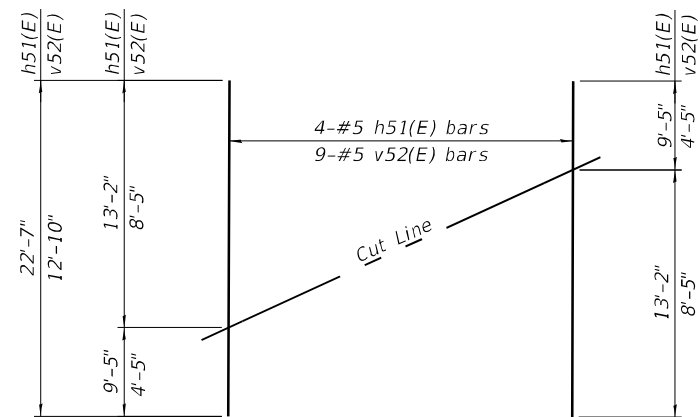

**FIELD CUTTING DIAGRAM**

Order h51(E) and v52(E) full length. Cut as shown and use remainder of bars in opposite wing.

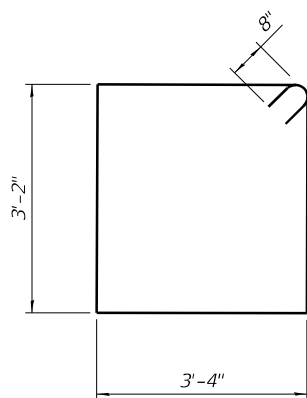

**BAR s50(E)**

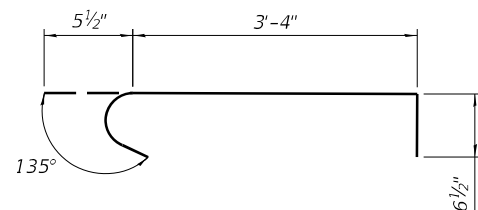

**BAR s51(E)**

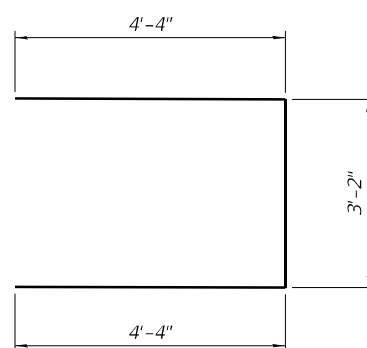

**BAR u50(E)**

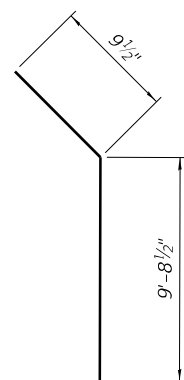

**BAR h52(E)**

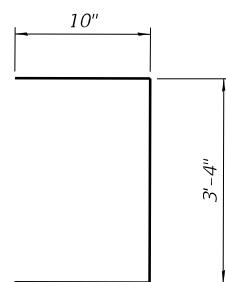

**BAR u51(E)**

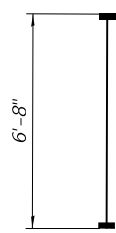

**BAR v50(E)**  
(Headed)

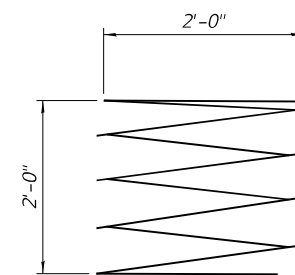

**BAR sp50(E)**

Headed bars shall conform to ASTM A970 with threaded attachment; Class HA; and reinforcement bars conforming to ASTM A706. Cost included with Reinforcement Bars, Epoxy Coated.

**BILL OF MATERIAL**  
**S. ABUTMENT**

Bar	No.	Size	Length	Shape
h50(E)	32	#5	13'-8"	—
h51(E)	8	#5	22'-7"	—
h52(E)	4	#5	10'-6"	—
p50(E)	20	#7	31'-0"	—
p51(E)	4	#5	24'-5"	—
s50(E)	48	#6	14'-4"	□
s51(E)	14	#5	4'-4"	└┘
sp50(E)	7	#4	2'-0"	WWW
u50(E)	8	#6	11'-10"	└┘
u51(E)	26	#5	5'-0"	└┘
v50(E)	134	#8	6'-8"	—
v51(E)	8	#5	8'-10"	—
v52(E)	18	#5	12'-10"	—
Structure Excavation	Cu. Yd.	290.6		
Concrete Structures	Cu. Yd.	33.4		
Reinforcement Bars, Epoxy Coated	Pounds	6,460		
Furnishing Steel Piles HP 14x89	Foot	264		
Driving Piles	Foot	264		
Test Pile Steel HP 14x89	Each	1		
Pile Shoes	Each	7		

**BILL OF MATERIAL**  
**N. ABUTMENT**

Bar	No.	Size	Length	Shape
h50(E)	32	#5	13'-8"	—
h51(E)	8	#5	22'-7"	—
h52(E)	4	#5	10'-6"	—
p50(E)	20	#7	31'-0"	—
p51(E)	4	#5	24'-5"	—
s50(E)	48	#6	14'-4"	□
s51(E)	14	#5	4'-4"	└┘
sp50(E)	7	#4	2'-0"	WWW
u50(E)	8	#6	11'-10"	└┘
u51(E)	26	#5	5'-0"	└┘
v50(E)	134	#8	6'-8"	—
v51(E)	8	#5	8'-10"	—
v52(E)	18	#5	12'-10"	—
Structure Excavation	Cu. Yd.	291.5		
Concrete Structures	Cu. Yd.	33.4		
Reinforcement Bars, Epoxy Coated	Pounds	6,460		
Furnishing Steel Piles HP 14x89	Foot	240		
Driving Piles	Foot	240		
Test Pile Steel HP 14x89	Each	1		
Pile Shoes	Each	7		

\* Length is height of spiral

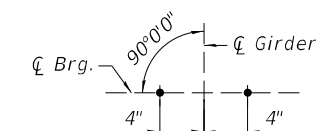

**ANCHOR BOLT LAYOUT**



USER NAME =	DESIGNED - MK	REVISED -
	CHECKED - DD	REVISED -
PLOT SCALE =	DRAWN - MK	REVISED -
PLOT DATE =	CHECKED - DD	REVISED -

**STATE OF ILLINOIS**  
**DEPARTMENT OF TRANSPORTATION**

**ABUTMENT DETAILS**  
**STRUCTURE NO. 099-8324**

SHEET S-25 OF S-31 SHEETS

F.A.I. RTE.	SECTION	COUNTY	TOTAL SHEETS	SHEET NO.
80	FAI 80 21 STRUCTURE 9	WILL	130	82
			CONTRACT NO. 62R30	
		ILLINOIS	FED. AID PROJECT	

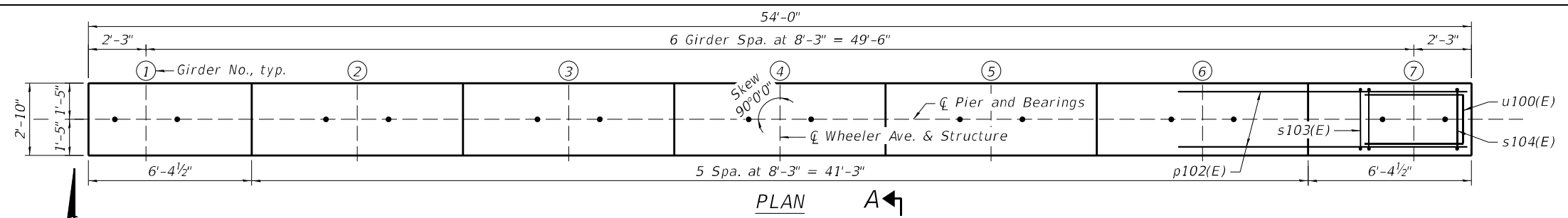
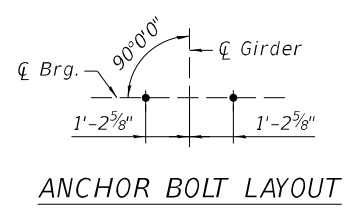

**MIN. BAR LAP**  
 (Unless Noted Otherwise)  
 #5 bar = 3'-7"  
 #8 bar = 5'-1"  
 #10 bar = 11'-6"

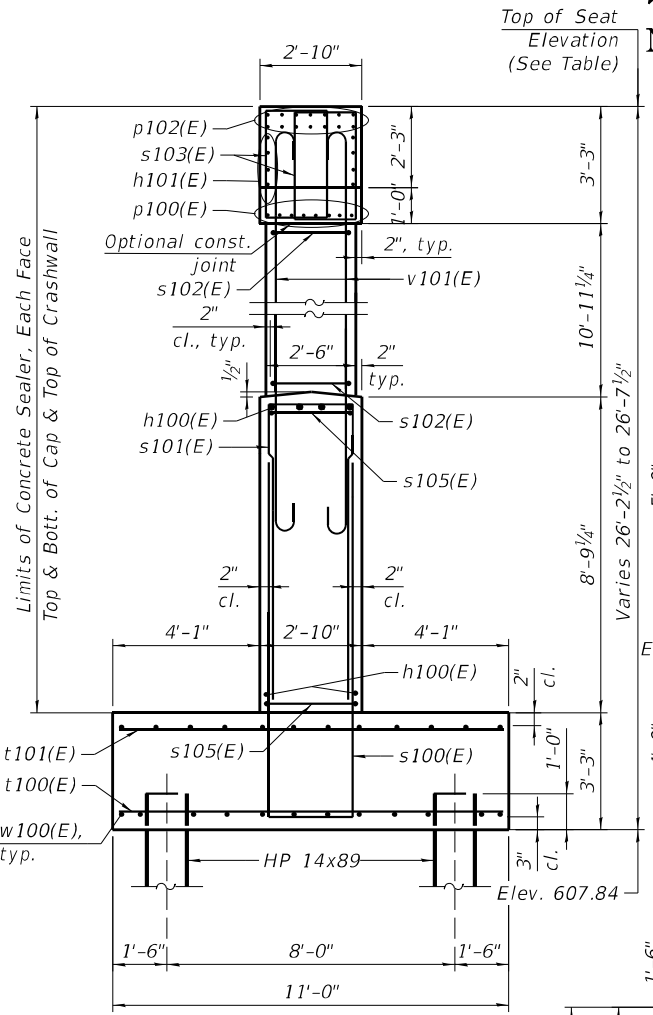

**END VIEW**

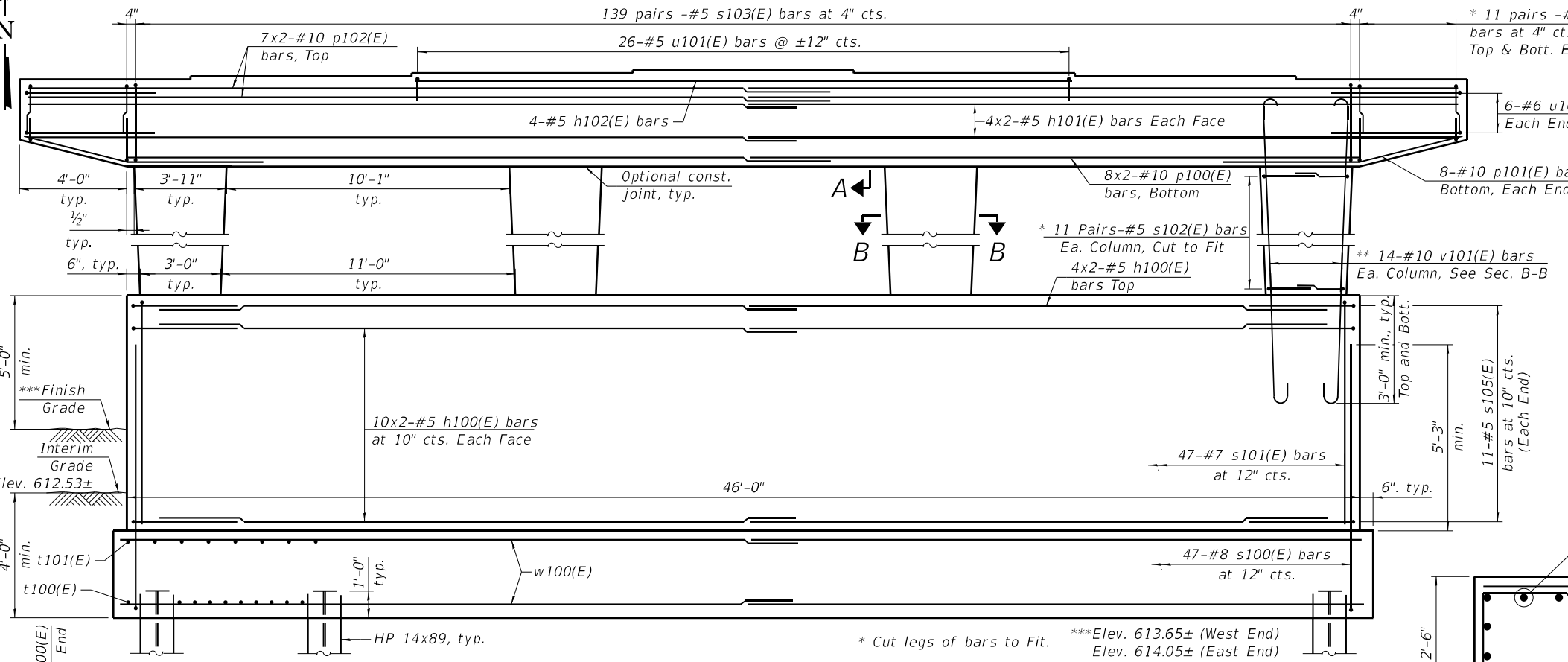

**ELEVATION**  
(Looking North)

**TOP OF SEAT ELEVATIONS**

Gdr. No	Seat Elev.
1	634.05
2	634.22
3	634.34
4	634.46
5	634.34
6	634.22
7	634.05

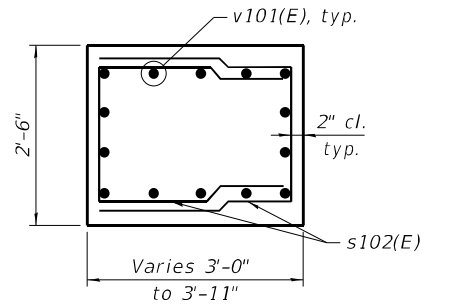

**SECTION B-B**

**PILE DATA**

Type: HP 14x89 w/ Pile Shoes  
 Nominal Required Bearing: 705 kips  
 Factored Resistance Available: 388 kips  
 Est. Length: 19 ft.  
 No. Production Piles: 15  
 No. Test Piles: 1

**NOTES:**

- See Sheet S-27 for Bar List & Bill of Material.
- Space reinforcement in cap to miss anchor bolts.
- Pour steps monolithically with cap.
- For details of piles, see sheet S-28.
- For Anchor Bolt Details see sheet S-23.

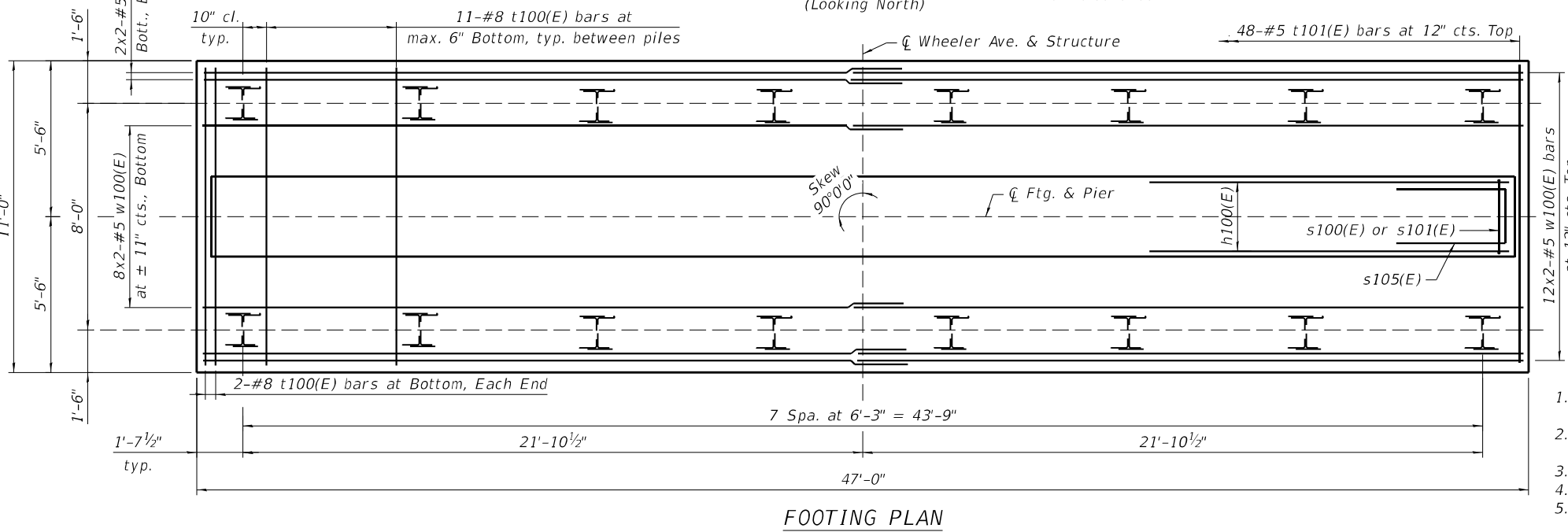

**FOOTING PLAN**

MODEL: Sheet  
 FILE NAME: pw://transsystems-pw.bentley.com/TRANSSYSTEMS-PW1-HOSTED/Projects/2018/CH401/40118002202-TransSystems/CAD/62R30/Sheets/S-31-Structural/099-8324-CR-03-026-Pier.dgn  
 9/28/2022 11:03:01 AM



USER NAME =	DESIGNED - MK	REVISED -
PLOT SCALE =	CHECKED - DD	REVISED -
PLOT DATE =	DRAWN - MK	REVISED -
	CHECKED - DD	REVISED -

**STATE OF ILLINOIS**  
**DEPARTMENT OF TRANSPORTATION**

**PIER PLAN & ELEVATION**  
**STRUCTURE NO. 099-8324**

SHEET S-26 OF S-31 SHEETS

FAI RTE.	SECTION	COUNTY	TOTAL SHEETS	SHEET NO.
80	FAI 80 21 STRUCTURE 9	WILL	130	83

CONTRACT NO. 62R30  
 ILLINOIS FED. AID PROJECT

MODEL: Sheet  
 FILE NAME: pw://transystems-pw.bentley.com/TRANSSYSTEMS/Projects\_2018/CH401/401180022/02-TransSystems/CAD/62R30/Sheets/2-Structural/099-8324-CR-03-027-Pier\_1.dgn

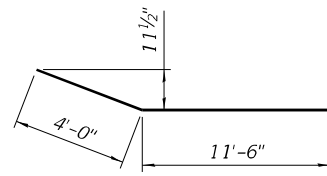

BAR p101(E)

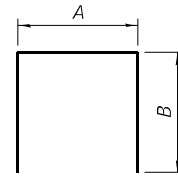

A & B DIMENSIONS

Bar	A	B
s100(E)	2'-6"	8'-3"
s101(E)	2'-6"	8'-5"
s102(E)	2'-2"	3'-5"
s104(E)	2'-6"	2'-11"
s105(E)	2'-6"	3'-7"

BARS s100(E), s101(E), s102(E), s104(E) & s105(E)

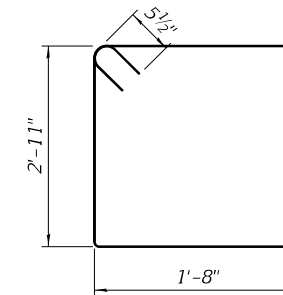

BAR s103(E)

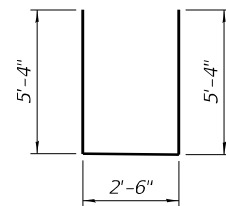

BAR u100(E)

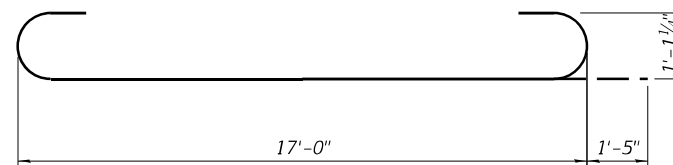

BAR v101(E)

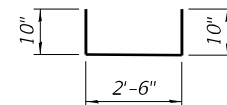

BAR u101(E)

**BILL OF MATERIAL**

Bar	No.	Size	Length	Shape
h100(E)	48	#5	24'-8"	—
h101(E)	16	#5	28'-8"	—
h102(E)	4	#5	24'-5"	—
p100(E)	16	#10	28'-9"	—
p101(E)	16	#10	15'-6"	—
p102(E)	28	#10	32'-7"	—
s100(E)	47	#8	19'-0"	⊏
s101(E)	47	#7	19'-4"	⊏
s102(E)	88	#5	9'-0"	⊏
s103(E)	278	#5	10'-1"	⊏
s104(E)	88	#5	8'-4"	⊏
s105(E)	22	#5	9'-8"	⊏
t100(E)	81	#8	10'-8"	—
t101(E)	48	#5	10'-8"	—
u100(E)	12	#6	13'-2"	⊏
u101(E)	26	#5	4'-2"	⊏
v101(E)	56	#10	19'-10"	⊏
w100(E)	48	#5	25'-2"	—
Structure Excavation		Cu. Yd.	132.9	
Concrete Structures		Cu. Yd.	137.7	
Reinforcement Bars, Epoxy Coated		Pound	27,000	
Concrete Sealer		Sq. Ft.	2,110	
Furnishing Steel Piles HP 14X89		Foot	285	
Driving Piles		Foot	285	
Test Pile Steel HP 14X89		Each	1	
Pile Shoes		Each	16	



USER NAME =	DESIGNED - MK	REVISED -
	CHECKED - DD	REVISED -
PLOT SCALE =	DRAWN - MK	REVISED -
PLOT DATE =	CHECKED - DD	REVISED -

STATE OF ILLINOIS  
 DEPARTMENT OF TRANSPORTATION

PIER DETAILS  
 STRUCTURE NO. 099-8324

SHEET S-27 OF S-31 SHEETS

F.A.I. RTE.	SECTION	COUNTY	TOTAL SHEETS	SHEET NO.
80	FAI 80 21 STRUCTURE 9	WILL	130	84
			CONTRACT NO. 62R30	
		ILLINOIS FED. AID PROJECT		

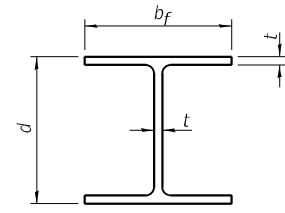

**STEEL PILE TABLE**

Designation	Depth d	Flange width b <sub>f</sub>	Web and Flange thickness t	Encasement diameter A
HP 14x117	14 1/4"	14 7/8"	1 3/16"	30"
x102	14"	14 3/4"	1 1/16"	30"
x89	13 7/8"	14 3/4"	5/8"	30"
x73	13 5/8"	14 5/8"	1/2"	30"
HP 12x84	12 1/4"	12 1/4"	1 1/16"	24"
x74	12 1/8"	12 1/4"	5/8"	24"
x63	12"	12 1/8"	1/2"	24"
x53	11 3/4"	12"	7/16"	24"
HP 10x57	10"	10 1/4"	9/16"	24"
x42	9 3/4"	10 1/4"	7/16"	24"
HP 8x36	8"	8 1/8"	7/16"	18"

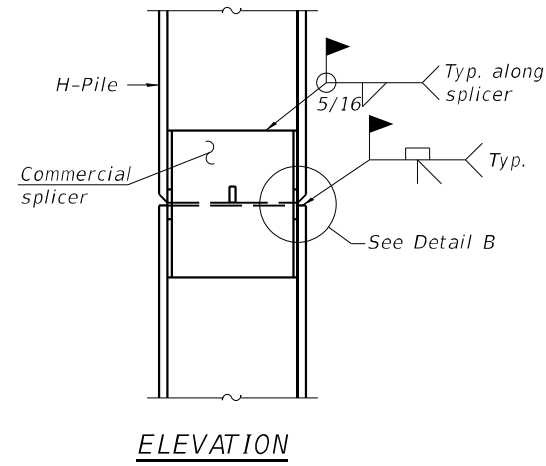

**ELEVATION**

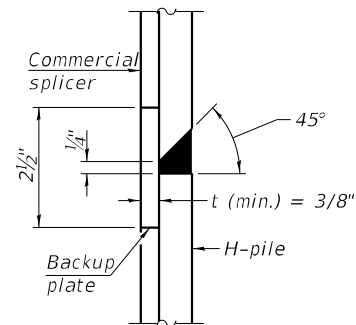

**DETAIL "B"**

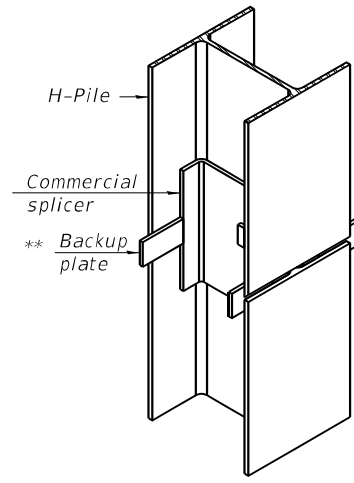

**ISOMETRIC VIEW**

**WELDED COMMERCIAL SPLICE**

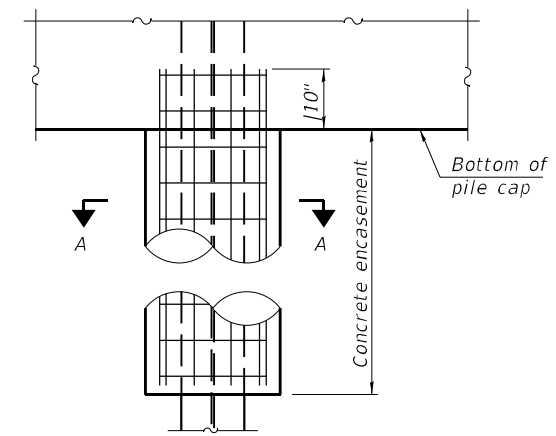

**ELEVATION**

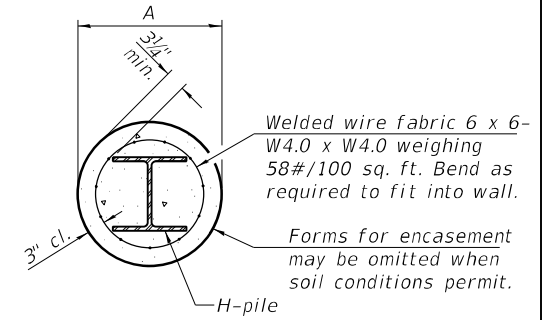

**SECTION A-A**

**INDIVIDUAL PILE CONCRETE ENCASUREMENT**  
(when specified)

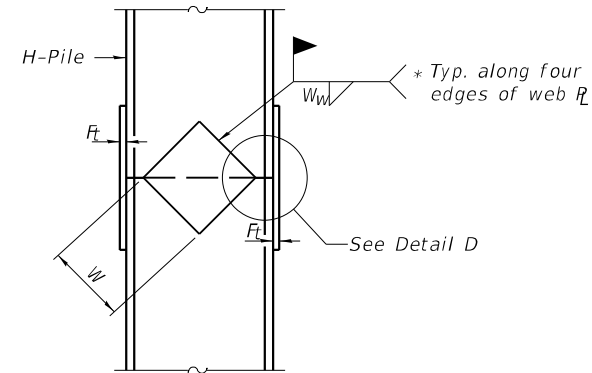

**ELEVATION**

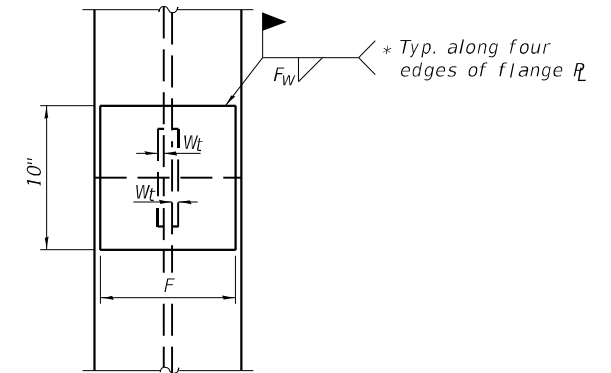

**END VIEW**

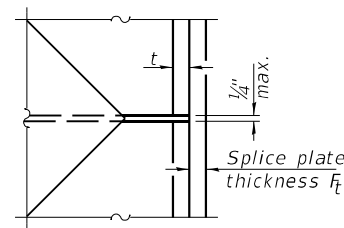

**DETAIL D**

**WELDED PLATE FIELD SPLICE**

Designation	F	F <sub>t</sub>	F <sub>w</sub>	W	W <sub>t</sub>	W <sub>w</sub>
HP 14x117	12 1/2"	1"	7/8"	7 3/4"	5/8"	1/2"
x102	12 1/2"	7/8"	3/4"	7 3/4"	5/8"	1/2"
x89	12 1/2"	3/4"	1 1/16"	7 3/4"	5/8"	1/2"
x73	12 1/2"	5/8"	9/16"	7 3/4"	5/8"	1/2"
HP 12x84	10"	7/8"	1 1/16"	6 1/2"	5/8"	1/2"
x74	10"	7/8"	1 1/16"	6 1/2"	5/8"	1/2"
x63	10"	5/8"	1/2"	6 1/2"	1/2"	3/8"
x53	10"	5/8"	1/2"	6 1/2"	1/2"	3/8"
HP 10x57	8"	3/4"	9/16"	5 1/4"	1/2"	3/8"
x42	8"	5/8"	9/16"	5 1/4"	1/2"	3/8"
HP 8x36	7"	5/8"	7/16"	4 1/4"	1/2"	3/8"

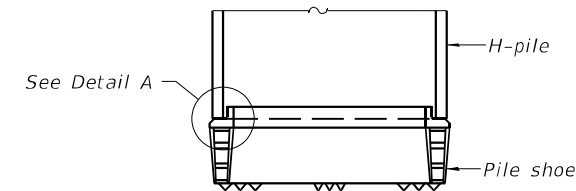

**ELEVATION**

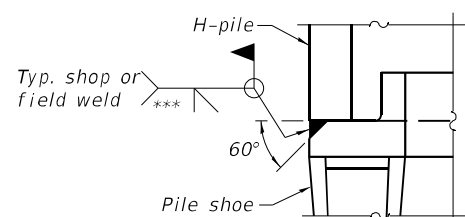

**DETAIL A**

**H-PILE SHOE ATTACHMENT**

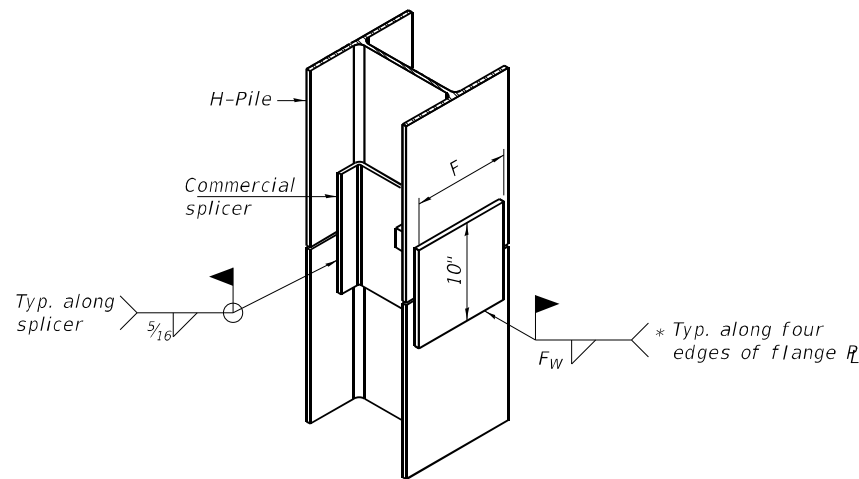

**ISOMETRIC VIEW**

**WELDED COMMERCIAL SPLICE ALTERNATE**

- \* Interrupt welds 1/4" from end of web and/or each flange.
- \*\* Remove portions of backup plates that extend outside the flanges.
- \*\*\* Weld size per pile shoe manufacturer (5/16" min.).

**NOTES:**  
The steel H-piles shall be according to AASHTO M270 Grade 50.

F-HP 1-1-2020



USER NAME =	DESIGNED - MK	REVISED -
PLOT SCALE =	CHECKED - DD	REVISED -
PLOT DATE =	DRAWN - MK	REVISED -
	CHECKED - DD	REVISED -

**STATE OF ILLINOIS  
DEPARTMENT OF TRANSPORTATION**

**HP PILE DETAILS  
STRUCTURE NO. 099-8324**

SHEET S-28 OF S-31 SHEETS

F.A.I. RTE.	SECTION	COUNTY	TOTAL SHEETS	SHEET NO.
80	FAI 80 21 STRUCTURE 9	WILL	130	85
CONTRACT NO. 62R30				
ILLINOIS FED. AID PROJECT				

MODEL: Sheet  
FILE NAME: pw://transystems-pw.bentley.com/TRANSYS/SCORP-PW1-HOSTED/Projects\_2018/CH401/40118002202-TransSystems/CAD/62R30/5heets/2-Structural/099-8324-CR-03-029-Boring\_1.dgn

**Wang Engineering**  
wangeng@wangeng.com  
1145 N Main Street  
Lombard, IL 60148  
Telephone: (630) 953-9928  
Fax: (630) 953-9938

**BORING LOG WA-BSB-01**  
WEI Job No.: 7901-15-01  
Client: **TranSystems Corporation**  
Project: **80 Reconstruction (Houbolt Road to Center Street)**  
Location: **Will County, Illinois**

Datum: NAVD 88  
Elevation: 637.53 ft  
North: 1764033.78 ft  
East: 1046708.69 ft  
Station: 21+47.90  
Offset: 32.52 LT

Page 1 of 2

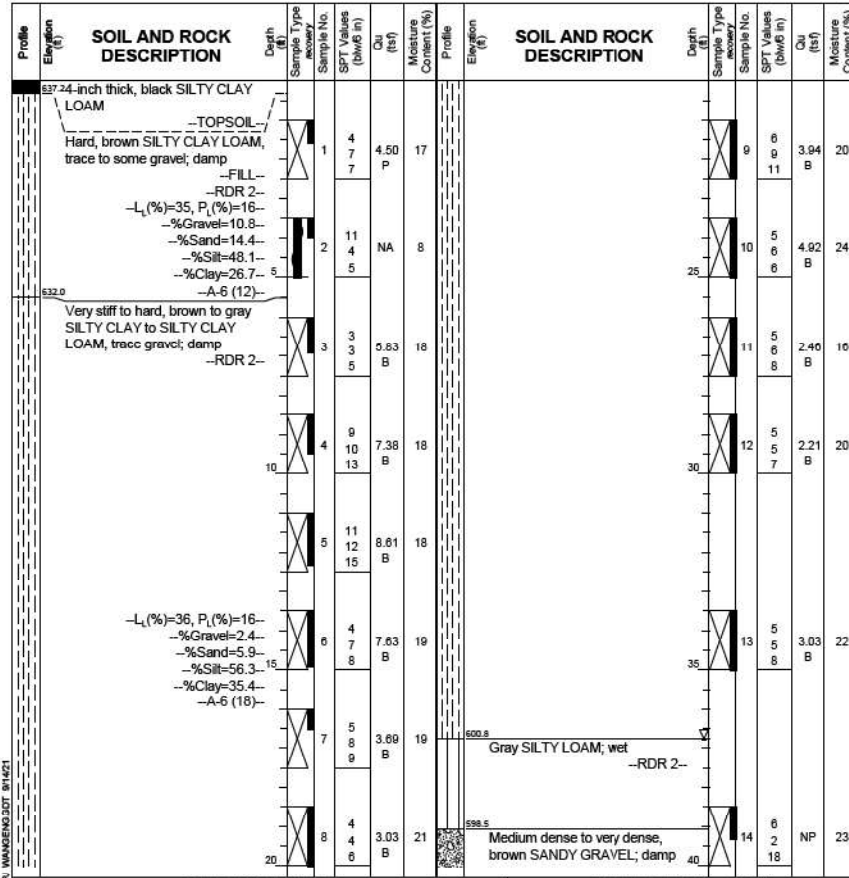

**GENERAL NOTES**  
Begin Drilling: 03-23-2021  
Complete Drilling: 03-23-2021  
Drilling Contractor: Wang Testing Services, Drill Rig: 20CME55T(81%)  
Driller: RR&J, Logger: I. Nenn, Checked by: C. Marin  
Drilling Method: 2.25" IDA HSA; boring backfilled upon completion

**WATER LEVEL DATA**  
While Drilling: 36.75 ft  
At Completion of Drilling: NA  
Time After Drilling: NA  
Depth to Water: NA

The stratification lines represent the approximate boundary between soil types; the actual transition may be gradual.

**Wang Engineering**  
wangeng@wangeng.com  
1145 N Main Street  
Lombard, IL 60148  
Telephone: (630) 953-9928  
Fax: (630) 953-9938

**BORING LOG WA-BSB-01**  
WEI Job No.: 7901-15-01  
Client: **TranSystems Corporation**  
Project: **80 Reconstruction (Houbolt Road to Center Street)**  
Location: **Will County, Illinois**

Datum: NAVD 88  
Elevation: 637.53 ft  
North: 1764033.78 ft  
East: 1046708.69 ft  
Station: 21+47.90  
Offset: 32.52 LT

Page 2 of 2

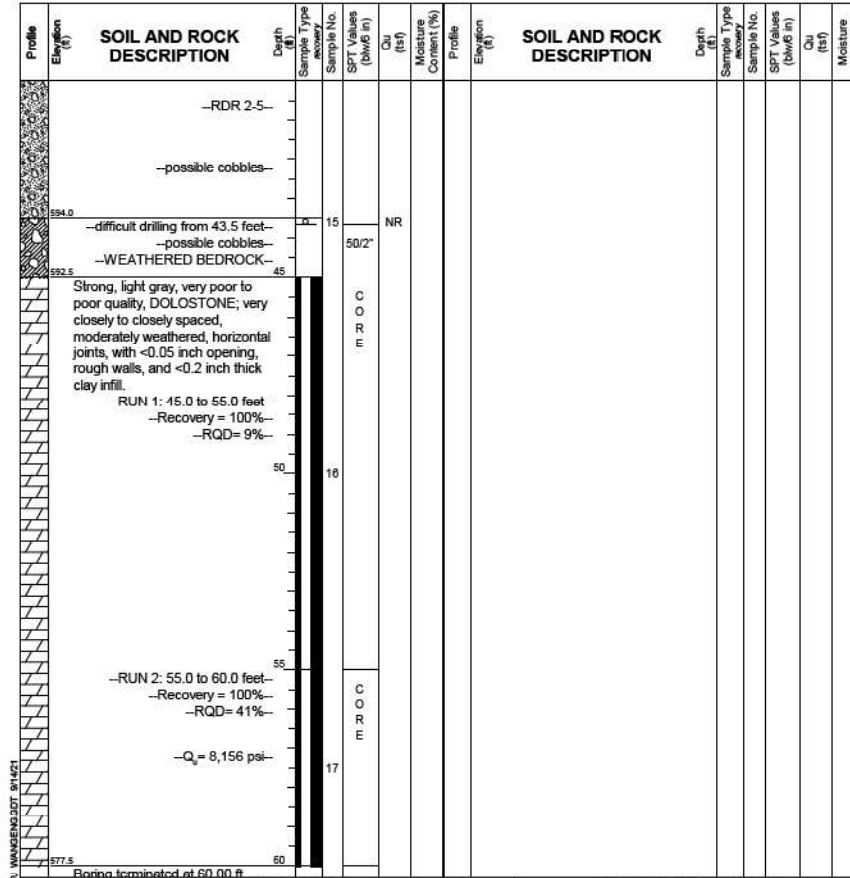

**GENERAL NOTES**  
Begin Drilling: 03-23-2021  
Complete Drilling: 03-23-2021  
Drilling Contractor: Wang Testing Services, Drill Rig: 20CME55T(81%)  
Driller: RR&J, Logger: I. Nenn, Checked by: C. Marin  
Drilling Method: 2.25" IDA HSA; boring backfilled upon completion

**WATER LEVEL DATA**  
While Drilling: 36.75 ft  
At Completion of Drilling: NA  
Time After Drilling: NA  
Depth to Water: NA

The stratification lines represent the approximate boundary between soil types; the actual transition may be gradual.

**Wang Engineering**  
wangeng@wangeng.com  
1145 N Main Street  
Lombard, IL 60148  
Telephone: (630) 953-9928  
Fax: (630) 953-9938

**BORING LOG WA-BSB-02**  
WEI Job No.: 7901-15-01  
Client: **TranSystems Corporation**  
Project: **80 Reconstruction (Houbolt Road to Center Street)**  
Location: **Will County, Illinois**

Datum: NAVD 88  
Elevation: 635.74 ft  
North: 1764635.42 ft  
East: 1046768.31 ft  
Station: 18+47.88  
Offset: 18.04 RT

Page 1 of 2

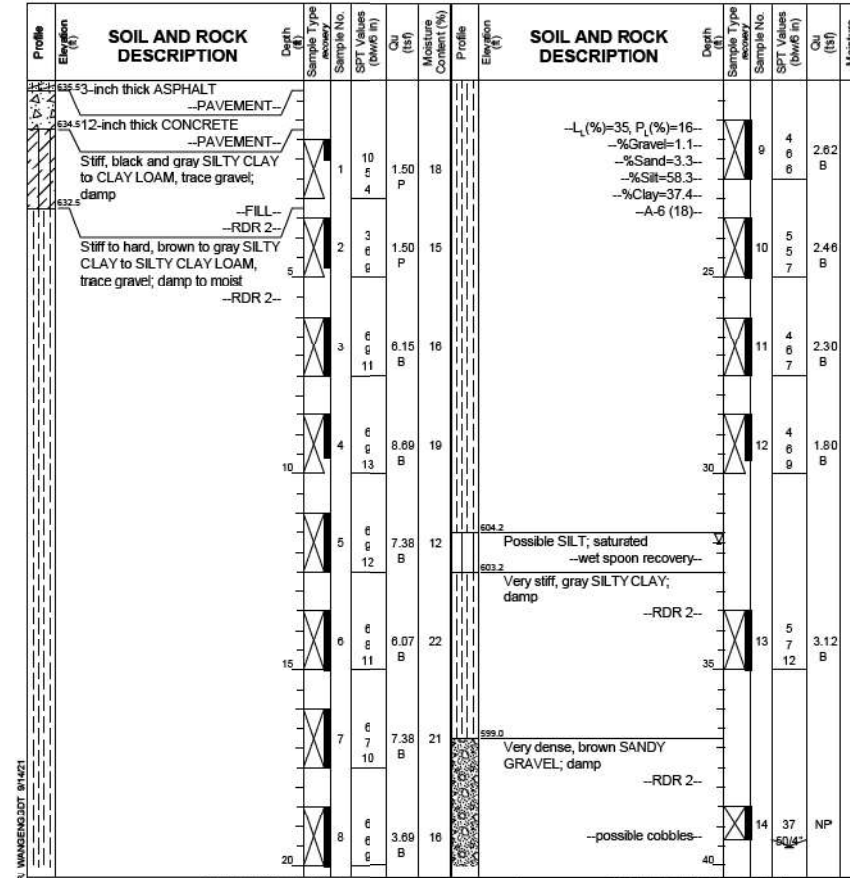

**GENERAL NOTES**  
Begin Drilling: 03-22-2021  
Complete Drilling: 03-22-2021  
Drilling Contractor: Wang Testing Services, Drill Rig: 20CME55T(81%)  
Driller: RR&J, Logger: I. Nenn, Checked by: C. Marin  
Drilling Method: 3.25" IDA HSA; boring backfilled upon completion

**WATER LEVEL DATA**  
While Drilling: 31.75 ft  
At Completion of Drilling: NA  
Time After Drilling: NA  
Depth to Water: NA

The stratification lines represent the approximate boundary between soil types; the actual transition may be gradual.



USER NAME =	DESIGNED - MK	REVISED -
PLOT SCALE =	CHECKED - DD	REVISED -
PLOT DATE =	DRAWN - MK	REVISED -
	CHECKED - DD	REVISED -

**STATE OF ILLINOIS  
DEPARTMENT OF TRANSPORTATION**

**SOIL BORING LOG I  
STRUCTURE NO. 099-8324**

SHEET S-29 OF S-31 SHEETS

F.A.I. RTE.	SECTION	COUNTY	TOTAL SHEETS	SHEET NO.
80	FAI 80 21 STRUCTURE 9	WILL	130	86
CONTRACT NO. 62R30				
ILLINOIS FED. AID PROJECT				

MODEL: Sheet  
FILE NAME: pw://transystems-pw.bentley.com/Projects/2018/CH401/40118002202-Transystems/CAD/62R30/5heets/2-Structural/099-8324-CR-03-030-Boring\_IL.dgn  
9/28/2022 11:04:26 AM

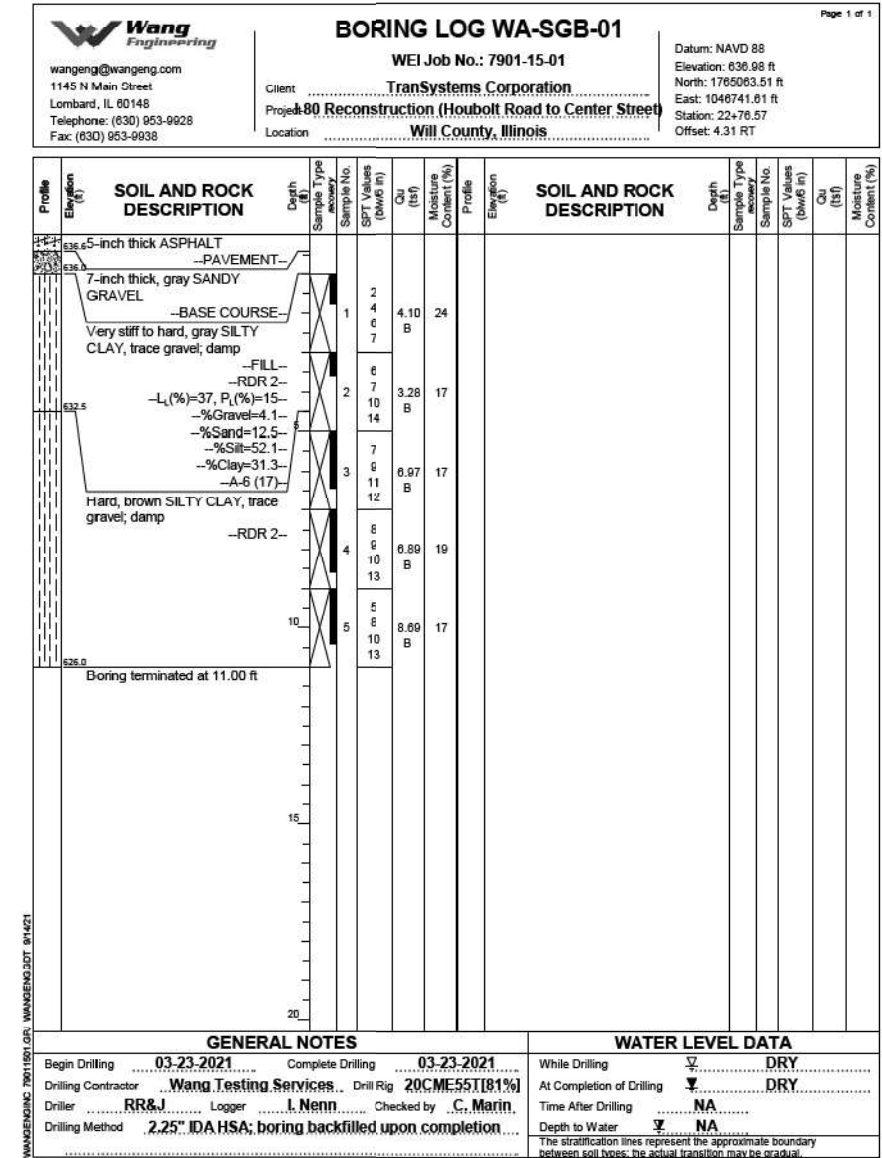
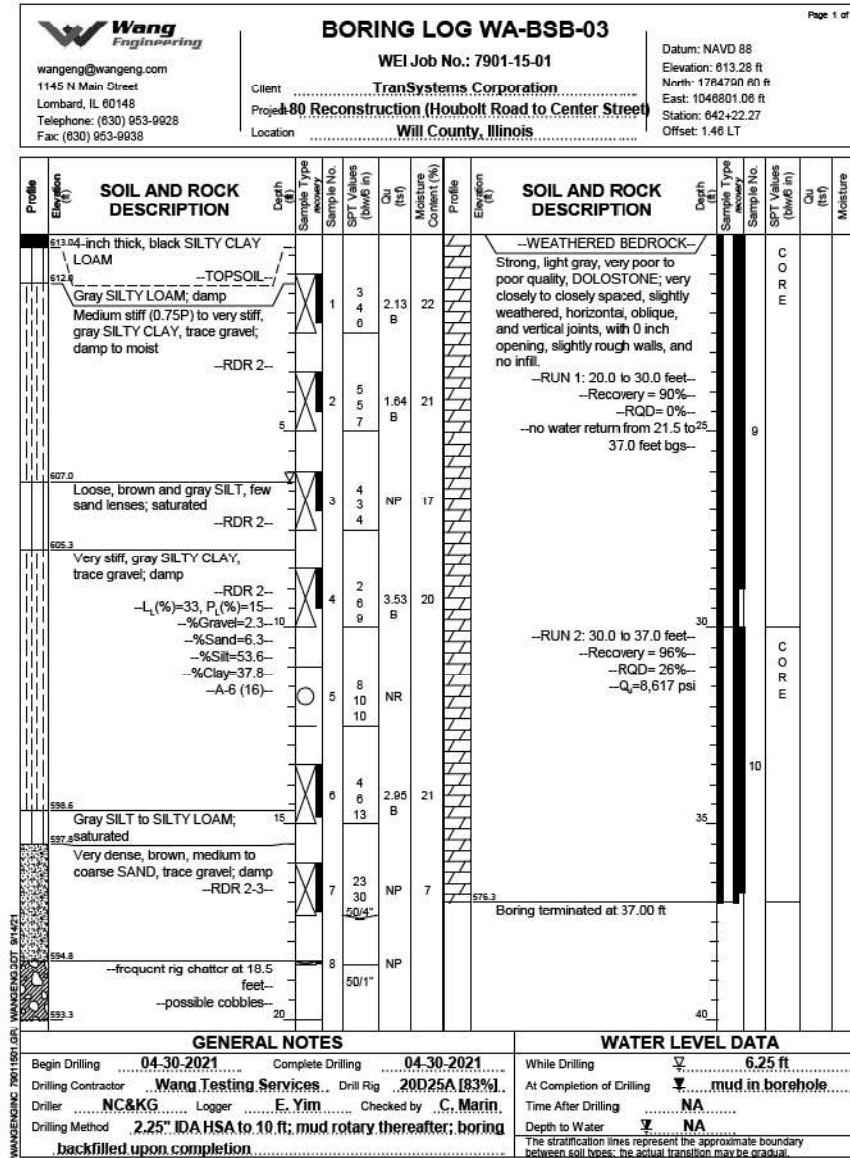
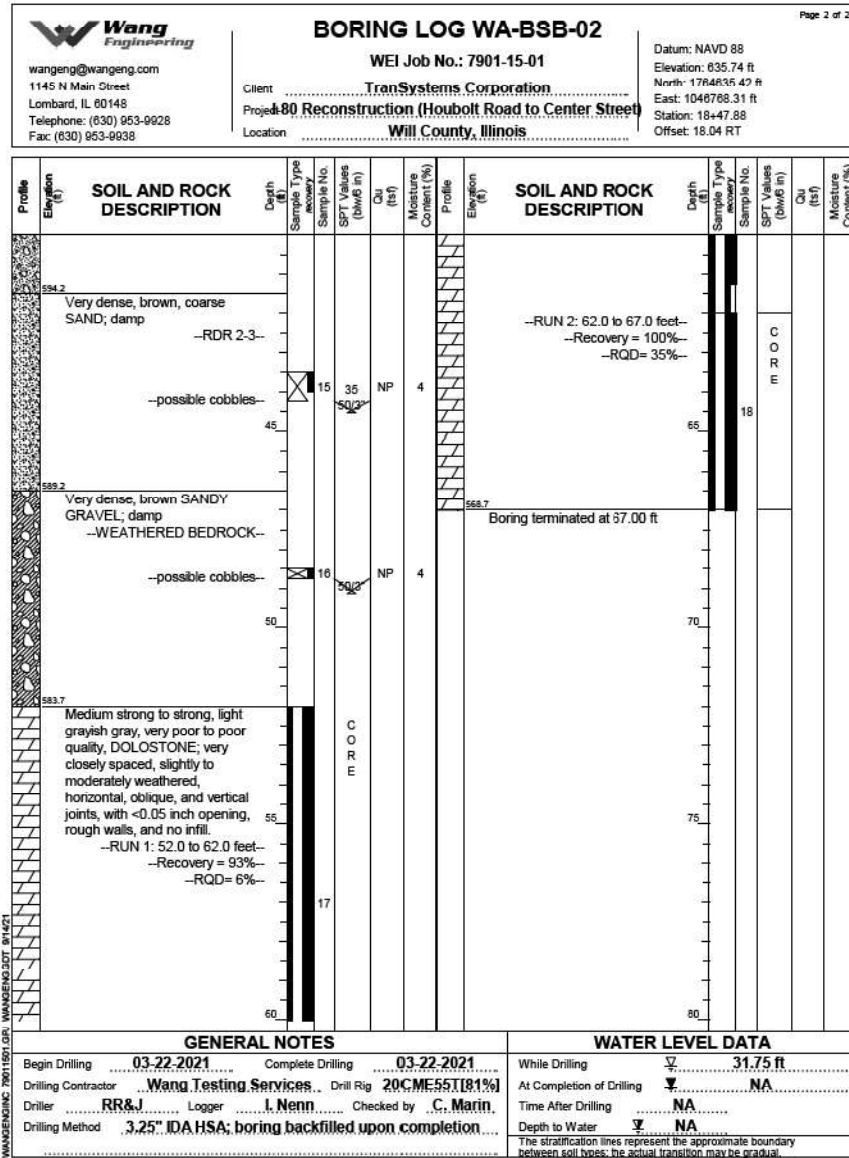

Note:  
Boring Log WA-BSB-03  
1-80 Sta.: 642+22.27 Offset: 1.46 LT =  
Wheeler Ave. Sta.: 20+01.99 Offset: 55.48 RT



USER NAME =	DESIGNED - MK	REVISED -
PLOT SCALE =	CHECKED - DD	REVISED -
PLOT DATE =	DRAWN - MK	REVISED -
	CHECKED - DD	REVISED -

**STATE OF ILLINOIS  
DEPARTMENT OF TRANSPORTATION**

**SOIL BORING LOG II  
STRUCTURE NO. 099-8324**

SHEET S-30 OF S-31 SHEETS

F.A.I. RTE.	SECTION	COUNTY	TOTAL SHEETS	SHEET NO.
80	FAI 80 21 STRUCTURE 9	WILL	130	87
CONTRACT NO. 62R30				
ILLINOIS   FED. AID PROJECT				

**Wang Engineering**  
 wangeng@wangeng.com  
 1145 N Main Street  
 Lombard, IL 60148  
 Telephone: (630) 953-9928  
 Fax: (630) 953-9938

**BORING LOG WA-SGB-02**  
 WEI Job No.: 7901-15-01  
 Client: TranSystems Corporation  
 Project: 80 Reconstruction (Houbolt Road to Center Street)  
 Location: Will County, Illinois

Datum: NAVD 88  
 Elevation: 634.01 ft  
 North: 1764465.37 ft  
 East: 1046733.89 ft  
 Station: 17+06.03  
 Offset: 20.61 LT

Page 1 of 1

Profile Elevation (ft)	SOIL AND ROCK DESCRIPTION	Depth (ft)	Sample No.	SPT Values (blows/in)	Cu (tsf)	Moisture Content (%)	Profile Elevation (ft)	SOIL AND ROCK DESCRIPTION	Depth (ft)	Sample No.	SPT Values (blows/in)	Cu (tsf)	Moisture Content (%)
633.43	3-inch thick ASPHALT --PAVEMENT--												
633.3	7-inch thick CONCRETE --PAVEMENT--												
631	2-inch thick, gray SANDY GRAVEL; damp --BASE COURSE--	1	2	1.48	28								
	Stiff, brown CLAY, trace to few gravel; damp	2	3	5.33	17								
	--FILL--												
	--RDR 2--												
	--L <sub>c</sub> (%)=46, P <sub>c</sub> (%)=15--												
	--%Gravel=8.8--												
	--%Sand=19.6--												
	--%Silt=41.8--												
	--%Clay=29.7--												
	--A-7-6 (20)--												
	Hard, brown SILTY CLAY, trace gravel; damp	4	7	6.07	16								
	--RDR 2--												
		10	11	6.56	16								
			14	4.92	16								
			14										
	Boring terminated at 11.00 ft												

GENERAL NOTES		WATER LEVEL DATA	
Begin Drilling	03-22-2021	Complete Drilling	03-22-2021
Drilling Contractor	Wang Testing Services	Drill Rig	20CME55T181%
Driller	RR&J	Logger	I. Nenn
Checked by	C. Marin	Time After Drilling	NA
Drilling Method	2.25" IDA HSA; boring backfilled upon completion	Depth to Water	NA
The stratification lines represent the approximate boundary between soil types; the actual transition may be gradual.			

MODEL: Sheet  
 FILE NAME: pw://transystems-pw.bentley.com/TRANSSYSTEMS/PW1-HOSTED/DOCUMENTS/PROJECTS\_2018/CH401/401180022/02-TransSystems/CAD/62R30/SHEETS/2-Structural/099-8324/0998324-CR-03-03-1-Boring\_III.dgn  
 WANGENGINE 79011501.GRD WANGENGINE.DOT 6/14/21



USER NAME =	DESIGNED - MK	REVISED -
PLOT SCALE =	CHECKED - DD	REVISED -
PLOT DATE =	DRAWN - MK	REVISED -
	CHECKED - DD	REVISED -

**STATE OF ILLINOIS  
 DEPARTMENT OF TRANSPORTATION**

**SOIL BORING LOG III  
 STRUCTURE NO. 099-8324**

SHEET S-31 OF S-31 SHEETS

F.A.I. RTE.	SECTION	COUNTY	TOTAL SHEETS	SHEET NO.
80	FAI 80 21 STRUCTURE 9	WILL	130	88
CONTRACT NO. 62R30				
		ILLINOIS	FED. AID PROJECT	



# STATE OF ILLINOIS DEPARTMENT OF PUBLIC WORKS AND BUILDINGS DIVISION OF HIGHWAYS PLANS FOR PROPOSED FEDERAL AID INTERSTATE HIGHWAY

FEDERAL AID PROJECT NO.	SEC.	COUNTY	TOTAL SHEETS	SHEET NO.
FAI-80	99-3	WILL	130	1
P-91-107-00 (99-3) 1-10 (21) P-91-257-00 (10) 1-10 (9) P-91-258-00 (1-D-2)				

INDEX TO SHEETS

1	TITLE SHEET
2-9	TYPICAL SECTIONS
10	GENERAL NOTES
10A-10G	CRITICAL PATH SCHEDULE
11-17 & 17A	SCHEDULES OF QUANTITIES
18, 19	SUMMARY OF QUANTITIES
19	MAINTENANCE OF TRAFFIC
20	GENERAL PLAN
21-25	PLANS
25A-25D	ACCESS ROAD "B" DETAILS
26	GENERAL PLAN CONTOURS
27	SUPERELEVATION TABLES
28-29	PROFILES
40	GENERAL PLAN - ALIGNMENT
41-45	ALIGNMENT PLANS
46	RAMP TERMINAL DETAILS
47-53	JOINT LAYOUT AND PAVEMENT ELEVATIONS
54	GENERAL PLAN - DRAINAGE
55-59	DRAINAGE PLANS
60-64	EXISTING TOPOGRAPHY AND REMOVAL PLANS
65-72	EXISTING UTILITIES
73	GRADING PLAN
74	APPROACH SLAB DETAIL - DES PLAINES RIVER BRIDGE
75-84	DETAILED BRIDGE PLANS - STRUCTURE NO. 1
85-96	DETAILED BRIDGE PLANS - STRUCTURE NO. 2
97-104	DETAILED BRIDGE PLANS - STRUCTURE NO. 3
105-113	DETAILED BRIDGE PLANS - STRUCTURE NO. 4
113-124	DETAILED BRIDGE PLANS - STRUCTURE NO. 5
125-134	DETAILED BRIDGE PLANS - STRUCTURE NO. 6
135-144	DETAILED BRIDGE PLANS - STRUCTURE NO. 7
145-152	DETAILED BRIDGE PLANS - STRUCTURE NO. 8
153-183	CROSS SECTIONS
183A-183J	CROSS SECTIONS - ACCESS ROAD B
184, a, b, c	STANDARDS 1258, 1527-2, 1538-3, 1683-2
185, a, b, c	STANDARDS 2102, 2213, 2214, 2217
186, a, b	STANDARDS 1686-2, 1687-3, 2219
187, a, b	STANDARDS 1766-4, 2115-1, 2135
188, a, b	STANDARDS 2130, 1886-2, 2189-1
189, a, b	STANDARDS 1914, 1971-3, 2215
190, a	STANDARDS 1909-6, 2220
191, a	STANDARDS 2136-4, 2222
192, a	STANDARDS 1970, 2113-1
193, a	STANDARDS 2051, 2122-1
194, a	STANDARDS 2150-2, 2153-4
195, a	STANDARDS 2168-1, 1744-1
196, a, b	STANDARDS 1526-2, 2134, 2179-1
197, a	STANDARDS 2208-1, 2209

SCALES  
 PLAN 1" = 80 FT.  
 PROFILE HOR. 1" = 80 FT.  
 PROFILE VERT. 1" = 8 FT.  
 CROSS-SECTIONS 1" = 10 FT.

**FAI. ROUTE 80 C-91-313-64 SECTION 99-3, 99-3(HB, HB-1, HB-2, HB-3)**  
**PROJECT I-80-4 (22) 133**  
**FA. ROUTE 61 C-91-388-64 SECTION 10, 10(HB, HB-1, HB-2)**  
**PROJECT U-184 (21)**  
**FA. ROUTE 8 C-91-343-64 SECTION I-D-2, I-D-2HB**  
**PROJECT U-10 (9)**  
**WILL COUNTY**

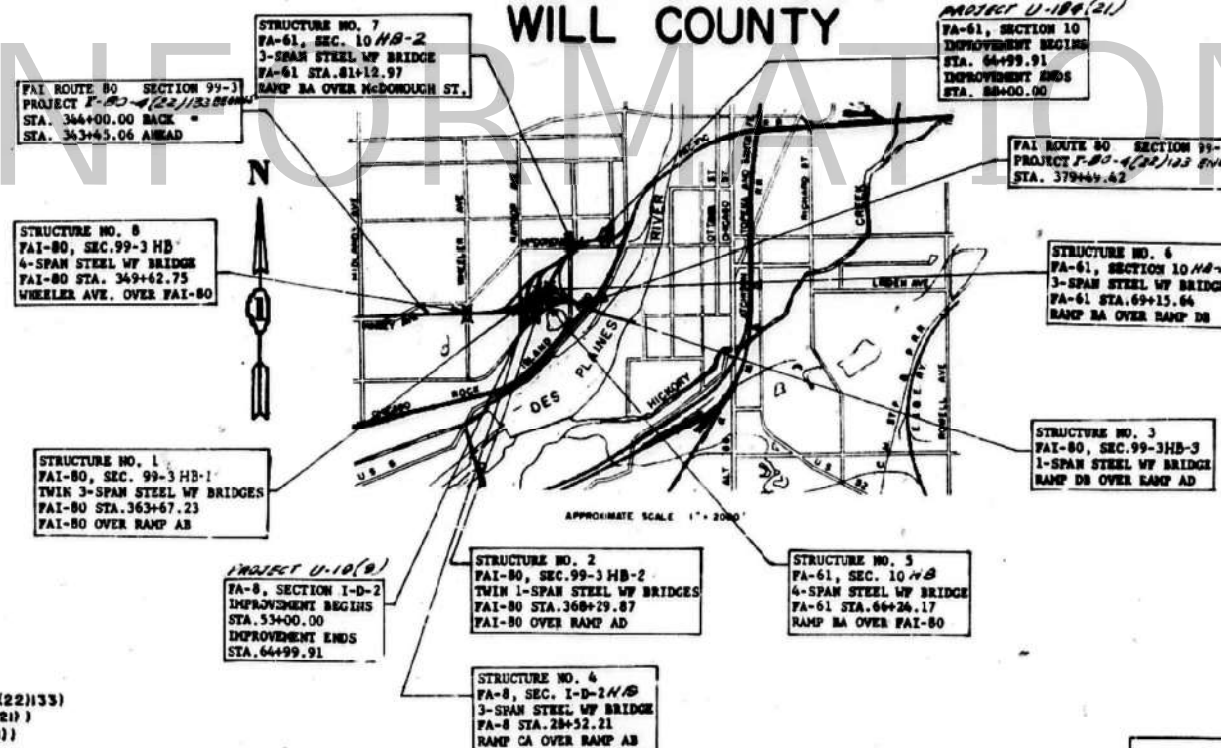

PROJECT LENGTH  
 FAI ROUTE 80 3,604.36 FT. = 0.683 MI. (I-80-4(22)133)  
 FA ROUTE 61 2,300.09 FT. = 0.436 MI. (U-184(21))  
 FA ROUTE 8 1,199.91 FT. = 0.227 MI. (U-10(9))

GROSS LENGTH  
 FAI ROUTE 80 3,604.36 FT. = 0.683 MI.  
 FA ROUTE 61 2,300.09 FT. = 0.436 MI.  
 FA ROUTE 8 1,199.91 FT. = 0.227 MI.

PLANS PREPARED AND RECOMMENDED BY  
**BLAUVELT ENGINEERING COMPANY**  
 CONSULTING ENGINEERS  
 CRYSTAL LAKE, ILL. - NEW YORK, N.Y. - WOODBURY N.J.

APPROVED  
 FOR STRUCTURAL ADVISORY PANEL

*W.S. [Signature]*  
 State Engineer

STATE OF ILLINOIS  
 DEPARTMENT OF PUBLIC WORKS AND BUILDINGS  
 DIVISION OF HIGHWAYS  
 RECEIVED October 27 1965  
*[Signature]*  
 October 19 1965  
*[Signature]*  
 October 12 1965  
*[Signature]*  
 October 19 1965  
*[Signature]*

DEPARTMENT OF COMMERCE  
 BUREAU OF PUBLIC ROADS

APPROVED \_\_\_\_\_

DIVISION ENGINEER \_\_\_\_\_ DATE \_\_\_\_\_

CONTRACT NO. 62R30

MODEL: Sheet  
 FILE NAME: pw://transys/pw/bentley.com:TRANSSYS/Projects\_2018/CH401/40118002202-Transys/CAD/62R30/Sheets/2-Structural/099-8324/0998324-CR-03-032-ExistingPlan\_1.dgn



USER NAME =	DESIGNED - MK	REVISED -
	CHECKED - DD	REVISED -
PLOT SCALE =	DRAWN - MK	REVISED -
PLOT DATE =	CHECKED - DD	REVISED -

STATE OF ILLINOIS  
DEPARTMENT OF TRANSPORTATION

EXISTING PLANS - I  
STRUCTURE NO. 099-0175

F.A.I. RTE.	SECTION	COUNTY	TOTAL SHEETS	SHEET NO.
80	FAI 80 21 STRUCTURE 9	WILL	130	89
CONTRACT NO. 62R30				
ILLINOIS FED. AID PROJECT				

STATE OF ILLINOIS  
DEPARTMENT OF PUBLIC WORKS & BUILDINGS  
DIVISION OF HIGHWAYS

ROUTE NO.	SECTION	COUNTY	TOTAL SHEETS	SHEET NO.	SHEET NO. 1
FAI 80	99-3HB	WILL	145	145	8 SHEETS

BM No 41 Elev 637.352 Sta 350+05  
Top of the letter "C" in the word  
"Open" on the fire hydrant at the  
S.E. corner of Kammerman and Wheeler  
Avenues.  
No Existing Structure

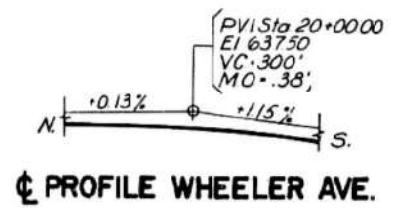

STATION 349+62.75  
BUILT 196 BY  
STATE OF ILLINOIS  
FAI RT. 80 SEC. 99-3HB  
FA PROJ. 1-80-4(22)  
LOADING HS 20  
See Standard 2113-1  
LETTERING FOR NAME PLATE

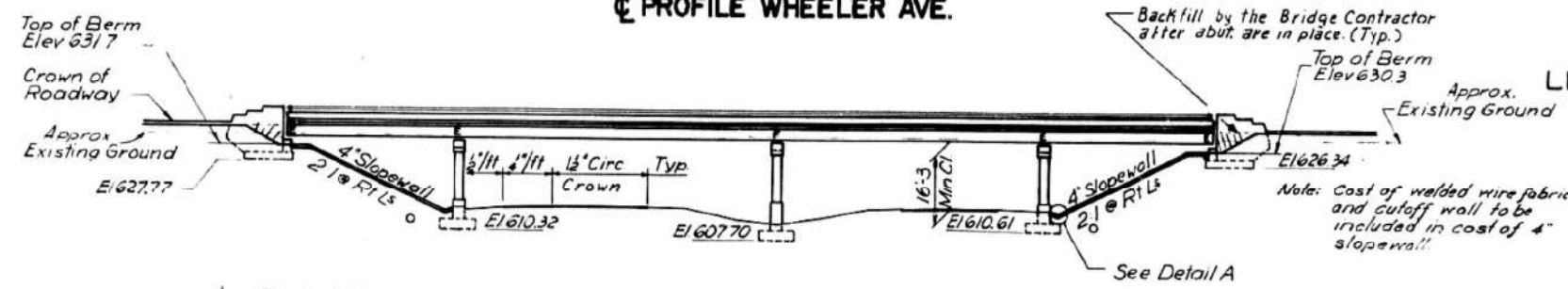

Design Stresses:  
Reinforced Concrete  
fc = 3500 PSI  
fs = 20,000 PSI  
n = 10  
fc = 4000 PSI (except footings)  
fc = 1,000 PSI (footings)  
Vc = 90 PSI (except footings)  
Vc = 75 PSI (footings)  
Structural Steel  
fs = 20,000 PSI  
Maximum Soil Pressure = 2 1/2 Tons/Sq Ft  
Loading = HS 20-44

**GENERAL NOTES**

STRUCTURAL STEEL SHALL CONFORM TO THE SPECIFICATIONS FOR STRUCTURAL STEEL, A.S.T.M. DESIGNATIONS A 36.

RIVETS SHALL BE 3/4" # WITH 13/16" # OPEN HOLES UNLESS NOTED.

CLASS X CONCRETE SHALL BE USED THROUGHOUT. COARSE AGGREGATE USED IN PARAPETS AND END POSTS SHALL BE FREE OF GHEFT, FLINT, LIMONITE, LIGNITE AND SOFT SANDSTONE.

THE CONCRETE FLOOR SLAB SHALL BE FINISHED IN ACCORDANCE WITH ARTICLE 51.19 OF THE STANDARD SPECIFICATIONS.

ALL WELDING SHALL COMPLY WITH THE REQUIREMENTS OF THE STANDARD SPECIFICATIONS FOR WELDED HIGHWAY AND RAILWAY BRIDGES, OF THE AMERICAN WELDING SOCIETY.

ALL ROCKERS, BOLSTERS, BEARING PLATES, LEAD PLATES, PINTLES, AND ANCHOR BOLTS SHALL BE FABRICATED AND SET IN ACCORDANCE WITH ARTICLE 51.15 OF THE STANDARD SPECIFICATIONS AND ARE INCLUDED IN QUANTITY OF STRUCTURAL STEEL.

ANCHOR BOLTS SHALL BE SET BEFORE CONNECTING DIAPHRAGMS OVER SUPPORT. SPACE REINFORCING TO MISS ANCHOR BOLTS.

EXPANSION GUARDS AND PLATES SHALL BE FABRICATED AND ERECTED IN ACCORDANCE WITH ARTICLE 51.13 (d) OF THE STANDARD SPECIFICATIONS AND ARE INCLUDED IN QUANTITY OF STRUCTURAL STEEL.

EXCEPT AS OTHERWISE PROVIDED, ALL STRUCTURAL STEEL SHALL RECEIVE ONE SHOP COAT OF RED LEAD PAINT AND TWO FIELD COATS OF ALUMINUM PAINT. SEE ARTICLES 55.1 TO 55.5 INCLUSIVE OF THE STANDARD SPECIFICATIONS.

ALL SURFACES OF EXPANSION GUARDS INACCESSIBLE AFTER ERECTION SHALL BE GIVEN TWO SHOP COATS OF RED LEAD PAINT. THE 3/4" # WELDED STUDS SHALL NOT BE PAINTED.

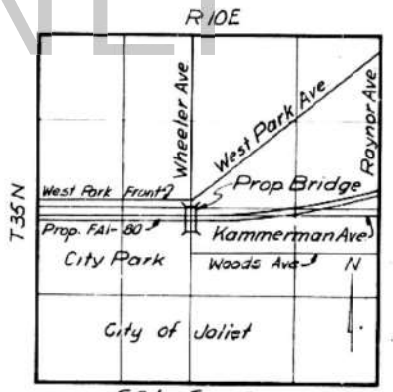
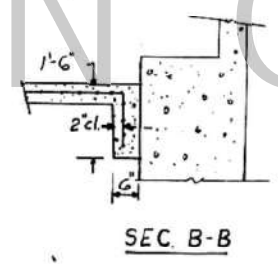
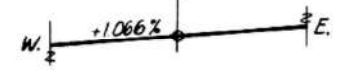
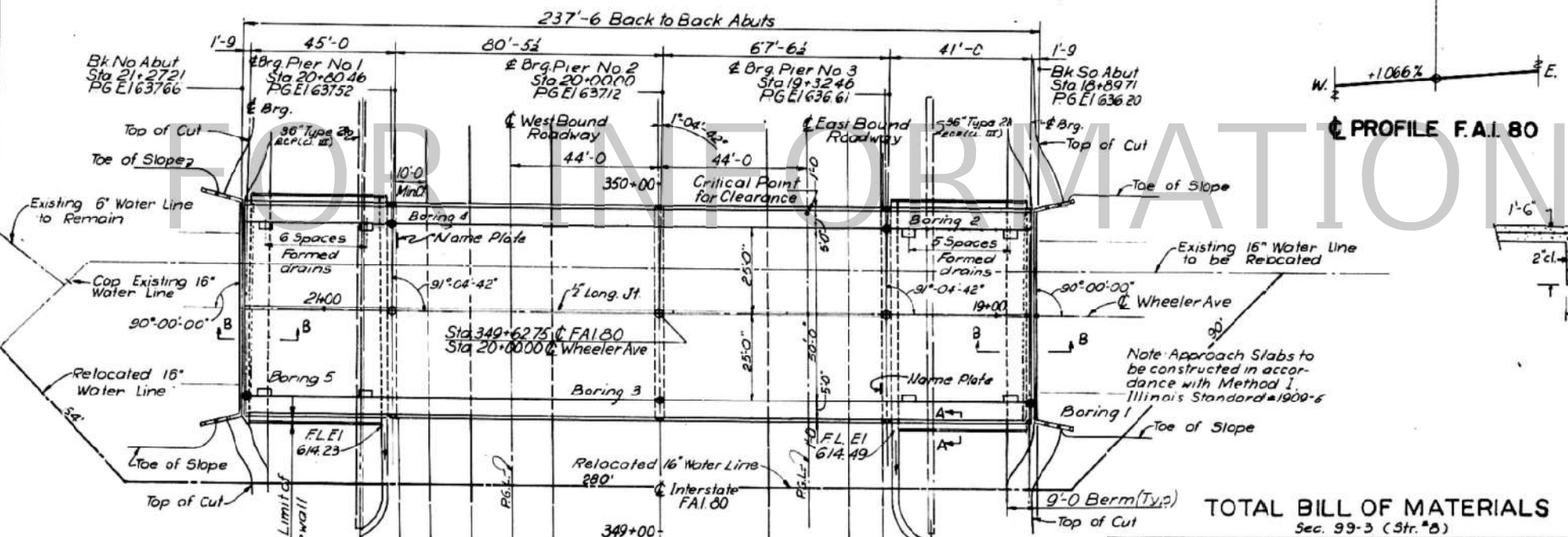
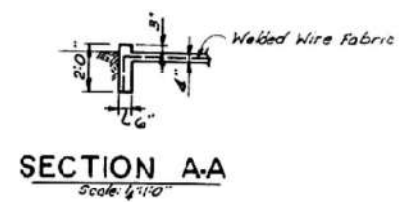
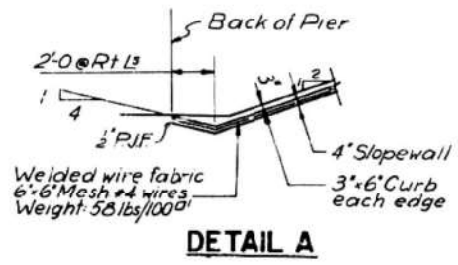

**TOTAL BILL OF MATERIALS**  
Sec. 99-3 (Str. #B)

Item	Unit	Super	Sub.	Total
* Class A Excavation for Structures	Cu. Yd.		618	618
Class X Concrete for structures	Cu. Yd.	450.1		450.1
Furnishing & Erecting Structural Steel	Lb.	488,660		488,660
Reinforcement Bars	Lb.	93,120	38,860	131,980
Name Plates	Each	2		2
Slope wall 4'	Sq. Yd.		674	674
Aluminum Handrail	Lvs. Ft.	471		471
Bridge Seat Sealant	Lump Sum		0.1	0.1
Protective Coat	Sq. Yd.	1,750		1,750

\* Includes excv. for slope wall.  
\*\* Applied at Abutment.

DESIGNED	LAN
CHECKED	RDL
DRAWN	ER
CHECKED	JTL

Note: Piers are parallel to  $\pm$  of FAI 80.  
Abutments are normal to  $\pm$  Wheeler Ave.  
• Denotes Boring Location.

Prepared and Recommended by  
Blauvelt Engineering Co.  
Structural Engineer # 81-2251  
Rosa H. Wangmuth

**GENERAL PLAN & ELEVATION**  
**WHEELER AVE. OVER FAI 80**  
FAI 80 STA. 349+62.75  
FAI ROUTE 80 SECTION 99-3HB  
PROJECT 1-80-4(22)133  
WILL COUNTY  
Scale NO SCALE Date: NOV. 30, 1961  
BLAUVELT ENGINEERING CO.  
CONSULTING ENGINEERS  
WOODBURY, N. J. NEW YORK, N. Y. CRYSTAL LAKE, ILL.

MODEL: Sheet  
FILE NAME: pw://transys/pw/bentley.com:TRANSSYS/PROJECTS/2018/CH401/40118002202-Transys/CAD/62R30/Sheets/23-Structural/099-8324/0998324-CR-03-03-3-ExistingPlan\_11.dgn  
8/10/2022 2:54:32 PM



USER NAME =	DESIGNED - MK	REVISIONS -
	CHECKED - DD	REVISIONS -
PLOT SCALE =	DRAWN - MK	REVISIONS -
PLOT DATE =	CHECKED - DD	REVISIONS -

STATE OF ILLINOIS  
DEPARTMENT OF TRANSPORTATION

EXISTING PLANS - II  
STRUCTURE NO. 099-0175

FAI RTE.	SECTION	COUNTY	TOTAL SHEETS	SHEET NO.
80	FAI 80 21 STRUCTURE 9	WILL	130	90

CONTRACT NO. 62R30  
ILLINOIS FED. AID PROJECT

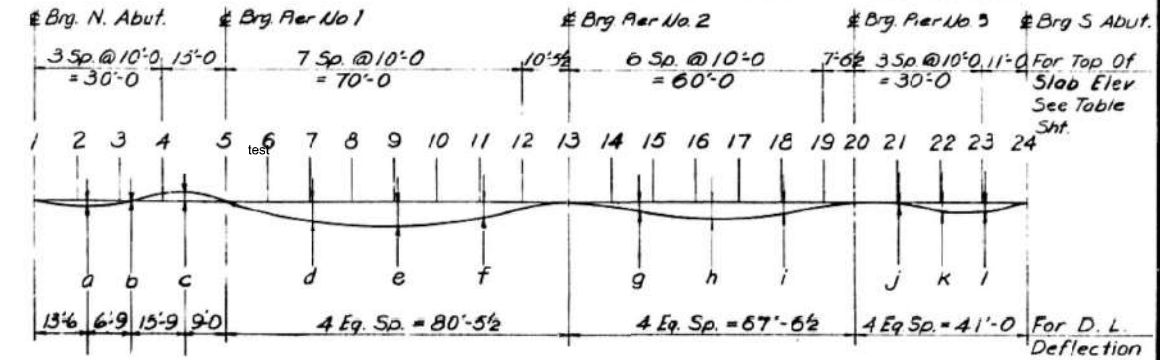
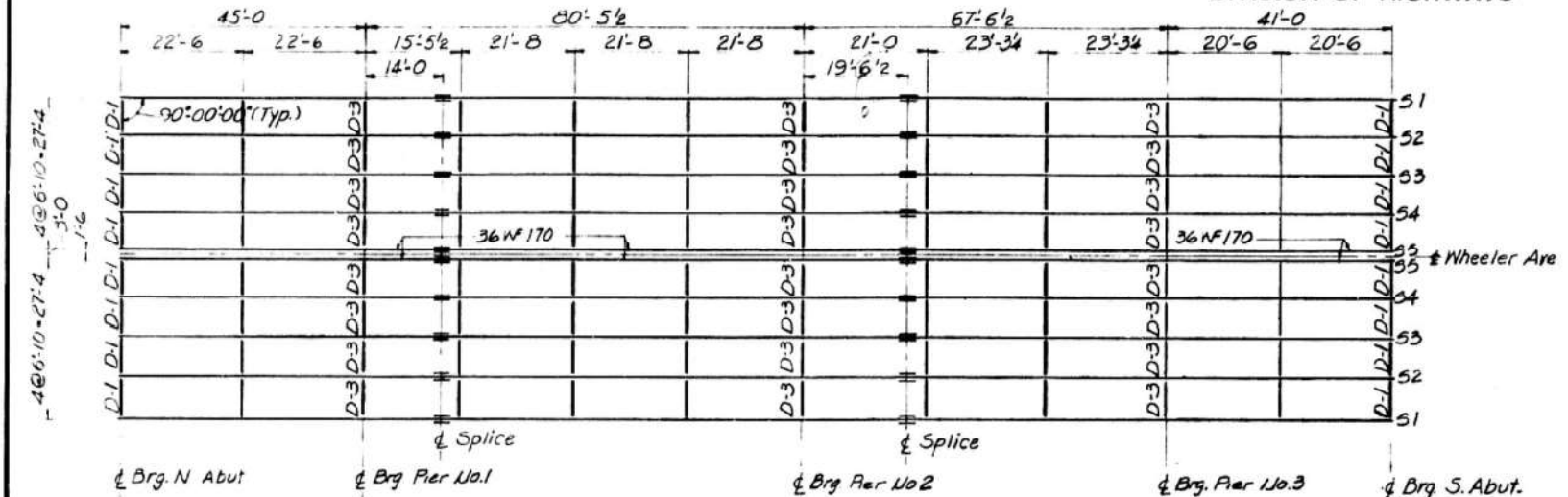

Angles shall be held securely in place, while pouring concrete with 3/8" bolts in 3/4" holes at 12 cts. All bolts shall be burned, sawed or clipped flush with back of angles after forms are removed.

Note: All diaphragms are Mark D-2 unless noted otherwise. All stringers are 36 WF 132 unless noted otherwise. All dimensions are measured in a horizontal plane.

NOTES

1"x12" Anchor Bolts to be grouted into drilled holes after beams are in place, or bolts at fixed pier may be built into the masonry. D= 3/8" @ 100 ft. of exp. for every 15° below the normal temp. of 50°F. D= 5/8" @ 100 ft. of exp. for every 15° above the normal temp. of 50°F.

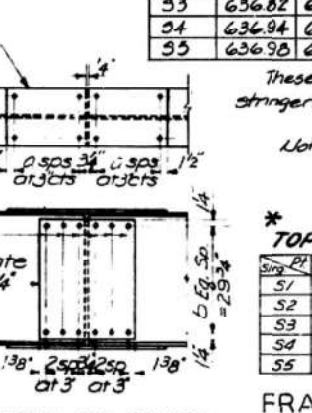
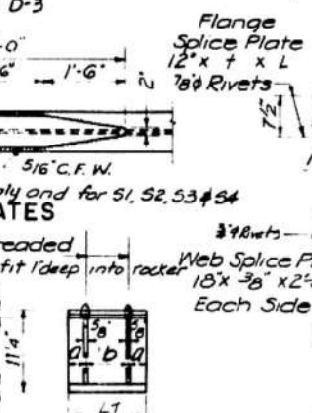
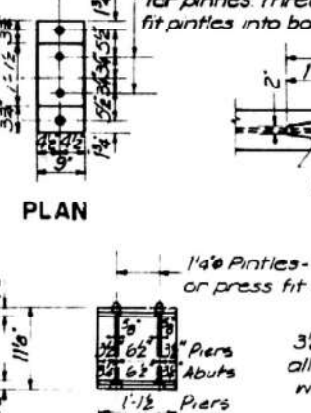
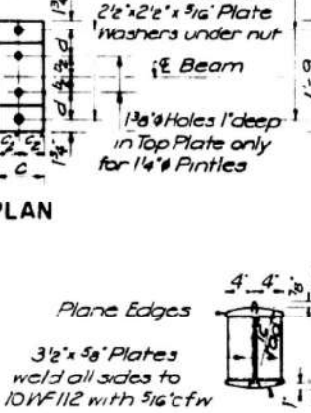
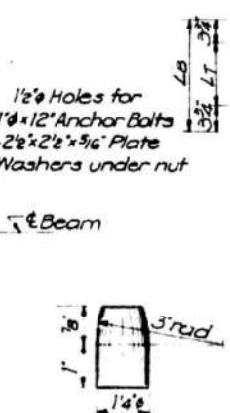
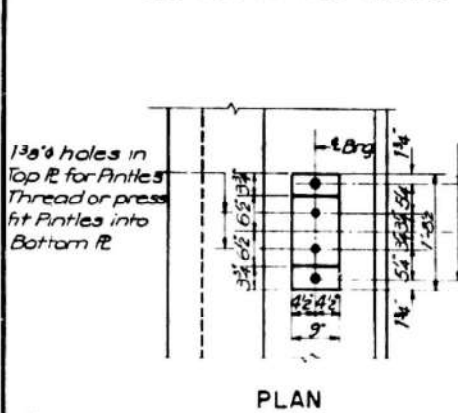
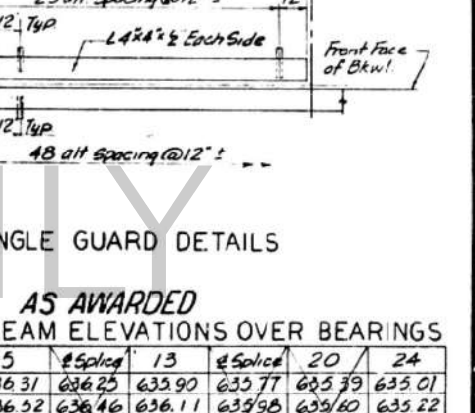
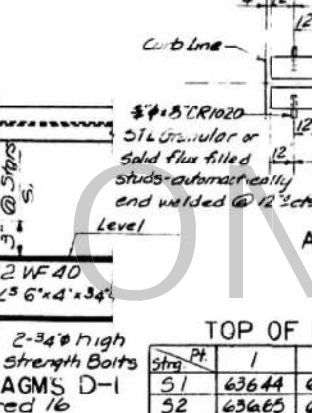
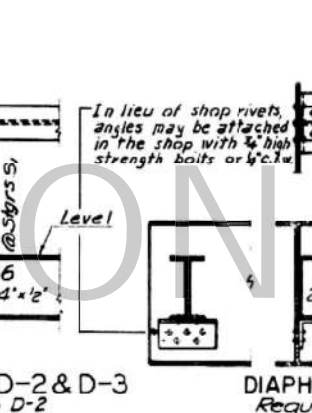
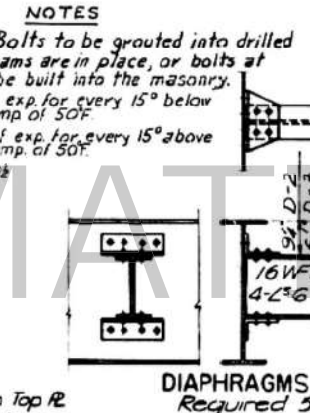
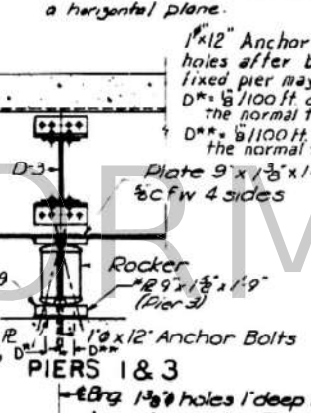
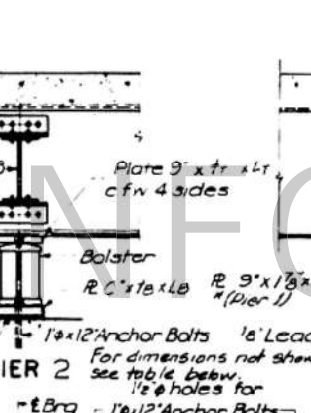
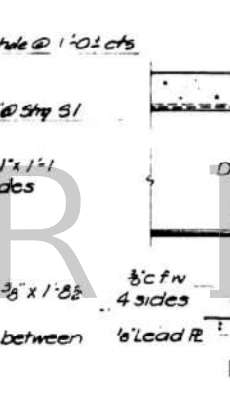
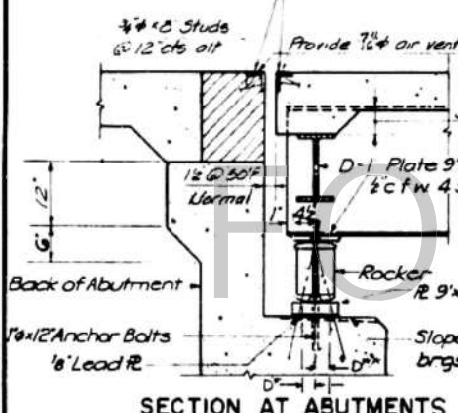

AS AWARDED  
TOP OF BEAM ELEVATIONS OVER BEARINGS

Strg	Pt	1	5	# Splice	13	# Splice	20	24
S1		636.44	636.31	636.25	635.90	635.77	635.39	635.01
S2		636.65	636.52	636.46	636.11	635.98	635.60	635.22
S3		636.82	636.69	636.64	636.29	636.15	635.78	635.39
S4		636.84	636.81	636.75	636.40	636.27	635.89	635.51
S5		636.98	636.85	636.79	636.45	636.31	635.94	635.55

AS BUILT  
TOP OF BEAM ELEVATIONS OVER BEARINGS

Strg	Pt	# Splice	20
S1		636.27	635.79
S2		636.48	636.00
S3		636.68	636.17
S4		636.77	636.29
S5		636.81	636.39

DESIGNED	GF
CHECKED	LD
DRAWN	AME
CHECKED	GF

Stringers	Lt	Tt	Lb	Tb	a	b	c	d	C/W
S1, S2, S3, S4	1'-0"	1'-6"	1'-7 1/2"	1'-8"	3"	6"	10"	5"	2"
S5	1'-1 1/2"	1'-3"	1'-9"	1'	3"	6 1/2"	9"	5 1/2"	3"

Stringers	L	a	b
S1, S2, S3, S4	1'-6"	11"	10"
S5	1'-5 1/4"	10"	9"

\* As Built: Revised Top of Beam Elevations of Splices and at 20. Revised Brg R at Pier 3 4-12-66 L W

12-7-64 J.M.J. Rev. c.p. from 11' x 3/8" x 7'-6" to 11' x 3/8" x 12'-0"

MODEL: Sheet FILE NAME: pw:\transystems-pw\h1\18002202-Transystems\CAD\628305\Sheets\2-3-Structural\099-8324\0998324-CR-03-03-4-ExistingPlan\_111.dgn



USER NAME =	DESIGNED - MK	REVISIONS -
PLOT SCALE =	CHECKED - DD	REVISIONS -
PLOT DATE =	DRAWN - MK	REVISIONS -
	CHECKED - DD	REVISIONS -

STATE OF ILLINOIS  
DEPARTMENT OF TRANSPORTATION

EXISTING PLANS - III  
STRUCTURE NO. 099-0175

SHEET S-34 OF S-43 SHEETS

FAI RTE.	SECTION	COUNTY	TOTAL SHEETS	SHEET NO.
80	FAI 80 21 STRUCTURE 9	WILL	130	91

CONTRACT NO. 62R30

ILLINOIS FED. AID PROJECT

STATE OF ILLINOIS  
DEPARTMENT OF PUBLIC WORKS & BUILDINGS  
DIVISION OF HIGHWAYS

SHEET NO 5A  
5 SHEETS

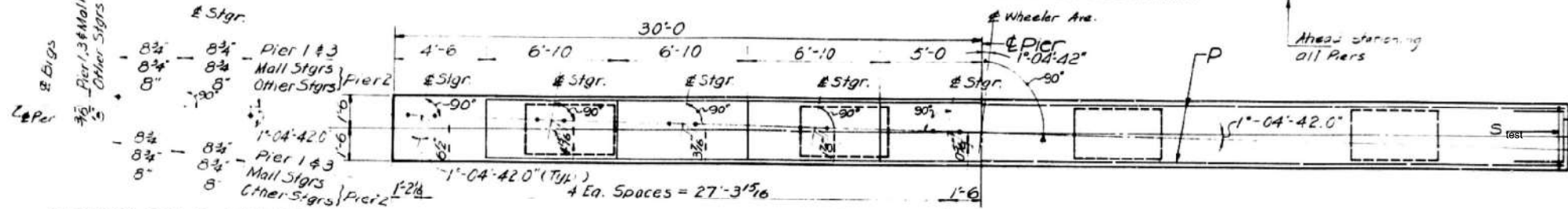

TOP PLAN

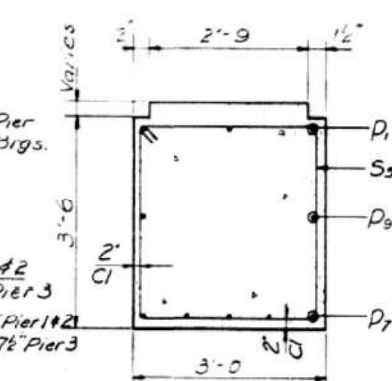

SECTION A-A

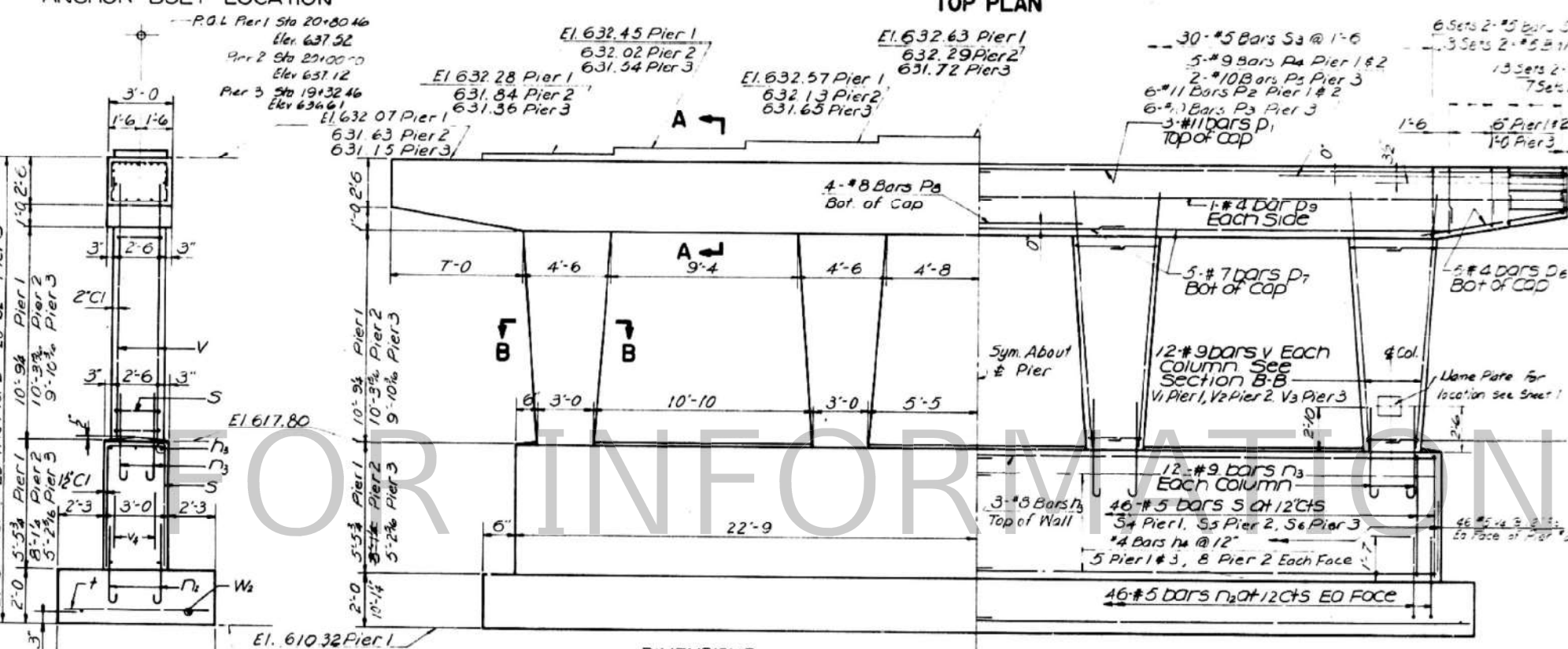

ELEVATION

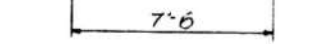

END VIEW

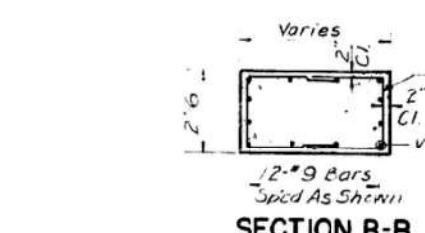

SECTION B-B

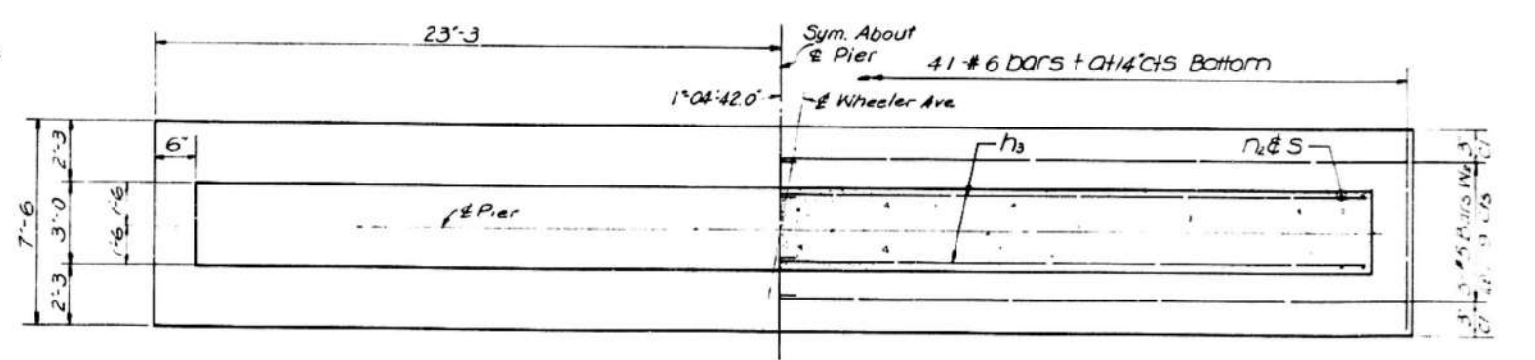

FOOTING PLAN

3 PIERS  
BILL OF MATERIAL

BAR NO	SIZE	LGTH	SHAPE
n1	#8	23'-5"	—
n2	#5	23'-2"	—
n3	#5	3'-11"	—
n4	#9	5'-8"	—
n5	#11	31'-8"	—
n6	#11	15'-1"	—
n7	#10	14'-9"	—
n8	#9	9'-10"	—
n9	#10	10'-3"	—
n10	#4	7'-11"	—
n11	#7	16'-4"	—
n12	#8	10'-0"	—
n13	#4	30'-4"	—
n14	#5	6'-8"	—
n15	#5	7'-0"	—
n16	#5	12'-8"	—
n17	#5	13'-2"	—
n18	#5	18'-6"	—
n19	#5	12'-8"	—
n20	#4	7'-4"	—
n21	#6	7'-0"	—
n22	#6	10'-8"	—
n23	#9	13'-6"	—
n24	#9	13'-1"	—
n25	#9	12'-7"	—
n26	#5	23'-6"	—
n27	#5	4'-0"	—

A & B DIMENSIONS

BAR NO	A	B
s1	2'-8"	2'-0"
s2	2'-8"	2'-2"
s3	2'-8"	5'-3"
s4	2'-8"	7'-11"
s5	2'-8"	5'-0"
s6	2'-2"	2'-7"

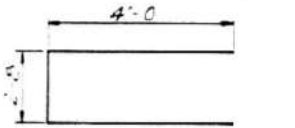

u BARS

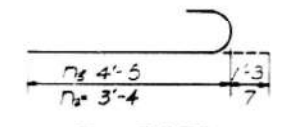

n2 & n3 BARS

CLASS	COUNT	CU. YD.
Class X Conc Pier 1	93.2	93.2
Class X Conc Pier 2	106.0	106.0
Class X Conc Pier 3	90.4	90.4
Reinforcing Bars	30,190	30,190
Class A Exc Pier 1	101	101
Class A Exc Pier 2	89	89
Class A Exc Pier 3	108	108

Maximum Soil Bearing Pressure = 2 1/2 Tons/Sq. ft.

AS BUILT

PIERS  
WHEELER AVE.  
OVER F.A.I. 80  
F.A.I. 80 STA. 349+62.75

F.A.I. ROUTE 80 SECTION 99-3 (5th AB) PROJECT  
SCALE: NC SCALE DATE: Nov 30 1961

BLAUVELT ENGINEERING CO.  
CONSULTING ENGINEERS  
NEW YORK N.Y. CRYSTAL LAKE, ILL.

DESIGNED	G F
CHECKED	LD
DRAWN	J H
CHECKED	LD

Rev. 1-14-66 W.L.P. Lower Pier 2 Fig. to El. 605.70. Added 92 5/8" at 4'-0" long, Increase Class x Concrete from 90.4 cu. yd. to 100.5 cu. yd., and Reinf Bars from 30,190 lbs to 30,570 lbs.

MODEL: Sheet  
FILE NAME: pw://transsystems-pw.bentley.com/TRANSYS/PC/PW1-HOSTED/Projects/2018/CH401/40118002202-TransSystems/CAD/62R30/5heets/23-Structural/099-8324-CR-03-03-5-ExistingPlan\_IV.dgn  
8/10/2022 2:54:51 PM



USER NAME =	DESIGNED - MK	REVISED -
	CHECKED - DD	REVISED -
PLOT SCALE =	DRAWN - MK	REVISED -
PLOT DATE =	CHECKED - DD	REVISED -

STATE OF ILLINOIS  
DEPARTMENT OF TRANSPORTATION

EXISTING PLANS - IV  
STRUCTURE NO. 099-0175  
SHEET S-35 OF S-43 SHEETS

F.A.I. RTE.	SECTION	COUNTY	TOTAL SHEETS	SHEET NO.
80	FAI 80 21 STRUCTURE 9	WILL	130	92

CONTRACT NO. 62R30  
ILLINOIS FED. AID PROJECT

STATE OF ILLINOIS  
DEPARTMENT OF TRANSPORTATION  
DIVISION OF HIGHWAYS

**PLANS FOR PROPOSED  
HIGHWAY IMPROVEMENT**

**FAI 80 (I-80)  
UNDER  
WHEELER AVENUE  
SECTION 99-3HB-1**

**PROJECT NO. ACBHI-80-4(180)133**

**BRIDGE DECK REMOVAL /REPLACEMENT /RECONFIGURATION,  
SUPERSTRUCTURE AND SUBSTRUCTURE REHABILITATION AND  
APPROACH ROADWAY RECONSTRUCTION AND /RESURFACING RELATED WORK  
WILL COUNTY**

C-91-153-99

F.A.I. RTE.	SECTION	COUNTY	TOTAL SHEETS	SHEET NO.
80	99-3HB-1	WILL	130	93
FED. ROAD DIST. NO.		ILLINOIS	FED. AID PROJECT	
ACBHI-80-4(180)133				



FOR INDEX OF SHEETS, SEE SHEET NO. 2

PROJECT LOCATED WITHIN  
THE CITY LIMITS OF JOLIET

DESIGN DESIGNATION  
2700(15) MINOR ARTERIAL (URBAN)(BIT.20)

TRAFFIC DATA

2700 (1995) ADT  
2700 (2015) ADT  
PROJECT SPEED LIMIT: 45 MPH



FULL SIZE PLANS HAVE BEEN PREPARED USING STANDARD  
ENGINEERING SCALES, REDUCED SIZED PLANS WILL NOT  
CONFORM TO STANDARD SCALES, IN MAKING MEASUREMENTS  
ON REDUCED PLANS, THE ABOVE SCALES MAY BE USED.

**JULIE**  
JOINT UTILITY LOCATION INFORMATION FOR EXCAVATION  
1-800-882-0123

**CONTRACT NO. 60741**



IMPROVEMENT ENDS  
STA. 22+57.82

SECTION 99-3HB-1, INCLUDES THE REMOVAL AND  
REPLACEMENT OF THE BRIDGE DECK OF SN 099-0115  
INTO, A FOUR SPAN, WIDE FLANGE STEEL BEAM CONCRETE  
DECK STRUCTURE CARRYING WHEELER AVENUE OVER I-80.  
WORK ALSO INCLUDES SUPERSTRUCTURE AND  
SUBSTRUCTURE REHABILITATION AND APPROACH  
ROADWAYS AND THEIR APPURTENANCES.

IMPROVEMENT BEGINS  
STA. 16+41.80

GROSS LENGTH OF IMPROVEMENT = 616.00 FT = 0.12 MILE  
NET LENGTH OF IMPROVEMENT = 616.00 FT = 0.12 MILE

5/14/01  
Exp. 11/30/01  
Natarafano, Wynn  
and Associates, Inc.  
ENGINEERS ARCHITECTS SURVEYORS  
205 WEST WACKER DRIVE  
CHICAGO, ILLINOIS 60606

STATE OF ILLINOIS  
DEPARTMENT OF TRANSPORTATION  
DIVISION OF HIGHWAYS

SUBMITTED June 22, 2001

James L. Kue DISTRICT ENGINEER

August 17, 2001

Michael Klein ENGINEER OF DESIGN AND ENVIRONMENT

August 17, 2001

James R. Steg DIRECTOR, DIVISION OF HIGHWAYS

FOUNDED BY THE AUTHORITY OF  
THE STATE OF ILLINOIS

MODEL: Sheet  
FILE NAME: pw://transystems-pw.bentley.com:TRANSCORP-PW1-HOSTED/Projects\_2018/CH401/401180022/02-TransSystems/CAD/62830/Sheets/23-Structural/099-8324/0998324-CR-03-036-ExistingPlan\_V.dgn

IDOT-DISTRICT 1-CONSULTANT PROJECT ENGINEER : ANIK THAKKAR (847) 705-4555



USER NAME =	DESIGNED - MK	REVISED -
	CHECKED - DD	REVISED -
PLOT SCALE =	DRAWN - MK	REVISED -
	CHECKED - DD	REVISED -
PLOT DATE =		

STATE OF ILLINOIS  
DEPARTMENT OF TRANSPORTATION

EXISTING PLANS - V  
STRUCTURE NO. 099-0175

SHEET S-36 OF S-43 SHEETS

F.A.I. RTE.	SECTION	COUNTY	TOTAL SHEETS	SHEET NO.
80	FAI 80 21 STRUCTURE 9	WILL	130	93
				CONTRACT NO. 62R30
		ILLINOIS FED. AID PROJECT		

Bench Mark: TBM 17 - Cut on top of east side of crash wall in I-80 median under Wheeler Ave. U.S.G.S. Elev. = 618.03 = Project Elev. 617.79 (To Match Exist. Elevations)

Existing Structure: S.N. 099-0175, four span continuous multi-steel beam bridge on multi-column R.C. piers and spill through abutments. Built in 1966 by IDOT as Proj. I-80-4 (22) 133 Sec. 99-34B in Will County. Total length back to back abutment is 237'-6". Clear width between curbs is 50'-0". Total width Out to Out of deck is 62'-0".

Concrete Deck to be removed and replaced. Traffic to be maintained utilizing stage construction.

No Salvage.

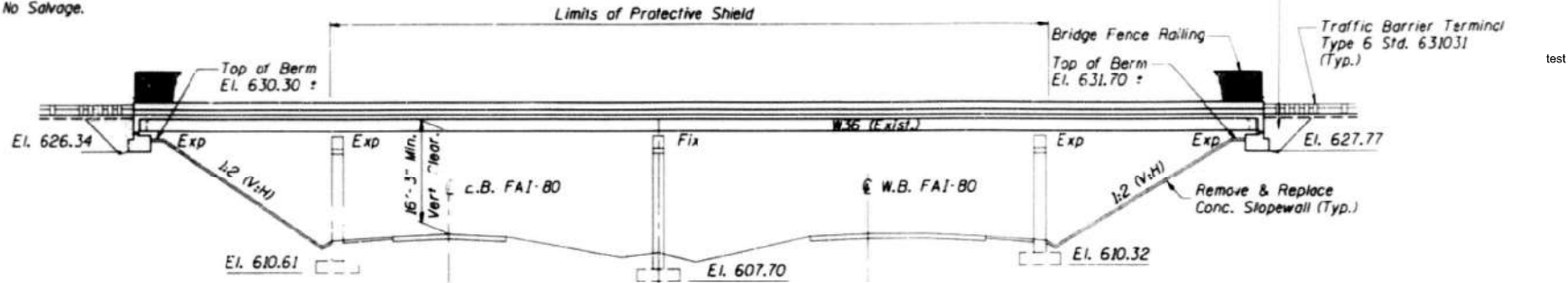

ELEVATION

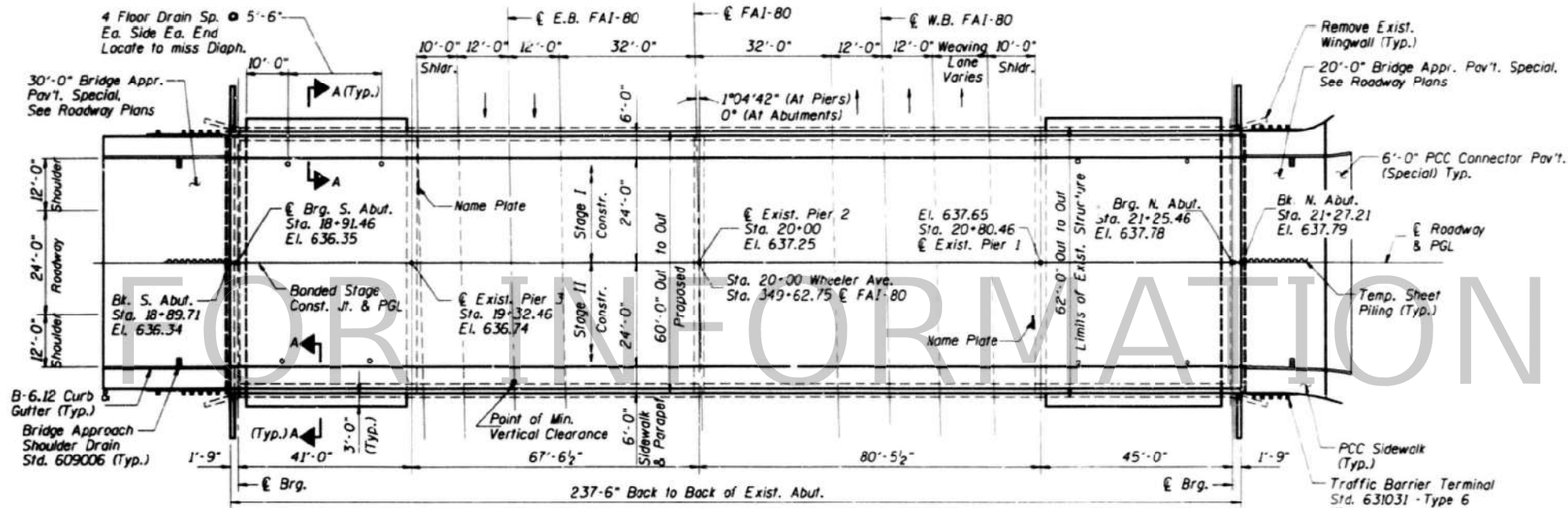

PLAN

Note: For Section A-A, see Sheet S2

TOTAL BILL OF MATERIAL

ITEM	UNIT	SUPER	SUB	TOTAL
Removal of Existing Concrete Deck	Each	1		1
Concrete Removal	Cu. Yd.		46	46
Concrete Superstructure	Cu. Yd.	501.5		501.5
Concrete Structures	Cu. Yd.		33	33
Reinforcement Bars, Epoxy Coated	Lbs.		4060	4060
Protective Coat	Sq. Yd.	1729		1729
Bridge Deck Grooving	Sq. Yd.	1206		1206
Floor Drains	Each	16		16
Bar Splicers	Each	900	16	916
Protective Shield	Sq. Yd.	1047		1047
Furnishing and Erecting Structural Steel	Lbs.	760		760
Elastomeric Bearing Assembly, Type I	Each	10		10
Elastomeric Bearing Assembly, Type II	Each	10		10
Name Plates	Each		2	2
Stud Shear Connectors	Each	5040		5040
Slopedwall Removal	Sq. Yd.		674	674
Slopedwall 4 Inch	Sq. Yd.		715	715
Structure Excavation	Cu. Yd.		381	381
Porous Granular Embankment	Cu. Yd.		359	359
Epoxy Crack Sealing	Lin. Ft.		125	125
Temp. Sheet Piling	Sq. Ft.		647	647
Jack & Remove Exist. Bearings	Each	20		20
Bridge Fence Railing	Lt.	475		475

\* The limits of the Protective Shield shall be the out-to-out width of the existing deck and from 2 feet south and north of E Pier 1 & Pier 3 respectively.

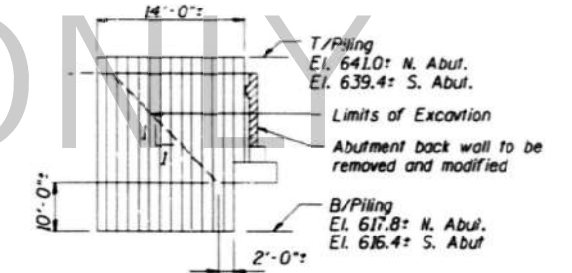

AT ABUTMENTS

Note: If the Contractor chooses to alter the temporary cantilevered sheet piling requirements shown on these plans for lesser design requirements, then full design submittals sealed by an Illinois Licensed Structural Engineer will be required and submitted to the Department for review and approval.

Excavation Slope at Rt. L to Abut.

TEMPORARY SHEET PILING DETAILS

Minimum Section Modulus = 18.1 in.<sup>3</sup>/ft.  
Minimum Embedment Depth = 10' ±

DESIGN SPECIFICATIONS

1996 AASHTO with 1997, 1998 & 1999 Interims

LOADING HS20-44

Allow 50#/sq. ft. for future wearing surface.

DESIGN STRESSES

EXISTING	PROPOSED
$f_c = 3,500$ psi	$f_c = 3,500$ psi
$f_s = 20,000$ psi (Reinf.)	$f_s = 60,000$ psi (Reinf.)
$f_a = 20,000$ psi (Struct.)	$f_s = 36,000$ psi (N270 Grade 36)

SEISMIC DATA

Seismic Performance Category (SPC) = A  
Bedrock Acceleration Coefficient (A) = 3.8% g  
Site Coefficient (S) = 1.0

APPROVED FOR STRUCTURAL ADEQUACY

ENGINEER OF BRIDGE AND STRUCTURES

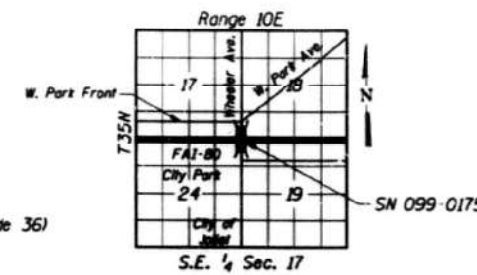

LOCATION SKETCH



Manufacturers, Engineers and Architects, Inc.  
205 WEST BUCKER DRIVE  
CHICAGO, ILLINOIS 60604

GENERAL PLAN & ELEVATION

WHEELER AVENUE  
OVER FAI-80  
STA. 349+62.75  
FAI ROUTE 80  
SECTION 99-34B-1  
WILL COUNTY  
STRUCTURE NUMBER 099-0175

DESIGNED	JM
CHECKED	EMM
DRAWN	JM/MR
CHECKED	EMM

STATION 349+62.75  
REBUILT 20 BY  
STATE OF ILLINOIS  
FAI ROUTE 80  
SEC. 99-34B  
LOADING HS20  
STR. NO. 099-0175

NAME PLATE  
See Std. 515001

Note: Locate new Name Plates next to existing Name Plates.

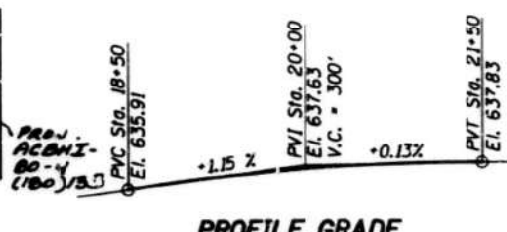

PROFILE GRADE  
(Along E Wheeler Avenue)

MODEL: Sheet  
FILE NAME: pw:\transystems-pw\benley.com\TRANSYSCORP-PW1-HOSTED\Documents\Projects\_2018\CH401\40118002202-TransSystems\CAD\62830\Sheets\23-Structural\099-8324\0998324-CR-03-037-ExistingPlan\_VI.dgn



USER NAME =	DESIGNED - MK	REVISED -
	CHECKED - DD	REVISED -
PLOT SCALE =	DRAWN - MK	REVISED -
PLOT DATE =	CHECKED - DD	REVISED -

STATE OF ILLINOIS  
DEPARTMENT OF TRANSPORTATION

EXISTING PLANS - VI  
STRUCTURE NO. 099-0175

SHEET S-37 OF S-43 SHEETS

F.A.I. RTE.	SECTION	COUNTY	TOTAL SHEETS	SHEET NO.
80	FAI 80 21 STRUCTURE 9	WILL	130	94
CONTRACT NO. 62R30				
ILLINOIS FED. AID PROJECT				

ROUTE NO.	SECTION	COUNTY	TOTAL SHEETS	SHEET NO.	SHEET NO. 56 OF
F.A.I. 80	99-386-1	WILL	37	15	17 SHEETS
FED. ROAD DIST. NO. 7	ILLINOIS	FED. AID PROJECT-			

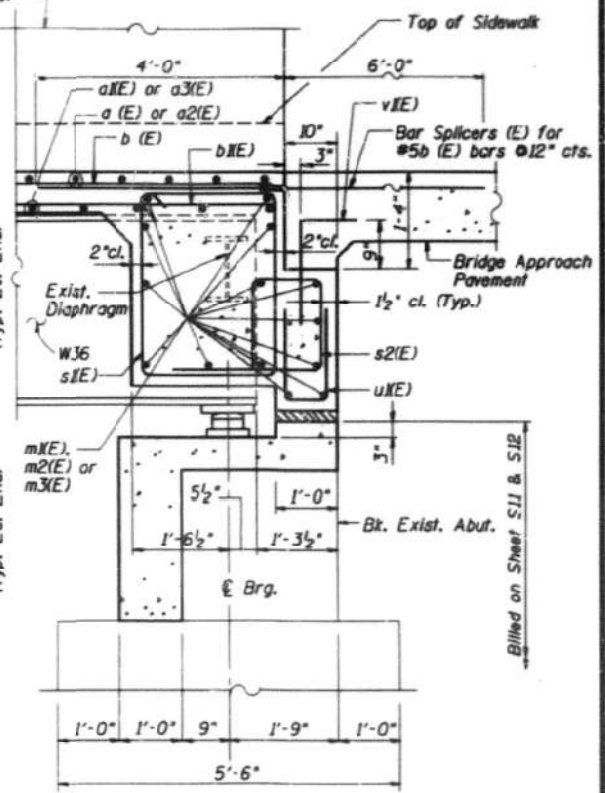
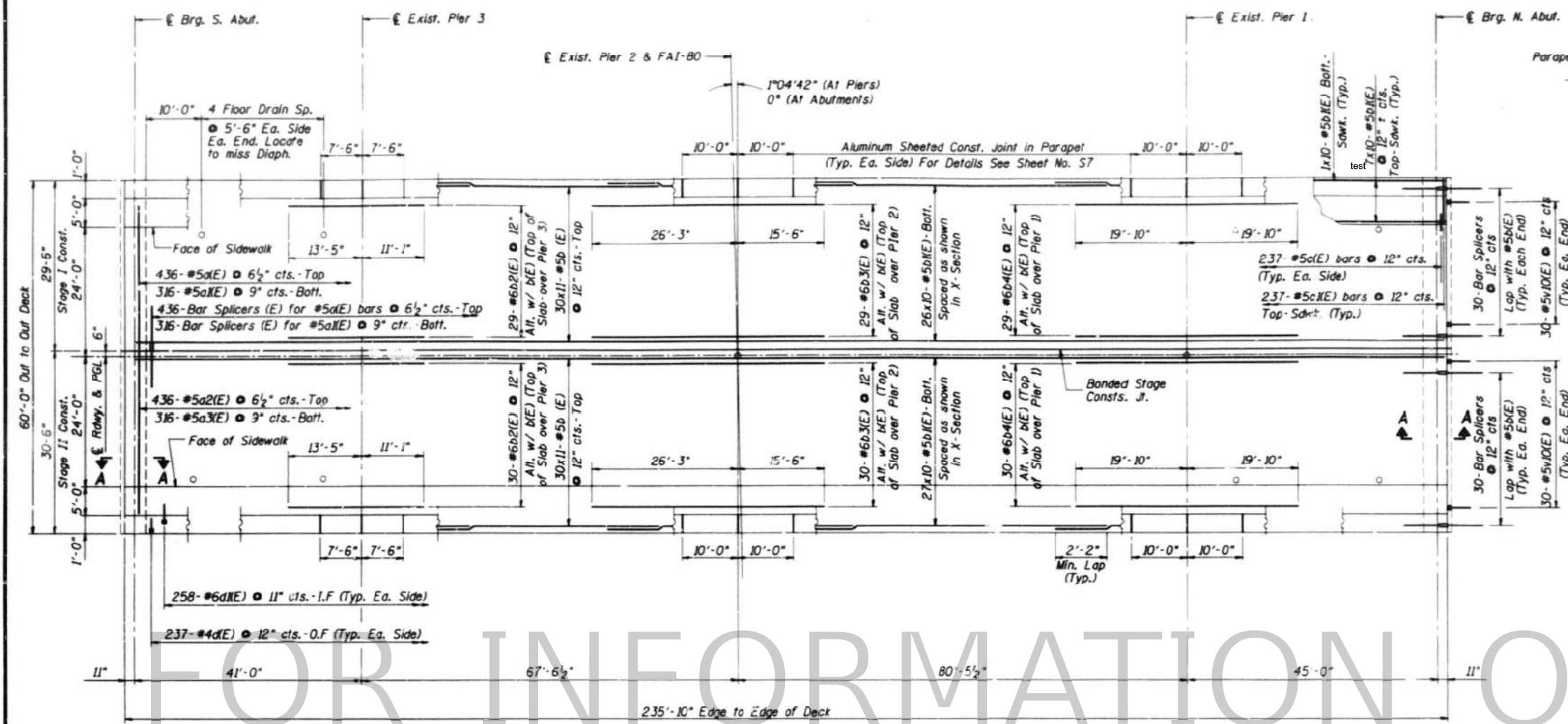

FOR INFORMATION ONLY

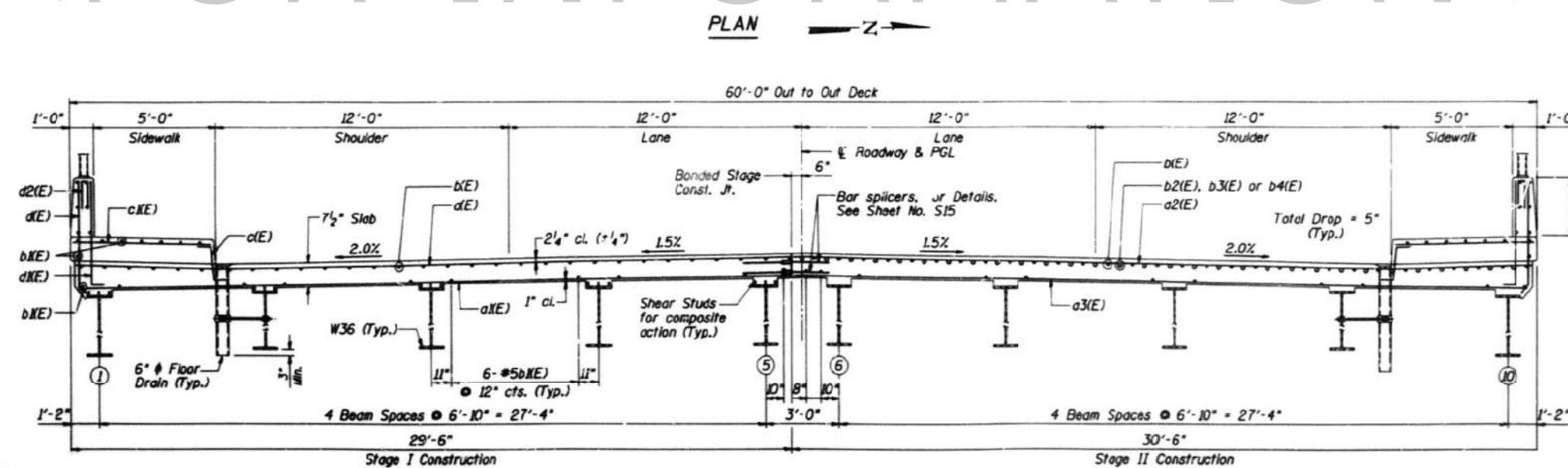

- Notes:
1. Reinforcement Bars designated (E) shall be Epoxy Coated.
  2. Reinforcement Bars designated Thus : 30x11-#5, etc. Indicates 30 Lines with 11 Lengths per Line.
  3. Cut Longitudinal reinforcement and space transverse reinforcement to clear floor drain.
  4. See Sheet No. S-7 for Bill of Material.

**DECK PLAN CROSS SECTION & DETAIL**

**WHEELER AVENUE  
OVER FAI-80  
STA. 348+62.75  
FAI ROUTE 80  
SECTION 99-386-1  
WILL COUNTY  
STRUCTURE NUMBER 099-0175**

DESIGNED	JPM
CHECKED	EMM
DRAWN	MR
CHECKED	EMM

USER NAME =	DESIGNED - MK	REVISED -
PLOT SCALE =	CHECKED - DD	REVISED -
PLOT DATE =	DRAWN - MK	REVISED -
	CHECKED - DD	REVISED -

**STATE OF ILLINOIS  
DEPARTMENT OF TRANSPORTATION**

**EXISTING PLANS - VII  
STRUCTURE NO. 099-0175**

F.A.I. RTE.	SECTION	COUNTY	TOTAL SHEETS	SHEET NO.
80	FAI 80 21 STRUCTURE 9	WILL	130	95
			CONTRACT NO. 62R30	
ILLINOIS FED. AID PROJECT				

SHEET S-38 OF S-43 SHEETS

MODEL: Sheet  
FILE NAME: pw://transsystems-pw.bentley.com:TRANSYS/SCORP-PW1-HOSTED/Projects/2018/CH401/40118002202-TransSystems/CAD/62R30/Sheets/S-38-Structural/099-8324-CR-03-038-ExistingPlan\_VII.dgn  
8/10/2022 2:55:20 PM

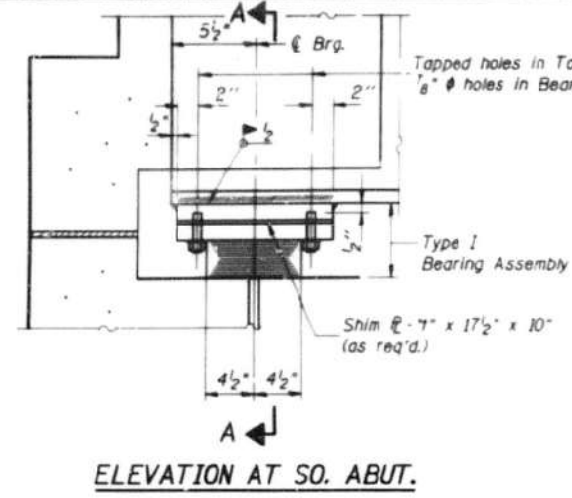

**TYPE I ELASTOMERIC EXP. BRG.**

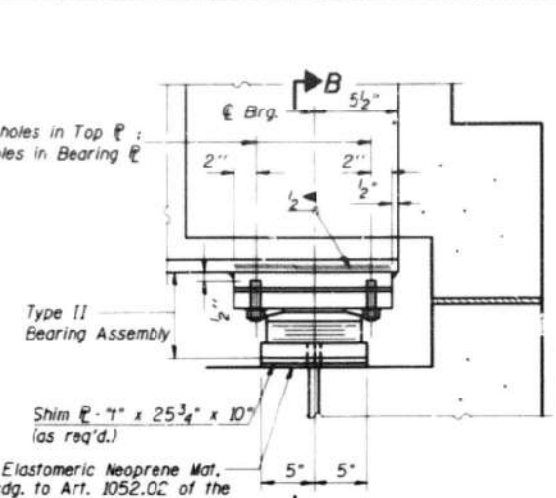
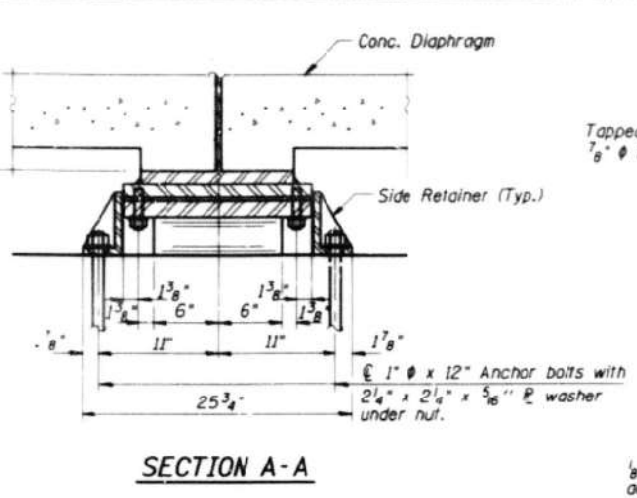

**TYPE II ELASTOMERIC EXP. BRG.**

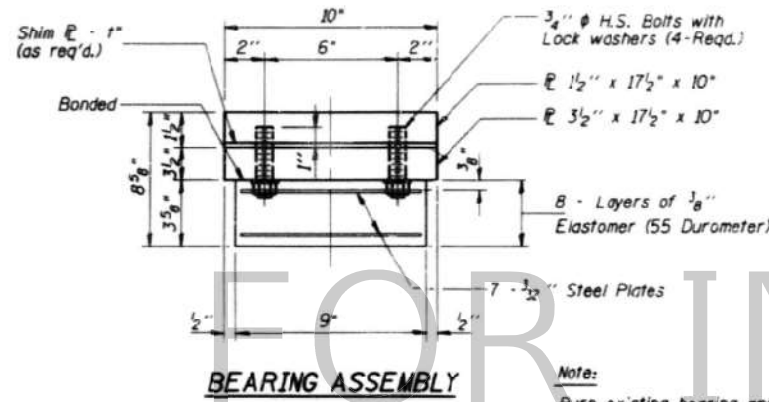
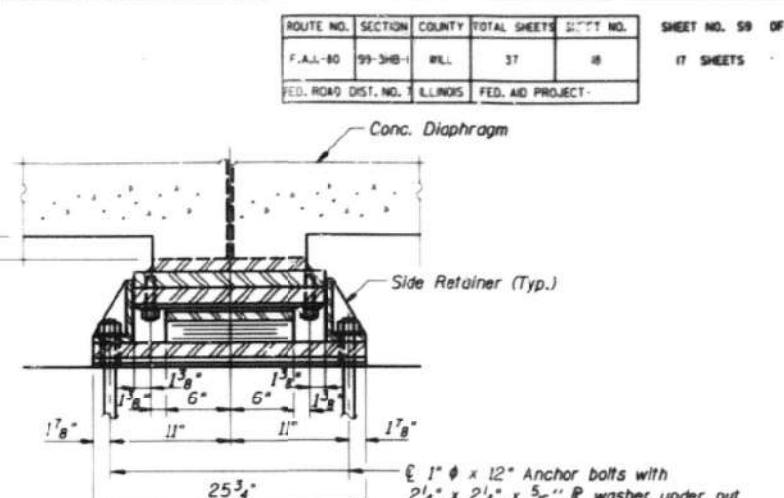

Note: Shim plates shall not be placed under Bearing Assembly.

Note: Burn existing bearing anchor bolts flush with existing concrete surface. Grind existing anchor bolt smooth and seal with epoxy. Cost is included with the "Removal of Existing Superstructure".

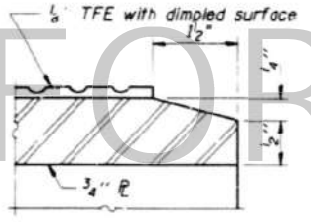
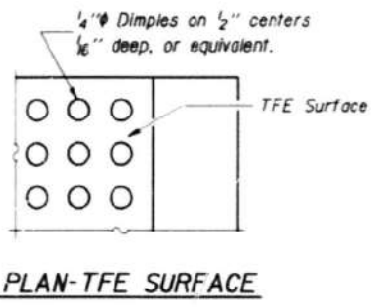

Note: The 1/8" TFE sheet shall be bonded directly to the top steel plate with a two-component, medium viscosity epoxy resin, conforming to the requirements of the Federal Specification MMM-A-134, Type I. The bond agent shall be applied on the full area of the contact surfaces.

Bonding of 1/8" TFE sheet during vulcanizing process will be permitted provided the process and method of adjusting assembly height is approved by the Engineer.

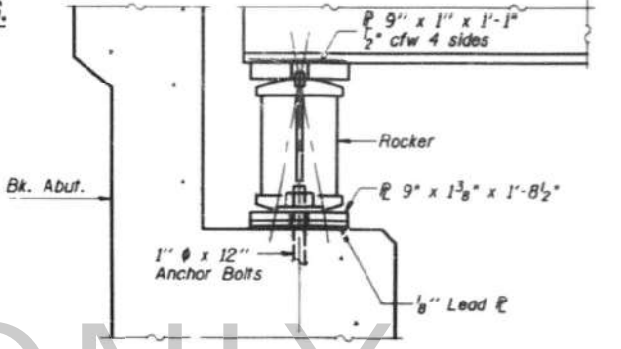
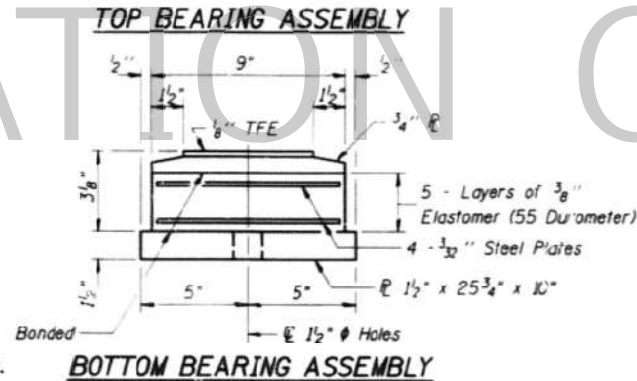
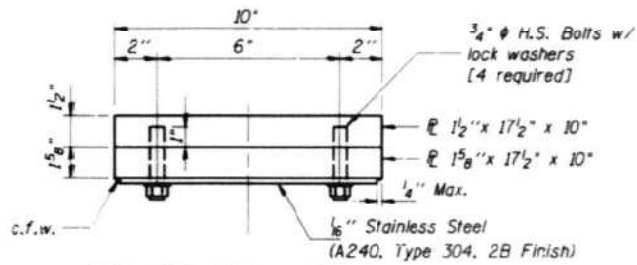

**EXIST. ABUTMENT BEARINGS TO BE REMOVED**

**NOTES - JACK AND REMOVE BEARING**

- The Contractor shall submit for approval by the engineer, plans for jacking & cribbing prior to commencing any work on the bearings.
- Jacking and removing existing bearings, including top and bottom plates and lead plates, shall be done after deck removal is completed and before the new deck is poured.
- All Stage I or Stage II beams shall be lifted simultaneously in stages.
- Remove the existing anchor bolts. Top plates welded to the bottom flange of beams shall be removed using the air-arc method. Grind smooth all weld material remaining on the bottom flange.
- The new bearings shall be in place and the jacks shall be lowered before the new deck is poured.

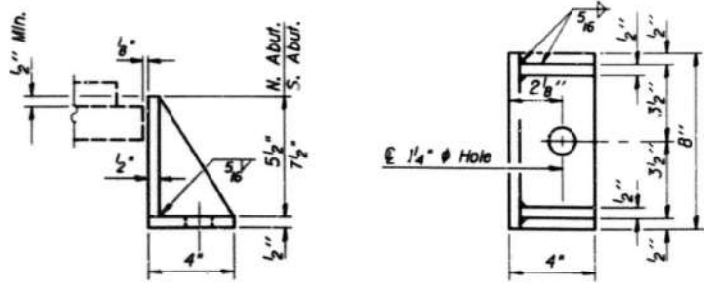

Equivalent rolled angle with stiffeners will be allowed in lieu of welded plates. Weight included with Structural Steel.

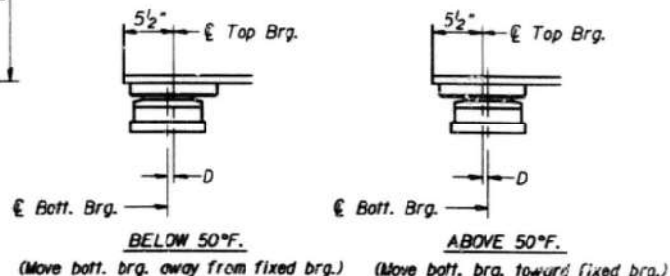

D=1/8" per each 100' of expansion for every 15° temp. change from the normal temp. of 50°F.

**BILL OF MATERIAL**

Item	Unit	Total
Elastomeric Bearing Assembly Type II	Each	10
Elastomeric Bearing Assembly Type I	Each	10

Wt. of Structural Steel this Sheet = 760 lbs.\*

\* Includes Side Retainers, Bolts, Washers and Shim Plates

**BEARING DETAILS**

**WHEELER AVE.  
OVER FAI-80  
STA. 349+62.75  
FAI ROUTE 80  
SECTION 99-318-1  
WILL COUNTY  
STRUCTURE NUMBER 099-0175**

Northrup, Wynne and Associates, Inc.  
ENGINEERS ARCHITECTS SURVEYORS  
805 WEST WACKER DRIVE  
CHICAGO, ILLINOIS 60606

MODEL: Sheet  
FILE NAME: pw://transsystems-pw.bentley.com/TRANSYS/SCORP/PW1-HOSTED/Projects\_2018/CH401/40118002202-TransSystems/CAD/62R30/Sheets/23-Structural/099-8324-CP-03-039-ExistingPlan\_VIII.dgn  
8/10/2022 2:55:29 PM



DESIGNED	JM
CHECKED	EMM
DRAWN	JM/MR
CHECKED	EMM

USER NAME	=	DESIGNED	-	MK	REVISED	-
		CHECKED	-	DD	REVISED	-
PLOT SCALE	=	DRAWN	-	MK	REVISED	-
PLOT DATE	=	CHECKED	-	DD	REVISED	-

STATE OF ILLINOIS  
DEPARTMENT OF TRANSPORTATION

EXISTING PLANS - VIII  
STRUCTURE NO. 099-0175

SHEET S-39 OF S-43 SHEETS

F.A.I. RTE.	SECTION	COUNTY	TOTAL SHEETS	SHEET NO.
80	FAI 80 21 STRUCTURE 9	WILL	130	96
ILLINOIS			FED. AID PROJECT	
CONTRACT NO. 62R30				



**BILL OF MATERIAL**

Bar	No.	Size	Length	Shape
h1 (E)	4	#5	8'-7"	
h2 (E)	8	#5	8'-8"	
h3 (E)	32	#5	7'-8"	
h4 (E)	20	#5	3'-0"	
p1 (E)	5	#6	29'-4"	
p2 (E)	5	#6	30'-4"	
p3 (E)	3	#5	18'-9"	
p4 (E)	3	#5	17'-9"	
u10 (E)	61	#5	5'-10"	
u11 (E)	61	#5	4'-3"	
u12 (E)	39	#5	3'-10"	
v2 (E)	18	#5	12'-9"	
Item	Unit	Total		
Reinforcement Bars, Epoxy Coated	Lbs.	2030		
Concrete Structures	Cu. Yd.	16.3		
Structure Excavation	Cu. Yd.	150		
Porous Granular Embankment	Cu. Yd.	175.0		
Bar Splicers	Each	8		

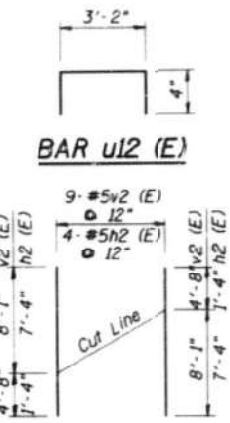

**FIELD CUTTING DIAGRAM**

Order v2 (E) and h2 (E) full length. Cut as shown and use remainder of bars in opposite face.

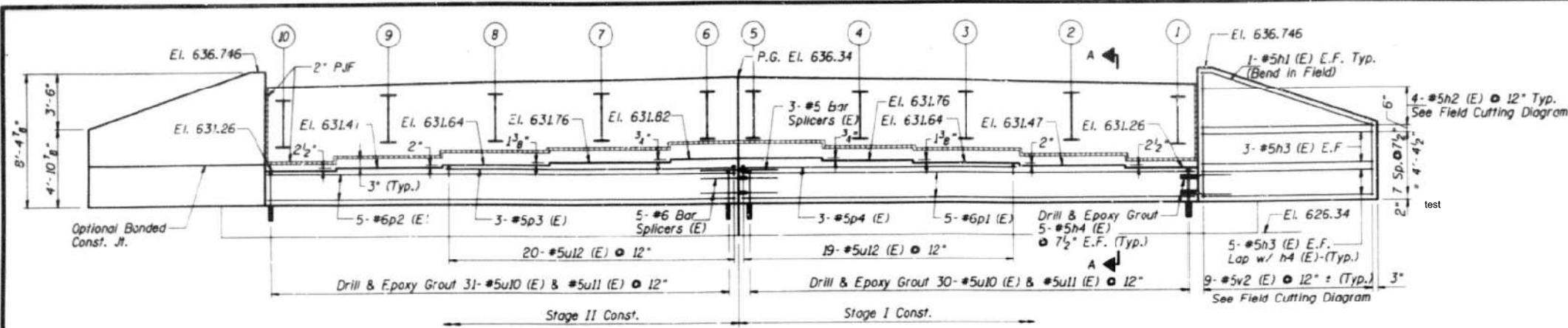
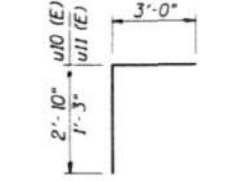

**ELEVATION**

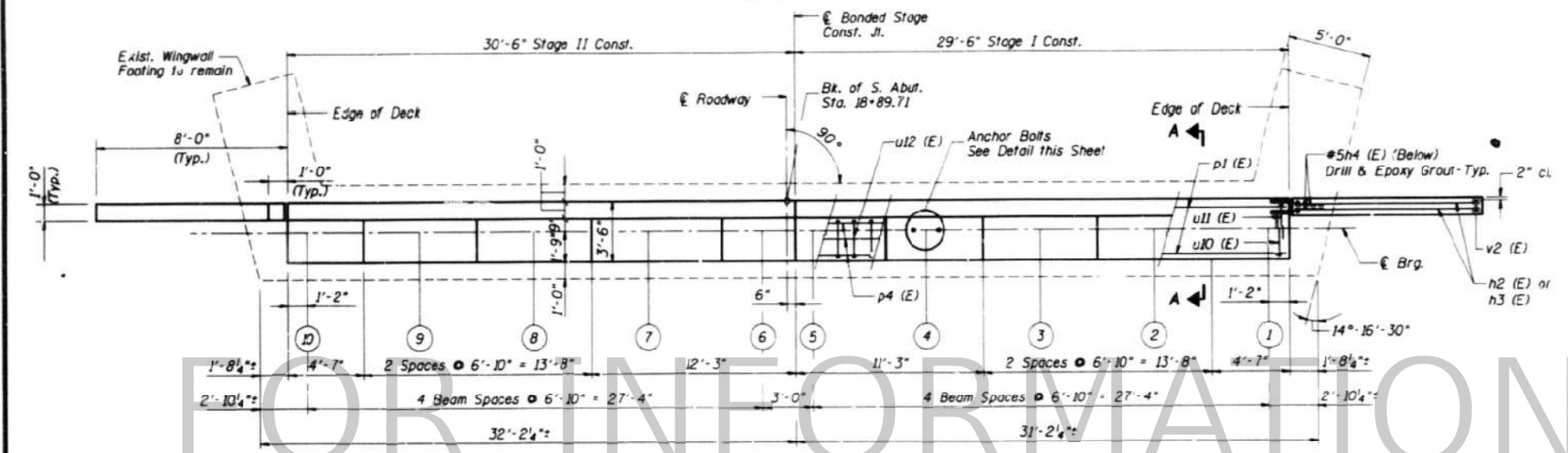

**PLAN**

**ANCHOR BOLT LAYOUT**

- 2" Preformed Joint Filler (Section 1051 of the Standard Specifications) bonded to abutment cap with approved adhesive (full width of cap)
- 1/4" thick Reinforced Elastomeric Mat attached to the abutment cap using a 3/8" x 5" steel plate (full width of cap) and 1/2" studs with nuts and washers at 12" cts. See Special Provisions.
- 2" Preformed Joint Filler (Section 1051 of the Standard Specifications) bonded to superstructure (full width of cap)
- Geocomposite Wall Drain (full width of cap plus extend 3' minimum onto wingwalls)

Items 1, 2, 3 & 4 shall be included in the cost of Concrete Superstructure.

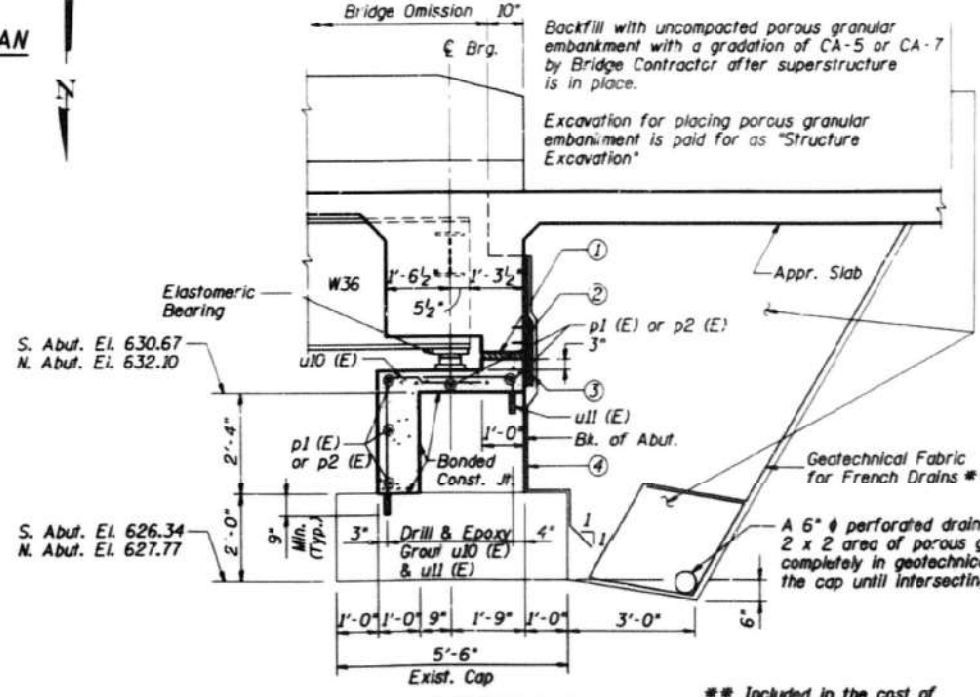

**SECTION A-A**

All dimensions at Rt. L

- Notes:**
- For Diaphragm Details & Reinf., see Sheet S7.
  - Remove 2" (Min.) of Top of bearing seats.
  - Rebuild new bearing seats to accommodate new bearings. Concrete Removal billed on Sheet S10.
  - Drilling and Epoxy Grouting is included in the cost of Reinforcement Bars, Epoxy Coated and shall be according to Sec. 584 of the Standard Specifications.
  - Space Reinforcement in Cap to miss anchor bolts.
  - Reinforcement Bars designat-d (E) shall be Epoxy Coated.

**SOUTH ABUTMENT MODIFICATIONS**

**WHEELER AVENUE  
OVER FAI-80  
STA. 349+62.75  
FAI ROUTE 80  
SECTION 99-348-1  
WILL COUNTY  
STRUCTURE NUMBER 099-0175**

Notavass, Wynn and Associates, Inc.  
ENGINEERS ARCHITECTS SURVEYORS  
205 WEST WACKER DRIVE  
CHICAGO, ILLINOIS 60606

DESIGNED	JM
CHECKED	EM
DRAWN	MR
CHECKED	EM

MODEL: Sheet  
FILE NAME: pw://transystems-pw.bentley.com/TRANSVSCORP-PW1-HOSTED/Projects/2018/CH401/40118002202-TransSystems/CAD/62R30/Sheets/23-Structural/099-8324/0998324-CR-03-040-ExistingPlan\_IX.dgn  
ROAD/STRUCTURAL/099/79/DDG/FILES/WHEASABUM.DGN



USER NAME =	DESIGNED - MK	REVISED -
PLOT SCALE =	CHECKED - DD	REVISED -
PLOT DATE =	DRAWN - MK	REVISED -
	CHECKED - DD	REVISED -

STATE OF ILLINOIS  
DEPARTMENT OF TRANSPORTATION

EXISTING PLANS - IX  
STRUCTURE NO. 099-0175

SHEET S-40 OF S-43 SHEETS

F.A.I. RTE.	SECTION	COUNTY	TOTAL SHEETS	SHEET NO.
80	FAI 80 21 STRUCTURE 9	WILL	130	97
ILLINOIS			FED. AID PROJECT	

ROUTE NO.	SECTION	COUNTY	TOTAL SHEETS	SHEET NO.	OF
F.A.I.-80	99-348-1	WILL	37	21	17 SHEETS
FED. ROAD DIST. NO.	ILLINOIS	FED. AID PROJECT-			

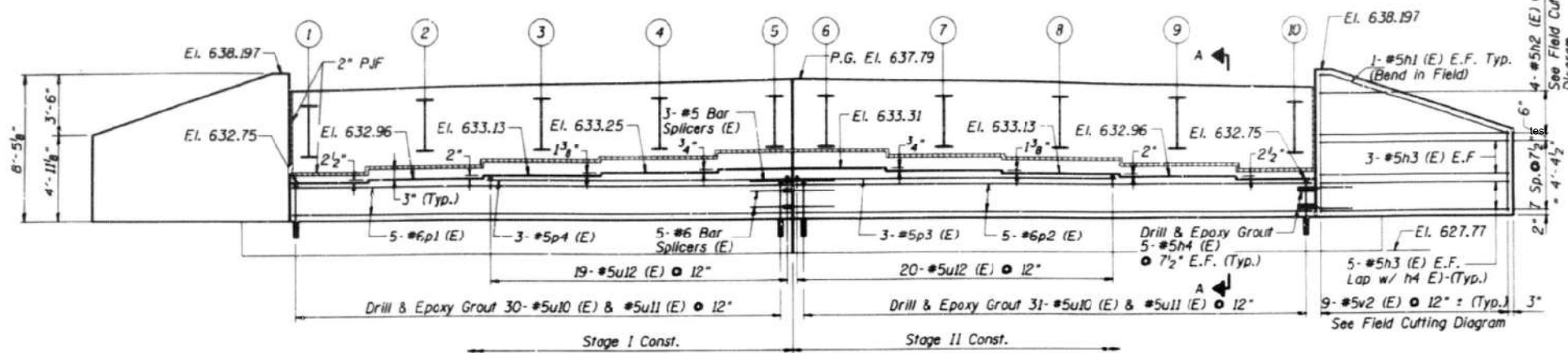

**ELEVATION**

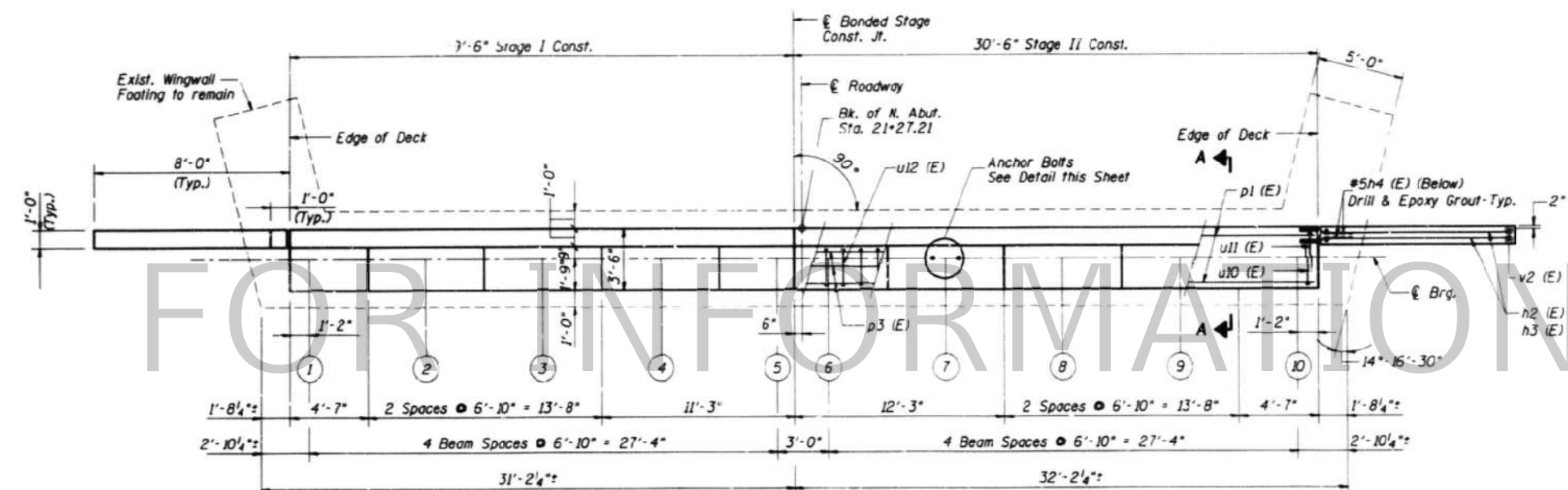

**PLAN**

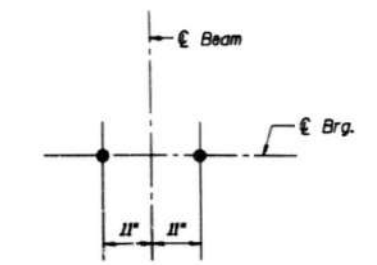

**ANCHOR BOLT LAYOUT**

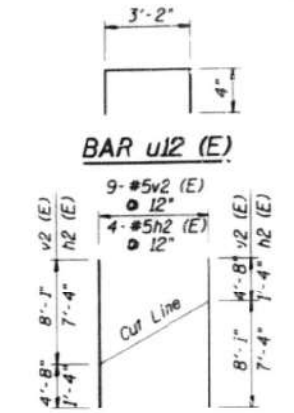

**FIELD CUTTING DIAGRAM**

Order v2 (E) and h2 (E) full length. Cut as shown and use remainder of bars in opposite face.

**BILL OF MATERIAL**

Bar	No.	Size	Length	Shape
h1 (E)	4	#5	8'-7"	
h2 (E)	8	#5	8'-8"	
h3 (E)	32	#5	7'-8"	
h4 (E)	20	#5	3'-0"	
p1 (E)	5	#6	29'-4"	
p2 (E)	5	#6	30'-4"	
p3 (E)	3	#5	18'-9"	
p4 (E)	3	#5	17'-9"	
u10 (E)	61	#5	5'-10"	
u11 (E)	61	#5	4'-3"	
u12 (E)	39	#5	3'-10"	
v2 (E)	18	#5	12'-9"	
Item	Unit	Total		
Reinforcement Bars, Epoxy Coated	Lbs.	2030		
Concrete Structures	Cu. Yd.	16.7		
Structure Excavation	Cu. Yd.	191		
Porous Granular Embankment	Cu. Yd.	180.0		
Bar Splicers	Each	8		

**Notes**

- For Diaphragm Details & Reinf., see Sheet S7.
- Remove 2" (Min.) of Top of bearing seats.
- Rebuild new bearing seats to accommodate new bearings. Concrete Removal billed on Sheet S10.
- Drilling and Epoxy Grouting is included in the cost of Reinforcement Bars, Epoxy Coated and shall be according to Sec. 584 of the Standard Specifications.
- Space Reinforcement in Cap to miss anchor bolts.
- Reinforcement Bars designated (E) shall be Epoxy Coated.
- For Section A-A, see Sheet S11.

**NORTH ABUTMENT MODIFICATIONS**

**WHEELER AVENUE  
OVER FAI-80  
STA. 349+62.75  
FAI ROUTE 80  
SECTION 99-348-1  
WILL COUNTY  
STRUCTURE NUMBER 099-0175**

Northwestern, Myrdal  
and Associates, Inc.  
ENGINEERS ARCHITECTS SURVEYORS  
208 WEST WACKER DRIVE  
CHICAGO, ILLINOIS 60609

DESIGNED	JM
CHECKED	EM
DRAWN	MR
CHECKED	EM

MODEL: Sheet  
FILE NAME: pw://transystems-pw.bentley.com:TRANSSYSTEMS\CAD\62R30\Sheets\2-Structural\099-8324\0998324-CR-03-041-ExistingPlan\_X.dgn  
8/10/2022 2:55:49 PM



USER NAME =	DESIGNED - MK	REVISED -
PLOT SCALE =	CHECKED - DD	REVISED -
PLOT DATE =	DRAWN - MK	REVISED -
	CHECKED - DD	REVISED -

**STATE OF ILLINOIS  
DEPARTMENT OF TRANSPORTATION**

**EXISTING PLANS - X  
STRUCTURE NO. 099-0175**

SHEET S-41 OF S-43 SHEETS

F.A.I. RTE.	SECTION	COUNTY	TOTAL SHEETS	SHEET NO.
80	FAI 80 21 STRUCTURE 9	WILL	130	98
CONTRACT NO. 62R30				
ILLINOIS FED. AID PROJECT				

ROUTE NO.	SECTION	COUNTY	TOTAL SHEETS	SHEET NO.	SHEET NO. OF
F.A.I. - 80	99-340-1	WILL	37	26	IT SHEETS
FED. ROAD DIST. NO. 7	ILLINOIS	FED. AID PROJECT -			

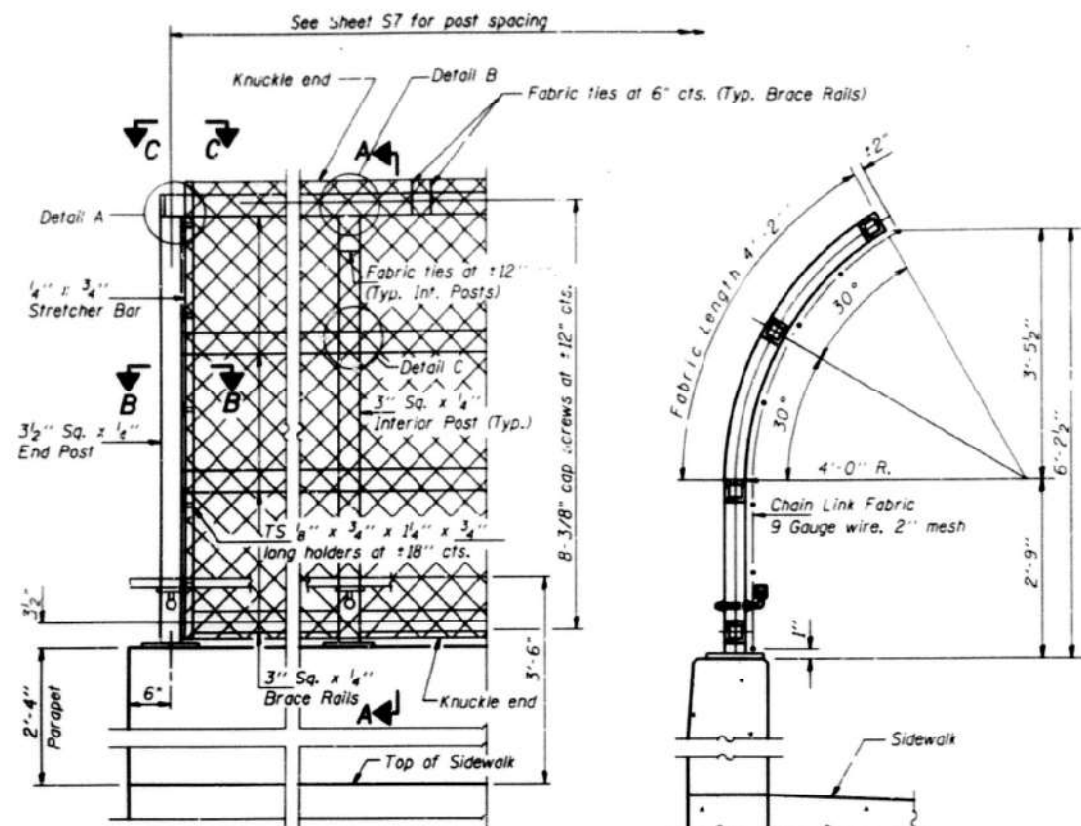

**ELEVATION**  
(Inside Face)

**SECTION A-A**

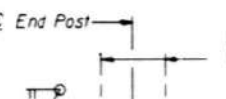

**DETAIL A**

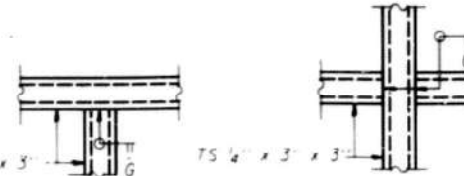

**DETAIL B**

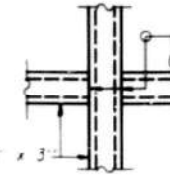

**DETAIL C**

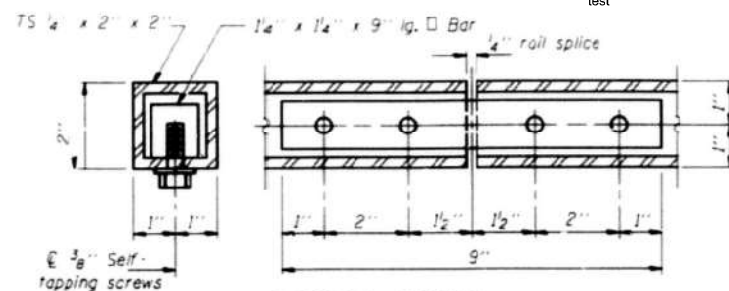

**HANDRAIL SPLICE**

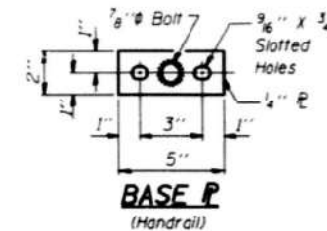

**BASE P**  
(Handrail)

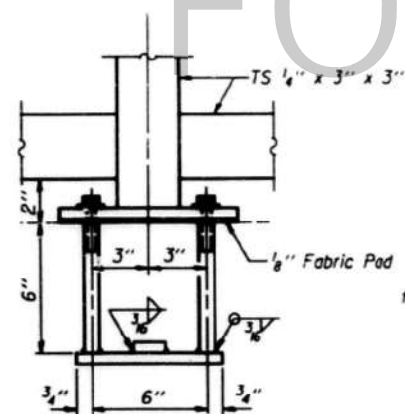

**ANCHOR BOLT DETAILS**

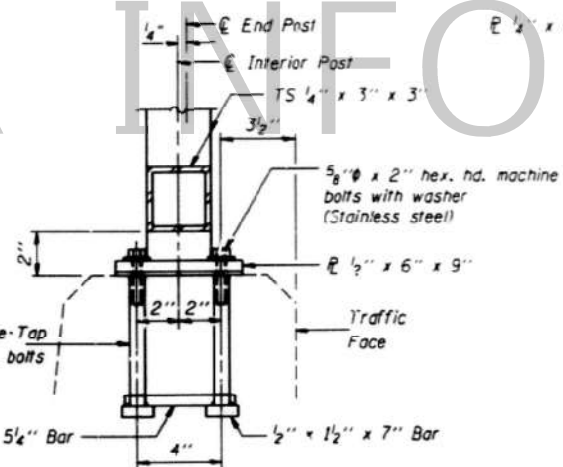

**BASE P**

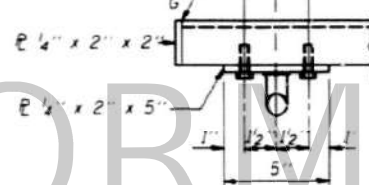

**HANDRAIL DETAIL**

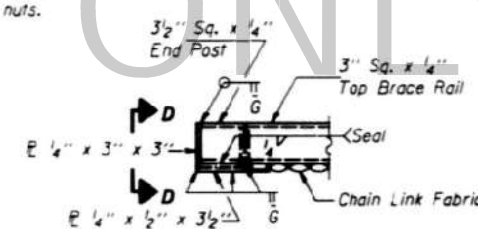
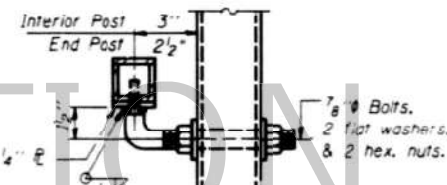

**VIEW C-C**

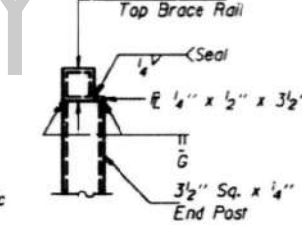

**VIEW D-D**

**BILL OF MATERIAL**

Item	Unit	Quantity
Bridge Fence Railing	Foot	475

**BRIDGE FENCE RAILING  
PARAPET MOUNTED**

**WHEELER AVENUE  
OVER FAI-80  
STA. 300+00.75  
EAL 099-0175  
SECTION 99-340-1**

**STRUCTURE NO. 099-0175**

DESIGNED	JK
CHECKED	EM
DRAWN	MR
DATE	

R-33 4-30-89

STATE OF ILLINOIS  
DEPARTMENT OF TRANSPORTATION

EXISTING PLANS - XI  
STRUCTURE NO. 099-0175

SHEET S-42 OF S-43 SHEETS

F.A.I. RTE.	SECTION	COUNTY	TOTAL SHEETS	SHEET NO.
80	FAI 80 21 STRUCTURE 9	WILL	130	99
			CONTRACT NO. 62R30	
			ILLINOIS FED. AID PROJECT	

**AECOM**  
303 EAST WACKER DRIVE, SUITE 1400  
CHICAGO, IL 60601-5274  
PHONE: (312) 373-1700 FAX: (312) 373-6800

ROUTE NO.	SECTION	COUNTY	TOTAL SHEETS	SHEET NO.
F.A.I. 80	99-348-1	WILL	17	27
FED. ROAD DIST. NO.	ILLINOIS	FED. AID PROJECT		

**BILL OF MATERIAL**  
(THIS SHEET ONLY)

Bar	No.	Size	Length	Shape
a10(E)	15	#4	23'-10"	---
a12(E)	52	#5	23'-10"	---
a12(E)	15	#4	24'-10"	---
a13(E)	52	#5	24'-10"	---
b10(E)	49	#5	29'-6"	---
b12(E)	99	#9	29'-6"	---
b12(E)	49	#5	19'-6"	---
b13(E)	99	#9	19'-6"	---
d10(E)	104	#4	2'-11"	---
h10(E)	2	#5	29'-6"	---
h12(E)	2	#5	19'-6"	---
i10(E)	48	#5	29'-4"	---
i12(E)	48	#5	30'-4"	---
w10(E)	124	#4	5'-8"	---
w12(E)	124	#4	6'-8"	---

NOTES:  
 For pay items and quantities see Roadway Plans.  
 Reinforcement bars designated (E) shall be epoxy coated.  
 Reinforcement bars, bar splicers, improved subgrade, sub-base, bond breaker and concrete pad (including reinforcement) will be included in the cost of "Bridge Approach Pavement (Special)".  
 See Standards 420401 and 609006 for details not shown.

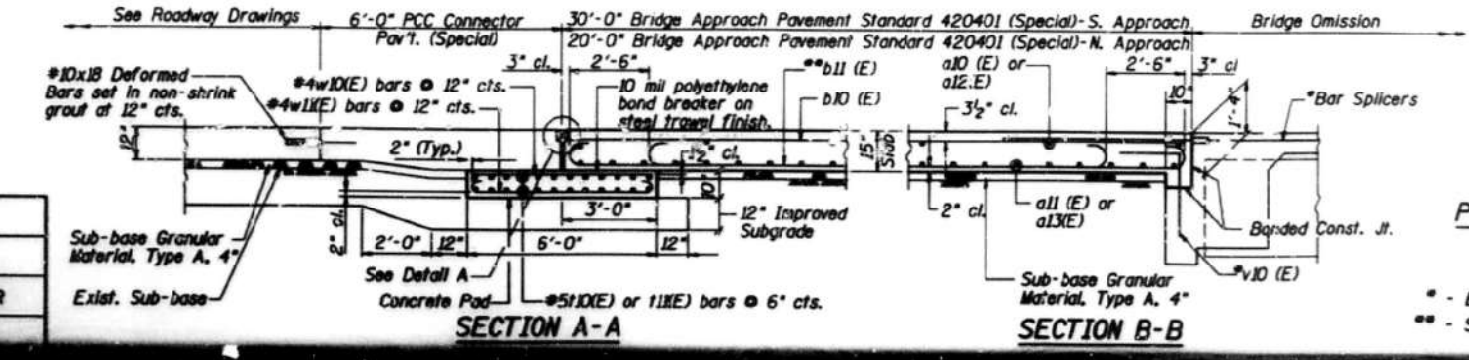
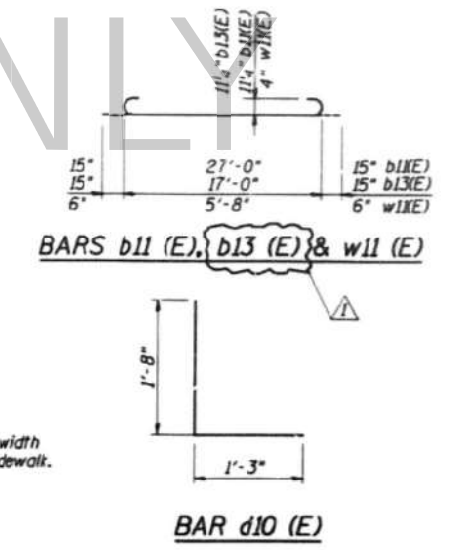
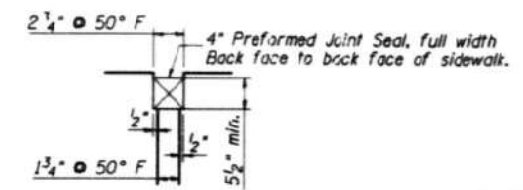
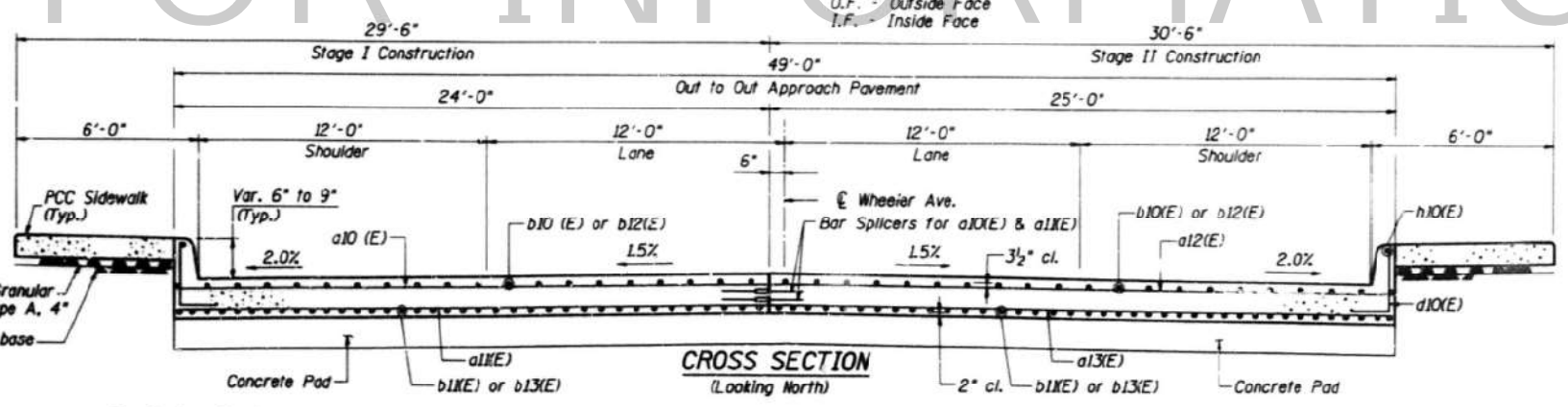
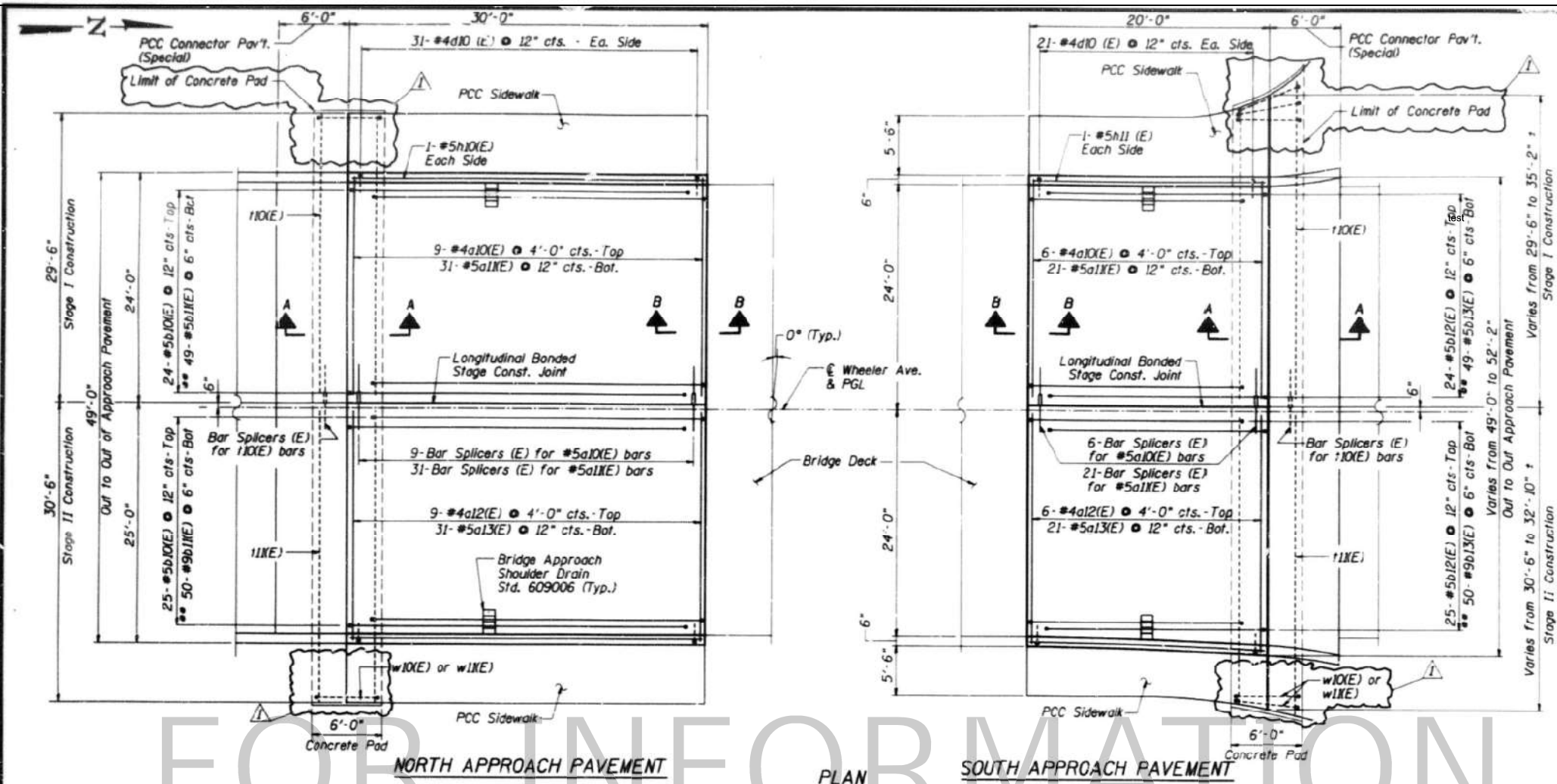

**BRIDGE APPROACH PAVEMENT (SPECIAL)**

**WHEELER AVENUE**  
**OVER FAI-80**  
**STA. 3+00.75**  
**FAI ROUTE 80**  
**SECTION 99-348-1**  
**WILL COUNTY**  
**STRUCTURE NUMBER 099-0175**

DESIGNED	JM
CHECKED	EC
DRAWN	JM/MR
CHECKED	EC

\* - Billed with Bridge Deck  
 \*\* - Stagger #3b11 (E) bars as shown on plan - full width.

MODEL: Sheet  
 FILE NAME: pw://transystems-pw.bentley.com/TRANSYS/COMP-PW1-HOSTED/Projects/2018/CH401/401-18002202-Transystems/CAD/628305/Sheets/23-Structural/099-8324/0998324-CR-03-04-3-ExistingPlan\_X11.dgn  
 CADD/STRUCTURAL/0998324/0998324-03-04-3-ExistingPlan\_X11.dgn  
 8/10/2022 2:56:46 PM



USER NAME =	DESIGNED - MK	REVISIONS -
PLOT SCALE =	CHECKED - DD	REVISIONS -
PLOT DATE =	DRAWN - MK	REVISIONS -
	CHECKED - DD	REVISIONS -

STATE OF ILLINOIS  
 DEPARTMENT OF TRANSPORTATION

EXISTING PLANS - XII  
 STRUCTURE NO. 099-0175

F.A.I. RTE.	SECTION	COUNTY	TOTAL SHEETS	SHEET NO.
80	FAI 80 21 STRUCTURE 9	WILL	130	100
			CONTRACT NO. 62R30	
		ILLINOIS	FED. AID PROJECT	