

STATE OF ILLINOIS  
DEPARTMENT OF TRANSPORTATION

F.A. RTE.	SECTION	COUNTY	TOTAL SHEETS	SHEET NO.
VAR.	2022 GUARDRAIL 01	VARIOUS	32	1
FED. ROAD DIST. NO.	ILLINOIS	CONTRACT NO. 62T90		

FOR INDEX OF SHEETS, SEE SHEET NO. 2

**PROPOSED  
HIGHWAY PLANS**

**ROUTE: VARIOUS EXPRESSWAYS AND ARTERIAL  
HIGHWAYS – DISTRICT ONE  
SECTION: 2022 GUARDRAIL 01  
GUARDRAIL REPAIRS  
VARIOUS COUNTIES  
C-91-314-22**

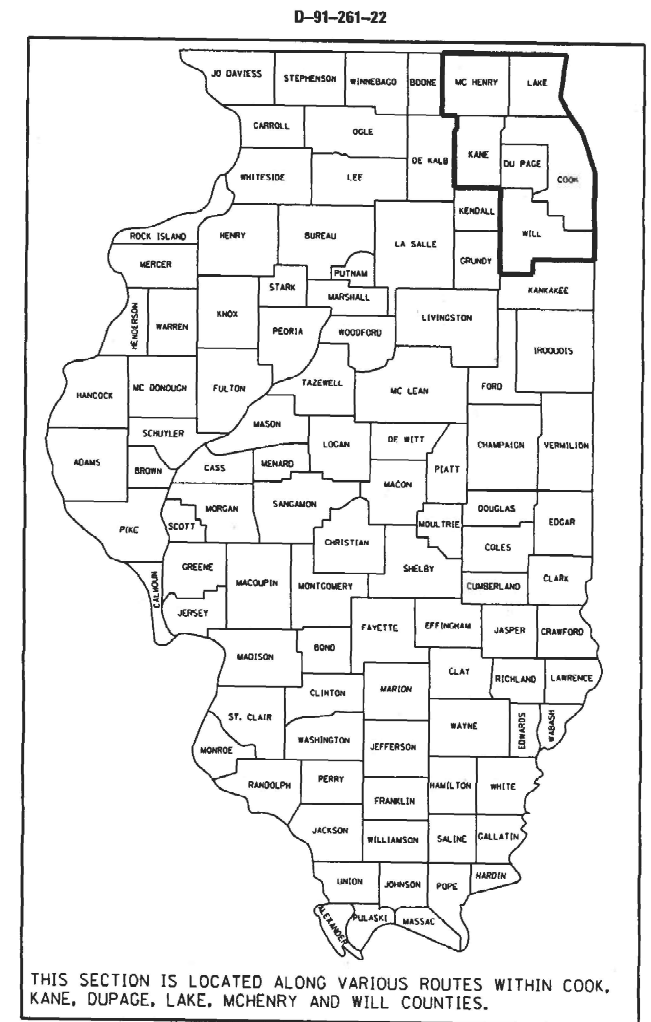

**SEE LOCATION MAPS  
SHEETS 5 THRU 13**

C.U.A.N.  
CHICAGO UTILITY ALERT NETWORK  
1-312-744-7000

J.U.L.I.E.  
JOINT UTILITY LOCATION INFORMATION FOR EXCAVATION  
1-800-892-0123  
OR 811

PROJECT ENGINEER: RODRIGO LEDEZMA (847) 705-4580  
PROJECT MANAGER: J. ALAIN MIDY (847) 221-3056  
CONTRACT NO. 62T90

STATE OF ILLINOIS  
DEPARTMENT OF TRANSPORTATION

SUBMITTED June 30 20 22  
Open Pits 1008  
REGIONAL ENGINEER

October 14, 2022  
[Signature]  
ENGINEER OF DESIGN AND ENVIRONMENT

October 14, 2022  
[Signature]  
DIRECTOR OF HIGHWAYS PROJECT IMPLEMENTATION

**PRINTED BY THE AUTHORITY  
OF THE STATE OF ILLINOIS**

**INDEX OF SHEETS**

**LIST OF STATE STANDARDS**

**GENERAL NOTES**

1	COVERSHEET
2	INDEX OF SHEETS, STANDARDS, AND GENERAL NOTES
3 - 4	SUMMARY OF QUANTITIES
5	McHENRY COUYNTY LOCATION MAP
6	LAKE COUNTY LOCATION MAP
7	NORTH KANE COUNTY LOCATION MAP
8	NORTH DU PAGE COUNTY LOCATION MAP
9	NORTH COOK COUNTY LOCATION MAP
10	SOUTH COOK COUNTY LOCATION MAP
11	SOUTH KANE COUNTY LOCATION MAP
12	SOUTH DU PAGE COUNTY LOCATION MAP
13	WILL COUNTY LOCATION MAP
14	TYPICAL DETAIL TO ANCHOR STEEL PLATE BEAM GUARD RAIL ON CONCRETE (BM-02)
15	TYPICAL DETAIL FOR GUARDRAIL ANCHOR BLOCK REPAIR (BM-03)
16	TYPICAL DETAILS FOR STEEL PLATE BEAM GUARDRAIL ANCHORAGE REPAIR (BM-04)
17	DETAIL FOR CENTER LONGITUDINAL GUARDRAIL JOINT (BM-05)
18	DETAIL OF STEEL PLATE BEAM GUARDRAIL SPECIAL (BM-06)
19	DETAIL OF GUARDRAIL SUPPORT AND END ANCHORAGE (BM-07)
20	DETAIL OF THRIE-BEAM GUARDRAIL WITH MODIFIED OFFSET BLOCK
21	STEEL PLATE BEAM GUARDRAIL STEEL BLOCK-OUT DETAIL
22	CURB REMOVAL (PARTIAL) AND SHOULDER WIDENING FOR TRAFFIC BARRIER TERMINAL ,TYPE 1 SPECIAL
23	STEEL BRIDGE RAIL DETAIL
24	T6 TERMINAL FOR USE WITH 21" HIGH SPBGR (BM-22)
25 - 27	ENTRANCE AND EXIT RAMP CLOSURE DETAILS (TC-08)
28	TRAFFIC CONTROL DETAILS FOR FREEWAY SINGLE AND MULTI-LANE WEAVE TC-09)
29	TRAFFIC CONTROL AND PROTECTION FOR SIDE ROADS, INTERSECTIONS AND DRIVEWAYS (TC-10)
30	TRAFFIC CONTROL AND PROTECTION AT TURN BAYS (TC-14)
31	TRAFFIC CONTROL DETAIL FOR SHOULDER CLOSURE AND PARTIAL RAMP CLOSURES (TC-17)
32	SIGNING FOR FLAGGING OPERATIONS AT WORK ZONEOPENINGS (TC-18)

630001 - 12	STEEL PLATE BEAM GUARDRAIL
630301 - 09	SHOULDER WIDENING FOR TYPE 1 (SPECIAL) GUARDRAIL TERMINALS
631006 - 08	TRAFFIC BARRIER TERMINAL, TYPE 1B
631011 - 10	TRAFFIC BARRIER TERMINAL, TYPE 2
631026 - 06	TRAFFIC BARRIER TERMINAL, TYPE 5
631031 - 17	TRAFFIC BARRIER TERMINAL, TYPE 6
701006 - 05	OFF-RD OPERATIONS, 2L, 2W, 15' TO 24" FROM PAVEMENT EDGE
701011 - 04	OFF-RD MOVING OPERATIONS, 2L, 2W, DAY ONLY
701101 - 05	OFF-RD OPERATIONS, MULTILANE, 15' TO 24" FROM PAVEMENT EDGE
701106 - 02	OFF-RD OPERATIONS, MULTILANE, > 15' AWAY
701201 - 05	LANE CLOSURE, 2L, 2W, DAY ONLY, FOR SPEEDS > 45 MPH
701301 - 04	LANE CLOSURE, 2L, 2W, SHORT TIME OPERATIONS
701311 - 03	LANE CLOSURE, 2L, 2W, MOVING OPERATIONS, DAY ONLY
701336 - 07	LANE CLOSURE, 2L, 2W, WORK AREAS IN SERIES, FOR SPEEDS > 45 MPH
701400 - 11	APPROACH TO LANE CLOSURE, FREEWAY/ EXPRESSWAY
701401 - 13	LANE CLOSURE, FREEWAY/ EXPRESSWAY
701411 - 09	LANE CLOSURE, MULTILANE, AT ENTRANCE OR EXIT RAMP, FOR SPEED > 45 MPH
701421 - 08	LANE CLOSURE, MULTILANE, DAY OPERATIONS ONLY FOR SPEEDS > 45 MPH TO 55 MPH
*701426 - 09	LANE CLOSURE, MULTILANE, INTERMITTENT OR MOVING OPERATIONS, FOR SPEEDS > 45 MPH
701427 - 05	LANE CLOSURE, MULTILANE, INTERMITTANT OR MOVING OPERATIONS < 40 MPH
701428 - 01	TRAFFIC CONTROL SETUP AND REMOVAL FREEWAY/EXPRESSWAY
701501 - 06	URBAN LANE CLOSURE, 2L, 2W, UNDIVIDED
701502 - 09	URBAN LANE CLOSURE, 2L, 2W, WITH BIDIRECTIONAL LEFT TURN LANE
701601 - 09	URBAN LANE CLOSURE, MULTILANE, 1W OR 2W, WITH NONTRAVERSABLE MEDIAN
701606 - 10	URBAN LANE CLOSURE, MULTILANE, 2W WITH MOUNTABLE MEDIAN
701701 - 10	URBAN LANE CLOSURE, MULTILANE INTERSECTION
701801 - 06	LANE CLOSURE MULTILANE 1W OR 2W CROSSWALK OR SIDEWALK CLOSURE
701901 - 08	TRAFFIC CONTROL DEVICES
720011 - 01	METAL POSTS FOR SIGNS, MARKERS & DELINEATORS
782006 - 01	GUARDRAIL & BARRIER WALL REFLECTOR MOUNTING DETAILS

1. BEFORE STARTING ANY EXCAVATION, THE CONTRACTOR SHALL CALL "JULIE" AT (800) 892-0123 OR 811 OR "CUAN" AT (312) 744-700 FOR FIELD LOCATIONS OF BURIED ELECTRIC, TELEPHONE AND GAS UTILITIES. 48 HOUR NOTIFICATION IS REQUIRED.
2. ALL WORK IS TO BE REPLACED IN KIND OR AS INDICATED ON THE CONTRACT QUANTITY SHEET. GUARDRAIL WORK WILL INCLUDE ALIGNMENT AS NECESSARY TO RESTORE THE RAIL TO THE ORIGINAL CONDITIONS.
3. REMOVAL OF DAMAGED MATERIALS WILL INCLUDE DISMANTLING, LOADING, HAULING AND DISPOSAL. THE WORK SITE WILL BE LEFT IN A SAFE AND ORDERLY CONDITION.
4. NO MATERIAL SHOULD BE LEFT ON OR NEAR THE ROADWAY DURING NON-WORKING HOURS.
5. ANY NECESSARY TRAFFIC CONTROL WILL BE PROVIDED BY THE CONTRACTOR; APPROPRIATE STANDARDS ARE HEREWITH ATTACHED.
6. THE LIMITS OF THE DAMAGED GUARDRAIL WILL BE MARKED WITH PAINT. THE REPLACEMENT PARTS AND THE QUANTITIES INDICATED ARE WITHIN THESE LIMITS AS MARKED.
7. REMOVED GUARDRAIL THAT IS NOT REPLACED ON THE SAME DAY MUST BE DELINEATED WITH LIGHTED BARRICADES. NO LOCATIONS WILL BE LEFT WITHOUT EITHER LIGHTED BARRICADES OR RESTORED GUARDRAIL AT ANY TIME.
8. GUARDRAIL MARKERS SHALL NOT BE ATTACHED TO TERMINAL SECTIONS.
9. THE CONTRACTOR SHALL TELEPHONE THE IDOT BUREAU OF TRAFFIC OPERATIONS, ELECTRICAL MAINTENANCE SECTION AT 708-524-2145 TO REQUEST THE LOCATE FOR UNDERGROUND ELECTRICAL AND/OR FIBER CABLE PRIOR TO ANY DIGGING AS PER THE CONTRACT.
10. REMOVAL OF EXISTING TERMINAL SECTIONS INCLUDED IN COST OF NEW TERMINAL SECTIONS
11. THE CONTRACTOR SHALL SUBMIT ALL DAILY LANE, RAMP AND SHOULDER CLOSURES VIA WWW.IDOTLCS.COM AT LEAST 24 HOURS IN ADVANCE OF ALL DAILY LANE, AND RAMP AND SHOULDER CLOSURES. THE CONTRACTOR SHALL REQUEST AND GAIN THE APPROVAL FROM THE ILLINOIS DEPARTMENT OF TRANSPORTATION'S EXPRESSWAY TRAFFIC OPERATIONS ENGINEER AT (847) 705-4151 OR (847) 705-4155.
12. THE CONTRACTOR SHALL CONTACT THE TRAFFIC CONTROL SUPERVISOR AT KALPANA.KANNAN-HOSADURGA@ILLINOIS.GOV A MINIMUM OF 72 HOURS IN ADVANCE OF BEGINNING WORK.

\* MOVING LANE CLOSURES NOT PERMITTED ON EXPRESSWAYS

FILE NAME =	USER NAME = Rodrigo.Ledezma	DESIGNED -	REVISED -	<b>STATE OF ILLINOIS DEPARTMENT OF TRANSPORTATION</b>	<b>INDEX OF SHEETS, STATE STANDARDS AND GENERAL NOTES</b>			F.A. RTE.	SECTION	COUNTY	TOTAL SHEETS	SHEET NO.
pw:\idot-pw\bentley.com\PWIDOT\Documents\IDOT Offices\District 1\Projects\0126122\CAD\DRAWING\0126122-sht-gennote.dgn	PLotted SCALE = 100.0000' / in.	CHECKED -	REVISED -					VAR.	2022 GUARDRAIL 01	VARIOUS	32	2
	PLotted DATE = 7/7/2022	DATE -	REVISED -		SCALE: SHEET NO. OF SHEETS STA. TO STA.			FED. ROAD DIST. NO. ILLINOIS FED. AID PROJECT				
								<b>CONTRACT NO. 62T90</b>				

SUMMARY OF QUANTITIES			TOTAL QUANTITIES URBAN	CONSTRUCTION TYPE CODE					SUMMARY OF QUANTITIES			TOTAL QUANTITIES URBAN	CONSTRUCTION TYPE CODE						
CODE NO	ITEM	UNIT		100% STATE 0021	100% STATE MCHD 0021					CODE NO	ITEM		UNIT	100% STATE 0021	100% STATE MCHD 0021				
63000001	STEEL PLATE BEAM GUARDRAIL, TYPE A, 6	FOOT	386	309	77					X4402302	CURB REMOVAL (PARTIAL)	FOOT	149	119	30				
	FOOT POSTS																		
* 63100041	TRAFFIC BARRIER TERMINAL, TYPE 1B	EACH	3	2	1					X6300210	GUARDRAIL BLOCKS	EACH	1631	1305	326				
* 63100045	TRAFFIC BARRIER TERMINAL, TYPE 2	EACH	11	9	2					X6300215	RAIL ELEMENT PLATES	EACH	2078	1662	416				
* 63100070	TRAFFIC BARRIER TERMINAL, TYPE 5	EACH	3	2	1					X6300217	RAIL ELEMENT PLATES (RADIUS)	EACH	2078	1662	416				
* 63100085	TRAFFIC BARRIER TERMINAL, TYPE 6	EACH	6	5	1					X6300222	CONNECTING END SECTION	EACH	111	89	22				
* 63100167	TRAFFIC BARRIER TERMINAL, TYPE 1 (SPECIAL) TANGENT	EACH	62	50	12					X6300224	RETURN END SECTION	EACH	3	2	1				
* 63100169	TRAFFIC BARRIER TERMINAL, TYPE 1 (SPECIAL) FLARED	EACH	10	8	2					X6300225	SINGLE END SECTION	EACH	17	14	3				
* 72501000	TERMINAL MARKER - DIRECT APPLIED	EACH	506	405	101					X6300230	STEEL POSTS	EACH	1262	1010	252				
* 78200005	GUARDRAIL REFLECTORS, TYPE A	EACH	23	18	5					X6300310	REMOVE AND REPLACE GUARDRAIL CHANNEL	EACH	66	53	13				
* X0321563	REPAIR TRAFFIC BARRIER TERMINAL TYPE 1 SPECIAL	EACH	322	258	64					X6300610	THRIE BEAM GUARDRAIL ELEMENT PLATES	EACH	7	6	1				
X2300001	MISSING OR FAILED ANCHOR CABLES	EACH	16	13	3					X6300620	THRIE-BEAM MODIFIED BLOCKS	EACH	7	6	1				
X2300002	MISSING OR FAILED LAG BOLTS	EACH	16	13	3				* X6310163	TRAFFIC BARRIER TERMINAL, TYPE 1, NOSE	EACH	10	8	2					
X2300019	REATTACHING AND REALIGNING TERMINALS AND RAIL ELEMENT PLATES	EACH	32	26	6				* X6310177	TRAFFIC BARRIER TERMINAL, TYPE 3 (SPECIAL)	EACH	4	3	1					

FILE NAME =	USER NAME = <i>RodrigoLedeza</i>	DESIGNED -	REVISED -
<i>pw:\11dot-pw.bentley.com\PW\DOT\Documents\1007 - Office\District 1\Projects\DI26122\CAD\Drawings\Design\DI26122-shr-5000</i>	DRAWN -	CHECKED -	REVISED -
	PLOT SCALE = 100.0000 "/>	DATE -	REVISED -
	PLOT DATE = 7/7/2022		

**STATE OF ILLINOIS  
DEPARTMENT OF TRANSPORTATION**

<b>SUMMARY OF QUANTITIES</b>			
SCALE:	SHEET NO.	OF SHEETS	STA. TO STA.

F.A. RTE.	SECTION	COUNTY	TOTAL SHEETS	SHEET NO.
VAR	2022 GUARDRAIL 01	VARIOUS	32	3
CONTRACT NO. 62T90				
FED. ROAD DIST. NO. 1   ILLINOIS   FED. AID PROJECT				

\* SPECIALTY ITEM

REV-SEP



SUMMARY OF QUANTITIES				CONSTRUCTION TYPE CODE					SUMMARY OF QUANTITIES				CONSTRUCTION TYPE CODE						
CODE NO	ITEM	UNIT	TOTAL QUANTITIES URBAN	100% STATE 0021	100% STATE MCHD 0021					CODE NO	ITEM	UNIT	TOTAL QUANTITIES URBAN	100% STATE 0021	100% STATE MCHD 0021				
* X6310203	TRAFFIC BARRIER TERMINAL, TYPE 3 SPECIAL, NOSE	EACH	3	2	1					* Z0052600	REPAIR TRAFFIC BARRIER TERMINAL, TYPE 2	EACH	35	28	7				
X6330800	GUARDRAIL POST VERTICAL ADJUSTMENT	EACH	23	18	5					* Z0052900	REPAIR TRAFFIC BARRIER TERMINAL, TYPE 4	EACH	4	3	1				
X6331105	STEEL POSTS, MODIFIED	EACH	29	23	6					* Z0053000	REPAIR TRAFFIC BARRIER TERMINAL, TYPE 5	EACH	4	3	1				
X6331110	STEEL POSTS, SPECIAL	EACH	18	14	4					* Z0053200	REPAIR TRAFFIC BARRIER TERMINAL, TYPE 6	EACH	5	4	1				
Z0007124	STEEL RAILING (SPECIAL)	FOOT	55	44	11					* Z0059660	REPAIR TRAFFIC BARRIER TERMINAL TYPE 1 SPECIAL - RAIL ELEMENT PLATE	EACH	117	94	23				
* Z0029656	REPAIR TRAFFIC BARRIER TERMINAL TYPE 3 SPECIAL	EACH	9	7	2					Z0078000	WOOD RAIL	FOOT	360	288	72				
* Z0029658	REPAIR TRAFFIC BARRIER TERMINAL TYPE 1 SPECIAL - POST	EACH	405	324	81														
Z0051400	REMOVING AND RESETTNG POSTS	EACH	75	60	15														
Z0052100	REPAIR STEEL PLATE BEAM GUARDRAIL, TYPE B	FOOT	170	136	34														
Z0052200	REPAIR STEEL PLATE BEAM GUARDRAIL, TYPE C	FOOT	75	60	15														
* Z0052400	REPAIR TRAFFIC BARRIER TERMINAL, TYPE 1	EACH	9	7	2														
* Z0052550	REPAIR TRAFFIC BARRIER TERMINAL, TYPE 1B	EACH	3	2	1														

FILE NAME =	USER NAME = <i>RodrigoLedezma</i>	DESIGNED -	REVISED -	<b>STATE OF ILLINOIS DEPARTMENT OF TRANSPORTATION</b>	<b>SUMMARY OF QUANTITIES</b>	F.A. RTE.	SECTION	COUNTY	TOTAL SHEETS	SHEET NO.
pw:\11dot-pw.bentley.com\PW\DOT\Documents\11DOT_Offices\District 1\Projects\DI26122\CAD\Drawn\Design\DI26122-shr-SC0001.DWG	DRAWN -	REVISED -	VAR			2022 GUARDRAIL 01	VARIOUS	32	4	
PLOT SCALE = 100.0000' / 1in.	CHECKED -	REVISED -	CONTRACT NO. 62T90							
PLOT DATE = 7/7/2022	DATE -	REVISED -	FED. ROAD DIST. NO. 1   ILLINOIS FED. AID PROJECT							
SCALE:		SHEET NO. OF SHEETS		STA. TO STA.						

\* SPECIALTY ITEM

REV-SEP



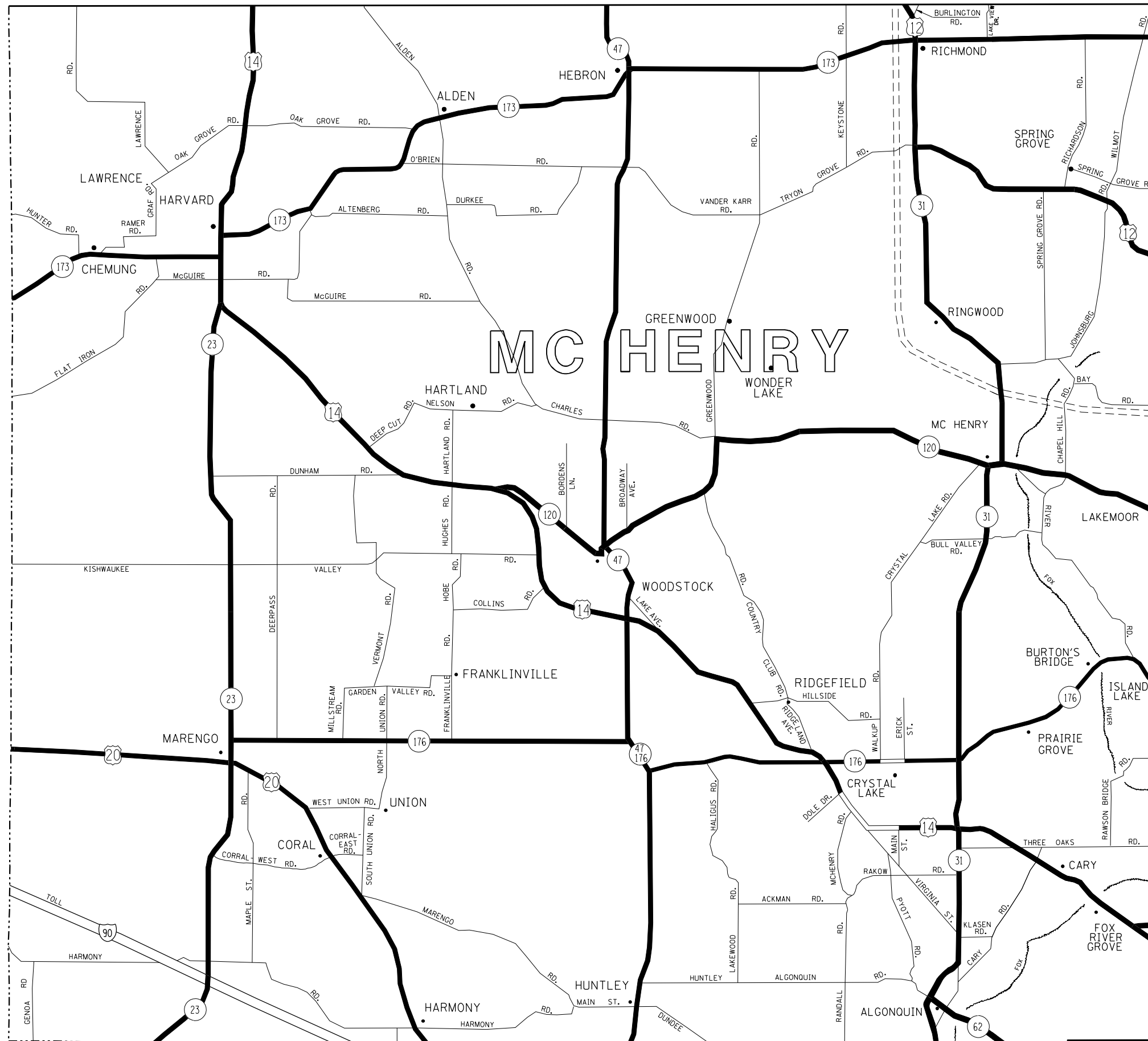

**DISTRICT NO. 1**

- STATE HIGHWAYS & EXPRESSWAYS WITHIN STATE JURISDICTION. (EXCEPT TOLLWAYS) AND CITY MAINTENANCE AGREEMENTS UNDER STATE JURISDICTION**
- FUTURE HIGHWAYS**
- VARIOUS AGENCIES HIGHWAYS**

FILE NAME :	USER NAME = Rodrigo.Ledezma	DESIGNED -	REVISED -
p:\dot-pw\bentley.com\PWIDOT\Documents\DOT Offices\District 1\Projects\0126122\CAD\DRAWING\0126122-sht-plan.dgn		REVISOR -	REVISION -
	PLOT SCALE = 100.0000' / 1" =	CHECKED -	REVISED -
	PLOT DATE = 7/7/2022	DATE -	REVISED -

**STATE OF ILLINOIS  
DEPARTMENT OF TRANSPORTATION**

<b>GUARDRAIL REPAIR LOCATION MAP</b>			
<b>McHENRY COUNTY</b>			
SCALE:	SHEET NO.	OF SHEETS	STA. TO STA.

F.A. RTE.	SECTION	COUNTY	TOTAL SHEETS	SHEET NO.
VAR.	2022 GUARDRAIL 01	VARIOUS	32	5
			CONTRACT NO. 62T90	
FED. ROAD DIST. NO.		ILLINOIS FED. AID PROJECT		

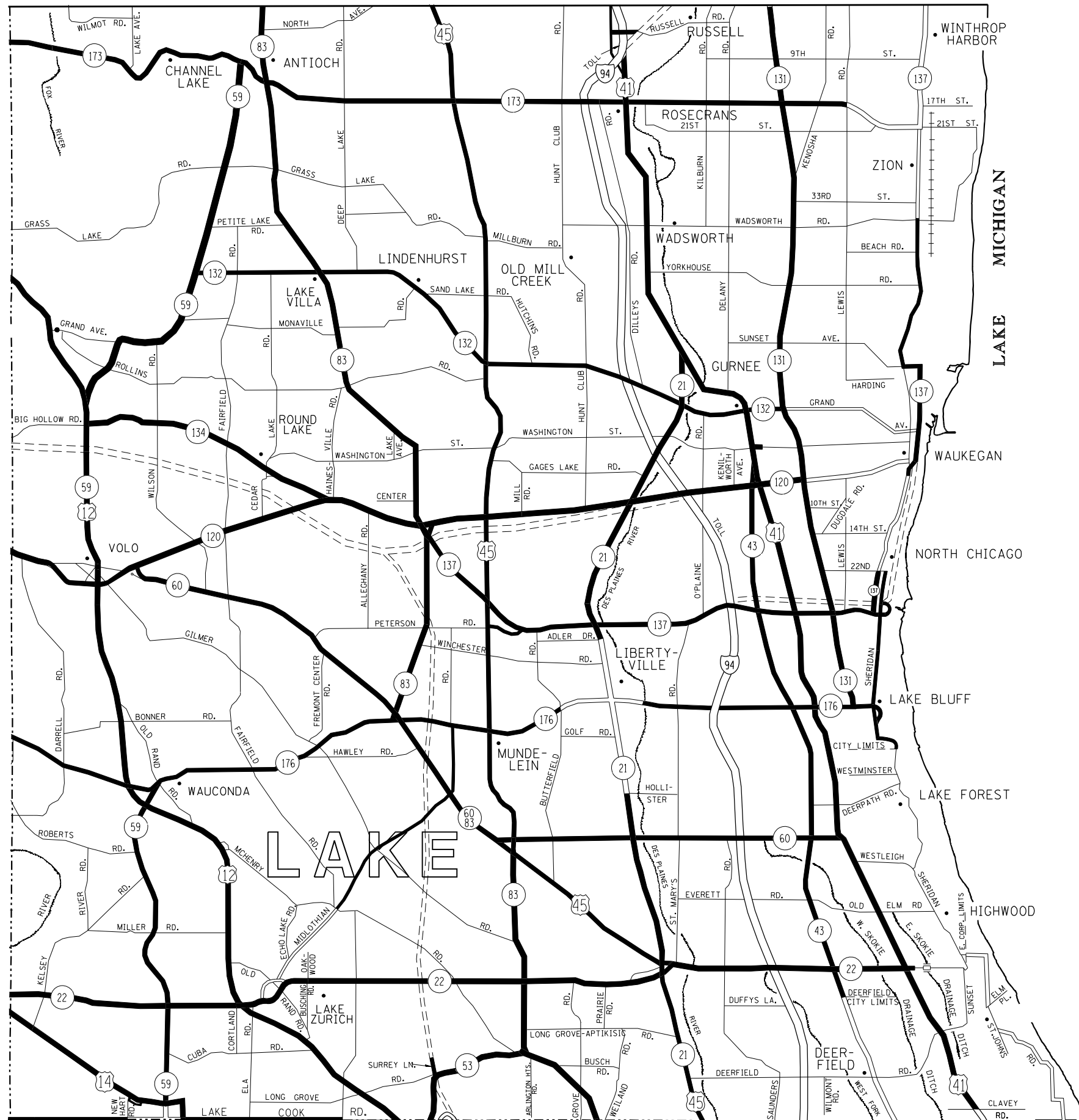

**DISTRICT NO. 1**

- STATE HIGHWAYS & EXPRESSWAYS WITHIN STATE JURISDICTION. (EXCEPT TOLLWAYS) AND CITY MAINTENANCE AGREEMENTS UNDER STATE JURISDICTION**
- FUTURE HIGHWAYS**
- VARIOUS AGENCIES HIGHWAYS**

FILE NAME =	USER NAME = Rodrigo.Ledezma	DESIGNED -	REVISED -
p:\1\1dot-pw.bentley.com\PWIDOT\Documents\1\DOT\Offices\District 1\Projects\0126122\CADD\Drawings\0126122-sht-plan.dgn		CHECKED -	REVISED -
		DATE -	REVISED -

**STATE OF ILLINOIS  
DEPARTMENT OF TRANSPORTATION**



**GUARDRAIL REPAIR LOCATION MAP  
LAKE COUNTY**

SCALE: SHEET NO. OF SHEETS STA. TO STA.

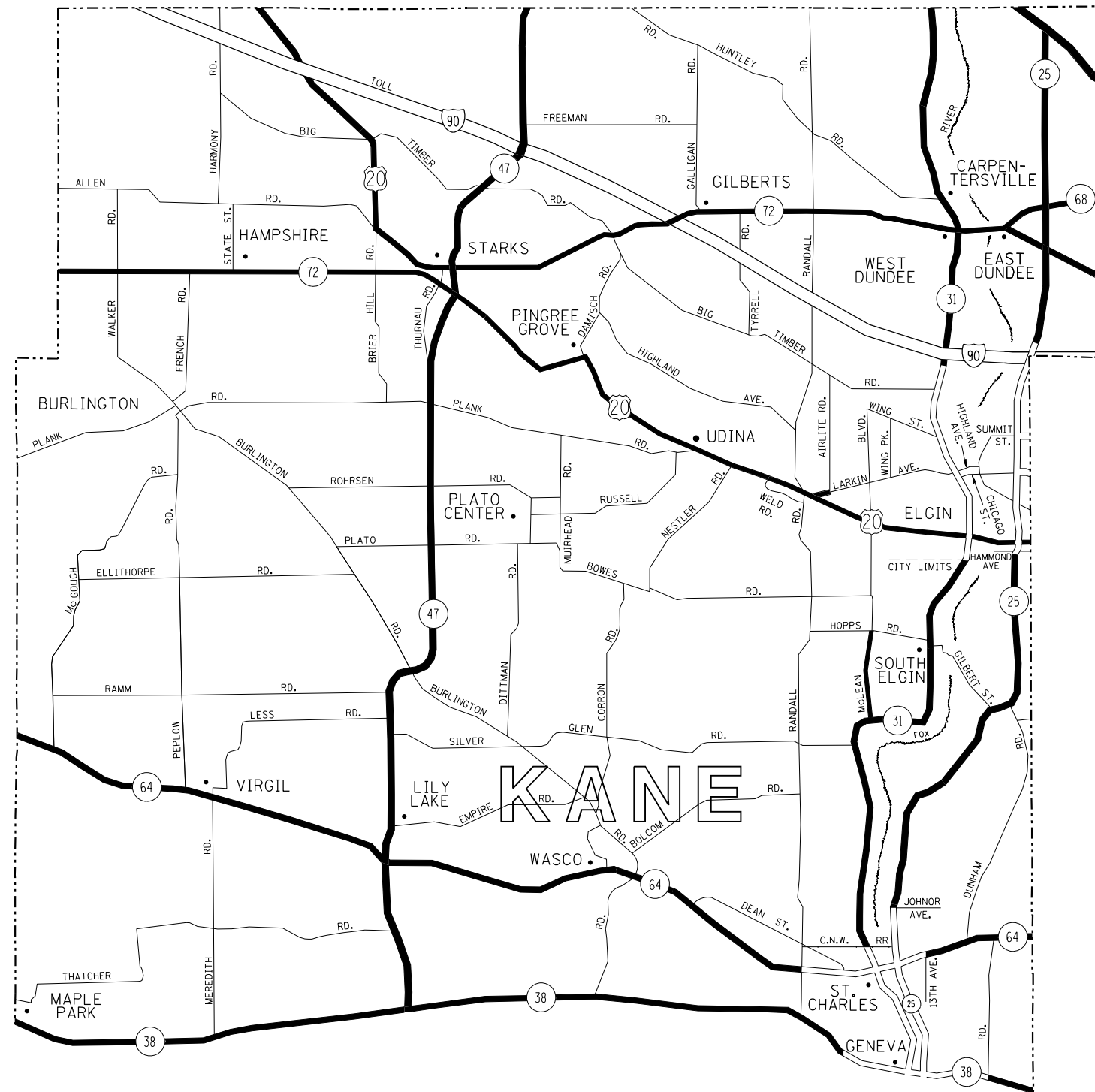
F.A. RTE.	SECTION	COUNTY	TOTAL SHEETS	SHEET NO.
VAR.	2022 GUARDRAIL 01	VARIOUS	32	6
			CONTRACT NO. 62T90	
FED. ROAD DIST. NO.		ILLINOIS FED. AID PROJECT		



**DISTRICT NO. 1**

-  STATE HIGHWAYS & EXPRESSWAYS WITHIN STATE JURISDICTION. (EXCEPT TOLLWAYS) AND CITY MAINTENANCE AGREEMENTS UNDER STATE JURISDICTION
-  FUTURE HIGHWAYS
-  VARIOUS AGENCIES HIGHWAYS

FILE NAME =	USER NAME = Rodrigo.Ledezma	DESIGNED -	REVISED -
p:\1\dot-pw.bentley.com\PWIDOT\Documents\1\DOT Offices\District 1\Projects\0126122\CAD\DRAWING\0126122-sht-plan.dgn		CHECKED -	REVISED -
		DATE -	REVISED -

**STATE OF ILLINOIS  
DEPARTMENT OF TRANSPORTATION**

**GUARDRAIL REPAIR LOCATION MAP KANE COUNTY  
NORTH OF AND INCLUDING IL RTE 38**

SCALE: SHEET NO. OF SHEETS STA. TO STA.

F.A. RTE.	SECTION	COUNTY	TOTAL SHEETS	SHEET NO.
VAR.	2022 GUARDRAIL 01	VARIOUS	32	7
			CONTRACT NO. 62T90	
FED. ROAD DIST. NO.		ILLINOIS FED. AID PROJECT		



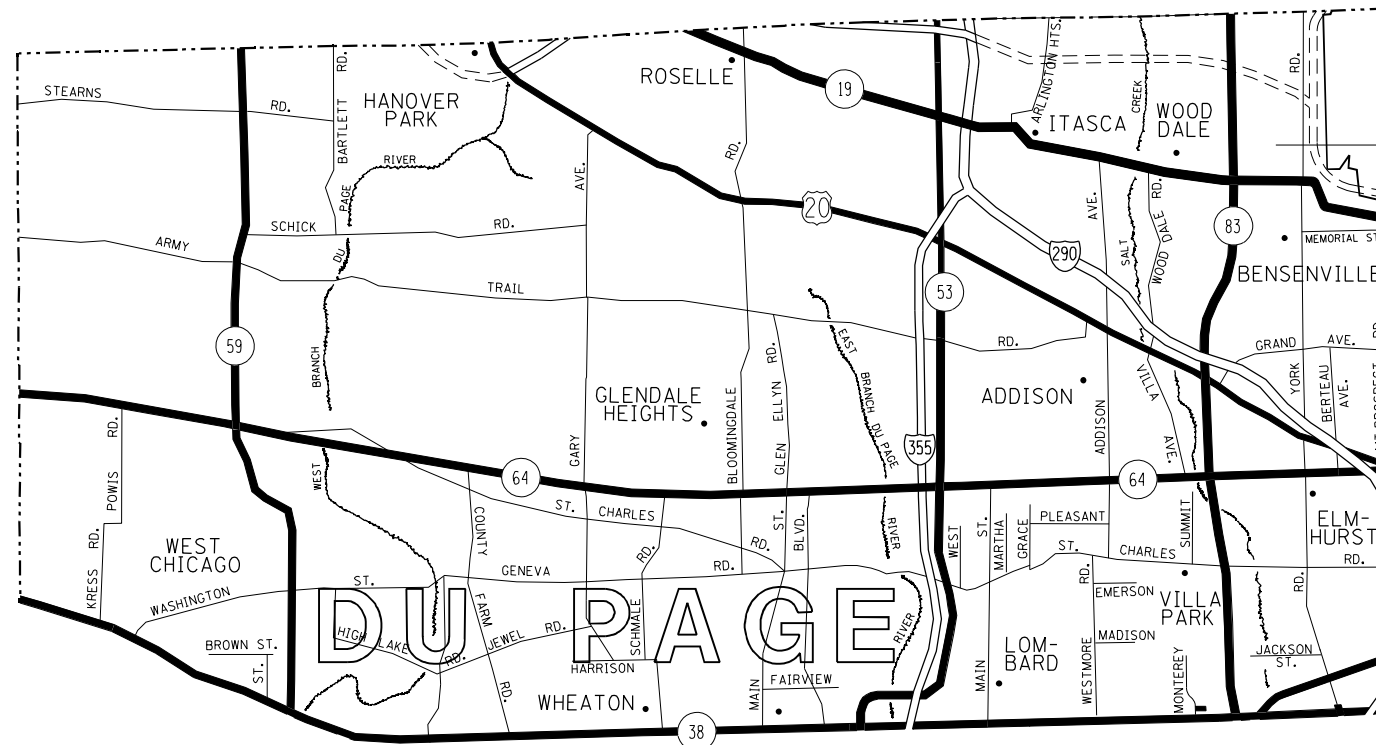

**DISTRICT NO. 1**

- STATE HIGHWAYS & EXPRESSWAYS WITHIN STATE JURISDICTION. (EXCEPT TOLLWAYS) AND CITY MAINTENANCE AGREEMENTS UNDER STATE JURISDICTION
- FUTURE HIGHWAYS
- VARIOUS AGENCIES HIGHWAYS

FILE NAME =	USER NAME = Rodrigo.Ledezma	DESIGNED -	REVISED -
p:\11dot-pw.bentley.com\PWIDOT\Documents\11DOT Offices\District 1\Projects\0126122\CAD\DRAWING\0126122-sht-plan.dgn		DRAWN -	REVISED -
	PLOT SCALE = 100.0000' / in.	CHECKED -	REVISED -
	PLOT DATE = 7/7/2022	DATE -	REVISED -

**STATE OF ILLINOIS  
DEPARTMENT OF TRANSPORTATION**

**GUARDRAIL REPAIR LOCATION MAP DuPAGE COUNTY  
NORTH OF AND INCLUDING IL RTE 38**

SCALE: SHEET NO. OF SHEETS STA. TO STA.

F.A. RTE.	SECTION	COUNTY	TOTAL SHEETS	SHEET NO.
VAR.	2022 GUARDRAIL 01	VARIOUS	32	8
			CONTRACT NO. 62T90	
FED. ROAD DIST. NO.		ILLINOIS FED. AID PROJECT		

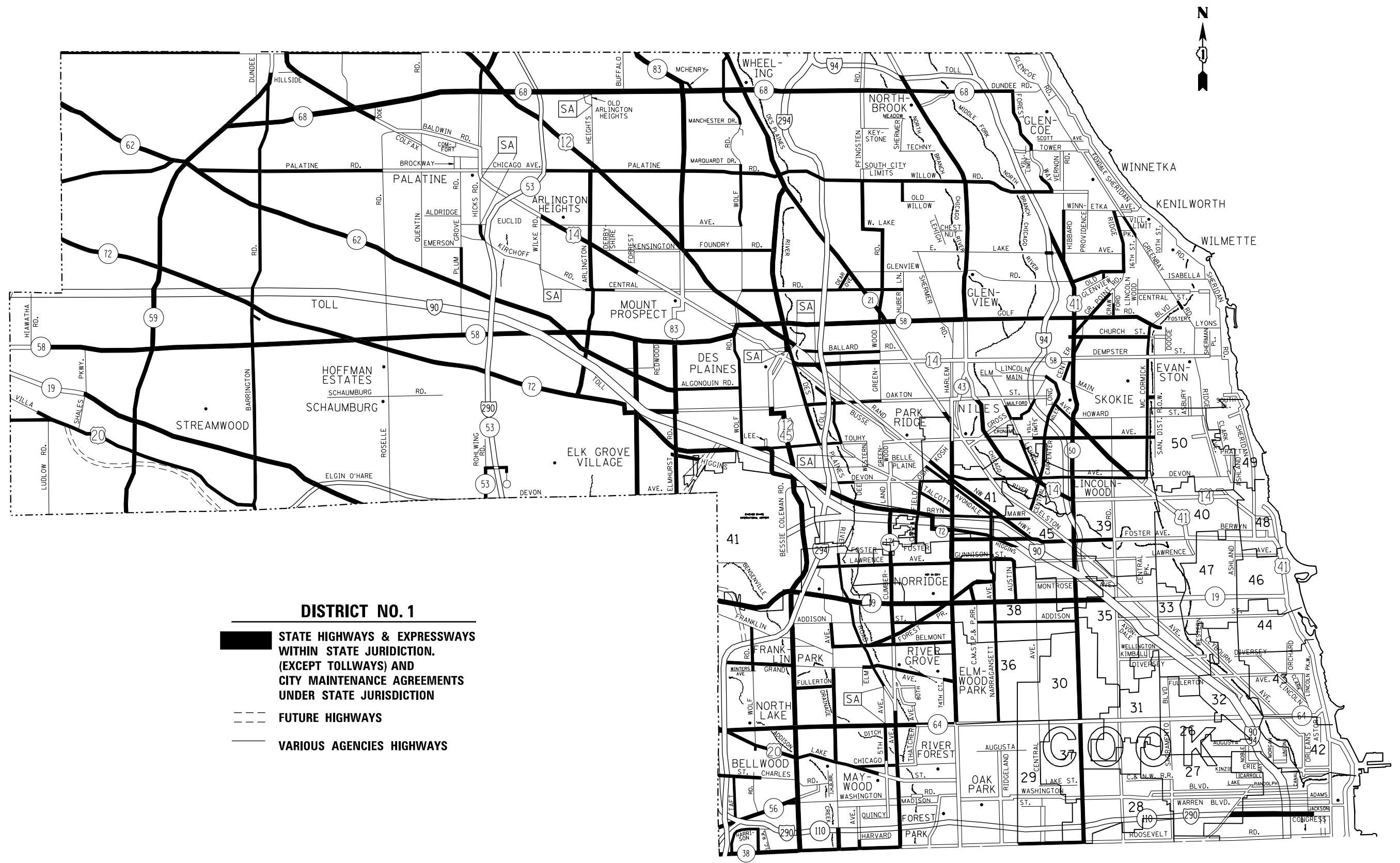

**DISTRICT NO. 1**

- STATE HIGHWAYS & EXPRESSWAYS  
WITHIN STATE JURISDICTION.  
(EXCEPT TOLLWAYS) AND  
CITY MAINTENANCE AGREEMENTS  
UNDER STATE JURISDICTION**
- FUTURE HIGHWAYS**
- VARIOUS AGENCIES HIGHWAYS**

FILE NAME =	USER NAME = Rodrigo.Ledezma	DESIGNED -	REVISED -
p:\dot\pw\Bentley.com\PWIDOT\Documents\DOT Offices\District 1\Projects\126122\CADD\Drawings\126122-sht-plan.dgn		REVISED -	REVISED -
		CHECKED -	REVISED -
		DATE -	REVISED -

**STATE OF ILLINOIS  
DEPARTMENT OF TRANSPORTATION**

**GUARDRAIL REPAIR LOCATION MAP COOK COUNTY  
NORTH OF AND INCLUDING IL. RTE 38**

SCALE: SHEET NO. OF SHEETS STA. TO STA.

F.A. RTE.	SECTION	COUNTY	TOTAL SHEETS	SHEET NO.
VAR.	2022 GUARDRAIL 01	VARIOUS	32	9
			CONTRACT NO. 62T90	
FED. ROAD DIST. NO.	ILLINOIS FED. AID PROJECT			



- DISTRICT NO. 1**
- STATE HIGHWAYS & EXPRESSWAYS WITHIN STATE JURISDICTION, (EXCEPT TOLLWAYS) AND CITY MAINTENANCE AGREEMENTS UNDER STATE JURISDICTION
  - FUTURE HIGHWAYS
  - VARIOUS AGENCIES HIGHWAYS

FILE NAME =	USER NAME = Rodrigo.Ledezma	DESIGNED -	REVISED -
p:\dot-pw.bentley.com\PWIDOT\Documents\DOT Offices\District 1\Projects\126122\CAD\Drawings\126122-sht-plan.dgn		DRAWN -	REVISED -
		CHECKED -	REVISED -
		DATE -	REVISED -

**STATE OF ILLINOIS  
DEPARTMENT OF TRANSPORTATION**

**GUARDRAIL REPAIR LOCATION MAP COOK COUNTY  
SOUTH OF IL RTE 38**

F.A. RTE.	SECTION	COUNTY	TOTAL SHEETS	SHEET NO.
VAR.	2022 GUARDRAIL 01	VARIOUS	32	10
CONTRACT NO. 62T90				
FED. ROAD DIST. NO.	ILLINOIS	FED. AID PROJECT		

SCALE: SHEET NO. OF SHEETS STA. TO STA.



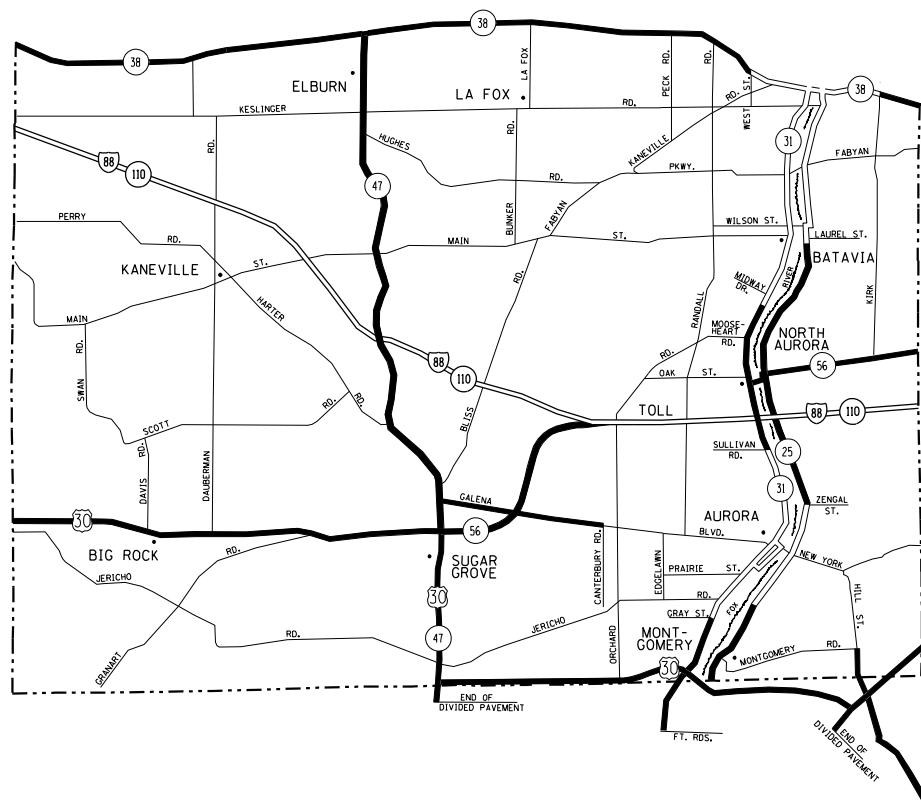

**DISTRICT NO. 1**

STATE HIGHWAYS & EXPRESSWAYS  
 WITHIN STATE JURISDICTION.  
 (EXCEPT TOLLWAYS) AND  
 CITY MAINTENANCE AGREEMENTS  
 UNDER STATE JURISDICTION

FUTURE HIGHWAYS

VARIOUS AGENCIES HIGHWAYS

FILE NAME =	USER NAME = Rodrigo.Ledezma	DESIGNED -	REVISED -
p:\11dot-pw.bentley.com\PWIDOT\Documents\11DOT Offices\District 1\Projects\0126122\CAD\DRAWING\0126122-sht-plan.dgn		CHECKED -	REVISED -
		DATE -	REVISED -

**STATE OF ILLINOIS  
DEPARTMENT OF TRANSPORTATION**

**GUARDRAIL REPAIR LOCATION MAP KANE COUNTY  
SOUTH OF IL RTE 38**

SCALE:      SHEET NO.      OF      SHEETS      STA.      TO      STA.

F.A. RTE.	SECTION	COUNTY	TOTAL SHEETS	SHEET NO.
VAR.	2022 GUARDRAIL 01	VARIOUS	32	11
CONTRACT NO. 62T90				
FED. ROAD DIST. NO.	ILLINOIS	FED. AID PROJECT		

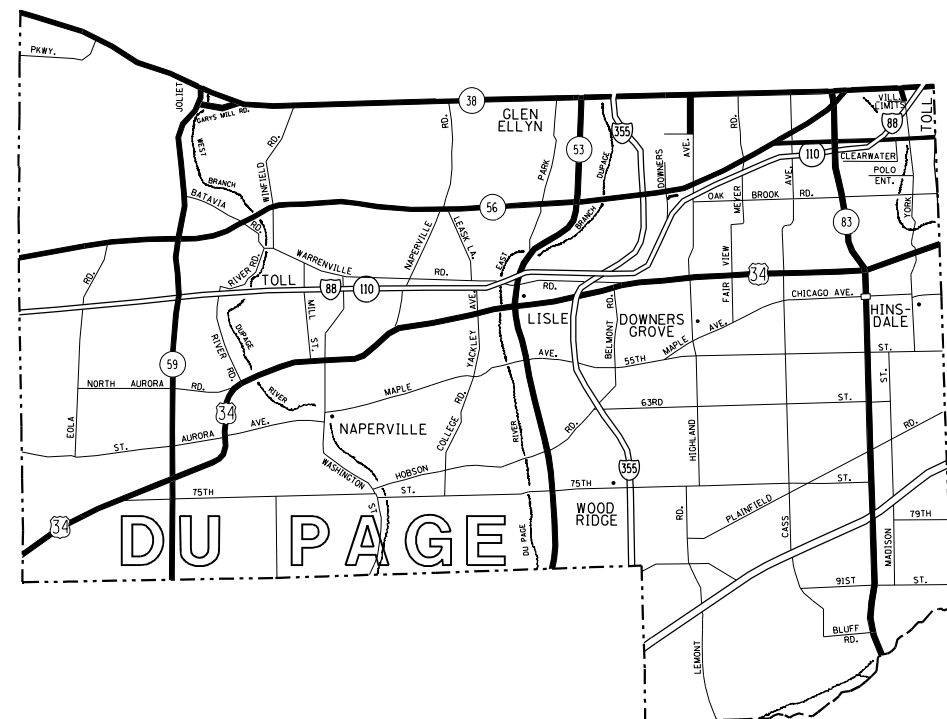

**DISTRICT NO. 1**

- STATE HIGHWAYS & EXPRESSWAYS WITHIN STATE JURISDICTION, (EXCEPT TOLLWAYS) AND CITY MAINTENANCE AGREEMENTS UNDER STATE JURISDICTION
- FUTURE HIGHWAYS
- VARIOUS AGENCIES HIGHWAYS

FILE NAME =	USER NAME = Rodrigo.Ledezma	DESIGNED -	REVISED -
pw:\idot-pw.bentley.com\PWIDOT\Documents\IDOT Offices\District 1\Projects\0126122\CAD\DRAWING\0126122-sht-plan.dgn		CHECKED -	REVISED -
		DATE -	REVISED -

**STATE OF ILLINOIS  
DEPARTMENT OF TRANSPORTATION**

**GUARDRAIL REPAIR LOCATION MAP DuPAGE COUNTY  
SOUTH OF IL RTE 38**

SCALE:      SHEET NO.    OF    SHEETS    STA.                    TO STA.

F.A. RTE.	SECTION	COUNTY	TOTAL SHEETS	SHEET NO.
VAR.	2022 GUARDRAIL 01	VARIOUS	32	12
			CONTRACT NO. 62T90	
FED. ROAD DIST. NO.	ILLINOIS FED. AID PROJECT			

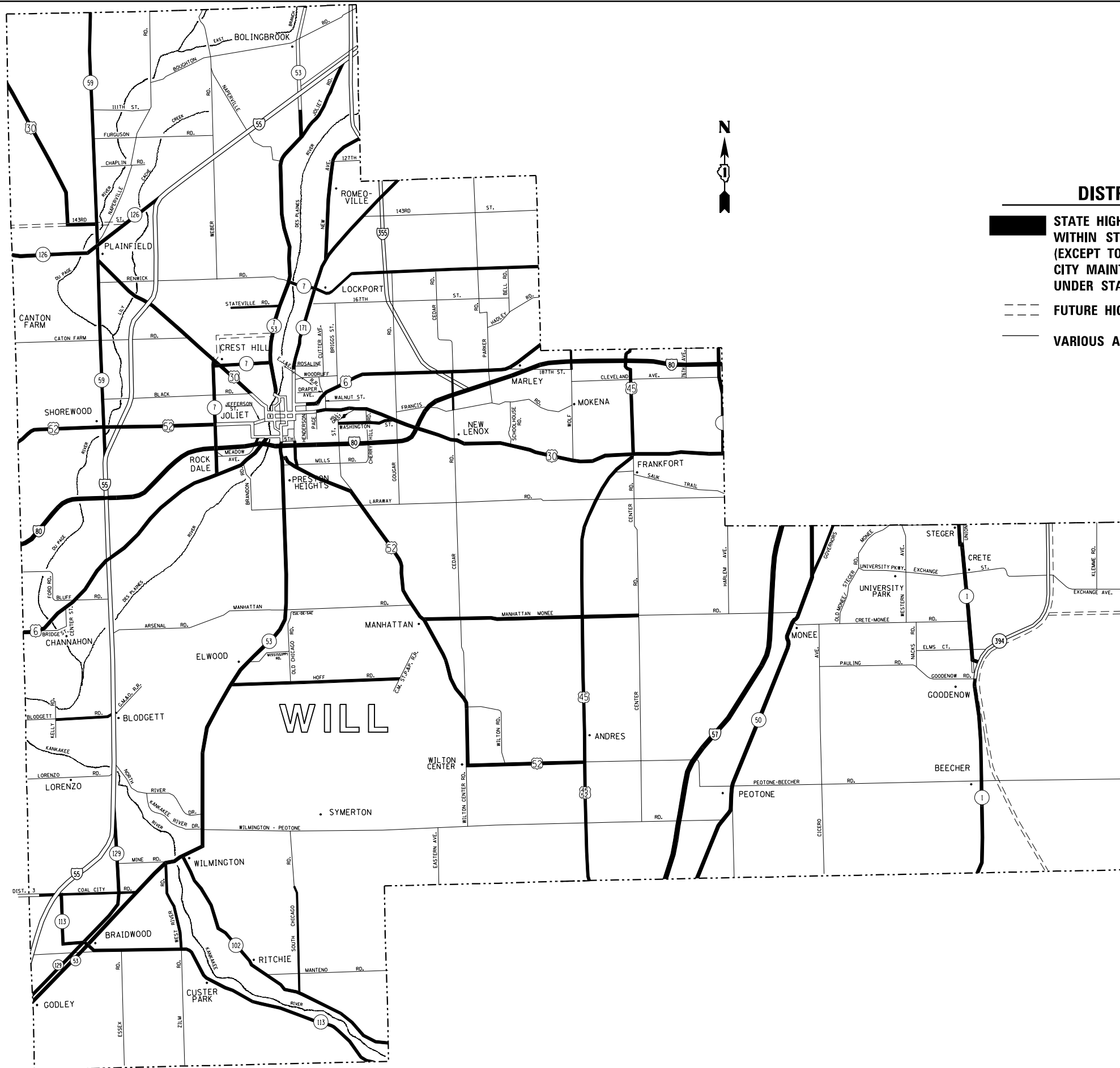

**DISTRICT NO. 1**

- STATE HIGHWAYS & EXPRESSWAYS WITHIN STATE JURISDICTION. (EXCEPT TOLLWAYS) AND CITY MAINTENANCE AGREEMENTS UNDER STATE JURISDICTION**
- FUTURE HIGHWAYS**
- VARIOUS AGENCIES HIGHWAYS**

FILE NAME =	USER NAME = Rodrigo.Ledezma	DESIGNED -	REVISED -
p:\1\dot-pw.bentley.com\PWIDOT\Documents\DOT Offices\District 1\Projects\0126122\CAD\Drawings\0126122-sht-plan.dgn		CHECKED -	REVISED -
		DATE -	REVISED -

**STATE OF ILLINOIS  
DEPARTMENT OF TRANSPORTATION**

**GUARDRAIL REPAIR LOCATION MAP  
WILL COUNTY**

SCALE:      SHEET NO.      OF      SHEETS      STA.      TO      STA.

F.A. RTE.	SECTION	COUNTY	TOTAL SHEETS	SHEET NO.
VAR.	2022 GUARDRAIL 01	VARIOUS	32	13
			CONTRACT NO. 62T90	
FED. ROAD DIST. NO.		ILLINOIS FED. AID PROJECT		



NOTE:

1. FOR DETAILS OF RAIL ELEMENTS, RAIL SPLICING, NUT, BOLT AND SIDE VIEW OF RAIL, SEE STANDARD 2230-2.
2. ALL WELDS SHALL BE GROUND SMOOTH
3. POSTS SHALL BE CUT AND WELDED TO THE BASE PLATE SO THAT THE POST WILL BE PLUMB WHEN ERECTED.
4. TWO PERCENT (2%) OF ALL ANCHOR BOLTS SHALL BE TEST LOADED IN PLACE, MINIMUM TEST LOAD=8 KIPS. IF ONE ANCHOR BOLT FAILS DURING THE TEST, TWO OTHER ANCHOR BOLTS SHALL BE TESTED. TESTING EQUIPMENT SHALL BE BOLT COMPANIES.
5. PROVIDE 11#8" AND 21#16" GALVANIZED SHIMS FOR 25% OF THE POSTS.

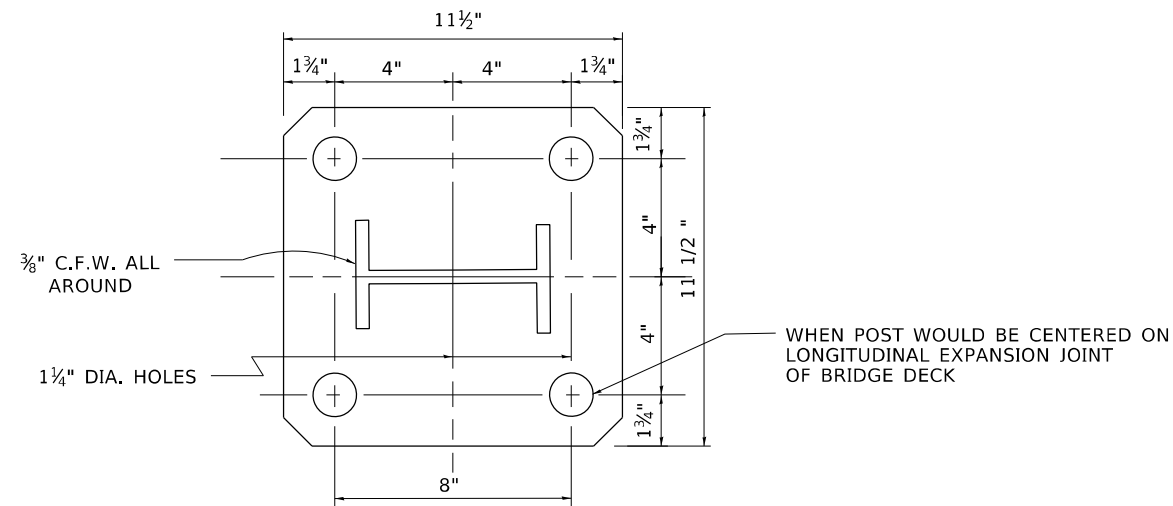

RAIL POST BASE  $\square$   
 $\square$  11 1/2" x 1 1/4" x 11 1/2"

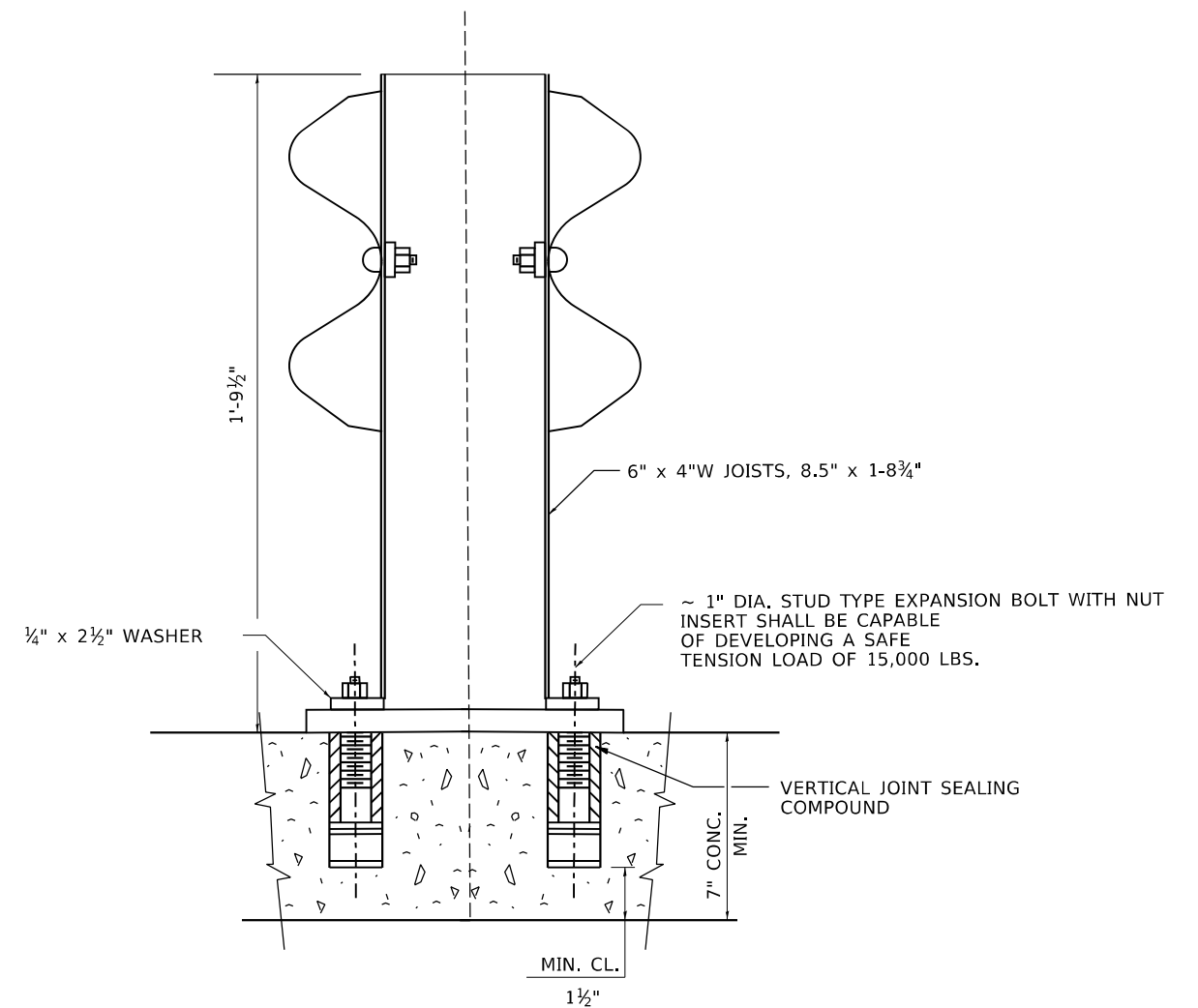

MODEL: Default  
 FILE: Mainfile.pdw  
 PROJECT: C:\Users\rodri\Documents\DOT Office\Bridges\11\Project\1126122\CADD\Drawings\Bridges\1126122.dwg  
 USER: Rodrigo.Ledezma  
 DATE: 7/7/2022

USER NAME = Rodrigo.Ledezma	DESIGNED -	REVISED - R. RITCHIE 05-02-00
	DRAWN - RFL	REVISED -
PLOT SCALE = 100,0000' / in.	CHECKED -	REVISED -
PLOT DATE = 7/7/2022	DATE - 10-31-88	REVISED -

STATE OF ILLINOIS  
 DEPARTMENT OF TRANSPORTATION

ANCHOR DETAIL FOR STEEL PLATE BEAM  
 GUARDRAIL ON CONCRETE

SCALE: NONE SHEET 1 OF 1 SHEETS STA. TO STA.

F.A. RTE.	SECTION	COUNTY	TOTAL SHEETS	SHEET NO.
VAR	2022 GUARDRAIL 01	VARIOUS	32	14
BM-02		CONTRACT NO. 62T90		
ILLINOIS FED. AID PROJECT				

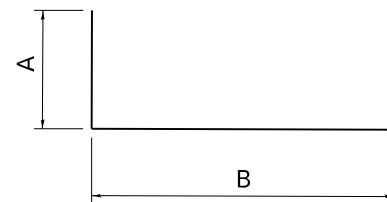
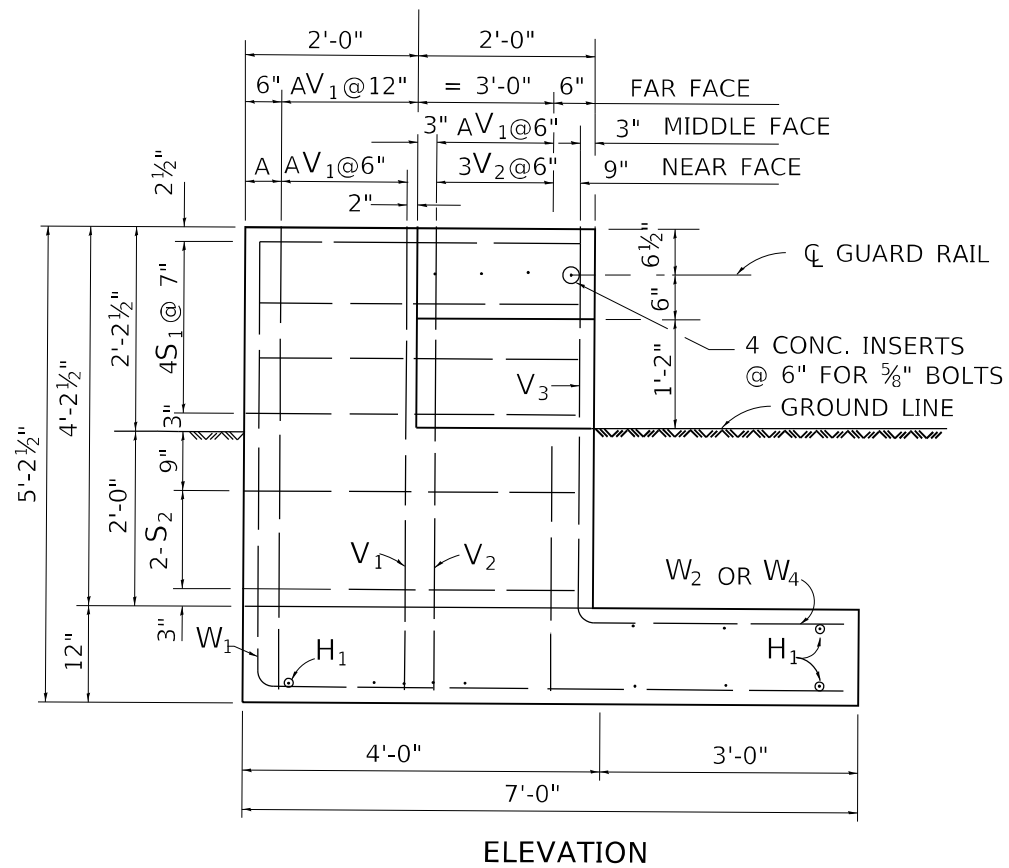

BAR	A	B	A+B
V <sub>1</sub>	4'-8"	6"	5'-2"
V <sub>2</sub>	2'-6"	6"	3'-0"
W <sub>1</sub>	4'-8"	6'-6"	11'-2"
W <sub>2</sub>	2'-0"	3'-0"	5'-0"
W <sub>4</sub>	4'-2"	3'-0"	7'-2"

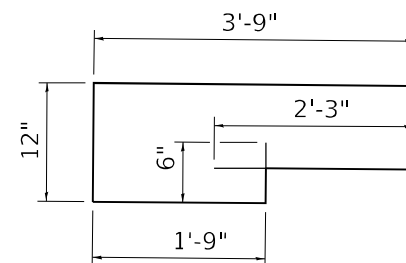

**S<sub>1</sub> BAR**

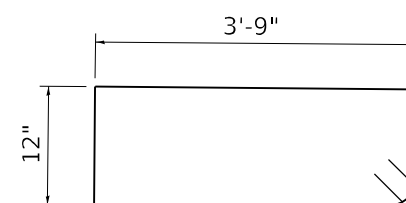

**S<sub>2</sub> BAR**

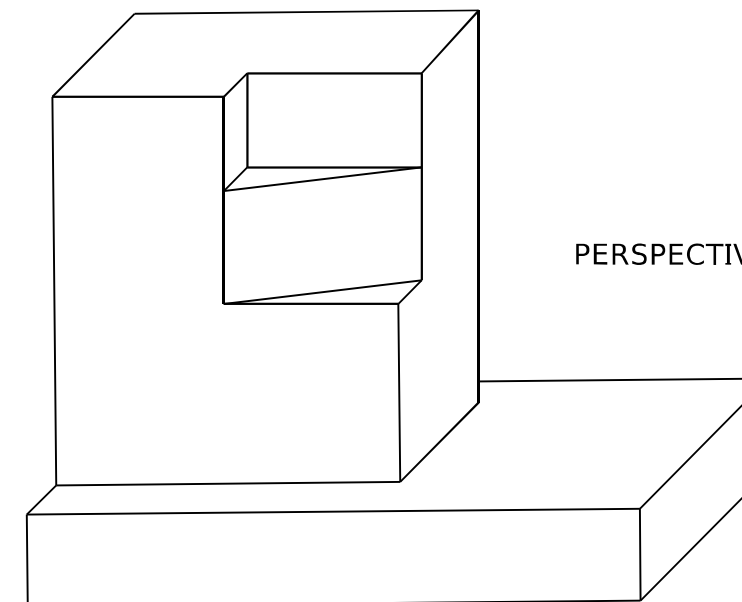

**PERSPECTIVE VIEW**

**NOTES:**

CLASS X CONCRETE SHALL BE USED THROUGHOUT  
REINFORCEMENT TO BE SIZE #4 UNLESS OTHERWISE NOTED

**ELEVATION**

**BAR SCHEDULE**

BAR	NO.	LENGTH
V <sub>1</sub>	8	5'-2"
V <sub>2</sub>	3	3'-0"
V <sub>3</sub>	4	3'-0"
W <sub>1</sub>	3	11'-2"
W <sub>2</sub>	1	5'-0"
W <sub>3</sub>	2	6'-6"
W <sub>4</sub>	2	7'-2"
S <sub>1</sub>	4	10'-0"
S <sub>2</sub>	2	10'-0"
H <sub>1</sub>	1	2'-3"

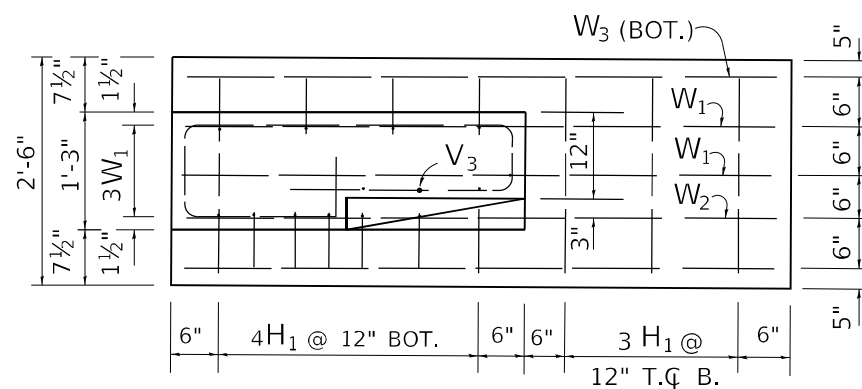

**FOOTING PLAN**

**THIS SHEET IS FOR INFORMATION ONLY**

MODEL: Default  
 FILE: \\blmfe-pw-bentley.com\P\W\DOT\Documents\DOT Office\Dir\rdt - I\Project\1216122\CADD\data\Design\BMS.dgn

USER NAME = Rodrigo.Ledezma	DESIGNED -	REVISED - R. RITCHIE 06-02-00
PLOT SCALE = 100,0000' / in.	DRAWN - R.F.L.	REVISED -
PLOT DATE = 7/7/2022	CHECKED -	REVISED -
	DATE - 10-31-88	REVISED -

**STATE OF ILLINOIS  
DEPARTMENT OF TRANSPORTATION**

<b>TYPICAL DETAIL FOR GUARDRAIL ANCHOR BLOCK REPAIR</b>			
SCALE: NONE	SHEET 1	OF 1 SHEETS	STA. TO STA.

F.A. RTE.	SECTION	COUNTY	TOTAL SHEETS	SHEET NO.
VAR	2022 GUARDRAIL 01	VARIOUS	32	15
<b>BM-03</b>			CONTRACT NO. 62T90	
ILLINOIS FED. AID PROJECT				

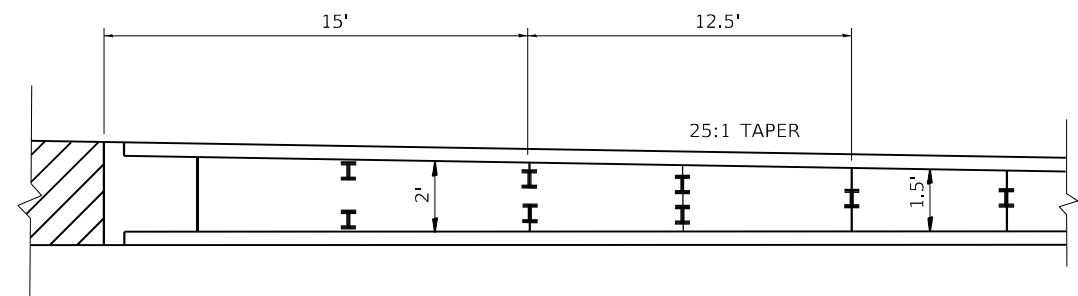
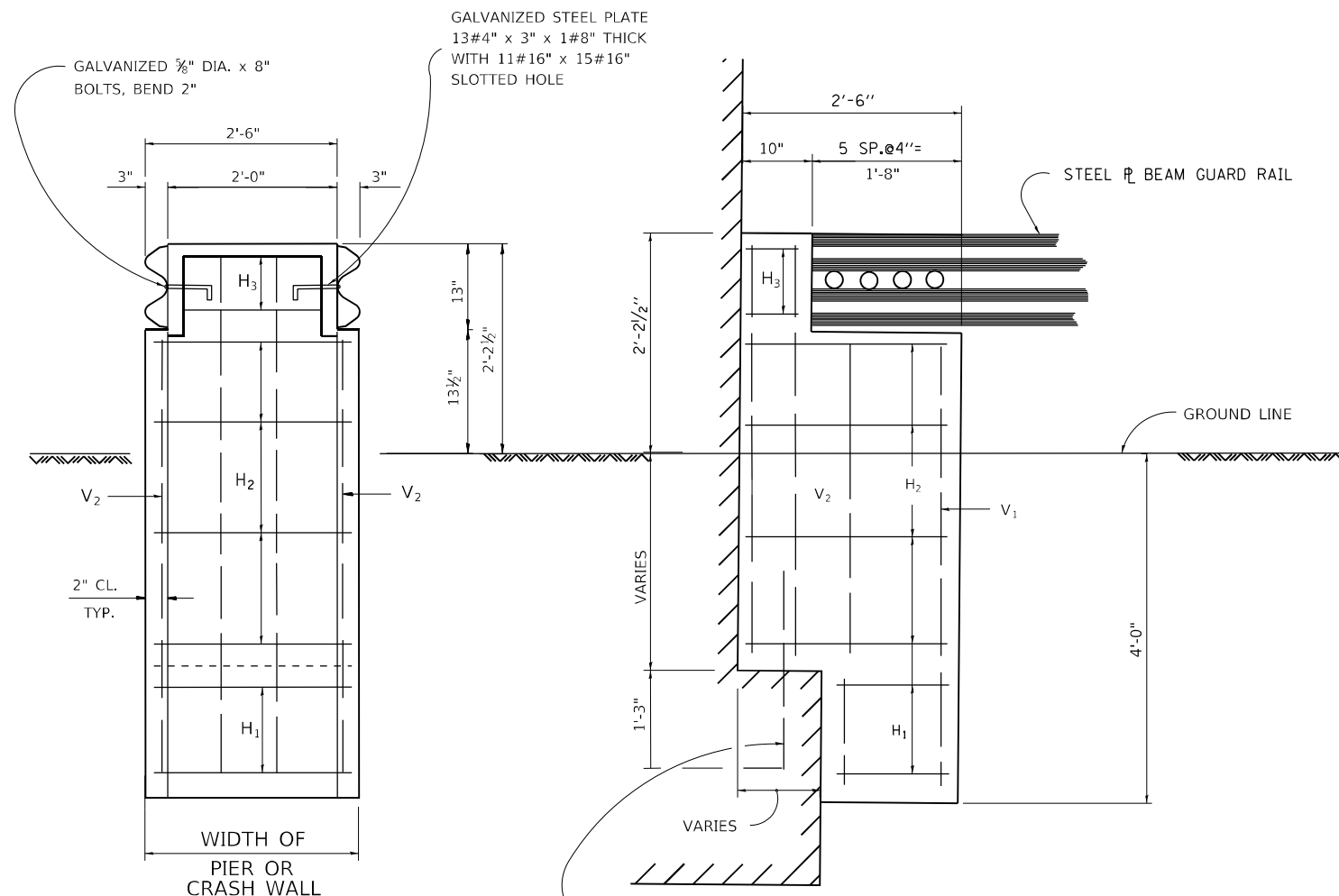

**GUARD RAIL TRANSITIONS**

NOTES: CLASS X CONCRETE SHALL BE USED THROUGHOUT  
REINFORCEMENT TO BE SIZE #4 UNLESS OTHERWISE NOTED

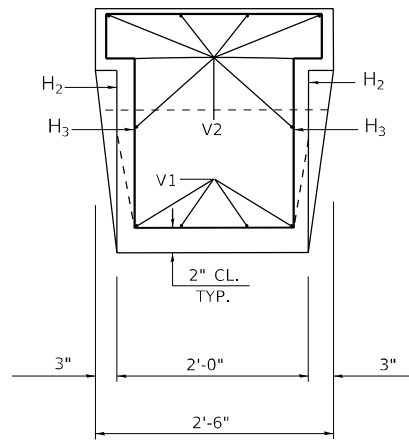

#6 DOWEL BARS  
DRILL AND GROUT ON ROW OF THREE BARS

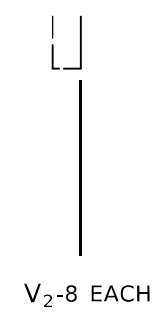
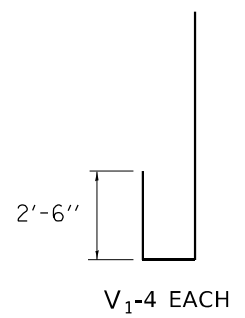
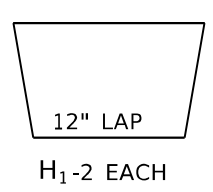
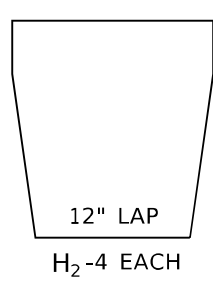
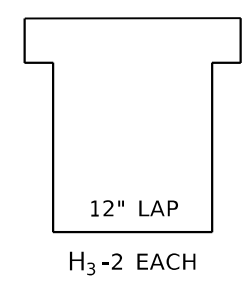

MODEL: Default  
FILE NAME: p:\project\paw\_bentley.com\P\INDOT\Documents\DOT Office\Dir\rdet\_1\Project\12161221\CADD\Drawings\Design\BRTStc.dgn

USER NAME = Rodrigo.Ledezma	DESIGNED -	REVISED - R. RITCHIE 05-02-00
PLOT SCALE = 100,0000' / in.	DRAWN - R.F.L.	REVISED -
PLOT DATE = 7/7/2022	CHECKED -	REVISED -
	DATE - 10-31-88	REVISED -

**STATE OF ILLINOIS  
DEPARTMENT OF TRANSPORTATION**

**TYPICAL DETAILS FOR STEEL PLATE BEAM GUARDRAIL ANCHORAGE REPAIR**

SCALE: NONE SHEET 1 OF 1 SHEETS STA. TO STA.

F.A. RTE.	SECTION	COUNTY	TOTAL SHEETS	SHEET NO.
VAR	2022 GUARDRAIL 01	VARIOUS	32	16
<b>BM-04</b>			CONTRACT NO. 62T90	
ILLINOIS FED. AID PROJECT				



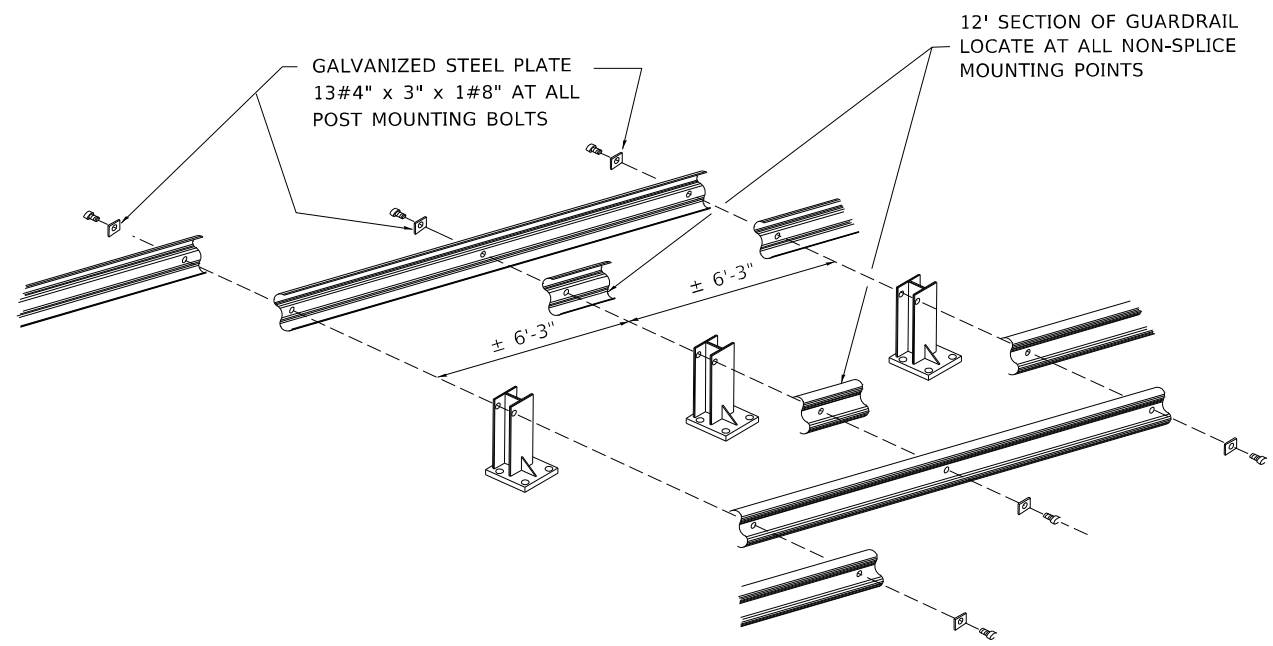
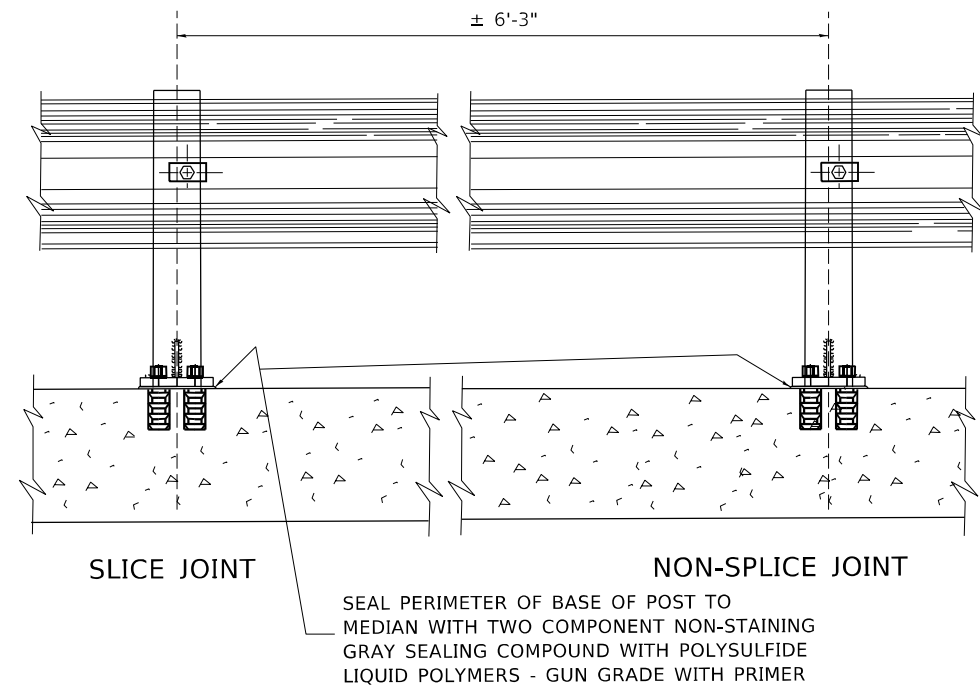
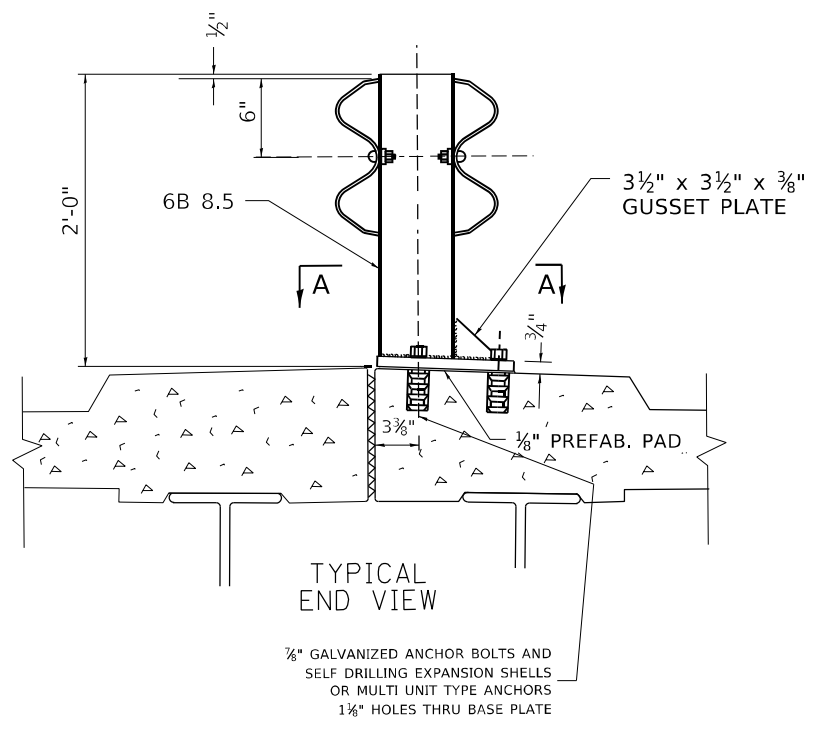

NOTE:  
DIAMOND TIPPED DRILL SHALL BE USED TO DRILL THRU REINFORCEMENT BARS

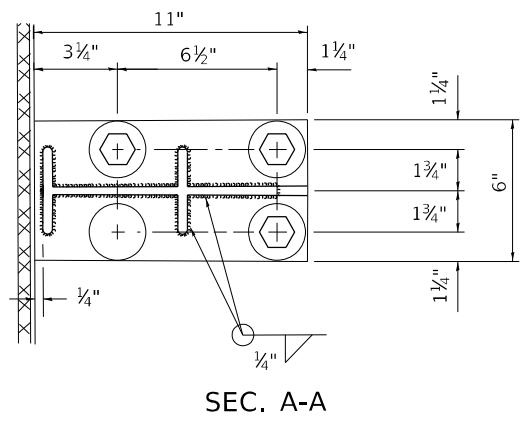

- NOTE:
1. POSTS SHALL BE HOT DIPPED GALVANIZED AFTER FABRICATION IN ACCORDANCE WITH ASTM DESIGNATIONS A-123 AND A-385.
  2. TWO PERCENT (2%) OF ALL ANCHOR BOLTS SHALL BE TEST LOADED IN PLACE. MIN. TEST LOAD = 8 KIPS.
  3. ALL BOLTS, NUTS AND WASHERS SHALL BE GALVANIZED IN ACCORDANCE WITH ASTM DESIGNATION A-153.
  4. FOR MATERIAL COMPOSITION OF PREFABRICATED PAD, SEE ARTICLE 54.9(F), (BEARING AND ANCHORAGE), OF THE STANDARD SPECIFICATIONS.
  5. PROVIDE 1-1#8" AND 2-1#16" GALVANIZED STEEL SHIMS FOR 25% OF THE POSTS.
  6. IF ONE ANCHOR BOLT FAILS DURING TEST, TWO OTHER ANCHOR BOLTS SHALL BE TESTED. TESTING EQUIPMENT CAN BE OBTAINED FROM BOLT COMPANIES.

THIS SHEET IS FOR INFORMATION ONLY

MODEL: Default FILE NAME: p:\project\paw\benefit\com\paw\dot\Documents\DOT Office\Drawings\11\project\1126122\CADD\data\Design\BMS\Std.dgn

USER NAME = Rodrigo.Ledezma	DESIGNED -	REVISED - R. RITCHIE 05-02-00
PLOT SCALE = 100,0000' / in.	DRAWN - R.F.L.	REVISED -
PLOT DATE = 7/7/2022	CHECKED -	REVISED -
	DATE - 10-31-88	REVISED -

STATE OF ILLINOIS  
DEPARTMENT OF TRANSPORTATION

TYPICAL DETAIL FOR CENTER LONGITUDINAL JOINT GUARDRAIL JOINT			
SCALE: NONE	SHEET 1	OF 1 SHEETS	STA. TO STA.

F.A. RTE.	SECTION	COUNTY	TOTAL SHEETS	SHEET NO.
VAR	2022 GUARDRAIL 01	VARIOUS	32	17
BM-05			CONTRACT NO. 62T90	
ILLINOIS FED. AID PROJECT				

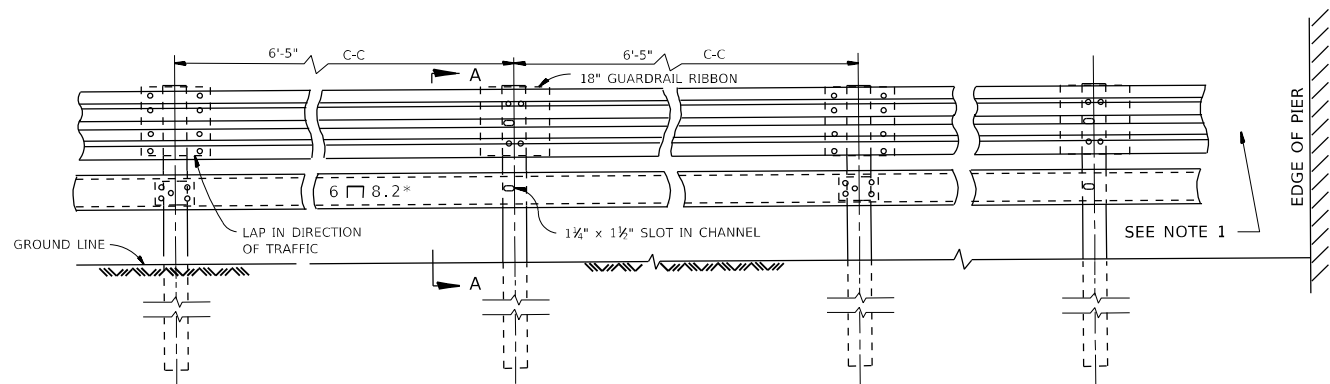

ELEVATION

DETAIL OF END SECTION

NOTE 1:  
FOR DETAILS OF GUARDRAIL END ANCHORAGE AT PIERS, SEE SHEET NO. \_\_\_\_

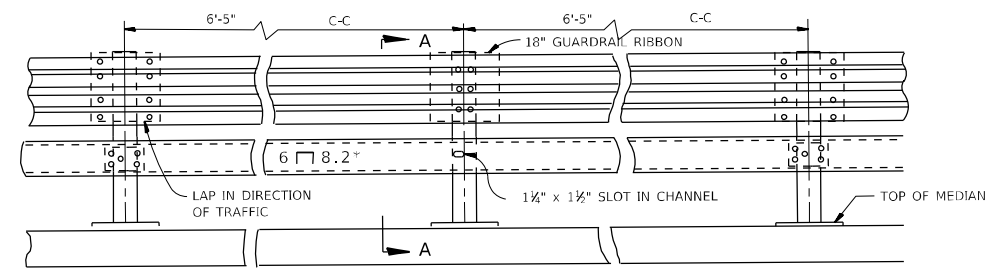

ELEVATION

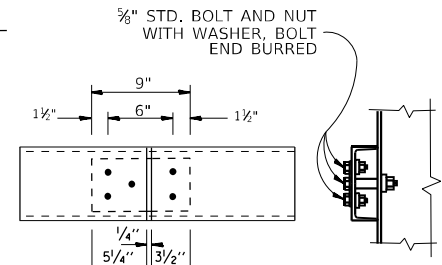

CHANNEL SPLICE  
PLATE 8 3/4" x 4 1/2" x 1/4"

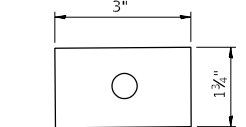

WASHER  
PLATE 3" x 1 3/4" x 1/8"

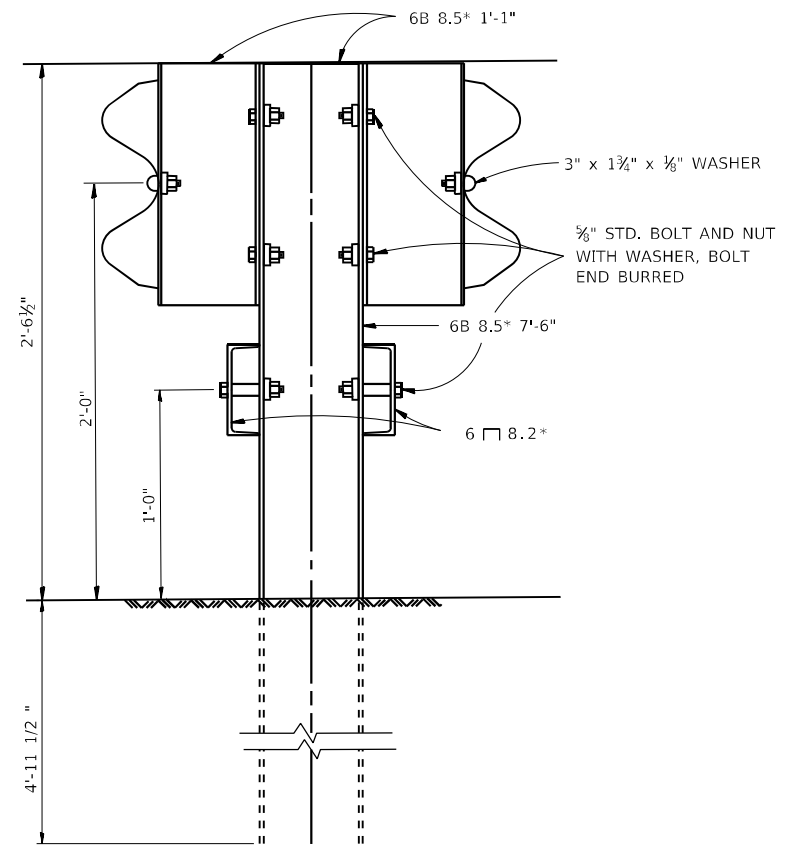

SECTION A-A

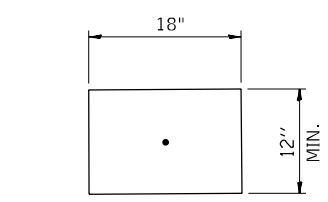

18" GUARDRAIL ELEMENT SPLICE

NOTE:  
FOR DETAIL OF RAIL ELEMENT, RAIL SPLICING, BOLT, AND NUT, SEE STATE STANDARD 2230.  
A 13#8" x 3" x 1#8" STEEL PLATE WASHER AS SHOWN ON THIS DRAWING SHALL BE PLACED BETWEEN THE BOLT HEAD AND THE GUARDRAIL RIBBON AT ALL MOUNTING POINTS. AN 18" PIECE OF GUARDRAIL RIBBON SHALL BE INSERTED BETWEEN THE CONTINUOUS RIBBON AND THE POST AT NON-SLICE MOUNTING POINTS.  
RAIL, CHANNELS, POSTS, BASE PLATES, FASTENINGS, AND ALL OTHER EXPOSED ACCESSORIES SHALL BE GALVANIZED.

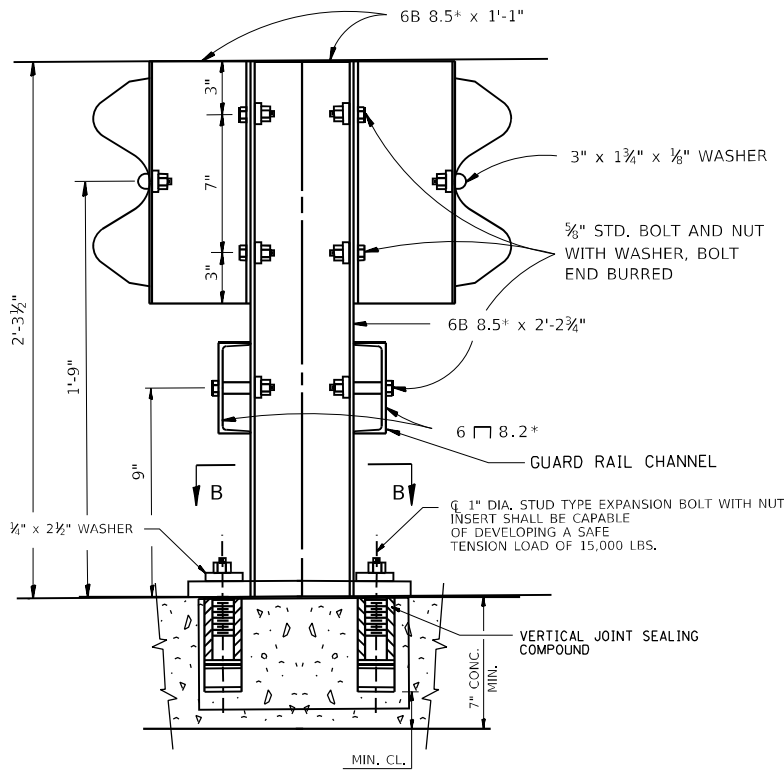

SECTION A-A  
ANCHORAGE DETAIL

NOTE:  
ALL WELDS SHALL BE GROUND SMOOTH. POSTS SHALL BE CUT AND WELDED TO THE BASE PLATE SO THAT THE POSTS WILL BE PLUMB WHEN ERECTED.

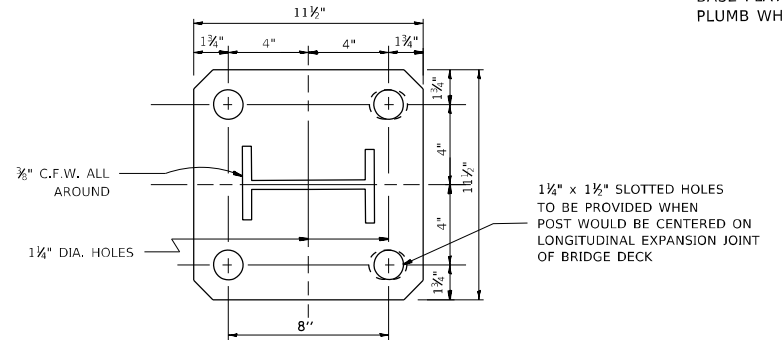

RAIL POST BASE PLATE  
LP 11 1/2" x 1 1/2" x 11 1/2"

SECTION B-B

THIS SHEET IS FOR INFORMATION ONLY

MODEL: Default  
FILE NAME: p:\bulletect-pw-bead\paw.com\PIV\DOT\Documents\DOT Office\Dir\rdet\_11\Project\121212\CADD\data\Design\BRTStd.dgn

USER NAME = Rodrigo.Ledezma	DESIGNED -	REVISED - R. RITCHIE 05-02-00
PLOT SCALE = 100,0000' / in.	DRAWN - R.F.L.	REVISED -
PLOT DATE = 7/7/2022	CHECKED -	REVISED -
	DATE -	REVISED -

STATE OF ILLINOIS  
DEPARTMENT OF TRANSPORTATION

STEEL PLATE BEAM GUARDRAIL  
SPECIAL

SCALE: NONE SHEET 1 OF 1 SHEETS STA. TO STA.

F.A. RTE.	SECTION	COUNTY	TOTAL SHEETS	SHEET NO.
VAR	2022 GUARDRAIL 01	VARIOUS	32	18
	BM-06		CONTRACT NO. 62790	
		ILLINOIS	FED. AID PROJECT	

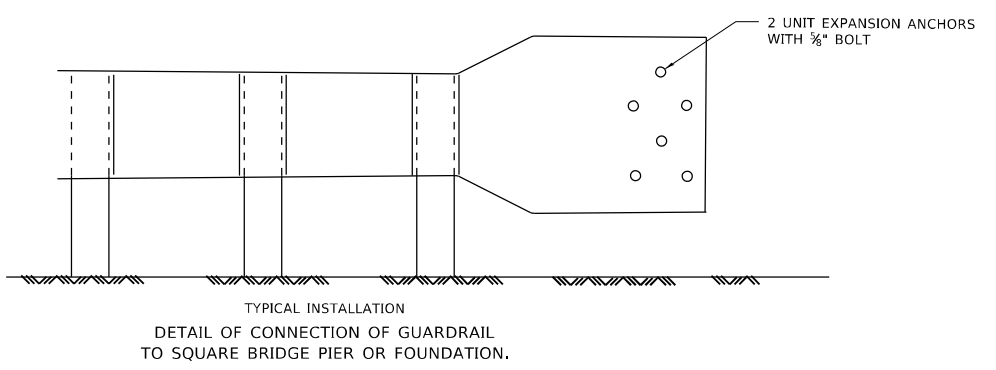
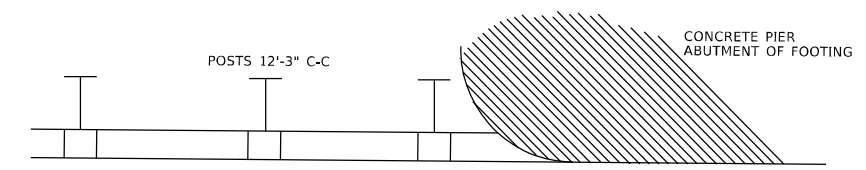
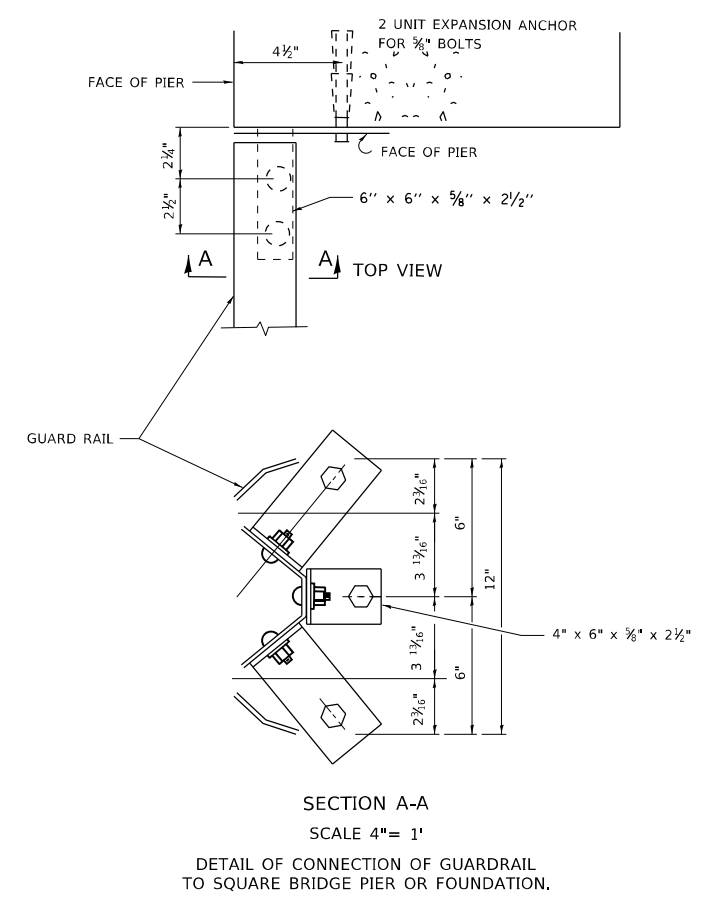
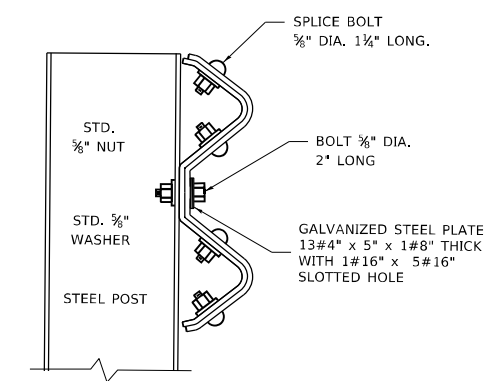
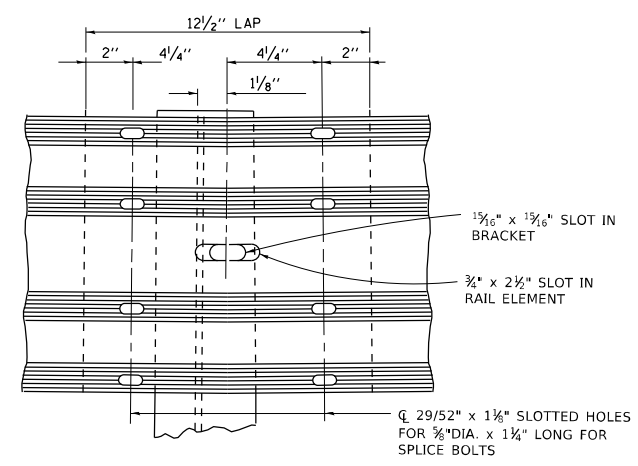
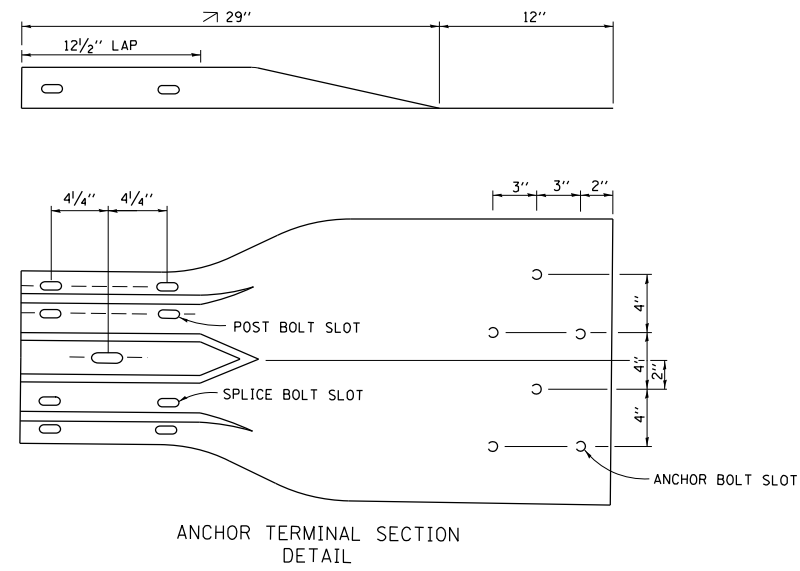

THIS SHEET IS FOR INFORMATION ONLY

MODEL: Default  
 FILE: \\nafe-pw-bentley.com\P\DOT\Documents\DOT Office\Dir\drt. I\Project\126122\CADD\Drawings\Bentley.dgn

USER NAME = Rodrigo.Ledezma	DESIGNED -	REVISED - R. RITCHIE 05-02-00
	DRAWN - R.F.L.	REVISED -
PLOT SCALE = 100,0000 ' / in.	CHECKED -	REVISED -
PLOT DATE = 7/7/2022	DATE - 10-31-88	REVISED -

STATE OF ILLINOIS  
DEPARTMENT OF TRANSPORTATION

DETAIL OF GUARDRAIL SUPPORT AND END ANCHORAGE			
SCALE: NONE	SHEET 1	OF 1 SHEETS	STA. TO STA.

F.A. RTE.	SECTION	COUNTY	TOTAL SHEETS	SHEET NO.
VAR	2022 GUARDRAIL 01	VARIOUS	32	19
BM-07		CONTRACT NO. 62T90		
ILLINOIS FED. AID PROJECT				

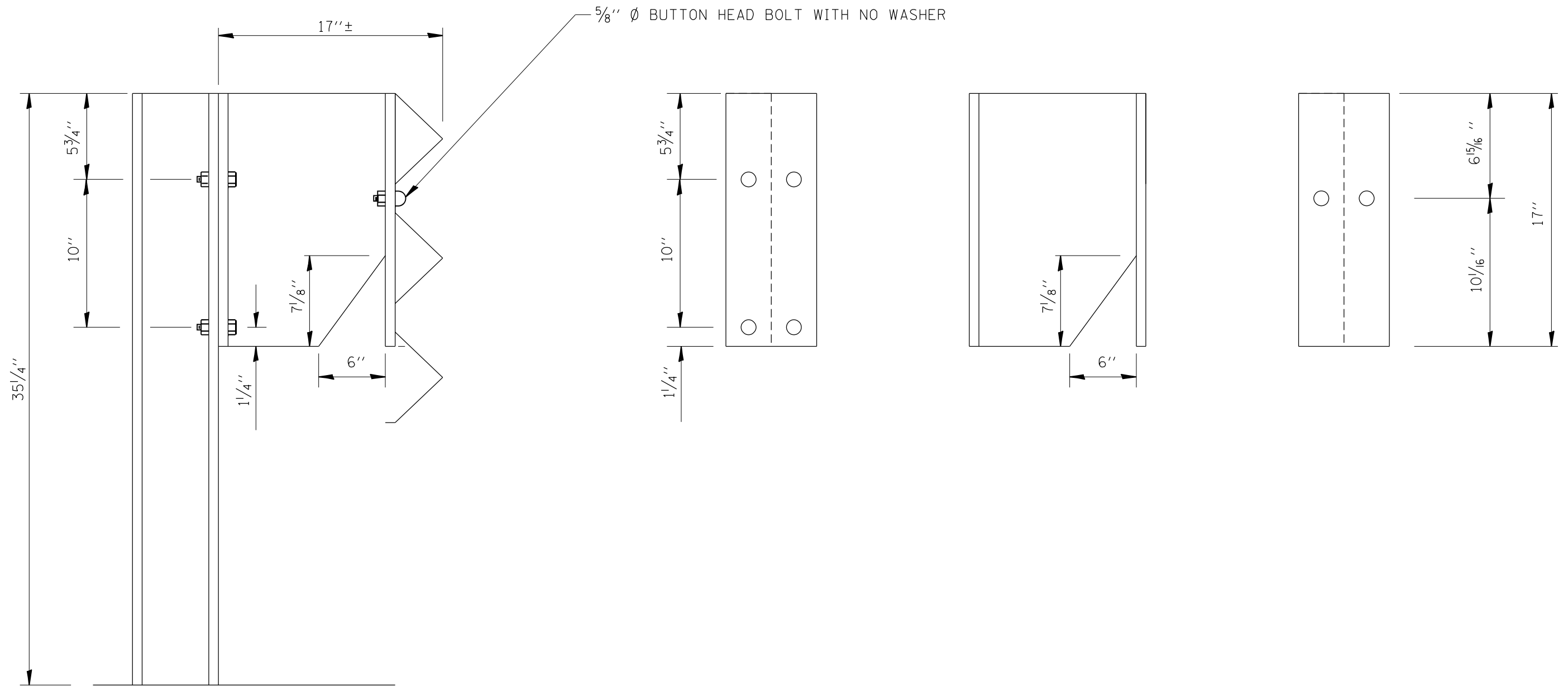

FILE NAME =	USER NAME = Rodrigo.Ledezma	DESIGNED -	REVISED -
p:\1\dot-pw.bentley.com\PWIDOT\Documents\IDOT Offices\District 1\Projects\0126122\CAD\DRAWING\0126122-sht-plan.dgn		DRAWN	REVISED -
PLOT SCALE = 100.0000' / 1"	CHECKED -	REVISED -	REVISED -
PLOT DATE = 7/7/2022	DATE -	REVISED -	REVISED -

**STATE OF ILLINOIS  
DEPARTMENT OF TRANSPORTATION**

<b>DETAIL THREE BEAM GUARDRAIL WITH MODIFIED OFFSET BLOCK</b>			
SCALE:	SHEET NO.	OF SHEETS	STA. TO STA.

F.A. RTE.	SECTION	COUNTY	TOTAL SHEETS	SHEET NO.
VAR.	2022 GUARDRAIL 01	VARIOUS	32	20
FED. ROAD DIST. NO. ILLINOIS FED. AID PROJECT			CONTRACT NO. 62T90	

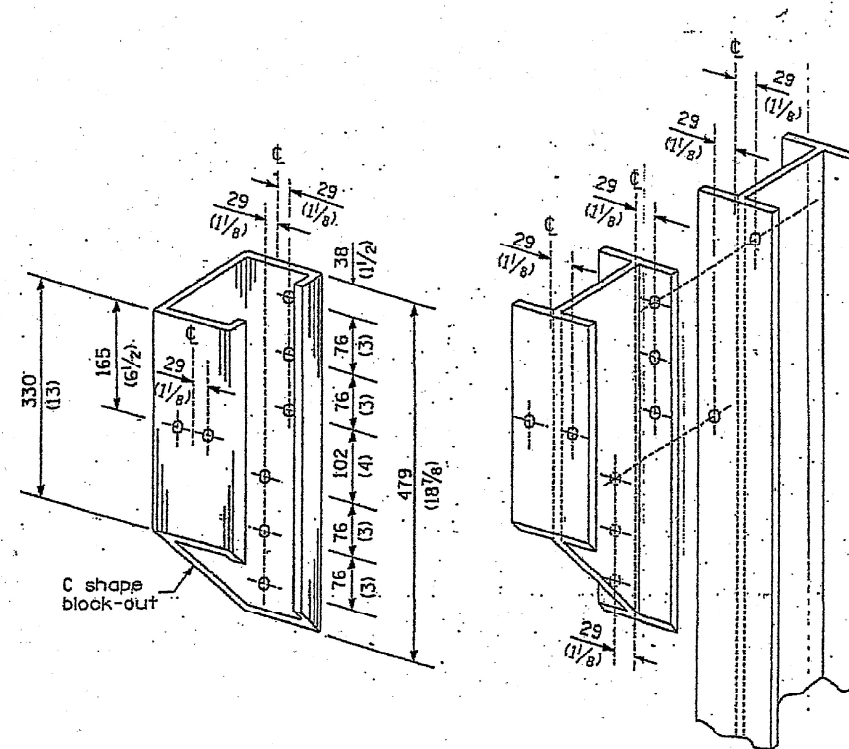

STEEL BLOCK-OUT AND  
STEEL POST DETAILS

FILE NAME =	USER NAME = Rodrigo.Ledezma	DESIGNED -	REVISED -
pw:\idot-pw.bentley.com\PWIDOT\Documents\IDOT Offices\District 1\Projects\0126122\CAD\DRAWING\0126122-sht-plan.dgn		DRAWN	REVISED -
Default	PLOT SCALE = 100.0000' / in.	CHECKED -	REVISED -
	PLOT DATE = 7/7/2022	DATE -	REVISED -

**STATE OF ILLINOIS**  
**DEPARTMENT OF TRANSPORTATION**

**STEEL PLATE BEAM GUARDRAIL**  
**STEEL BLOCK-OUT DETAIL**

SCALE: SHEET OF SHEETS STA. TO STA.

F.A. RTE.	SECTION	COUNTY	TOTAL SHEETS	SHEET NO.
VAR.	2022 GUARDRAIL 01	VARIOUS	32	21
			CONTRACT NO. 62T90	
ILLINOIS FED. AID PROJECT				

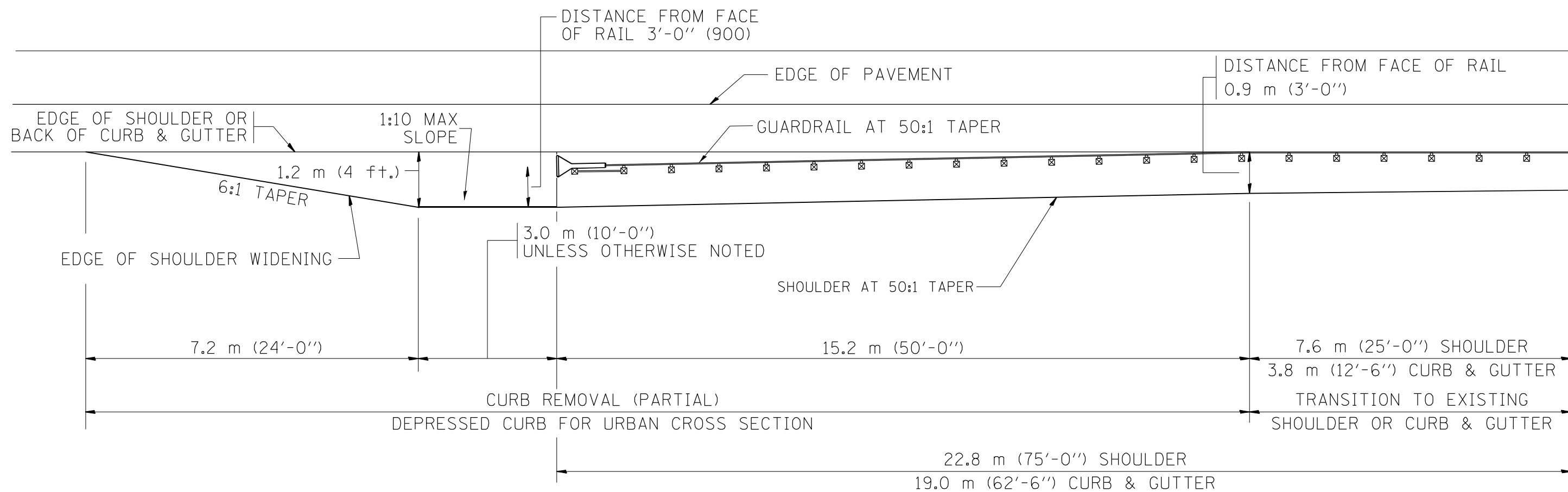

NOTES: THE CONTRACTOR SHALL VERIFY THE TYPE/HEIGHT OF GUARDRAIL IN-PLACE BEFORE ORDERING THE NEW TERMINAL SECTION. COST INCLUDED WITH THE COST OF THE TERMINAL. THE TERMINAL SECTION HEIGHT TO BE PLACED MUST MATCH THE HEIGHT OF THE IN-PLACE GUARDRAIL.

SHOULDER WIDENING SHALL BE IN ACCORDANCE WITH STATE STANDARD 630301

FILE NAME =	USER NAME = Rodrigo.Ledezma	DESIGNED -	REVISED -	<b>STATE OF ILLINOIS DEPARTMENT OF TRANSPORTATION</b>	<b>CURB REMOVAL (PARTIAL) FOR TRAFFIC BARRIER TERMINAL, TYPE 1 SPECIAL</b>	F.A. RTE.	SECTION	COUNTY	TOTAL SHEETS	SHEET NO.	
pw:\idot-pw.bentley.com\PWIDOT\Documents\IDOT Offices\District 1\Projects\0126122\CAD\DRAWING\0126122-sht-plan.dgn	DRAWN	REVISED -	REVISED -			VAR.	2022 GUARDRAIL 01	VARIOUS	32	22	
Default	PLOT SCALE = 100.0000' / in.	CHECKED -	REVISED -			CONTRACT NO. 62T90					
	PLOT DATE = 7/7/2022	DATE -	REVISED -			SCALE:	SHEET	OF	SHEETS	STA.	TO

\* Cut bottom end of post to curb slope.

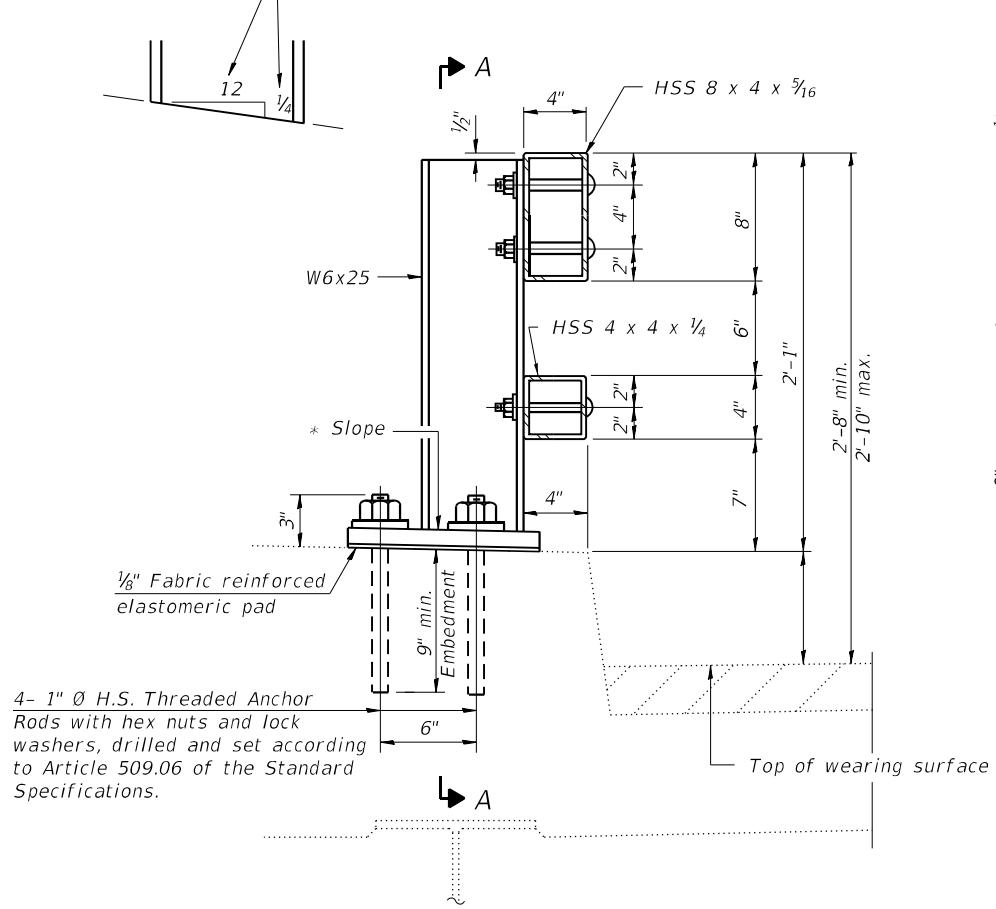

SECTION AT RAIL POST

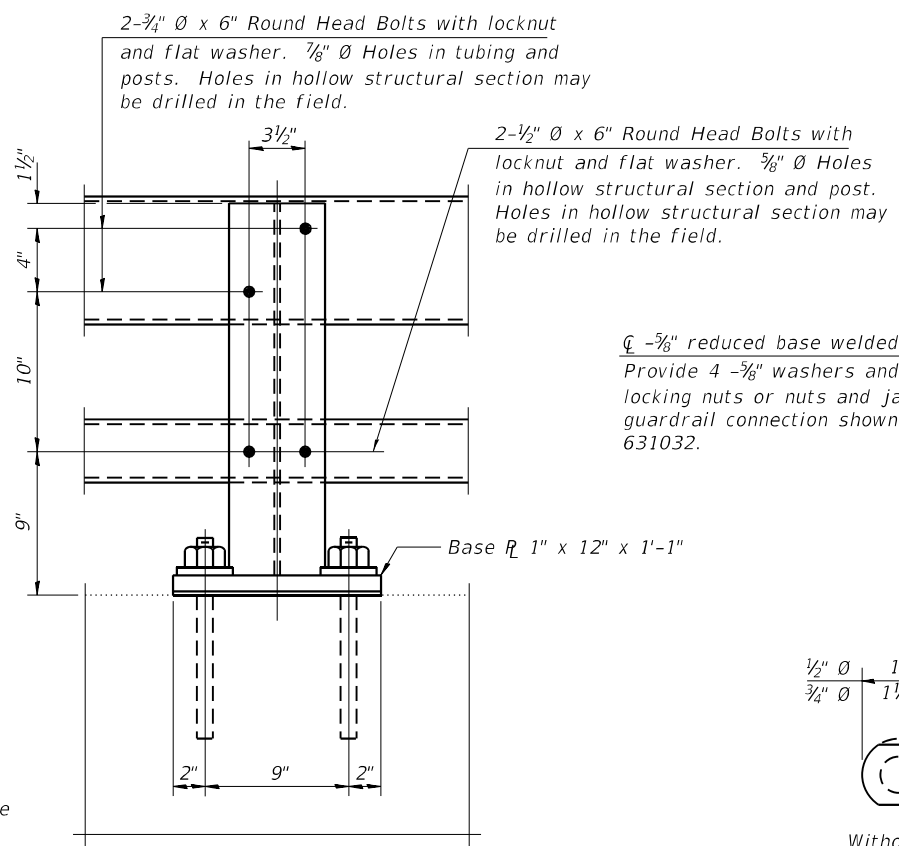

SECTION A-A

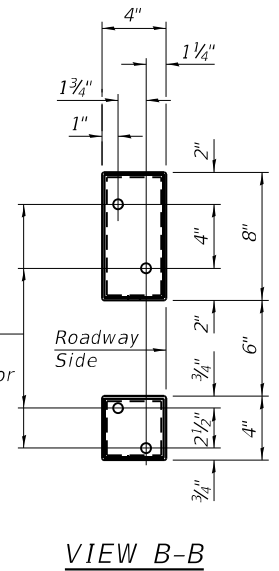

VIEW B-B

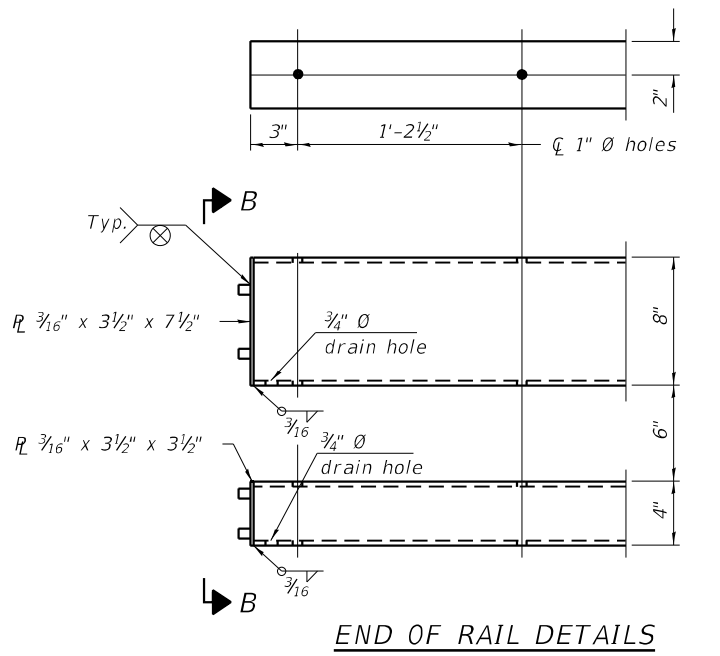

END OF RAIL DETAILS

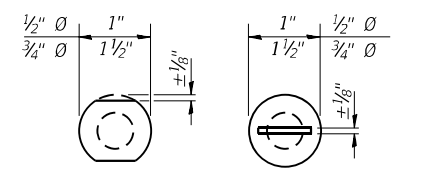

VIEW C-C

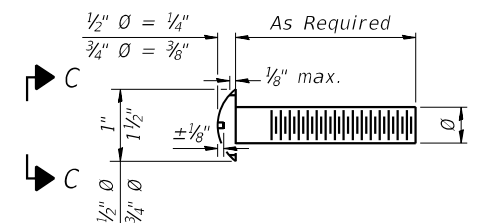

DETAIL OF 1/2" Ø & 3/4" Ø ROUND HEAD BOLTS

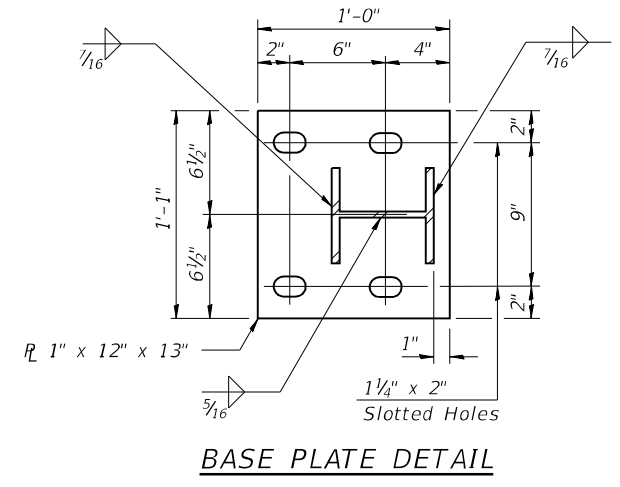

BASE PLATE DETAIL

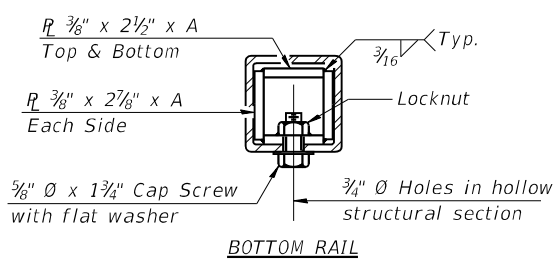

BOTTOM RAIL

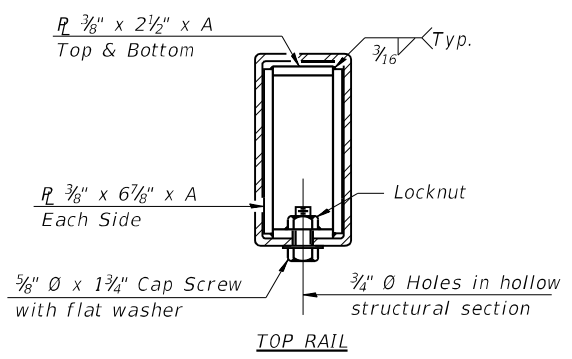

TOP RAIL

SECTIONS AT RAIL SPLICE

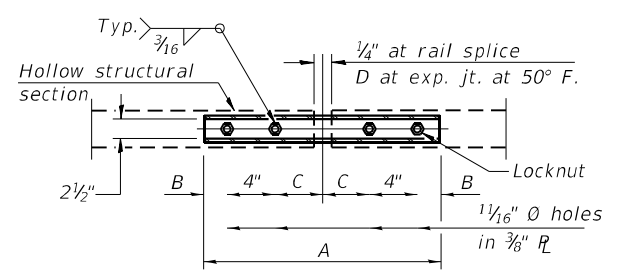

PLAN-BOTT. SPLICE R TYPICAL

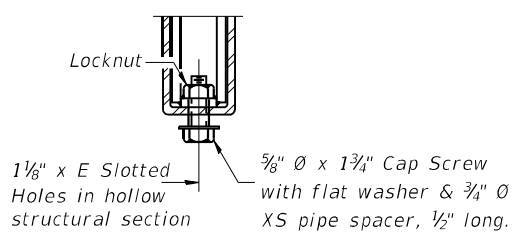

RAIL SPLICE CONNECTION AT EXPANSION JT.

Notes:  
 Posts shall not be located closer than 1'-3" to an existing bridge expansion joint or end of bridge.  
 Steel Bridge Rail expansion joint shall be provided between any two (2) posts which span a bridge expansion joint. Bolts located at expansion joint shall be provided with locknuts and shall be tightened only to a point that will allow railing movement.  
 Provide one 1/8" and two 1/16" steel shims for 25% of the posts. Shims shall be similar to base plates in size and holes.  
 All steel rail elements shall be galvanized according to Article 509.05 of the Standard Specifications.

SPLICE DIMENSIONS

T	D	A	B	C	E
≤ 4"	2 1/2"	1'-8"	2"	4"	2 1/2"
> 4" ≤ 6 1/2"	3 3/4"	2'-0"	2 1/2"	5 1/2"	3 1/2"
> 6 1/2" ≤ 9"	5"	2'-4"	3 1/2"	6 1/2"	9"
> 9" ≤ 13"	7"	2'-10"	4 1/2"	8 1/2"	11"
Rail Splice	1/4"	1'-8"	2"	4"	—

T = Total movement at expansion joint as shown on the design plans.

BILL OF MATERIAL

Item	Unit	Quantity
Steel Railing, Type 2399	Foot	



**PARAPET OR WINGWALL**

PAY LIMITS OF TRAFFIC BARRIER TERMINAL TYPE 6 (1 EACH)

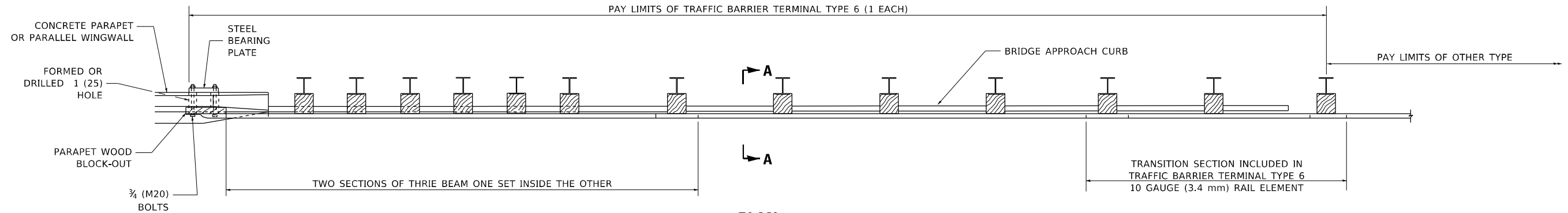

**PLAN**

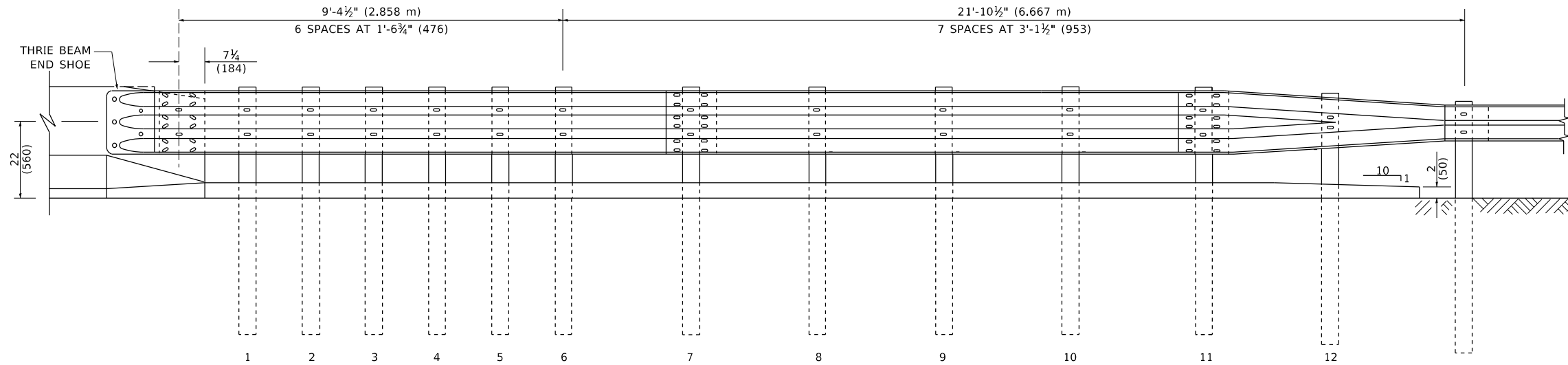

**ELEVATION**

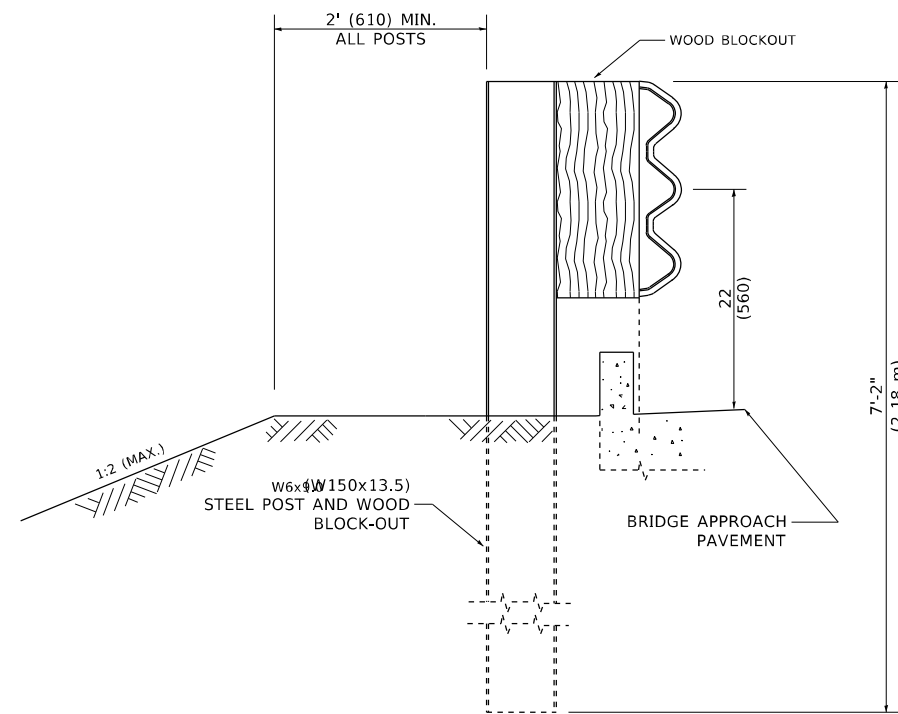

**SECTION A-A**

**GENERAL NOTES**

TO BE USED WHEN CONNECTING TO EXISTING GUARD RAILING PRIOR TO THE MIDWEST GUARDRAIL SYSTEM.

SEE STANDARD 630001 FOR DETAILS OF GUARDRAIL NOT SHOWN.

THRIE BEAM RAIL SHALL BE BOLTED TO BLOCK-OUT AT ALL POSTS.

SEE STANDARD 420401 FOR DETAILS OF BRIDGE APPROACH PAVEMENT.

ALL SLOPE RATIOS ARE EXPRESSED AS UNITS OF VERTICAL DISPLACEMENT TO UNITS OF HORIZONTAL DISPLACEMENT (V:H).

ALL DIMENSIONS ARE IN INCHES (MILLIMETERS) UNLESS OTHERWISE SHOWN.

ILLINOIS STATE STANDARD:  
631031-05 02/19/2008

STATE OF ILLINOIS  
DEPARTMENT OF TRANSPORTATION

**TYPE 6 TERMINAL**  
**FOR USE WITH 21" HIGH SPBGR**

USER NAME = Rodrigo, Ledezma	DESIGNED -	REVISED -
PLOT SCALE = 100,0000' / in.	DRAWN -	REVISED - 631031-05 02/19/2008
PLOT DATE = 7/7/2022	CHECKED -	REVISED -
	DATE -	REVISED -

SCALE: NONE SHEET 1 OF 3 SHEETS STA. TO STA.

F.A. RTE.	SECTION	COUNTY	TOTAL SHEETS	SHEET NO.
VAR	2022 GUARDRAIL 01	VARIOUS	32	24
<b>BM 22</b>		CONTRACT NO. 62T90		
ILLINOIS FED. AID PROJECT				

MODEL: Default  
 FILE: \\blm\paw\bea\paw.com\PIV\DOT\Documents\DOT Office\Dir\trdt. \\Project\12126122\CADD\data\Design\BRTSt6.dgn

**OTHER CONCRETE STRUCTURE**

5 EPOXY GROUTED 3/4 (M20) ANCHOR BOLTS WITH STANDARD WASHERS. AFTER TIGHTENING, CUT THE ANCHOR BOLTS FLUSH WITH NUTS, AND DAMAGE THE NUT TO PREVENT IT FROM LOOSENING.

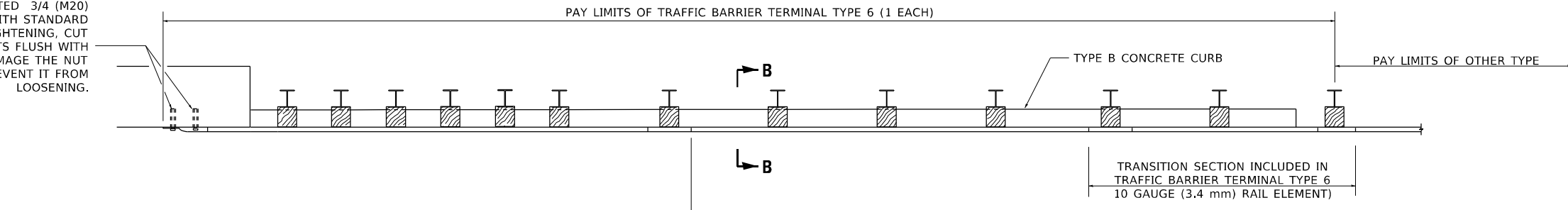

**PLAN**

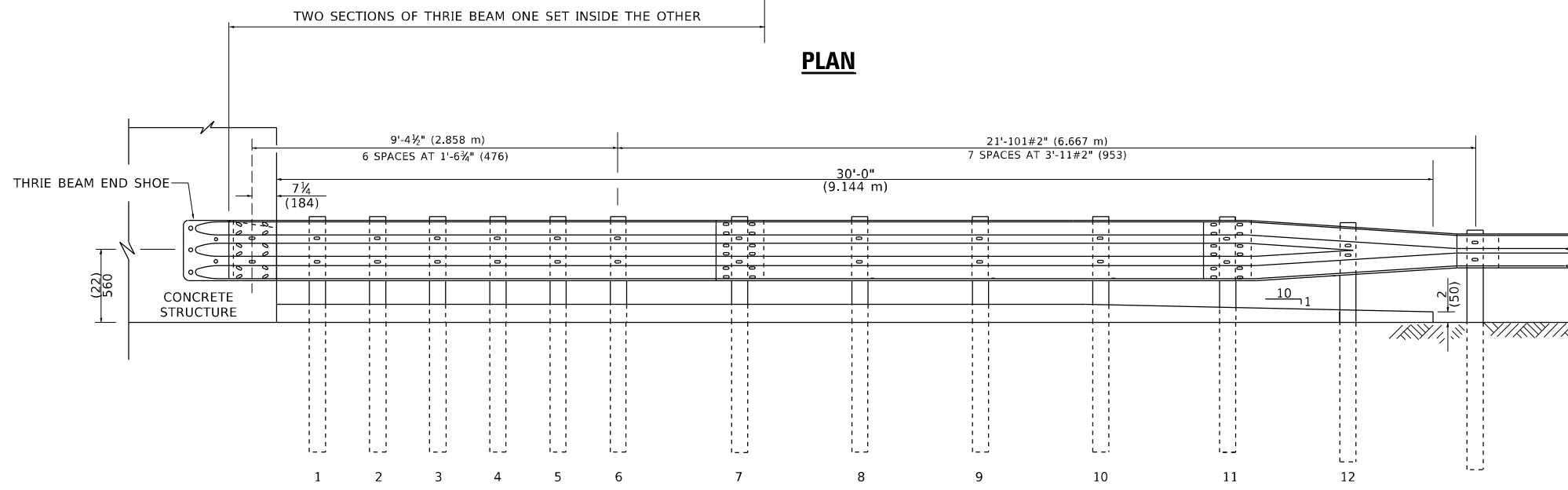

**ELEVATION**

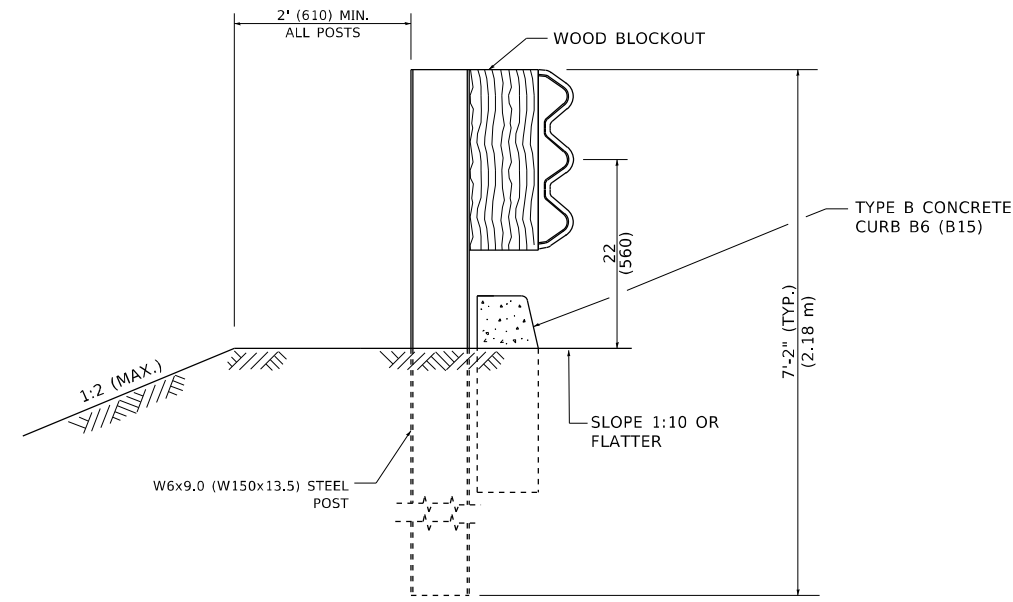

**SECTION B-B**

ILLINOIS STATE STANDARD:  
631031-05 02/19/2008

MODEL: Default  
FILE: \\nafe\p\build\paw\_bentley.com\P\W\DOT\Documents\DOT Office\Drawings\1\Project\126122\CADD\Drawings\Design\B6T6.dgn

USER NAME = Rodrigo.Ledezma	DESIGNED -	REVISED -
	DRAWN -	REVISED - 631031-05 02/19/2008
PLOT SCALE = 100,0000' / in.	CHECKED -	REVISED -
PLOT DATE = 7/7/2022	DATE -	REVISED -

**STATE OF ILLINOIS  
DEPARTMENT OF TRANSPORTATION**

**TYPE 6 TERMINAL  
FOR USE WITH 21" HIGH SPBGR**

SCALE: NONE SHEET 2 OF 3 SHEETS STA. TO STA.

F.A. RTE.	SECTION	COUNTY	TOTAL SHEETS	SHEET NO.
VAR	2022 GUARDRAIL 01	VARIOUS	32	25
<b>BM 22</b>		CONTRACT NO. 62T90		
ILLINOIS FED. AID PROJECT				

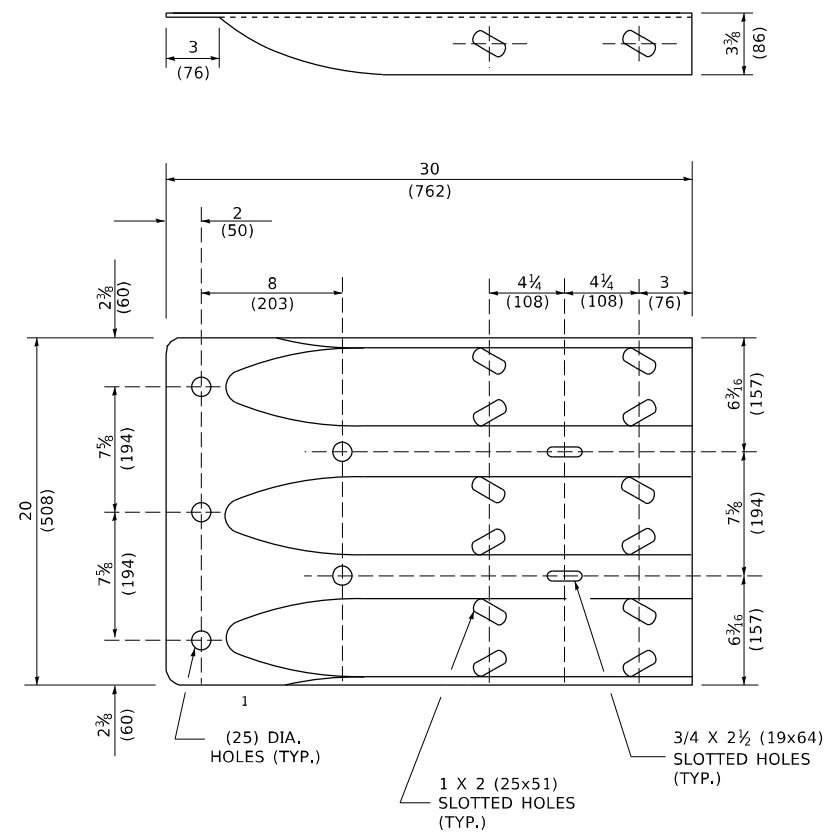

**THRIE BEAM END SHOE DETAIL**

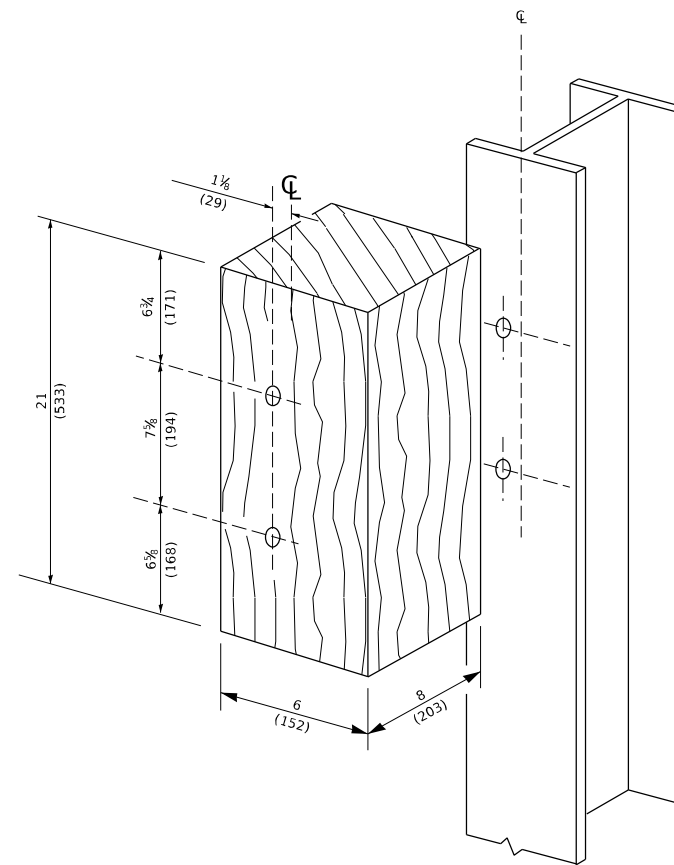

**POSTS 1-11 WOOD BLOCKOUT DETAIL**

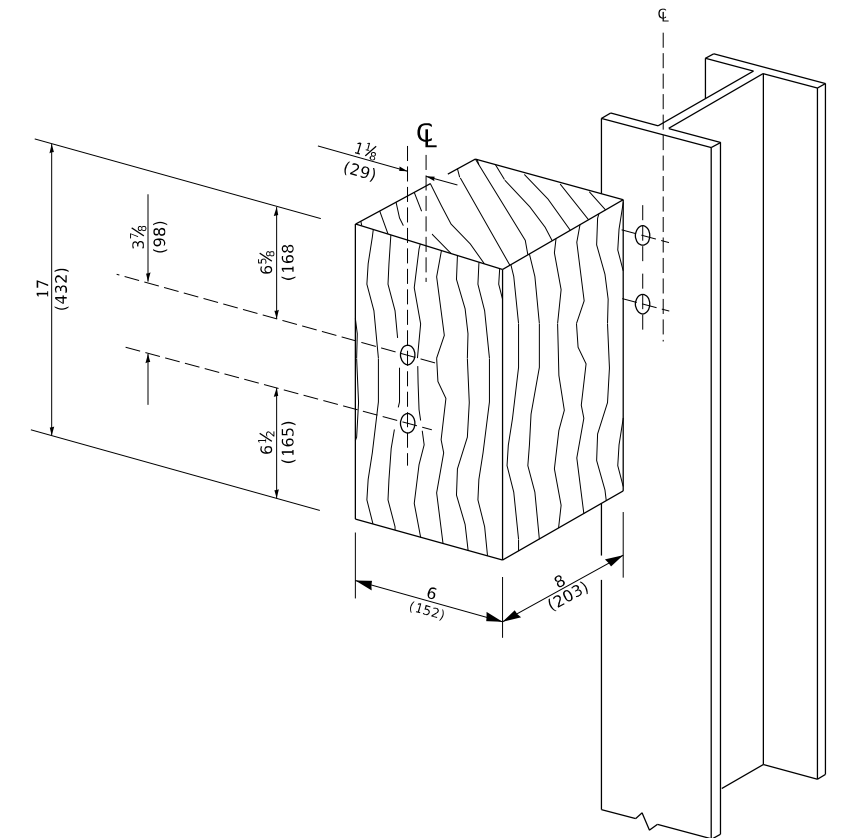

**POST 12 WOOD BLOCKOUT DETAIL**

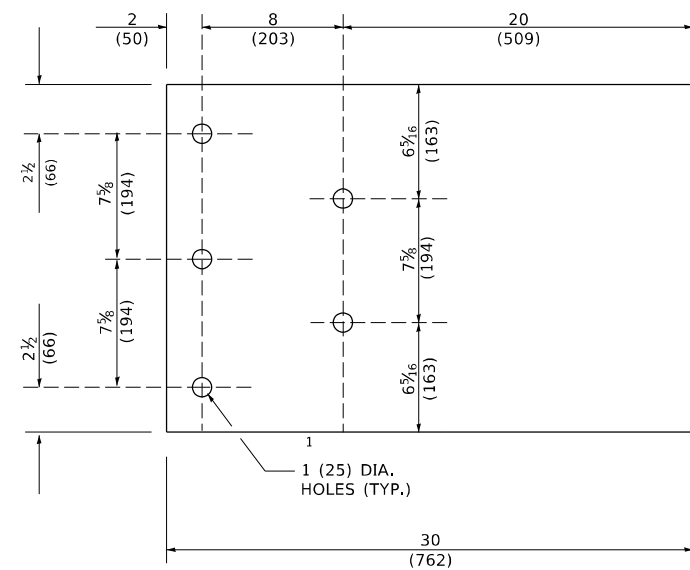

**PARAPET WOOD BLOCK-OUT DETAIL**

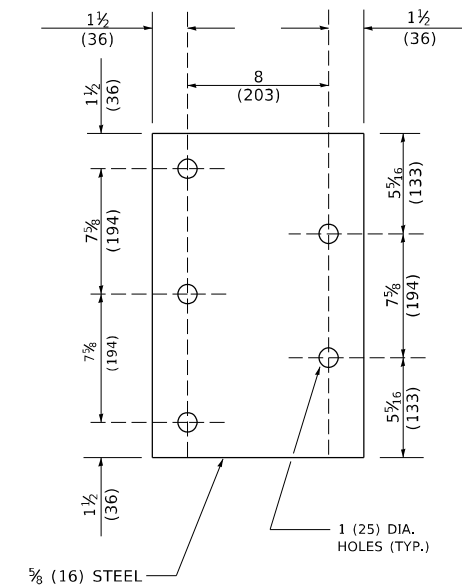
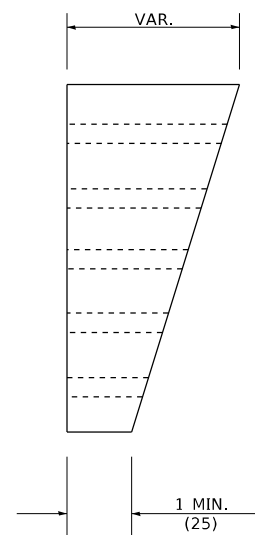

**PARAPET STEEL BEARING PLATE DETAIL**

(5 EACH INDIVIDUAL 5X5X 5/16 (125x125x16) STEEL PLATES WITH CENTERED 1 (25) HOLES MAY BE SUBSTITUTED FOR THE PLATE SHOWN.)

ILLINOIS STATE STANDARD:  
631031-05 02/19/2008

USER NAME = Rodrigo.Ledezma	DESIGNED -	REVISED -
DRAWN -	REVISOR - 631031-05 02/19/2008	
PLOT SCALE = 100,0000' / in.	CHECKED -	REVISED -
PLOT DATE = 7/7/2022	DATE -	REVISED -

**STATE OF ILLINOIS  
DEPARTMENT OF TRANSPORTATION**

**TYPE 6 TERMINAL  
FOR USE WITH 21" HIGH SPBGR**

SCALE: NONE SHEET 3 OF 3 SHEETS STA. TO STA.

F.A. RTE.	SECTION	COUNTY	TOTAL SHEETS	SHEET NO.
VAR	2022 GUARDRAIL 01	VARIOUS	32	26
<b>BM 22</b>			CONTRACT NO.	62T90
ILLINOIS FED. AID PROJECT				

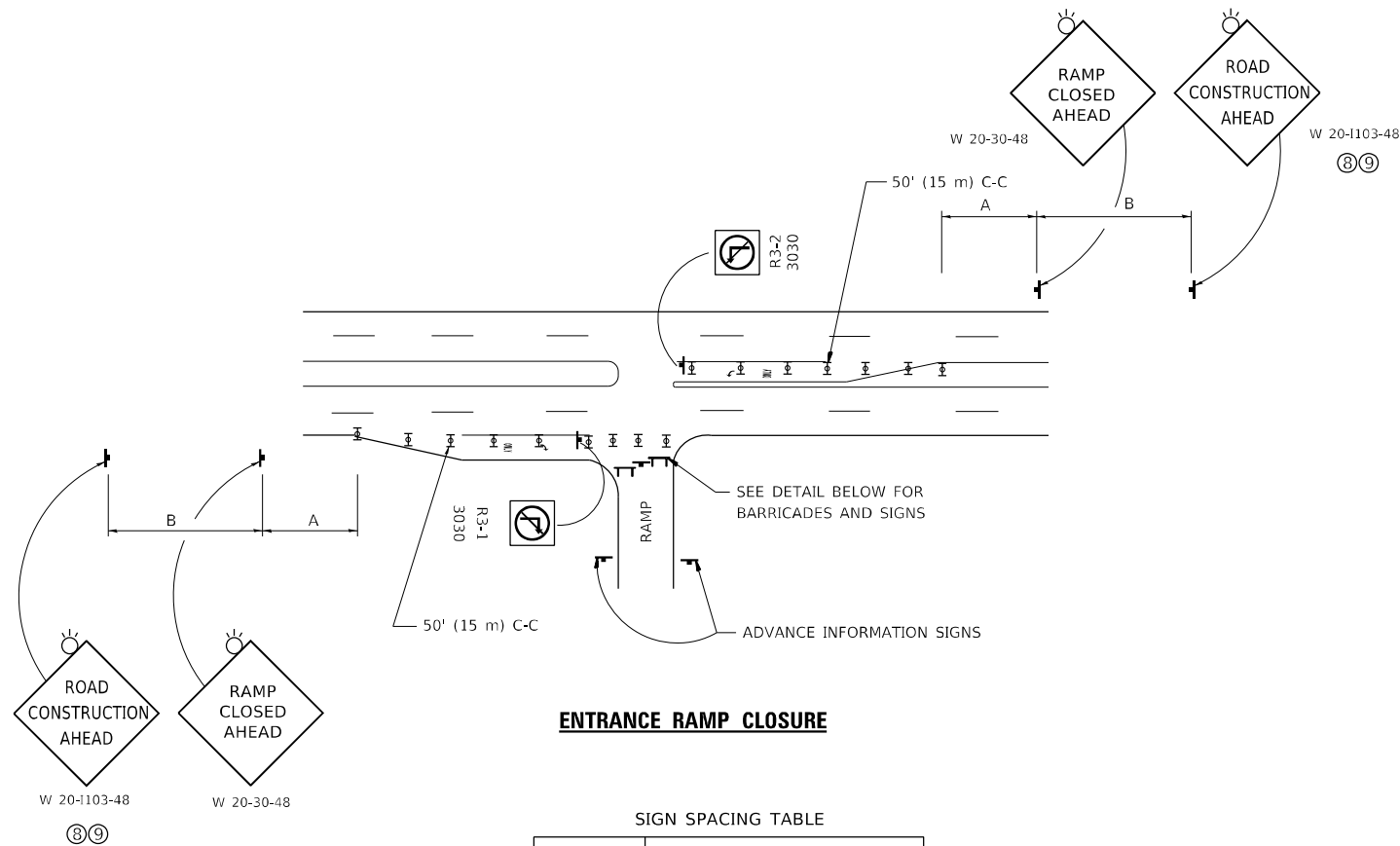

**ENTRANCE RAMP CLOSURE**

SIGN SPACING TABLE

FACILITY	DISTANCE BETWEEN SIGNS	
	A	B
EXPRESSWAY >24 HOURS	1000' (300 m)	1500' (450 m)
EXPRESSWAY ≤24 HOURS	500' (150 m)	500' (150 m)
ARTERIAL 55 MPH	500' (150 m)	500' (150 m)
ARTERIAL 50-45 MPH	350' (100 m)	350' (100 m)
ARTERIAL <45 MPH	200' (60 m)	200' (60 m)

DISTANCES MAY BE SHORTENED DEPENDING UPON THE PROXIMITY OF ADJACENT RAMPS OR INTERSECTIONS.

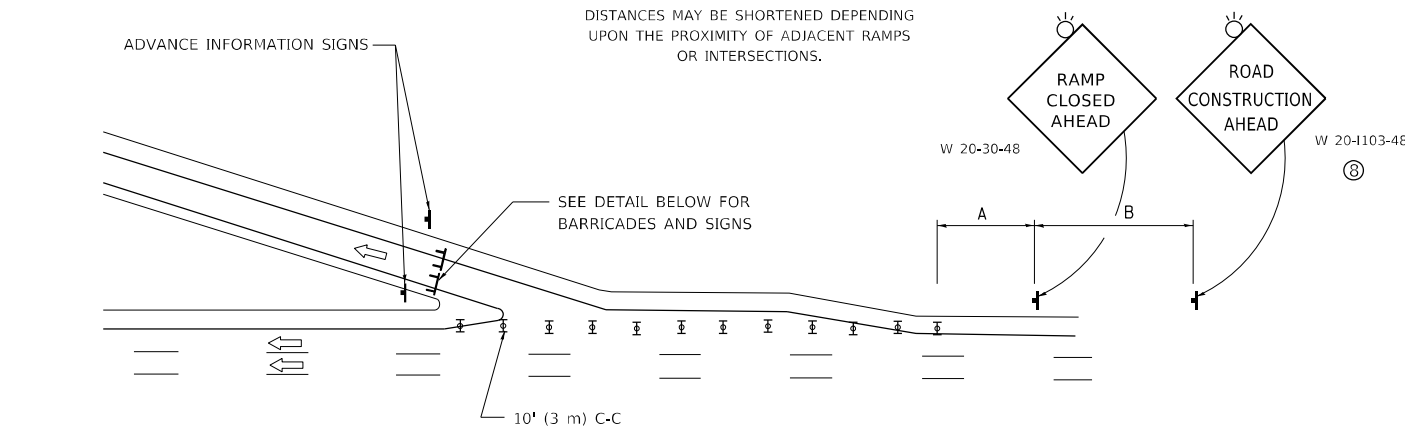

**EXIT RAMP CLOSURE**

**SYMBOLS**

- ▬ TYPE II BARRICADE OR DRUM
- ▬ TYPE III BARRICADE WITH 2 FLASHING LIGHTS

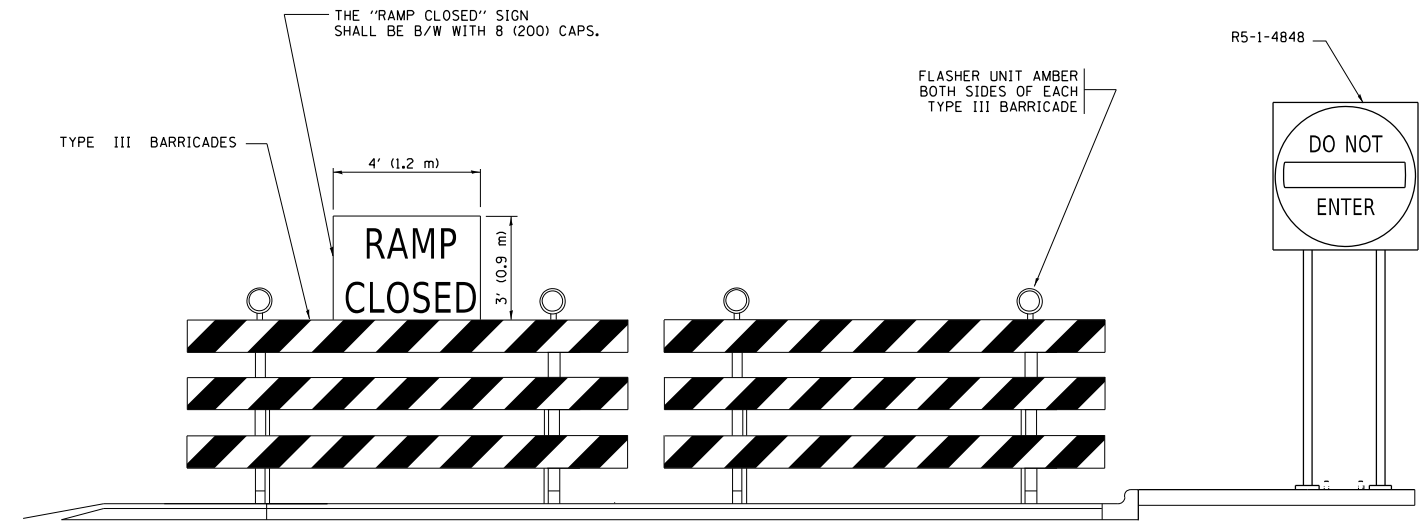

**DETAIL FOR REQUIRED BARRICADES & SIGNS**

**RAMP CLOSURE ADVANCE WARNING SIGN**

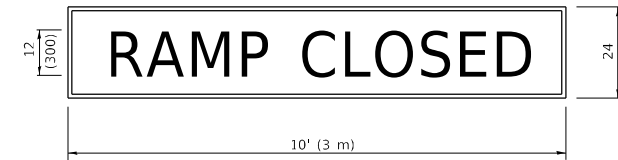

BLACK LEGEND ON ORANGE BACKGROUND MOUNTED DIAGONALLY E MOD FONT 1 (25) BORDER

THESE SIGNS ARE REQUIRED ON ALL THE EXIT GUIDE SIGNS FOR EXIT RAMPS THAT WILL BE CLOSED FOR MORE THAN FOUR (4) CONSECUTIVE DAYS.

THESE SIGNS ARE REQUIRED ON BOTH SIDES OF THE RAMP, MINIMUM OF 1 WEEK IN ADVANCE OF THE CLOSURE.

THESE SIGNS SHALL BE FABRICATED AND PAID FOR ACCORDING TO THE TEMPORARY INFORMATION SIGNING SPECIAL PROVISION

**RAMP CLOSURE ADVANCE INFORMATION SIGN**

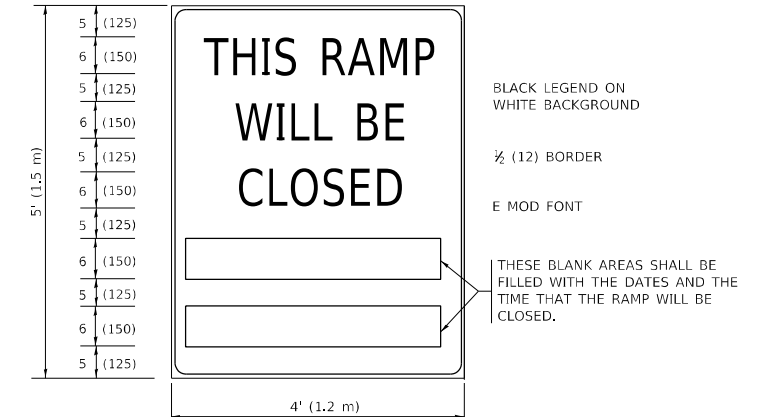

**GENERAL NOTES:**

- ① CONES MAY BE SUBSTITUTED FOR DRUMS OR TYPE II BARRICADES DURING DAY OPERATIONS. CONES SHALL BE A MINIMUM OF 28 (700) HIGH.
- ② VERTICAL BARRICADES SHALL NOT BE USED FOR RAMP CLOSURES.
- ③ A FLAGGER SHALL BE POSITIONED AT EACH CLOSED RAMP THAT IS OPEN TO CONSTRUCTION VEHICLES, PRECEDED BY A W20-7 FLAGGER WARNING SIGN.
- ④ ALL ROUTE MARKERS AND TRAILBLAZER ASSEMBLIES WHICH DIRECT MOTORISTS TO A CLOSED ENTRANCE RAMP SHALL BE COVERED WHEN THE RAMP IS CLOSED FOR MORE THAN FOUR (4) DAYS.
- ⑤ THE SIGNING AND BARRICADING WHICH IS REQUIRED BY THIS DETAIL SHALL BE INCLUDED IN THE COST OF TRAFFIC CONTROL AND PROTECTION (EXPRESSWAYS).
- ⑥ AUTHORIZATION FROM THE DISTRICT'S BUREAU OF TRAFFIC IS REQUIRED FOR ALL RAMP CLOSURES.
- ⑦ THE RAMP CLOSURE ADVANCE INFORMATION SIGNS SHALL BE ERECTED IF THE CLOSURE TIME EXCEEDS TWENTY-FOUR (24) HOURS. ADDITIONAL ADVANCE WARNING SIGNS ON EXIT GUIDE SIGNING WILL BE REQUIRED FOR EXIT RAMP CLOSURES THAT EXCEED FOUR (4) DAYS IN LENGTH.
- ⑧ ROAD CONSTRUCTION AHEAD SIGNS MAY BE OMITTED WHEN THIS DETAIL IS USED IN CONJUNCTION WITH OTHER TRAFFIC CONTROL THAT ALREADY INCLUDES A ROAD CONSTRUCTION AHEAD SIGN.
- ⑨ ARTERIAL ROAD CONSTRUCTION AHEAD SIGNS SHALL BE INSTALLED ON THE LEFT SIDE OF TRAFFIC IF THE MEDIAN IS MORE THAN 10 FT WIDE.

ALL DIMENSIONS ARE IN INCHES (MILLIMETERS) UNLESS OTHERWISE SHOWN.

MODEL: Default  
FILE NAME: p:\bulletect-pw-beadefy.com\FW\DOT\Documents\DOT Office\Dir\drct\_11\project\1216122\CADD\DATA\Design\BRTS\Std.dgn

USER NAME = Rodrigo.Ledezma	DESIGNED - D.W.S.	REVISED - S.P.B._01-07
PLOT SCALE = 100,0000' / in.	DRAWN -	REVISED - S.P.B._12-09
PLOT DATE = 7/7/2022	CHECKED -	REVISED - M.D._06-13
	DATE - 02-83	REVISED - M.D._01-18

**STATE OF ILLINOIS  
DEPARTMENT OF TRANSPORTATION**

**ENTRANCE\_AND\_EXIT\_RAMP  
CLOSURE\_DETAILS**

SCALE: NONE SHEET 1 OF 1 SHEETS STA. TO STA.

F.A. RTE.	SECTION	COUNTY	TOTAL SHEETS	SHEET NO.
VAR	2022 GUARDRAIL 01	VARIOUS	32	27
<b>TC-08</b>		CONTRACT NO. 62T90		
ILLINOIS		FED. AID PROJECT		

# SINGLE LANE WEAVE

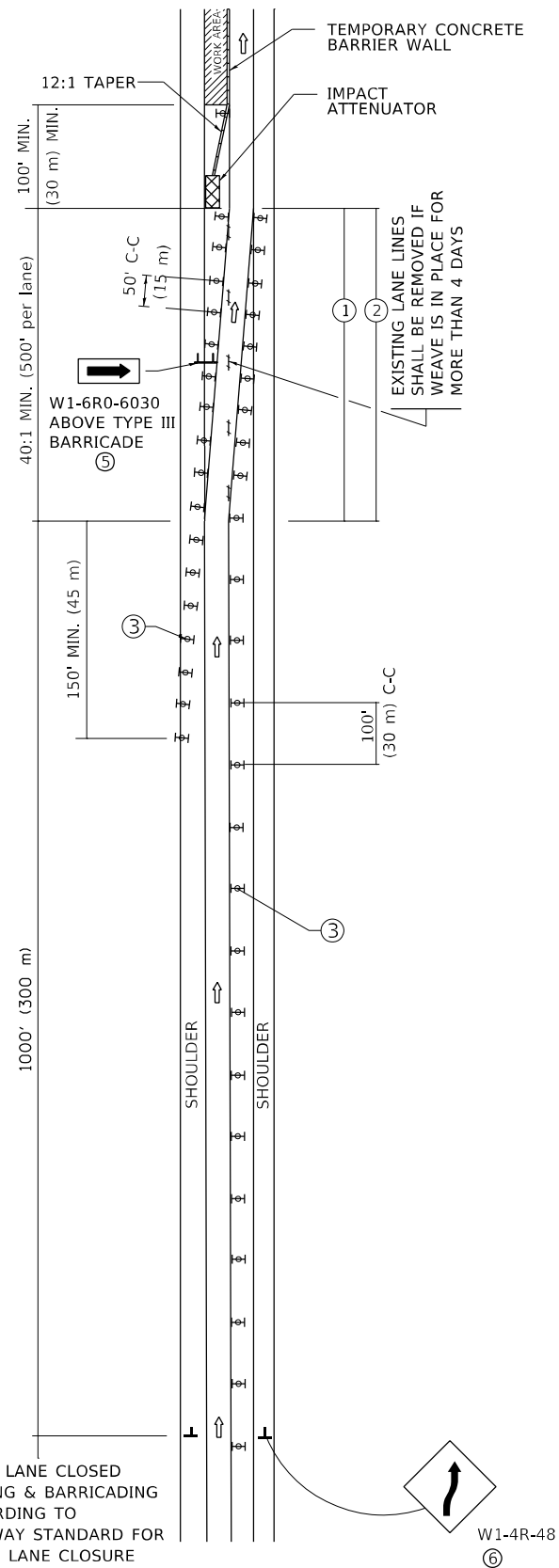

# MULTI-LANE WEAVE

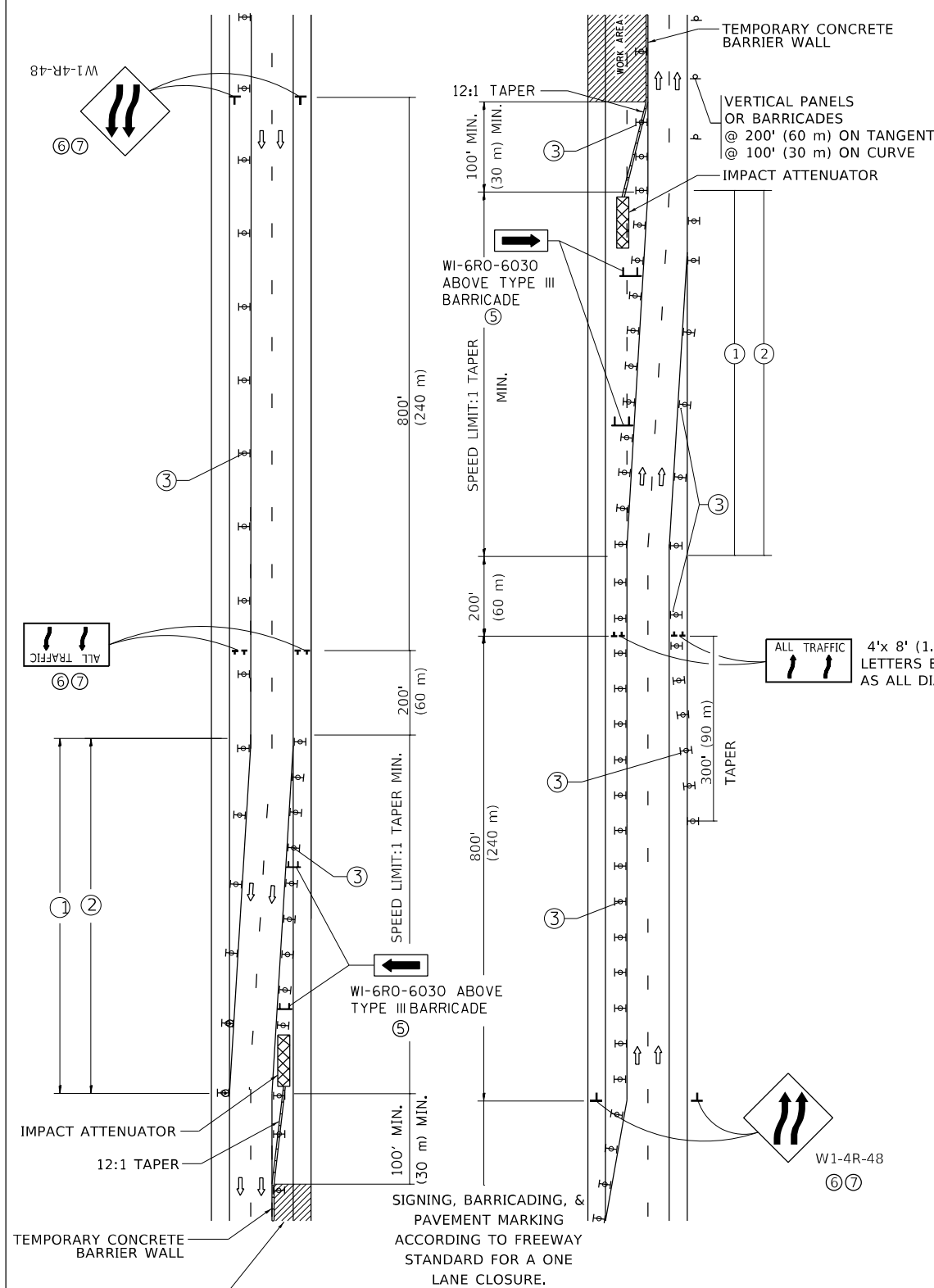

### GENERAL NOTES:

- ① EXISTING CONFLICTING PAVEMENT MARKING LINES SHALL BE REMOVED. PAVEMENT MARKING REMOVAL SHALL NOT BE REQUIRED FOR SINGLE LANE WEAVES UNDER 4 DAYS IN DURATION.
- ② CONTINUOUS REFLECTIVE TEMPORARY PAVEMENT MARKING TAPE SHALL BE PLACED THROUGHOUT THE TAPER AND FOR 300' (90 m) ALONG SIDE THE WORK AREA WHERE THE CLOSURE TIME IS GREATER THAN FOURTEEN DAYS. THE LEFT EDGE LINE SHALL BE YELLOW AND THE RIGHT EDGE LINE SHALL BE WHITE. FOR MULTI-LANE WEAVES LANE LINES SHALL BE 5 INCH, 10'-30' (3 m-9 m) SKIP DASH, WHITE.
- ③ PLASTIC DRUMS WITH STEADY BURN LIGHTS AT 50' (15 m) C-C SPACING IN TAPERS AND 100' (30 m) C-C SPACING IN TANGENTS.
- ④ ALL SIGNS SHALL BE POST MOUNTED IF THE CLOSURE TIME EXCEEDS FOUR DAYS.
- ⑤ TYPE III BARRICADES MAY BE OMITTED FOR SINGLE-LANE WEAVES UNDER 24-HOURS IN DURATION. W1-6 SIGNS WILL STILL BE REQUIRED. IF THE WIDTH OF OFFSET IS LESS THAN 6' THEN THE TYPE III BARRICADE WITH ATTACHED ARROW SIGN PANEL CAN BE ELIMINATED IN THE TAPER AREAS.
- ⑥ WHEN THE LENGTH OF THE SHIFTED SEGMENT (DISTANCE BETWEEN WEAVE POINTS) IS LESS THAN 1500', DOUBLE REVERSE CURVE SIGNS (W24-1) SHOULD BE USED INSTEAD OF THE REVERSE CURVE (W1-4) SIGNS. ARROWS ON THE 4'X8' "ALL TRAFFIC" SIGNS SHALL BE THE SAME SHAPE.
- ⑦ THE NUMBER OF ARROWS ON THESE SIGNS SHALL MATCH THE NUMBER OF LANES OPEN TO TRAFFIC.

### SYMBOLS

- DIRECTION OF TRAFFIC
- WORK AREA
- SIGN ON PORTABLE OR PERMANENT SUPPORT
- TYPE II BARRICADE OR DRUM WITH MONO-DIRECTIONAL STEADY BURNING LIGHT
- TEMPORARY CONCRETE BARRIER WALL
- IMPACT ATTENUATOR
- W1-4R-48
- W24-1-48

ALL DIMENSIONS ARE IN INCHES (MILLIMETERS) UNLESS OTHERWISE SHOWN

MODEL: Default  
FILE NAME: p:\bulletect-pw-bentley.com\P\DOT\Documents\DOT Office\District: 11\project\1216122\Cadd\data\Design\BRT5td.dgn

USER NAME = Rodrigo.Ledezma	DESIGNED - D.W.S.	REVISED - J.A.F. 02-06
PLOT SCALE = 100,0000' / in.	CHECKED -	REVISED - S.P.B. 01-07
PLOT DATE = 7/7/2022	DATE - 02-87	REVISED - S.P.B. 12-09
		REVISED - M.D. 06-13

**STATE OF ILLINOIS  
DEPARTMENT OF TRANSPORTATION**

**TRAFFIC CONTROL DETAILS FOR  
FREEWAY SINGLE & MULTI-LANE WEAVE**

SCALE: NONE SHEET 1 OF 1 SHEETS STA. TO STA.

F.A. RTE.	SECTION	COUNTY	TOTAL SHEETS	SHEET NO.
VAR	2022 GUARDRAIL 01	VARIOUS	32	28
TC-09		CONTRACT NO. 62T90		
ILLINOIS FED. AID PROJECT				

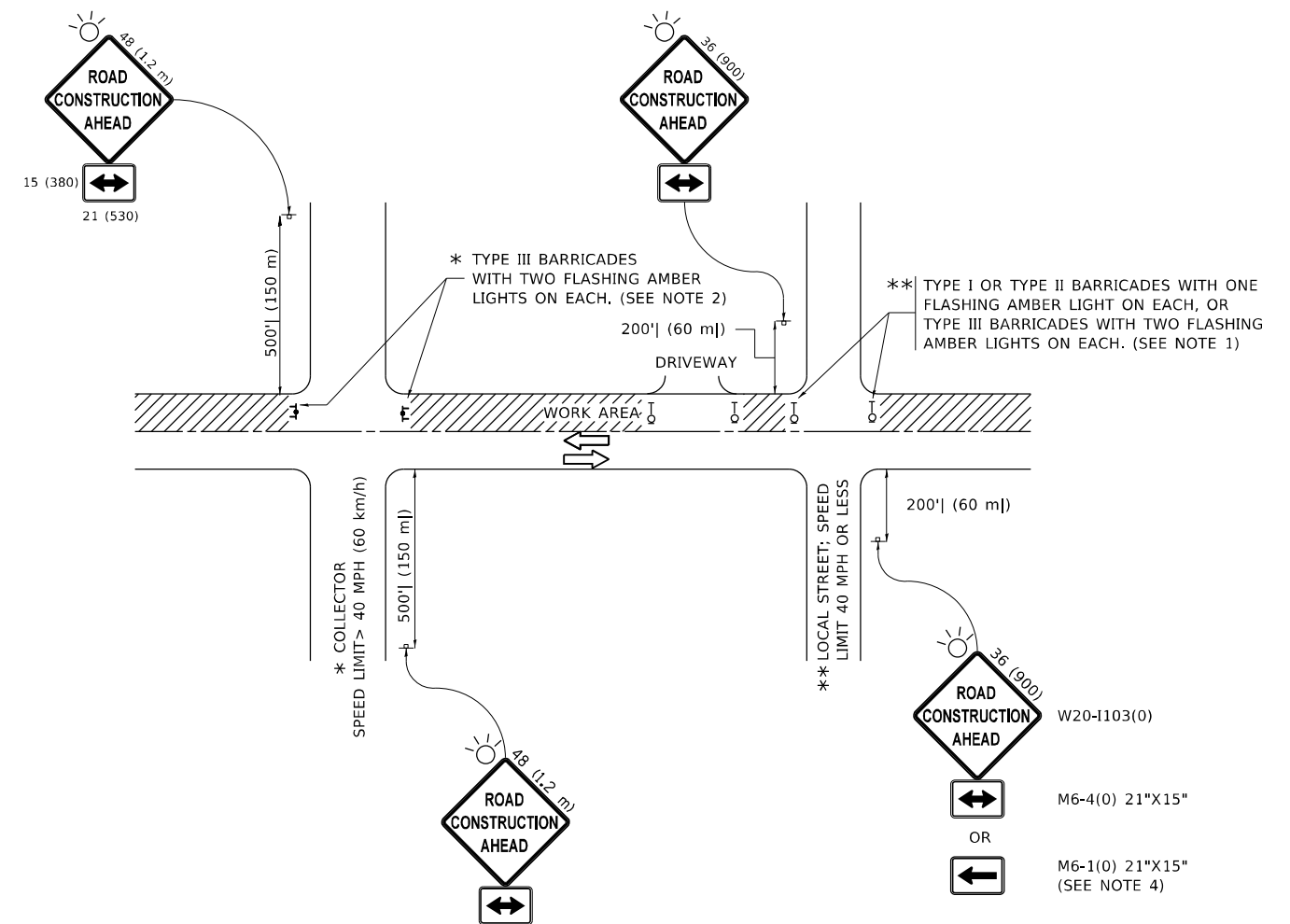

**NOTES:**

- SIDE ROAD WITH A SPEED LIMIT OF 40 MPH (60 km/h) OR LESS AS SHOWN ON THE DRAWING AND AS DIRECTED BY THE ENGINEER:
  - ONE "ROAD CONSTRUCTION AHEAD" SIGN 36 x 36 (900x900) WITH A FLASHER MOUNTED ON IT APPROXIMATELY 200' (60 m) IN ADVANCE OF THE MAIN ROUTE.
  - THE CLOSED PORTION OF THE MAIN ROUTE SHALL BE PROTECTED BY BLOCKING WITH TYPE I, TYPE II OR TYPE III BARRICADES, 1/3 OF THE CROSS SECTION OF THE CLOSED PORTION.
- SIDE ROAD WITH A SPEED LIMIT GREATER THAN 40 MPH (60 km/h) AS SHOWN ON THE DRAWING AND AS DIRECTED BY THE ENGINEER:
  - ONE "ROAD CONSTRUCTION AHEAD" SIGN 48 x 48 (1.2 m x 1.2 m) WITH A FLASHER MOUNTED ON IT APPROXIMATELY 500' (150 m) IN ADVANCE OF THE MAIN ROUTE.
  - THE CLOSED PORTION OF THE MAIN ROUTE SHALL BE PROTECTED BY BLOCKING WITH TYPE III BARRICADES, 1/2 OF THE CROSS SECTION OF THE CLOSED PORTION.
- CONES MAY BE SUBSTITUTED FOR BARRICADES OR DRUMS AT HALF THE SPACING DURING DAY OPERATIONS. CONES SHALL BE A MINIMUM OF 28 (710) IN HEIGHT.
- SIGNING AND THE WORK ZONE, A SINGLE HEADED ARROW (M6-1) SHALL BE USED IN LIEU OF THE DOUBLE HEADED ARROW (M6-4).
- WHEN THE SIDE ROAD LIES BETWEEN THE BEGINNING OF THE MAINLINE AND THE WORK ZONE, A SINGLE HEADED ARROW (M6-1) SHALL BE USED IN LIEU OF THE DOUBLE HEADED ARROW (M6-4).
- WHEN WORK IS BEING PERFORMED ON A SIDE ROAD OR DRIVEWAY, FOLLOW THE APPLICABLE STANDARD(S). THE DIRECTIONAL ARROW (M6-1 OR M6-4) SHALL BE COVERED OR REMOVED WHEN NO LONGER CONSISTENT WITH THE TRAFFIC CONTROL SET-UP.
- ADVANCE WARNING SIGNS ARE TO BE OMITTED ON DRIVEWAYS UNLESS OTHERWISE SPECIFIED IN THE PLANS OR BY THE ENGINEER.
- THE TRAFFIC CONTROL AND PROTECTION FOR SIDE ROADS, INTERSECTIONS, AND DRIVEWAYS SHALL BE INCLUDED IN THE COST OF SPECIFIED TRAFFIC CONTROL STANDARDS OR ITEMS.

All dimensions are in inches (millimeters) unless otherwise shown.

MODEL: Default  
FILE NAME: p:\ultra-caw-beach\paw.com\PIV\DOT\Documents\DOT Office\Dir\rdet - 1\Project\10126122\CADD\DATA\Design\BATS\Std.dgn

USER NAME = Rodrigo.Ledezma	DESIGNED - L.H.A.	REVISED - A. HOUSEH 10-15-96
PLOT SCALE = 100,0000' / in.	CHECKED -	REVISED - T. RAMMACHER 01-06-00
PLOT DATE = 7/7/2022	DATE - 06-89	REVISED - A. SCHUETZE 07-01-13
		REVISED - A. SCHUETZE 09-15-16

**STATE OF ILLINOIS  
DEPARTMENT OF TRANSPORTATION**

**TRAFFIC CONTROL AND PROTECTION FOR  
SIDE ROADS, INTERSECTIONS, AND DRIVEWAYS**

SCALE: NONE SHEET 1 OF 1 SHEETS STA. TO STA.

F.A. RTE.	SECTION	COUNTY	TOTAL SHEETS	SHEET NO.
VAR	2022 GUARDRAIL 01	VARIOUS	32	29
<b>TC-10</b>			CONTRACT NO. 62T90	
ILLINOIS FED. AID PROJECT				

# TURN BAY ENTRANCE AT START OF LANE CLOSURE TAPER

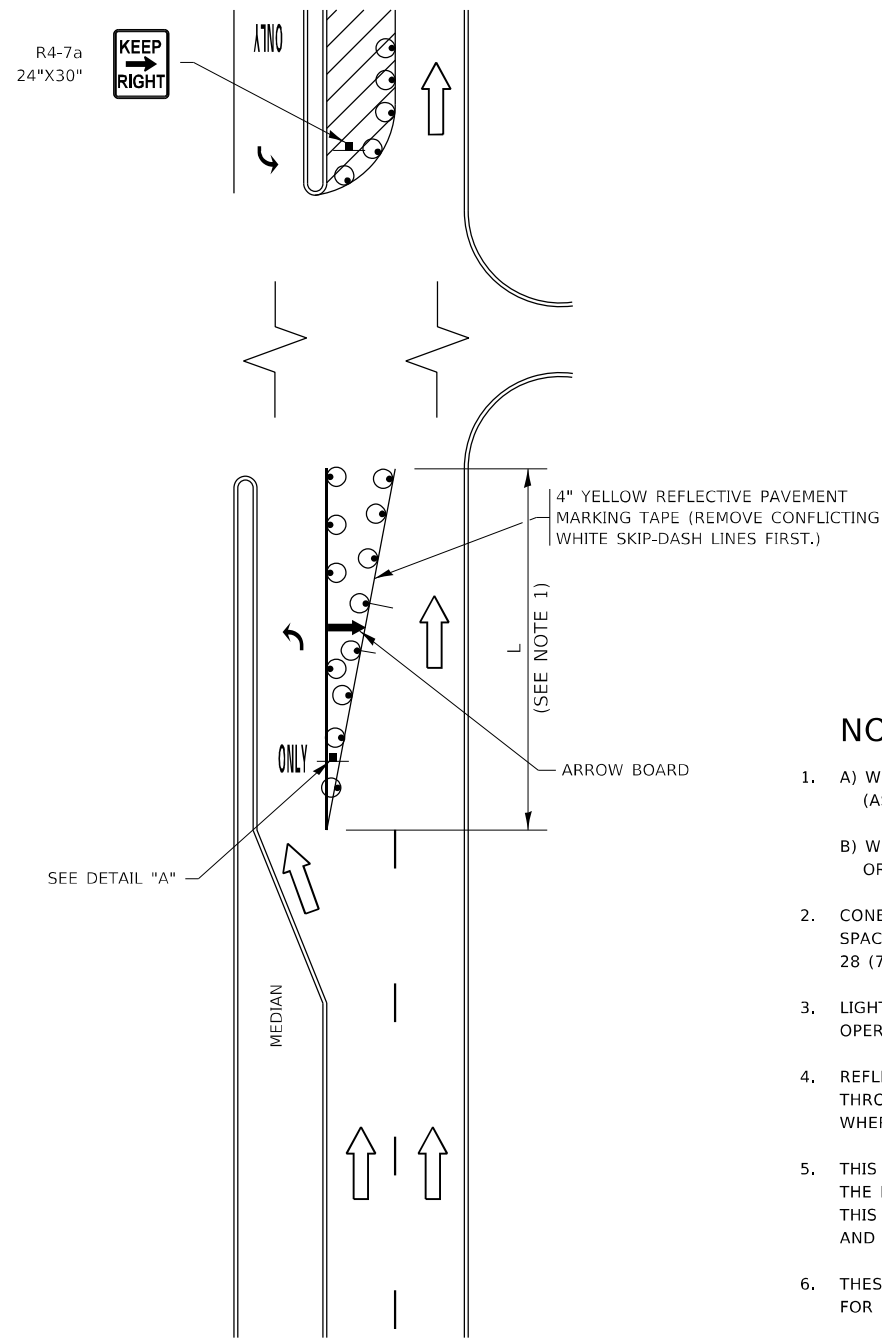

**FIGURE 1**

# TURN BAY ENTRANCE WITHIN A LANE CLOSURE

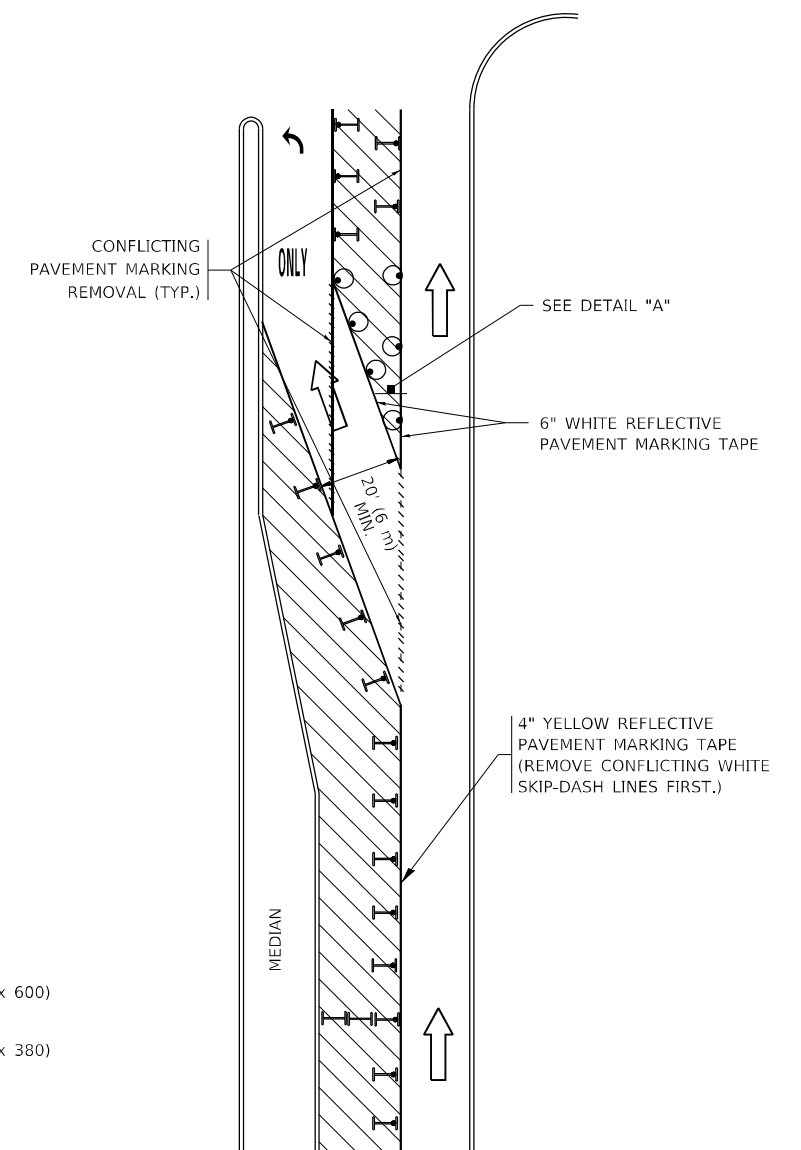

**FIGURE 2**

### LEGEND

- WORK AREA
- LANE OPEN TO TRAFFIC
- ARROW BOARD
- TYPE I OR II BARRICADE OR DRUM WITH STEADY BURN LIGHT
- DRUM WITH STEADY BURN LIGHT
- SIGN ASSEMBLY
- TYPE I OR II CHECK BARRICADE WITH FLASHING LIGHT

### NOTES:

1. A) WHEN "L" IS  $\leq$  THE STORAGE LENGTH OF THE TURN LANE (AS SHOWN IN FIG. 1), USE FIGURE 1.  
 B) WHEN "L" IS  $>$  THE STORAGE LENGTH OF THE TURN LANE OR THE TURN LANE IS WITHIN THE LANE CLOSURE, USE FIGURE 2.
2. CONES MAY BE SUBSTITUTED FOR BARRICADES OR DRUMS AT HALF THE SPACING DURING DAY OPERATIONS. CONES SHALL BE A MINIMUM OF 28 (710) IN HEIGHT.
3. LIGHTS WILL NOT BE REQUIRED ON BARRICADES OR DRUMS FOR DAY OPERATIONS. ALL LIGHTS SHALL BE MONODIRECTIONAL.
4. REFLECTIVE TEMPORARY PAVEMENT MARKINGS SHALL BE PLACED THROUGHOUT THE BARRICADED AREAS OF EACH TURN BAY AS SHOWN WHERE THE CLOSURE TIME IS GREATER THAN FOURTEEN (14) DAYS.
5. THIS APPLICATION ALSO APPLIES WHEN WORK IS BEING PERFORMED IN THE RIGHT LANE(S) AND THE RIGHT TURN BAY IS TO REMAIN OPEN. UNDER THIS CONDITION, "RIGHT TURN LANE" R3-1100R 24 x 24 (600 x 600) AND M6-2R 21 x 15 (530 x 380) SHALL BE USED.
6. THESE CONTROLS SHALL SUPPLEMENT MAINLINE TRAFFIC CONTROL FOR LANE CLOSURES.
7. THE SIGNS SHALL BE MOUNTED ABOVE THE BARRICADES/DRUMS ON SEPARATE SIGN SUPPORTS THAT MEET NCHRP 350 OR MASH REQUIREMENTS.
8. TRAFFIC CONTROL AND PROTECTION AT TURN BAYS (TO REMAIN OPEN TO TRAFFIC) SHALL BE INCLUDED IN THE COST OF SPECIFIED TRAFFIC CONTROL STANDARDS OR ITEMS.

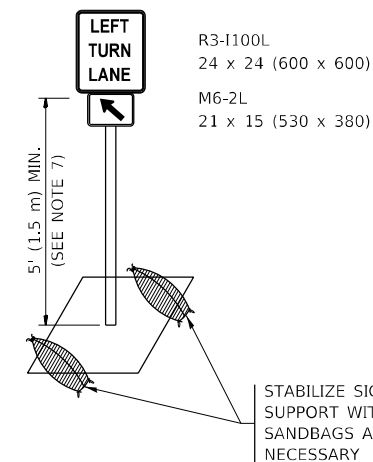

**DETAIL A**

All dimensions are in inches (millimeters) unless otherwise shown.

MODEL: Default FILE NAME: p:\project\paw\_bentley.com\p\w\dot\Documents\DOT\_Offices\Dir\dtdt\_1\Project\10126122\CADD\data\Design\BartSt.dgn

USER NAME = Rodrigo.Ledezma	DESIGNED - T. RAMMACHER 09-08-94	REVISED - R. BORO 09-14-09
	DRAWN - A. HOUSEH 11-07-95	REVISED - A. SCHUETZE 07-01-13
PLOT SCALE = 100,0000' / in.	CHECKED - A. HOUSEH 10-12-96	REVISED - A. SCHUETZE 09-15-16
PLOT DATE = 7/7/2022	DATE - T. RAMMACHER 01-06-00	REVISED -

**STATE OF ILLINOIS  
DEPARTMENT OF TRANSPORTATION**

**TRAFFIC CONTROL AND PROTECTION AT TURN BAYS  
(TO REMAIN OPEN TO TRAFFIC)**

SCALE: NONE SHEET 1 OF 1 SHEETS STA. TO STA.

F.A. RTE.	SECTION	COUNTY	TOTAL SHEETS	SHEET NO.
VAR	2022 GUARDRAIL 01	VARIOUS	32	30
TC-14		CONTRACT NO.	62T90	
ILLINOIS FED. AID PROJECT				



**PARTIAL RAMP CLOSURE DETAILS**

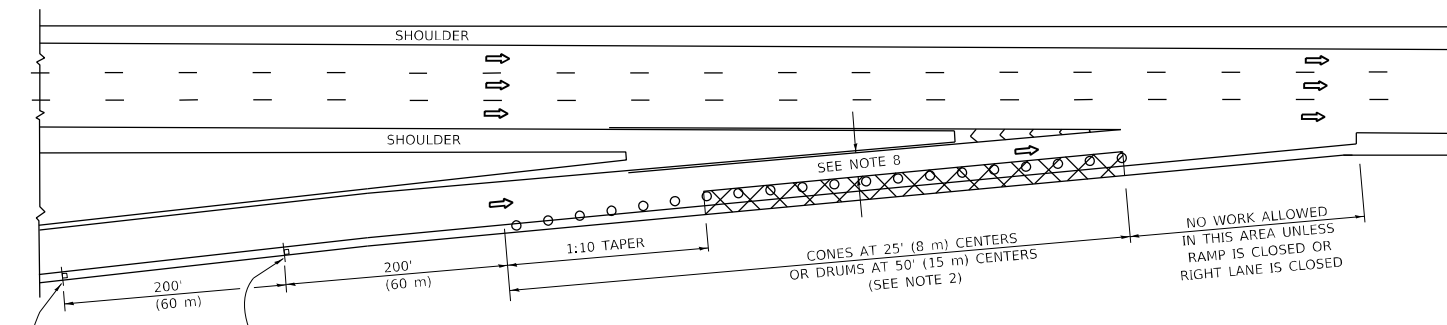

**TYPICAL ENTRANCE RAMP**

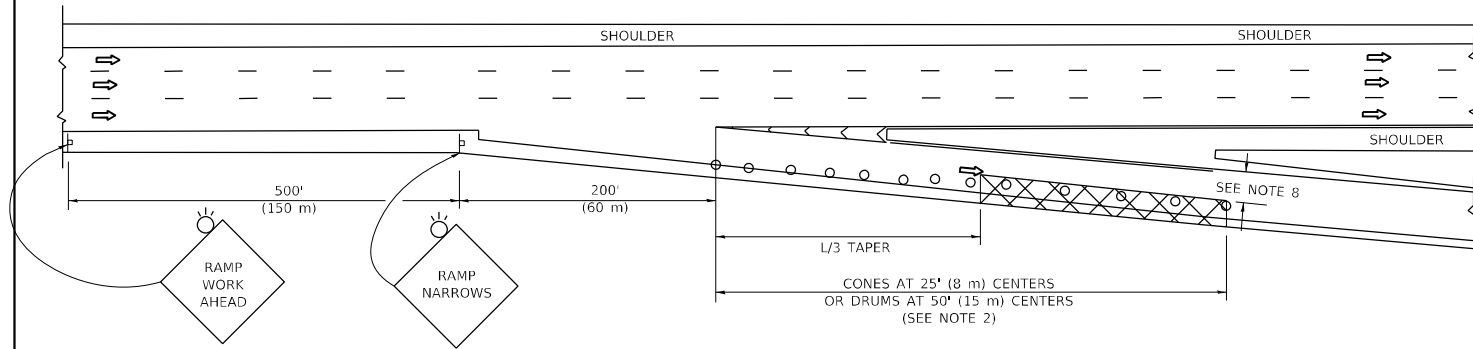

**TYPICAL EXIT RAMP**

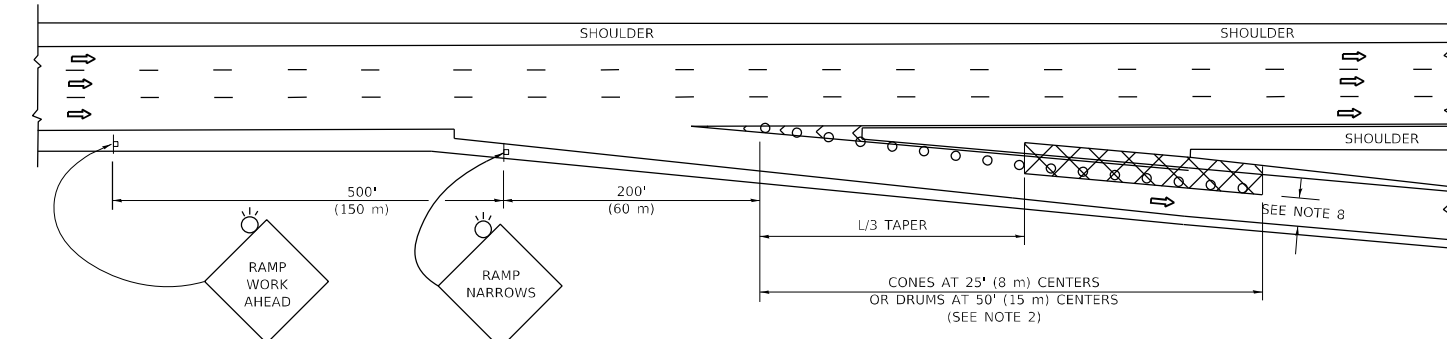

**TYPICAL EXIT RAMP**

**SYMBOLS**

- ACTIVE WORK AREA
- SIGN ON PORTABLE OR PERMANENT SUPPORT
- FLAGGER WITH CONTROL SIGN
- TYPE II BARRICADE OR DRUM
- CONE, DRUM OR BARRICADE
- IMPACT ATTENUATOR OF TYPE AND TEST LEVEL SPECIFIED

**GENERAL NOTES:**

- THE "L" DISTANCE EQUALS:  

$L = \frac{S^2}{200}$	$L = \frac{S^2}{3.28}$
$L = \frac{S^2}{200}$	$L = \frac{S^2}{3.28}$

W = WIDTH OF OFFSET IN FEET (METERS)  
 S = NORMAL POSTED SPEED MPH (KM/H)
- TYPE II BARRICADES OR DRUMS ARE REQUIRED FOR ALL NIGHTTIME CLOSURES. TYPE II BARRICADES OR DRUMS WITH MONODIRECTIONAL STEADY BURN LIGHTS ARE REQUIRED FOR DELINEATING OBSTACLES, EXCAVATIONS, OR HAZARDS EXCEEDING 100 FT (30m) IN LENGTH AT NIGHT.
- ALL SIGNS SHALL BE POST MOUNTED IF THE CLOSURE TIME EXCEEDS FOUR DAYS.
- FLASHING LIGHTS SHALL BE USED DURING THE HOURS OF DARKNESS AND SHALL BE INSTALLED ABOVE THE FIRST TWO SETS OF SIGNS.

**SHOULDER CLOSURE DETAILS**

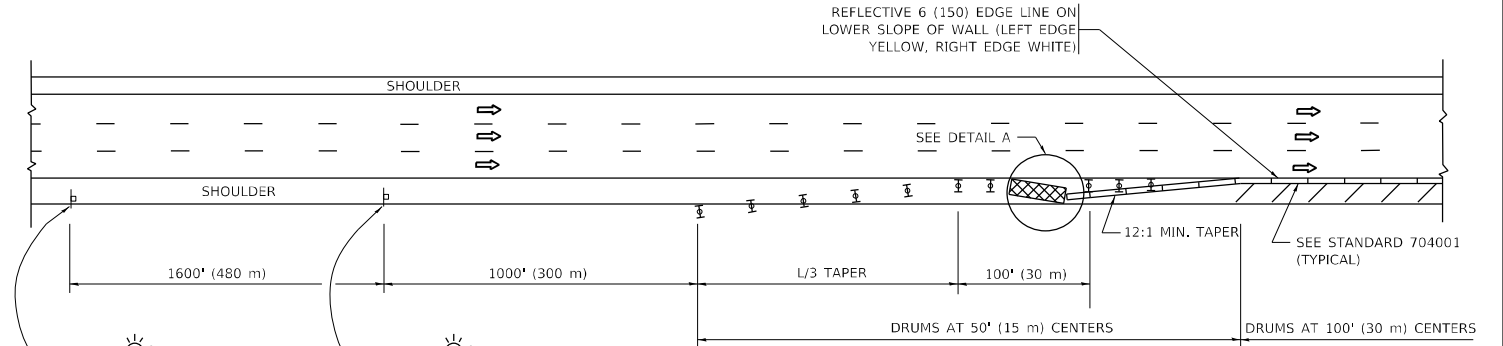

**PERMANENT SHOULDER CLOSURE**

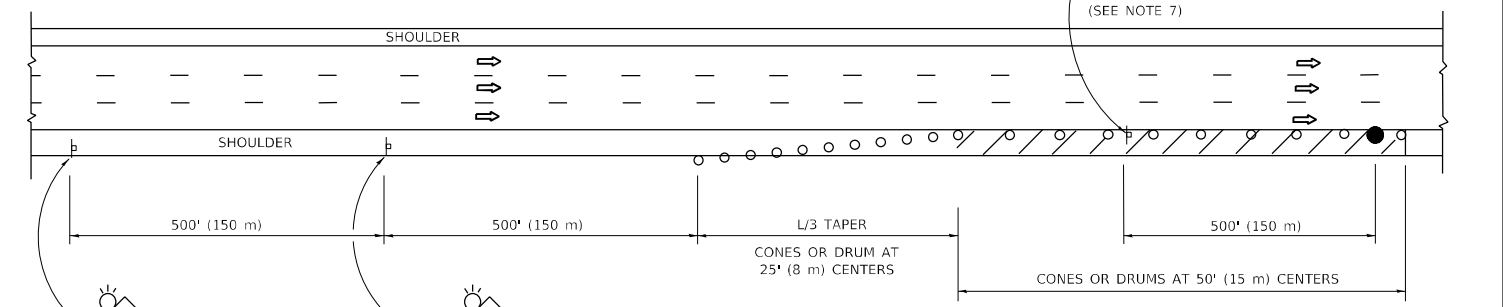

**TEMPORARY SHOULDER CLOSURE**

THIS DETAIL IS USED WHERE:  
 1. VEHICLES, EQUIPMENT, WORKERS OR THEIR ACTIVITIES ENCR OACH IN AN AREA CLOSER THAN 15' (4.5 m) TO THE EDGE OF PAVEMENT FOR A PERIOD IN EXCESS OF 15 MINUTES.



**DETAIL "A"  
IMPACT ATTENUATOR, TEMPORARY  
(SEE NOTE 5)**

- THE IMPACT ATTENUATOR, TEMPORARY IS NOT REQUIRED WHEN THE TEMPORARY CONCRETE BARRIER WALL IS PROTECTED BY OR IS TIED INTO THE EXISTING GUARDRAIL. IF OFFSET IS LESS THAN 5 FEET USE NARROW USE TYPE DEVICE TO MEET NCHRP350/MASH.
- AUTHORIZATION FROM THE DISTRICT'S BUREAU OF TRAFFIC IS REQUIRED FOR ALL FREEWAY CLOSURES.
- THE FLAGGER AND FLAGGER SIGN ARE REQUIRED AT THE ABOVE WORK SITES WHEN:
  - FOUR OR MORE WORK VEHICLES ENTER THE TRAFFIC LANES IN A ONE HOUR PERIOD.
  - THE WORK AVTIVITY REQUIRES FREQUENT ENCR OACHMENT INTO THE LANE OPEN TO TRAFFIC.
 THE FLAGGER SHALL BE STATIONED APPROXIMATELY 100' (30 m) TO 200' (60 m) IN ADVANCE OF THE WORKERS.
- 12' MIN. WIDTH TANGENT SECTION  
16' MIN. WIDTH CURVE SECTION.
- TEMPORARY SHOULDER AND NON-SYSTEM INTERCHANGE PARTIAL RAMP CLOSURES ARE ALLOWED WEEKDAYS BETWEEN 9:00 A.M. AND 3:00 P.M. AND BETWEEN 7:00 P.M. AND 5:00 A.M. OR AS APPROVED BY THE EXPRESSWAY TRAFFIC OPERATIONS ENGINEER. PERMANENT SHOULDER AND PARTIAL RAMP CLOSURES WILL ONLY BE PERMITTED IF CALLED FOR IN THE PLANS OR AS APPROVED BY THE EXPRESSWAY OPERATIONS ENGINEER.

ALL DIMENSIONS ARE IN INCHES (MILLIMETERS) UNLESS OTHERWISE SHOWN.

MODEL: Default  
 FILE NAME: \\pilot\dot\documents\1001\office\dir\refr\1\project\10126122\Cadd\data\Design\BRTS.dgn

USER NAME = Rodrigo.Ledezma	DESIGNED -	REVISED - S.P.B. 12-09
	DRAWN - D.W.S.	REVISED - M.D. 06-13
PLOT SCALE = 100,0000' / in.	CHECKED -	REVISED - M.D. 01-18
PLOT DATE = 7/7/2022	DATE - 11-96	REVISED - M.D. 10-20

**STATE OF ILLINOIS  
DEPARTMENT OF TRANSPORTATION**

**TRAFFIC CONTROL DETAILS FOR FREEWAY  
SHOULDER CLOSURES AND PARTIAL RAMP CLOSURES**

SCALE: NONE SHEET 1 OF 1 SHEETS STA. TO STA.

F.A. RTE.	SECTION	COUNTY	TOTAL SHEETS	SHEET NO.
VAR	2022 GUARDRAIL 01	VARIOUS	32	31
<b>TC-17</b>		CONTRACT NO. 62T90		
ILLINOIS FED. AID PROJECT				

SIGNING FOR FLAGGING OPERATIONS AT WORK ZONE OPENINGS

**WORK ZONE EXIT OPENING**

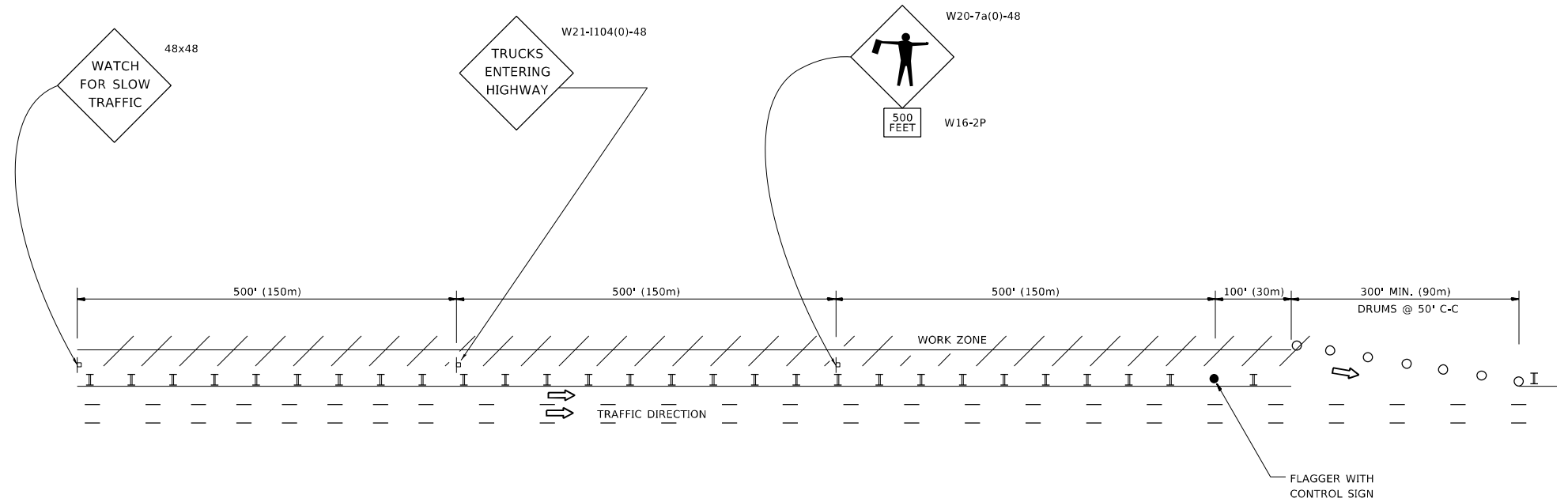

**WORK ZONE ENTRY OPENING**

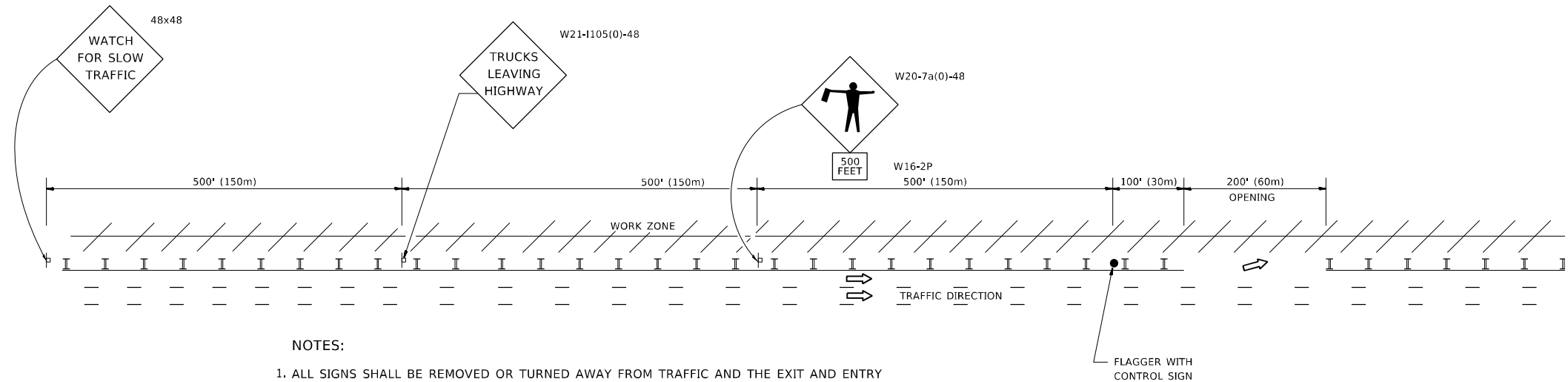

**NOTES:**

1. ALL SIGNS SHALL BE REMOVED OR TURNED AWAY FROM TRAFFIC AND THE EXIT AND ENTRY OPENINGS SHALL BE CLOSED WHEN THE FLAGGING OPERATION CEASES. NON OPERATING EQUIPMENT SHALL COMPLY WITH ARTICLE 701.11
2. WORK ZONE OPENINGS SHALL BE A MINIMUM OF ONE HALF MILE APART AND A MINIMUM OF ONE QUARTER MILE FROM ALL ENTRANCE AND EXIT RAMP.
3. EXITING THE WORK ZONE AT ANY PLACE OTHER THAN AT A WORK ZONE EXIT OPENING WILL BE PROHIBITED.
4. ALL VEHICLES SHALL ENTER THE WORK ZONE AT ENTRY OPENINGS, USING THEIR TURN SIGNALS TO WARN MOTORISTS
5. FLAGGERS SHALL NOT STOP TRAFFIC OR DIRECT TRAFFIC INTO AN ADJACENT LANE.

ALL DIMENSIONS ARE IN INCHES (MILLIMETERS) UNLESS OTHERWISE SHOWN

MODEL: Default  
FILE: \\blmfe-pw-bentley.com\P\W\DOT\Documents\DOT Office\Dir\rdet\_1\Project\126122\CADD\data\Design\BtStEd.dgn

USER NAME = Rodrigo.Ledezma	DESIGNED -	REVISED - J.A.F. 02-06
PLOT SCALE = 100,0000 ' / in.	DRAWN -	REVISED - S.P.B. 01-07
PLOT DATE = 7/7/2022	CHECKED -	REVISED - S.P.B. 12-09
	DATE -	REVISED - M.D.06-13

**STATE OF ILLINOIS  
DEPARTMENT OF TRANSPORTATION**

**FREEWAY /EXPRESSWAY SIGNING FOR FLAGGING OPERATIONS  
AT WORK ZONE OPENINGS ON FREEWAYS /EXPRESSWAYS**

SCALE: NONE SHEET 1 OF 1 SHEETS STA. TO STA.

F.A. RTE.	SECTION	COUNTY	TOTAL SHEETS	SHEET NO.
VAR	2022 GUARDRAIL 01	VARIOUS	32	32
<b>TC-18</b>			CONTRACT NO. 62T90	
ILLINOIS FED. AID PROJECT				