

**LONG. SECTION**

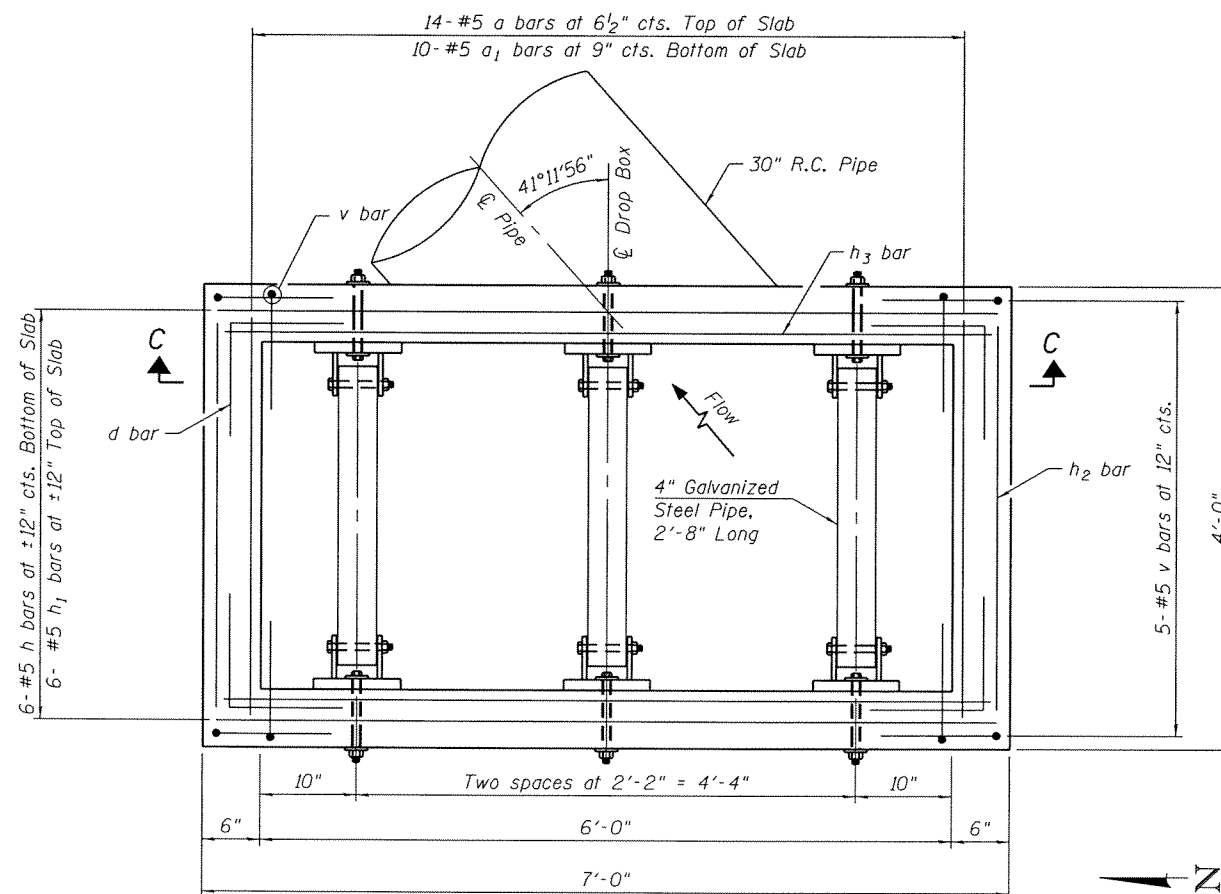

**PLAN**

**GENERAL NOTES:**

1. Reinforcement bars shall conform to the requirements of ASTM A 706 Gr 60.
2. All exposed concrete edges shall be chamfered  $\frac{3}{4}$ " unless otherwise noted.
3. All construction joints shall be bonded.
4. The contract unit price "Each" for Drop Box No. 4 shall include the Concrete Structures, Reinforcement Bars, earth excavation where required, backfilling and necessary grading to fit the structure as shown, or to the slope.
5. The contract unit price "Foot" for Traversable Pipe Grate shall include the steel pipe grate system, steel plates, bolts, nuts and washers.
6. Steel pipes shall conform to ASTM A-53 (Type E or S) Grade B, Schedule 40 and shall be galvanized conforming to ASTM A-120.
7. Steel plates shall conform to AASHTO M-183 and shall be galvanized conforming to AASHTO M-111.
8. Bolts, nuts and washer shall be in accordance with Article 1006.08 of the Standard Specifications and shall be galvanized.
9. Contractor shall field verify galvanized pipe length.
10. The minimum distance from the center of a hole to the free edge of a structural shape or plate shall be  $\frac{1}{2}$ " unless noted otherwise.
11. Bolts shall be snug tightened by a few impacts of an impact wrench or the full force of a worker using an ordinary spud wrench.
12. This work shall be done according to the application portions of 501, 503, 505, 508 and 540 of the Standard Specifications.
13. Fabrication of the Steel Pipe Grate System shall conform to the requirements in Section 505 of the Standard Specifications unless noted otherwise.
14. Contractor to confirm that a minimum allowable gross bearing pressure equal to 2000 PSF can be achieved prior to construction of Drop Box structure.
15. Backfilling and future excavations shall be performed equally on all sides of the structure.

**DESIGN STRESSES**

**FIELD UNITS**

$f'_c = 3,500$  psi  
 $f_y = 60,000$  psi (Reinforcement)

**BILL OF MATERIAL**

ITEM	UNIT	TOTAL
Drop Box No. 4	Each	1
Traversable Pipe Grate	Foot	8



*[Signature]* 2-4-14  
 EXP 11/2014

**PLAN & ELEVATION**  
**DROP BOX NO. 4**  
 IL. 84 STATION 10+28.00 LT

FILE NAME = S:\JULI\_0308-6399\6346\071\Microstation\CADD\_Sheets\64725\_Sheet\_07.dgn

**SA STRAND ASSOCIATES**  
 1170 SOUTH HOBOLT ROAD  
 JULIET, ILLINOIS 60431  
 (815) 744-4200  
 IDFFR NO. 184-001273

USER NAME jahnkp  
 DESIGNED - MJD  
 CHECKED - RRD  
 DRAWN - BJF  
 CHECKED - RRD  
 PLOT SCALE  
 PLOT DATE 2/4/2014

DESIGNED - MJD  
 CHECKED - RRD  
 DRAWN - BJF  
 CHECKED - RRD  
 REVISED  
 REVISED  
 REVISED  
 REVISED

REVISED  
 REVISED  
 REVISED  
 REVISED

**STATE OF ILLINOIS**  
**DEPARTMENT OF TRANSPORTATION**

**PLAN AND ELEVATION**  
**DROP BOX NO. 4**

SHEET NO. 57 OF 510 SHEETS

F.A.U. RTE.	SECTION	COUNTY	TOTAL SHEETS	SHEET NO.
5851	2R-1	HENRY	235	55

CONTRACT NO. 64743

ILLINOIS FED. AID PROJECT