

NOTE:  
 WHEN MILLING OPERATIONS PRODUCE A ROUNDED EDGE,  
 THEN A SAW CUT SHALL BE USED TO MANUFACTURE  
 A PERPENDICULAR EDGE AS SHOWN IN THE DETAIL.  
 THE ENGINEER SHALL BE THE SOLE JUDGE  
 CONCERNING THE USE OF THIS DETAIL

### HMA DETAIL AT BUTT JOINTS

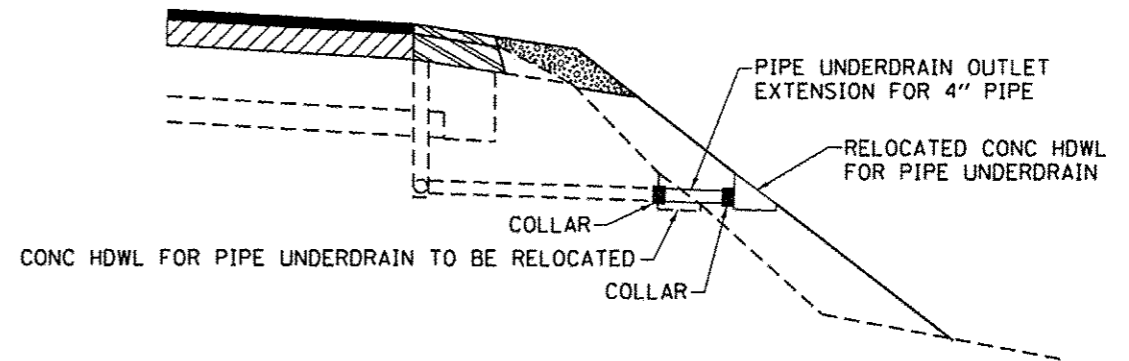

PIPE UNDERDRAIN TO BE FIELD LOCATED BY THE CONTRACTOR AND AS DIRECTED BY THE ENGINEER

### PIPE UNDERDRAIN OUTLET EXTENSION FOR 4" PIPE

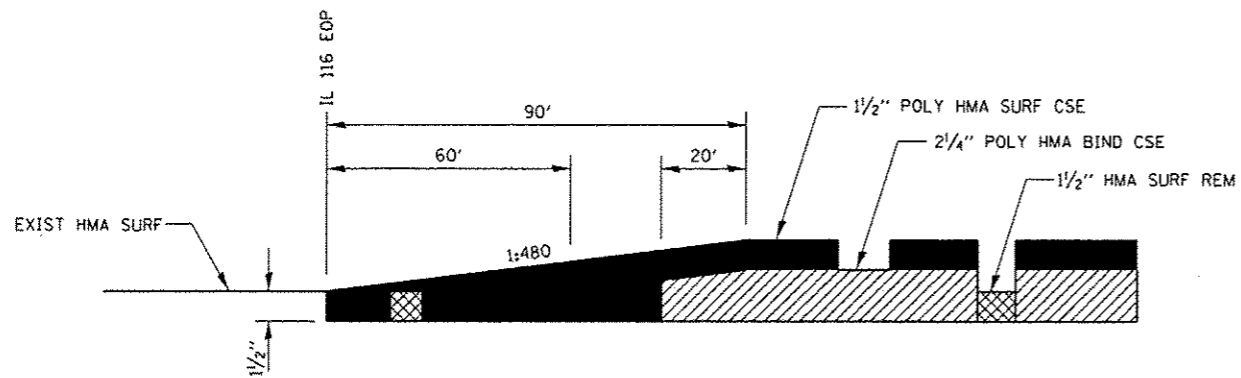

### TAPER AT RAMPS

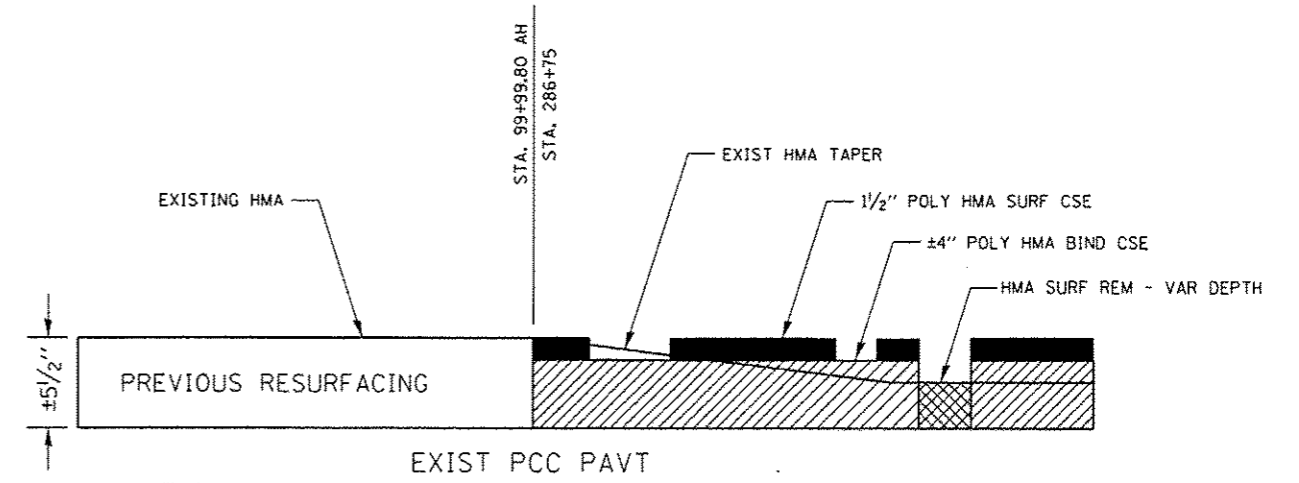

### BEGINNING & ENDING TAPERS

FILE NAME :	USER NAME :	DESIGNED :	REVISED :	<b>STATE OF ILLINOIS DEPARTMENT OF TRANSPORTATION</b>	<b>DETAILS</b>	F.A.I. RTE.	SECTION	COUNTY	TOTAL SHEETS	SHEET NO.	
er\pv_work\p\sidot\duncanbd\08315542\0366C53-shr-detaila.dgn		DRAWN :	REVISED :			57	(38-31RS-2	IROQUOIS	186	45	
		CHECKED :	REVISED :			CONTRACT NO. 66C53					
		DATE :	REVISED :			FED. ROAD DIST. NO. [ILLINOIS] FED. AID PROJECT					
				SCALE:	SHEET NO. OF SHEETS	STA. TO STA.					