

WING WALL ELEVATION
Showing Dimensions

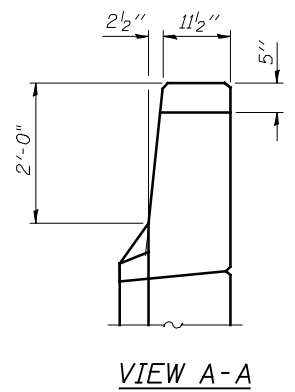

VIEW A-A

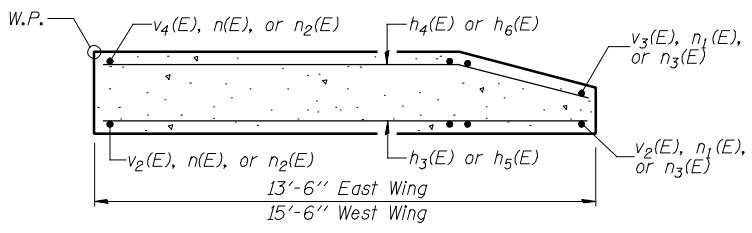

SECTION B-B

Notes:
 Hatched area to be poured after superstructure false work has been removed. Quantity of concrete included with Concrete Superstructure.
 Space reinforcement in cap to miss anchor bolts.
 Pour steps monolithically with cap.
 Quantity of concrete in end post included with Concrete Superstructure on sheet 19 of 62.
 For Concrete Encasement details, see sheet 53 of 62.

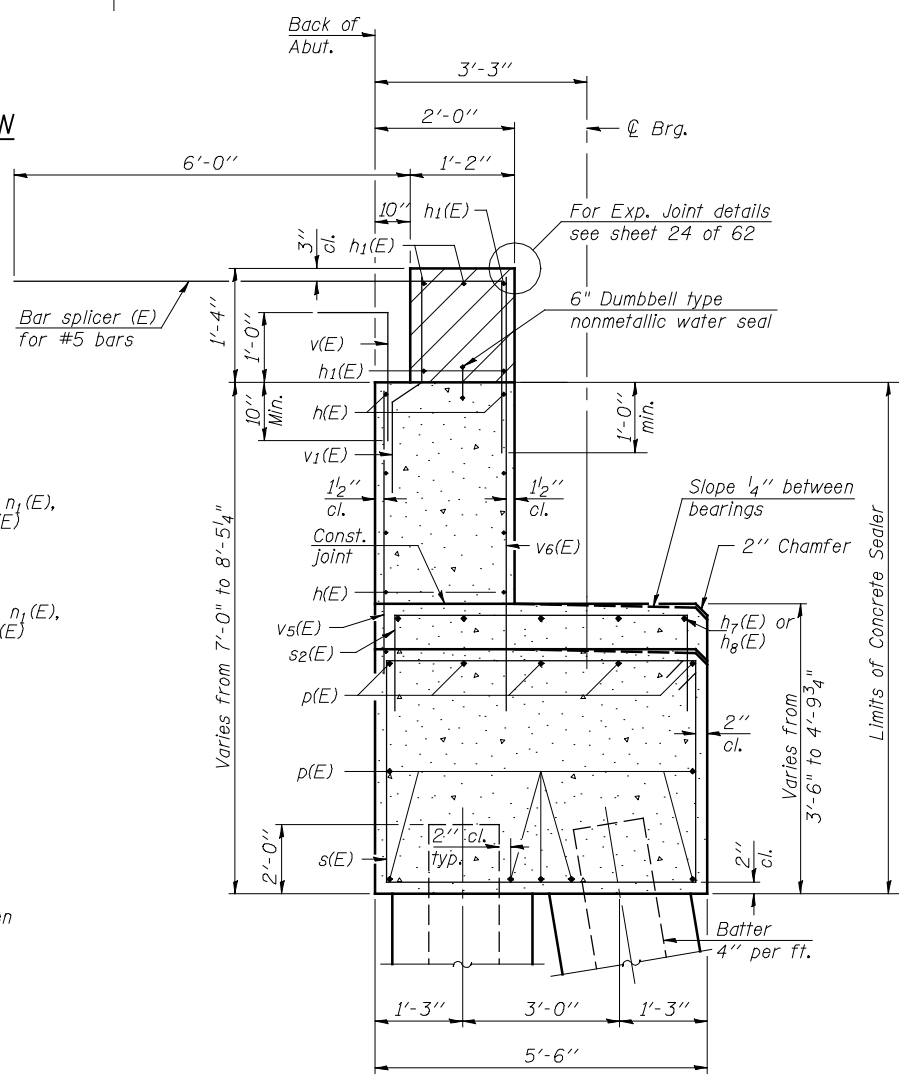

SEC. THRU ABUT.

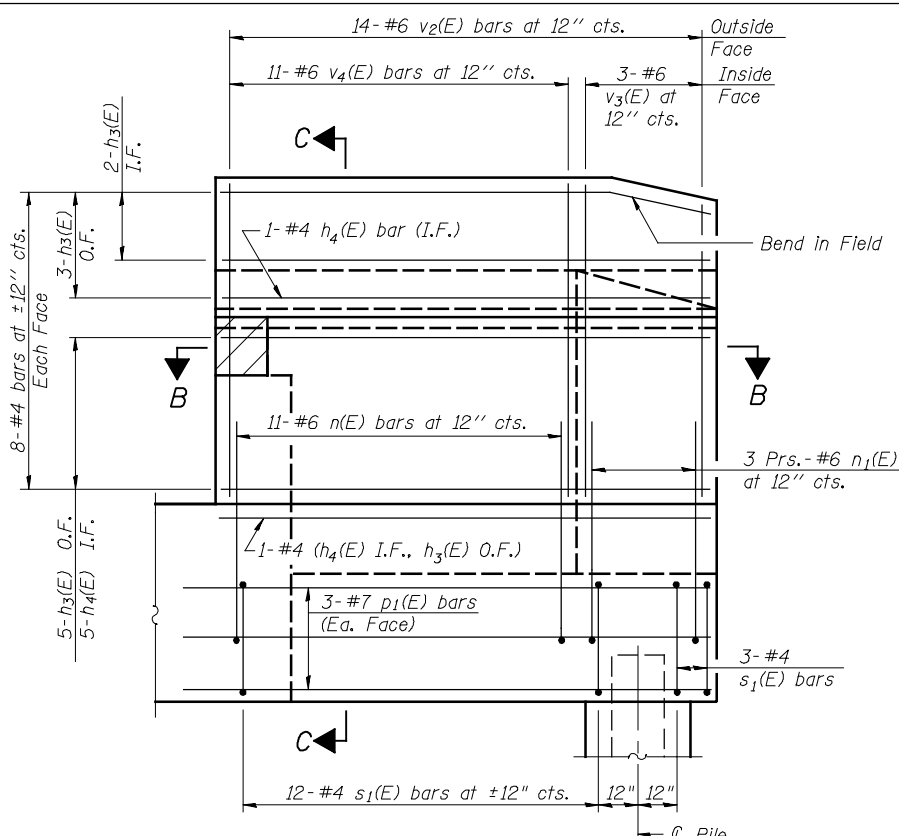

EAST WING WALL ELEVATION
Showing Reinforcement

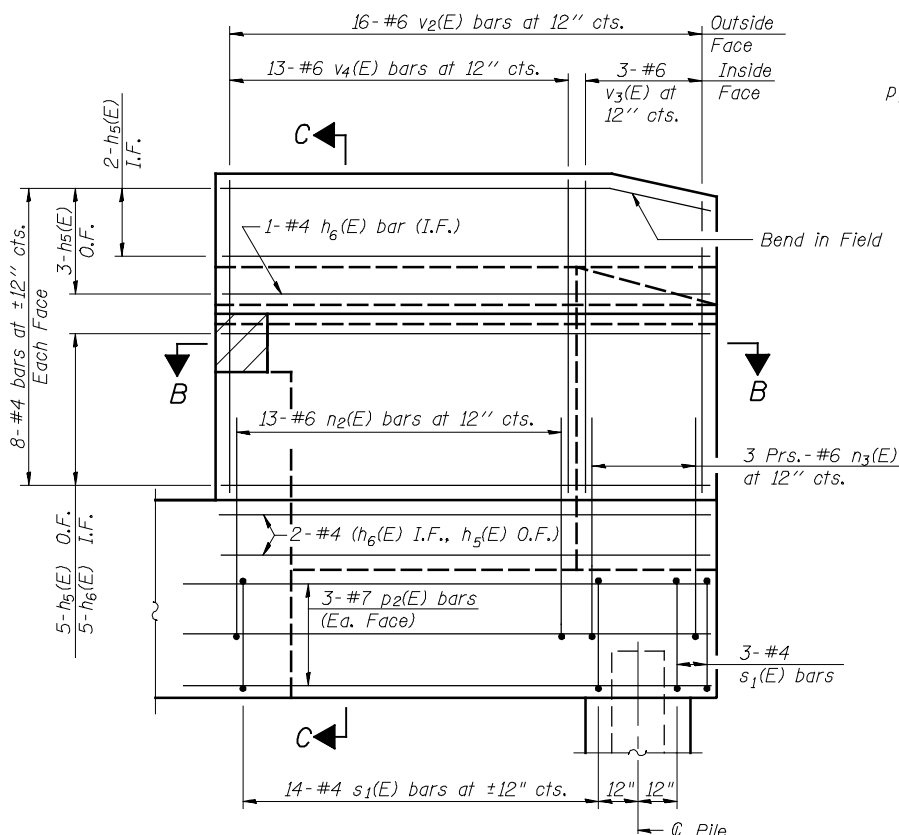

WEST WING WALL ELEVATION
Showing Reinforcement

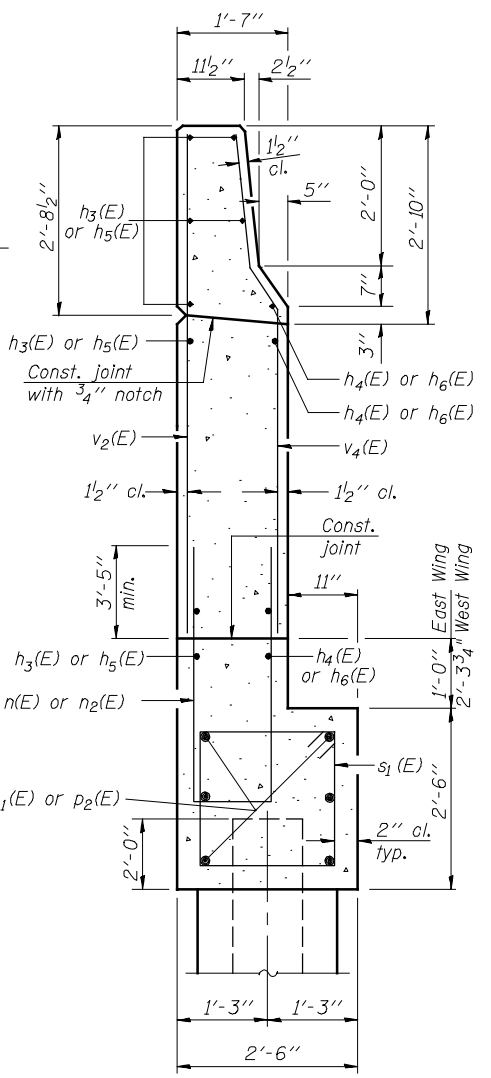

SECTION C-C

Hutchison Engineering, Inc.
 Jacksonville, Peoria, & Shorewood, Illinois

USER NAME = jdean	DESIGNED - JOH	REVISD -
PLOT SCALE = NONE	CHECKED - BAN	REVISD -
PLOT DATE = 7/25/2013	DRAWN - TAC	REVISD -
	CHECKED - JOH/BAN	REVISD -

STATE OF ILLINOIS
DEPARTMENT OF TRANSPORTATION

NORTH ABUTMENT DETAILS
STRUCTURE NO. 062-0086

F.A.P. RTE. 698	SECTION (125VBR)BR	COUNTY MARSHALL	TOTAL SHEETS 148	SHEET NO. 63
			CONTRACT NO. 68580	
ILLINOIS FED. AID PROJECT				