

EAST EDGE OF SLAB

Location	Station	Offset	Theoretical Grade Elevations	Theoretical Grade Elevations Adjusted For Grinding
End N. Appr. Slab	196+96.25	-23.00	761.64	761.66
H	197+06.25	-23.00	761.78	761.80
I	197+16.25	-23.00	761.89	761.92
N. End Bridge Deck	197+26.25	-23.00	761.99	762.02

EAST EDGE OF PAVEMENT

Location	Station	Offset	Theoretical Grade Elevations	Theoretical Grade Elevations Adjusted For Grinding
End N. Appr. Slab	196+95.36	-18.00	761.47	761.49
H	197+05.36	-18.00	761.61	761.63
I	197+15.36	-18.00	761.73	761.75
N. End Bridge Deck	197+25.36	-18.00	761.84	761.86

☉ F.A.P. 730 & P.G.L.

Location	Station	Offset	Theoretical Grade Elevations	Theoretical Grade Elevations Adjusted For Grinding
End N. Appr. Slab	196+92.19	0.00	761.70	761.72
H	197+02.19	0.00	761.84	761.86
I	197+12.19	0.00	761.97	761.99
N. End Bridge Deck	197+22.19	0.00	762.08	762.10

STAGE CONSTRUCTION LINE

Location	Station	Offset	Theoretical Grade Elevations	Theoretical Grade Elevations Adjusted For Grinding
End N. Appr. Slab	196+91.93	1.50	761.67	761.69
H	197+01.93	1.50	761.81	761.84
I	197+11.93	1.50	761.94	761.96
N. End Bridge Deck	197+21.93	1.50	762.05	762.07

WEST EDGE OF PAVEMENT

Location	Station	Offset	Theoretical Grade Elevations	Theoretical Grade Elevations Adjusted For Grinding
End N. Appr. Slab	196+89.37	16.00	761.41	761.43
H	196+99.37	16.00	761.56	761.58
I	197+09.37	16.00	761.69	761.71
N. End Bridge Deck	197+19.37	16.00	761.81	761.83

WEST EDGE OF SLAB

Location	Station	Offset	Theoretical Grade Elevations	Theoretical Grade Elevations Adjusted For Grinding
End N. Appr. Slab	196+88.49	21.00	761.55	761.57
H	196+98.49	21.00	761.70	761.72
I	197+08.49	21.00	761.83	761.85
N. End Bridge Deck	197+18.49	21.00	761.95	761.97

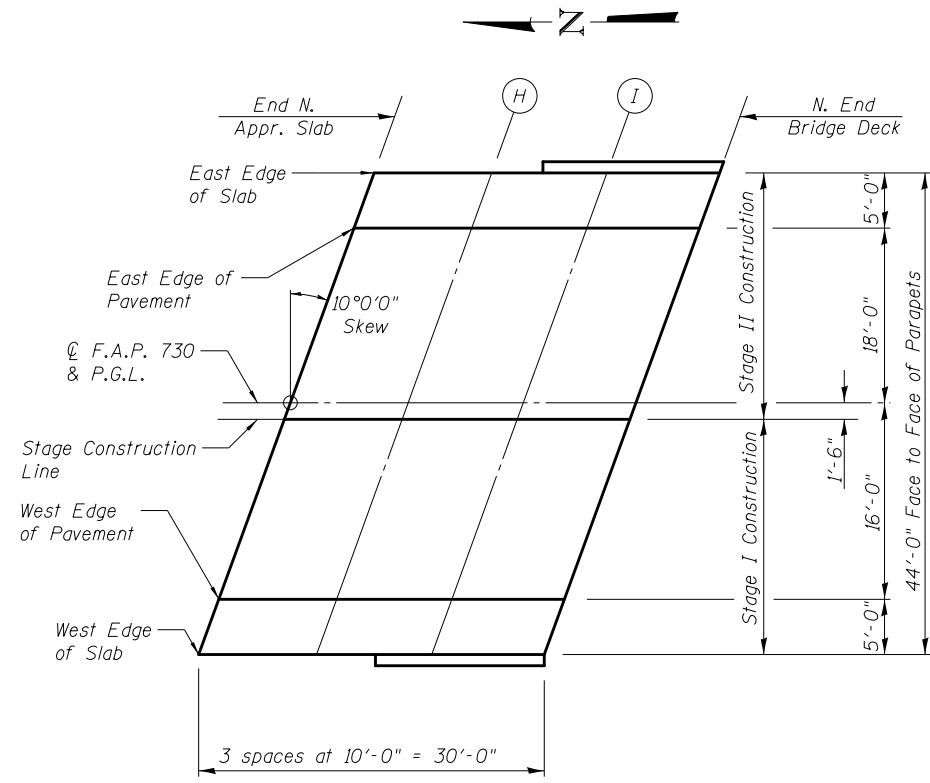

PLAN