

Notes:

The existing expansion joints at the abutments of each of the following structures shall be replaced according to the details indicated herein:

- SN 084-0140
- SN 084-0141
- SN 084-0143
- SN 084-0144
- SN 084-0145
- SN 084-0146

Except for SN 084-0141, the existing backer rod and silicone joint sealer shall be removed. At SN 084-0141, the existing preformed joint seal shall be removed. Removal of the existing backer rod, joint sealer, and preformed joint seal will not be measured for payment but shall be included in the cost of Silicone Joint Sealer, of the size specified.

Joint replacement for each of the structures shall be completed using daytime lane closures in accordance with Highway Standard 701201.

See sheets 2 through 13 for existing structure information.

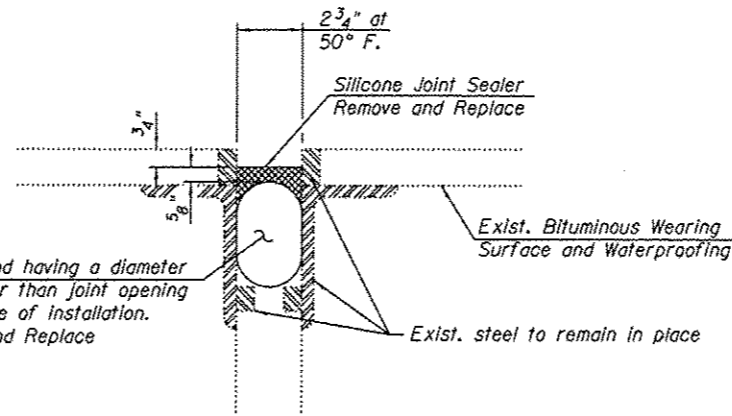

SECTION THRU EXPANSION JOINT
(Typ. for SN 084-0140, SN 084-0141 similar.)

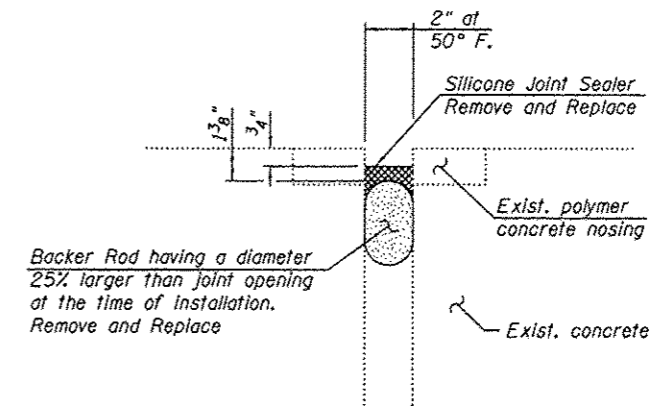

SECTION THRU EXPANSION JOINT
(Typ. for SN 084-0143, 0144, 0145, and 0146)

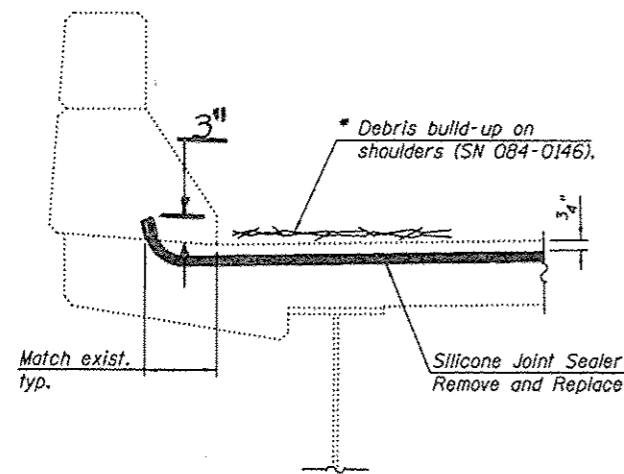

TYPICAL END OF SEAL TREATMENT

BILL OF MATERIAL

(SN 084-0140)

Item	Unit	Total
Silicone Joint Sealer, 2 3/4"	Foot	60

BILL OF MATERIAL

(SN 084-0141)

Item	Unit	Total
Silicone Joint Sealer, 2 3/4"	Foot	62

BILL OF MATERIAL

(SN 084-0143)

Item	Unit	Total
Silicone Joint Sealer, 2"	Foot	59

BILL OF MATERIAL

(SN 084-0144)

Item	Unit	Total
Silicone Joint Sealer, 2"	Foot	55

BILL OF MATERIAL

(SN 084-0145)

Item	Unit	Total
Silicone Joint Sealer, 2"	Foot	61

*** BILL OF MATERIAL**

(SN 084-0146)

Item	Unit	Total
Silicone Joint Sealer, 2"	Foot	55

* Debris build-up on structure shoulders shall be completely removed and disposed of according to the Standard Specifications. The cost of removing and disposing of debris shall be considered in the Contract Unit prices and no additional compensation will be made.

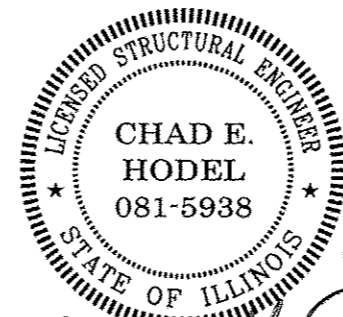

Handwritten signature and date: 8-21-14

Expires: 11/30/2014