

**FIELD ENTRANCE DETAIL**

ALLOWABLE FIELD ENTRANCE WIDTHS (W):  
20' MINIMUM, 30' MAXIMUM.

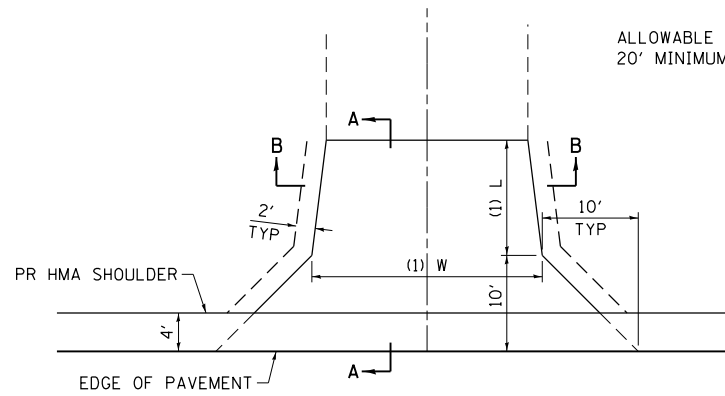

**PLAN**

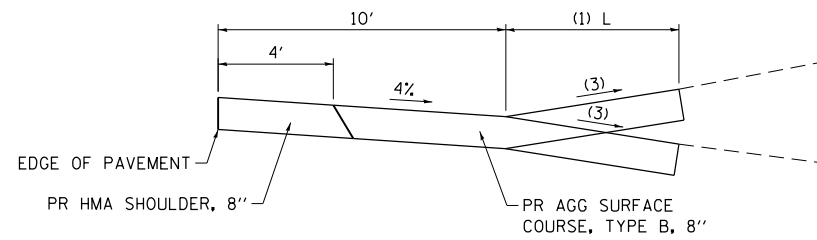

**SECTION A-A**  
(NOT TO SCALE)

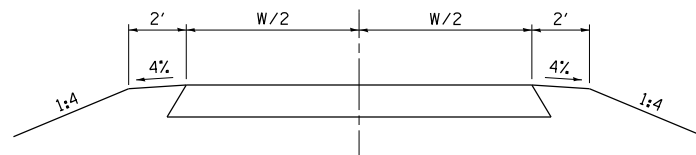

**SECTION B-B**  
(NOT TO SCALE)

**AGGREGATE PRIVATE/COMMERCIAL ENTRANCE DETAIL**

ALLOWABLE PRIVATE ENTRANCE WIDTHS (W):  
12' MINIMUM, 24' MAXIMUM.  
ALLOWABLE COMMERCIAL ENTRANCE WIDTHS (W):  
14' MINIMUM, 24' MAXIMUM - 1 WAY  
24' MINIMUM, 35' MAXIMUM - 2 WAY

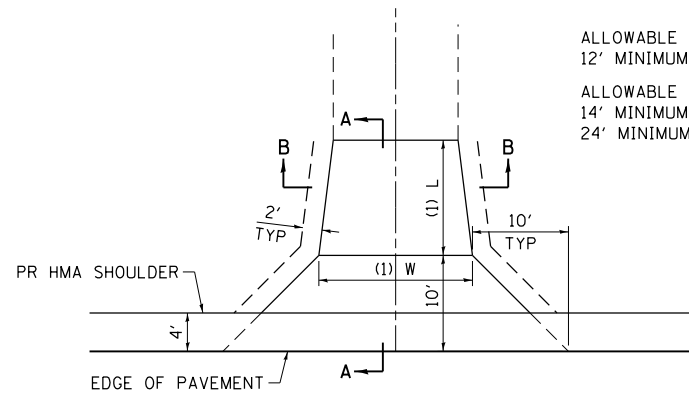

**PLAN**

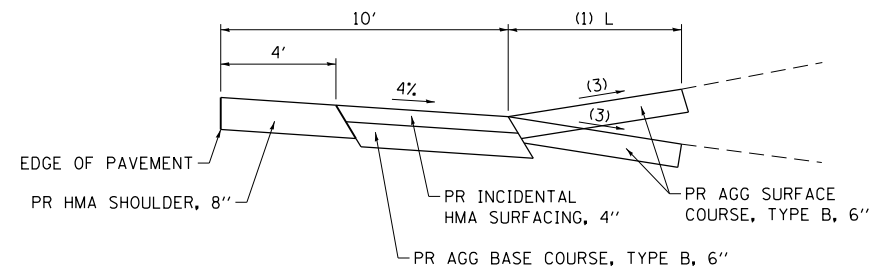

**SECTION A-A PRIVATE ENTRANCE**  
(NOT TO SCALE)

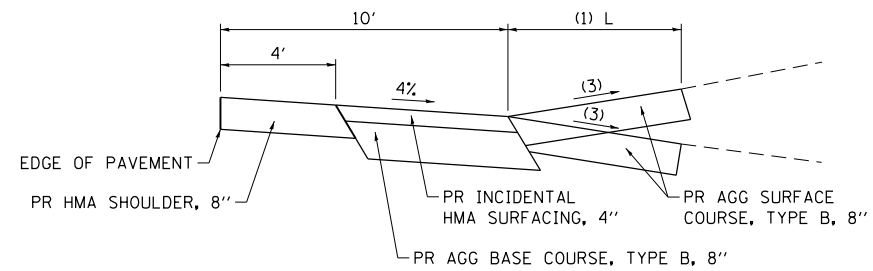

**SECTION A-A COMMERCIAL ENTRANCE**  
(NOT TO SCALE)

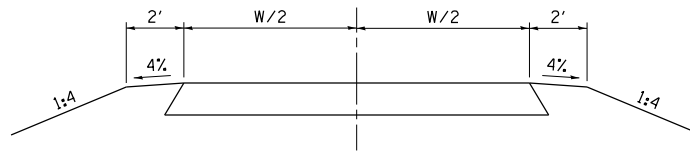

**SECTION B-B**  
(NOT TO SCALE)

**AGGREGATE PRIVATE ENTRANCE DETAIL OFF SIDE ROADS**

ALLOWABLE PRIVATE ENTRANCE WIDTHS (W):  
12' MINIMUM, 24' MAXIMUM.

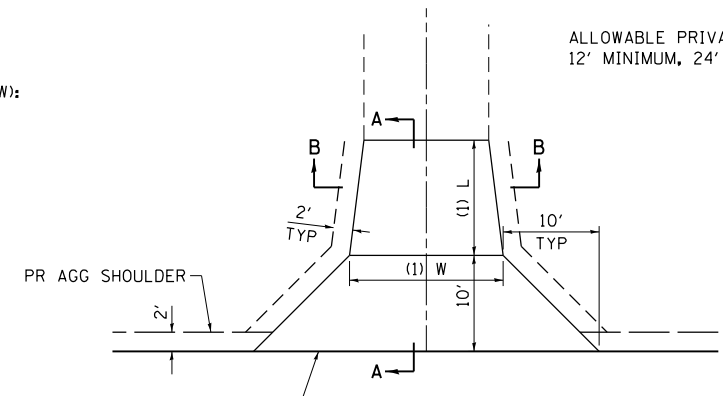

**PLAN**

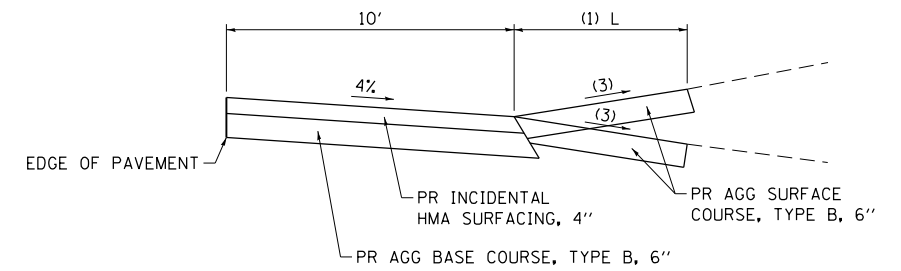

**SECTION A-A PRIVATE ENTRANCE**  
(NOT TO SCALE)

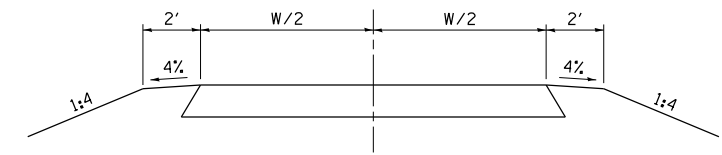

**SECTION B-B**  
(NOT TO SCALE)

**NOTES:**

- (1) SEE ENTRANCE SCHEDULE FOR W AND L DIMENSIONS
- (2) RADIUS VARIES SEE PLAN & PROFILE SHEETS
- (3) SEE CROSS SECTIONS FOR SLOPE

FILE NAME = S:\Projects\085-022B-VHY\_IL\_3\_Greentown\dm\CADD\_Sheets\085022B-VHY-INT-DETAILS.dgn



USER NAME = l_jackson	DESIGNED - ACM	REVISED -
MODEL NAME = DETAIL 1	DRAWN - EDW	REVISED -
PLOT SCALE = 20.0000' / in.	CHECKED - LWJ	REVISED -
PLOT DATE = 8/11/2014	DATE - 8-11-14	REVISED -

**STATE OF ILLINOIS  
DEPARTMENT OF TRANSPORTATION**

**AGGREGATE & FIELD ENTRANCE  
DETAILS**

SCALE: SHEET 1 OF 9 SHEETS

F.A.S. RTE.	SECTION	COUNTY	TOTAL SHEETS	SHEET NO.
•	101-2RS-1	JERSEY	438	285
• 749/752		<b>CONTRACT NO. 76789</b>		
ILLINOIS FED. AID PROJECT				