

TYPICAL SECTION (IL 127)

M.P. 0.000 TO M.P. 0.136
M.P. 0.164 TO M.P. 0.365
M.P. 1.603 TO M.P. 1.792
M.P. 1.835 TO M.P. 2.098

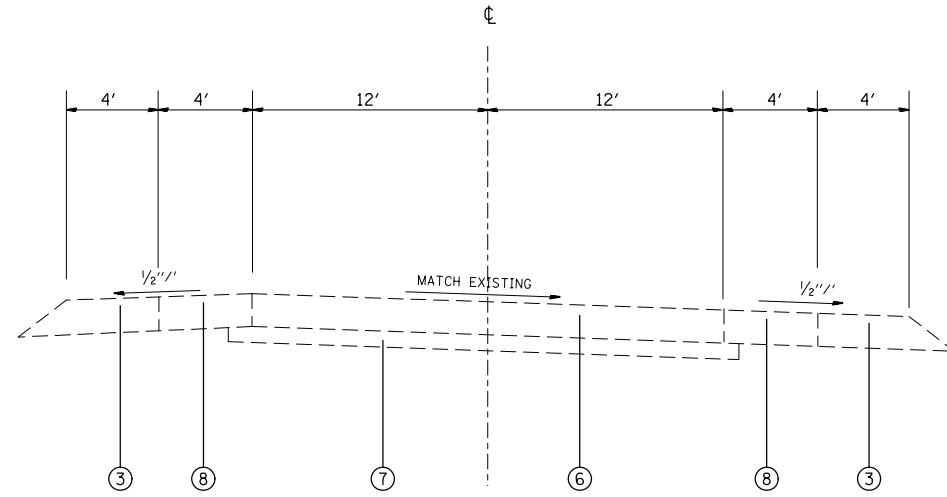

TYPICAL SECTION (IL 127)

M.P. 2.476 TO M.P. 2.621
M.P. 3.245 TO M.P. 3.380

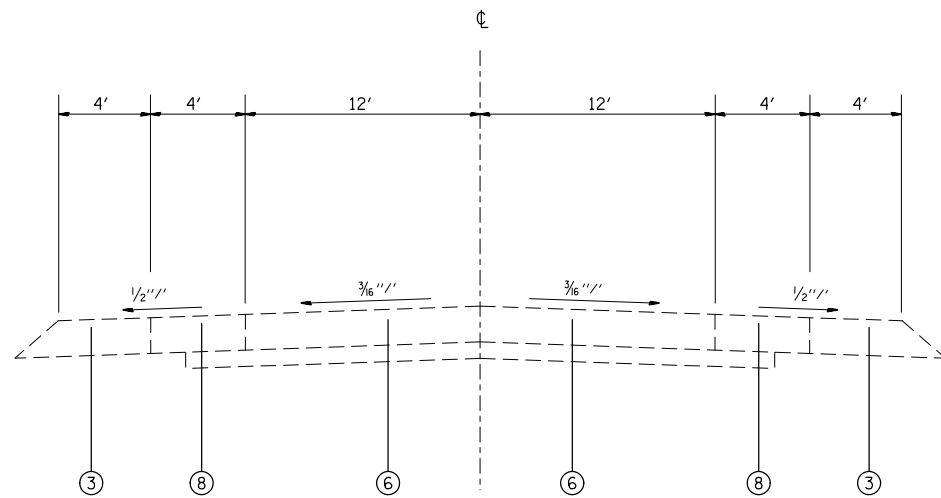

TYPICAL SECTION (IL 127)

M.P. 2.422 TO M.P. 2.476
M.P. 2.621 TO M.P. 3.245
M.P. 3.380 TO M.P. 3.403

LEGEND

- ① EXISTING PCC 9"-6"-9"
- ② EXISTING BASE COURSE WIDENING 8"
- ③ EXISTING AGGREGATE SHOULDER
- ④ EXISTING 3/4" DIAMETER BAR
- ⑤ EXISTING METAL JOINT
- ⑥ EXISTING PCC PAVEMENT 8"
- ⑦ EXISTING STABILIZED SUB-BASE 4"
- ⑧ EXISTING HMA SHOULDERS 8"

FILE NAME =	USER NAME = grandberryha	DESIGNED -	REVISED -
et:\pw\work\p\dot\grandberryha\d0396068	d876h34-sht-plan.dgn	DRAWN -	REVISED -
	PLOT SCALE = 100.0000' / 1in.	CHECKED -	REVISED -
	PLOT DATE = 7/23/2014	DATE -	REVISED -

**STATE OF ILLINOIS
DEPARTMENT OF TRANSPORTATION**

TYPICAL SECTIONS

SCALE: SHEET NO. OF SHEETS STA. TO STA.

F.A.P. RTE.	SECTION	COUNTY	TOTAL SHEETS	SHEET NO.
42	(111,112)-I	BOND&CLINTON	7	5
CONTRACT NO. 76H34				
FED. ROAD DIST. NO. 8 ILLINOIS FED. AID PROJECT				