

EXISTING TYPICAL CROSS SECTION

E. Harrison Ave.
6+00.00 TO 13+40.12
15+80.61 TO 30+43.00

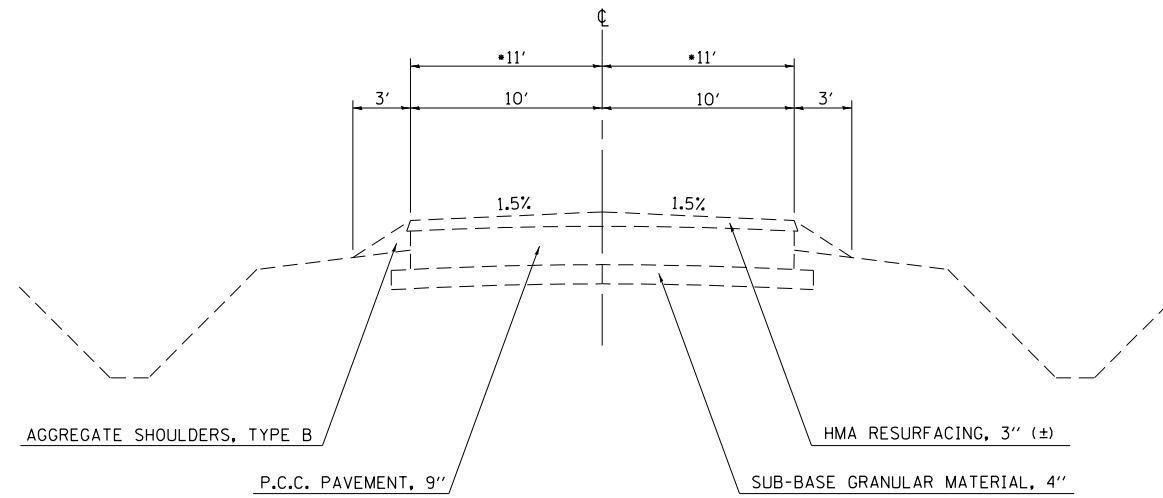

NOTE: NOT DRAWN TO SCALE

EXISTING TYPICAL CROSS SECTION

E. Harrison Ave. at IL 16
13+40.12 TO 14+45.66
14+72.86 TO 15+80.61

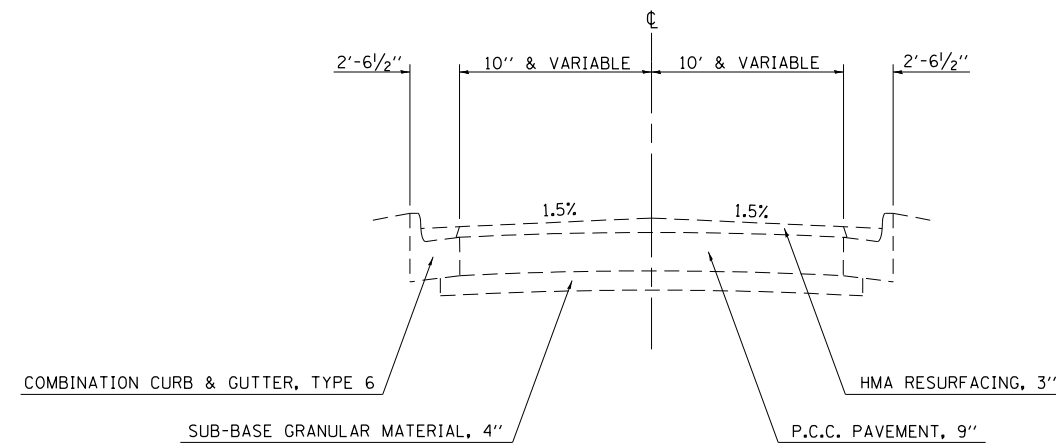

NOTE: NOT DRAWN TO SCALE

FILE NAME =	USER NAME = steffenmk	DESIGNED -	REVISED -	STATE OF ILLINOIS DEPARTMENT OF TRANSPORTATION	EXISTING TYPICAL CROSS SECTIONS			F.A.P. RTE.	SECTION	COUNTY	TOTAL SHEETS	SHEET NO.
ci:\pw\work\p\idot\steffenmk\d0158776\074423-sh-typical.dgn		DRAWN -	REVISED -		91	5N	Coles	271	11			
PLOT SCALE = 100.0000' / in.		CHECKED -	REVISED -		SCALE: NA SHEET 2 OF 10 SHEETS STA. TO STA.			CONTRACT NO. 74423				
PLOT DATE = 5/7/2014		DATE -	REVISED -		ILLINOIS FED. AID PROJECT							