

| | | | | |
|---------------------|------------|---------------------------|--------------|-----------|
| F.A.I. RTE. | SECTION | COUNTY | TOTAL SHEETS | SHEET NO. |
| 80/94 | 2626.2-R-2 | COOK/LAKE | 1207 | 315 |
| STA. | | TO STA. | | |
| FED. ROAD DIST. NO. | | ILLINOIS FED. AID PROJECT | | |
| CONTRACT NO. 62114 | | INDOT DES. NO. 0100987 | | |

GENERAL NOTES

- ① For eccentric and concentric cone heights see cone heights table on Standard Drawing 720-MHST-08.

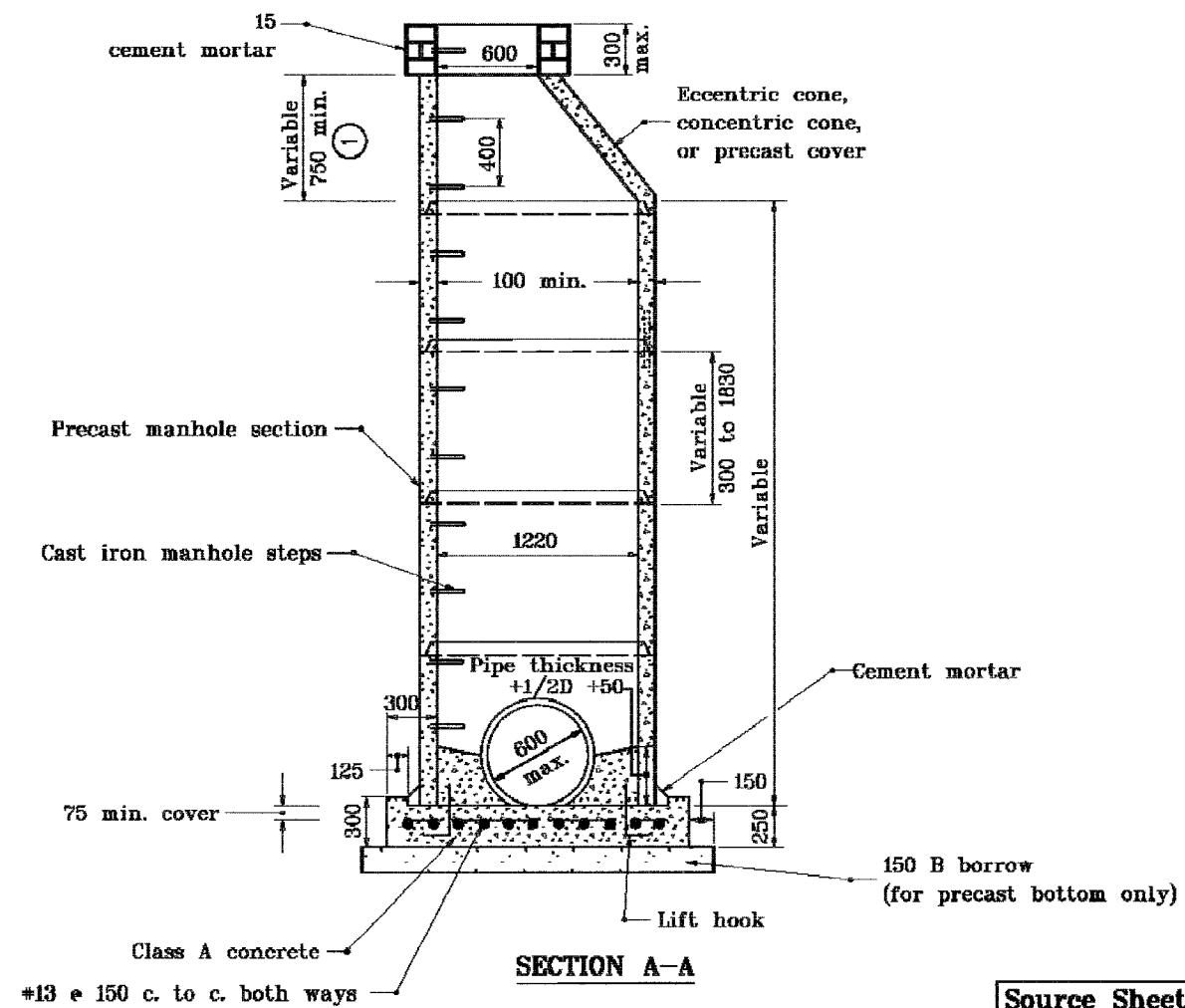
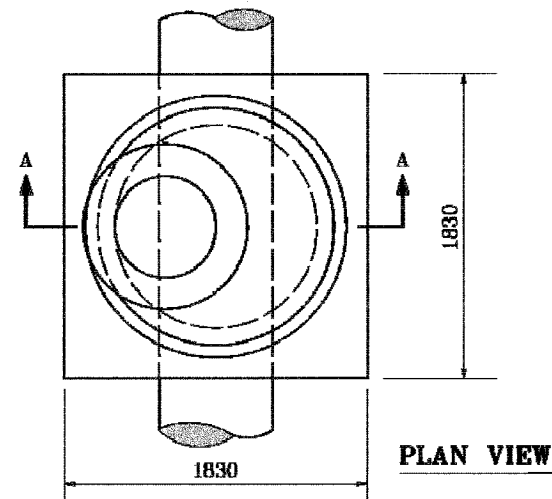

All dimensions are in mm unless otherwise specified.

| | |
|--------------------------------------|--|
| INDIANA DEPARTMENT OF TRANSPORTATION | |
| MANHOLE TYPE C | |
| SEPTEMBER 1997 | |
| STANDARD DRAWING NO. 720-MHST-02 | |
| | /s/ Anthony L. Uremovich 9-01-97 DESIGN STANDARDS ENGINEER DATE |
| | /s/ Donald W. Lucas 9-01-97 CHIEF HIGHWAY ENGINEER DATE |

Source Sheet: MD3