

F.A.I. RTE.	SECTION	COUNTY	TOTAL SHEETS	SHEET NO.
80/94	2626.2-R-2	COOK/LAKE	1207	534A
STA.	TO STA.			
FED. ROAD DIST. NO.	ILLINOIS FED. AID PROJECT			
CONTRACT NO. 62114	INDOT DES. NO. 0100987			

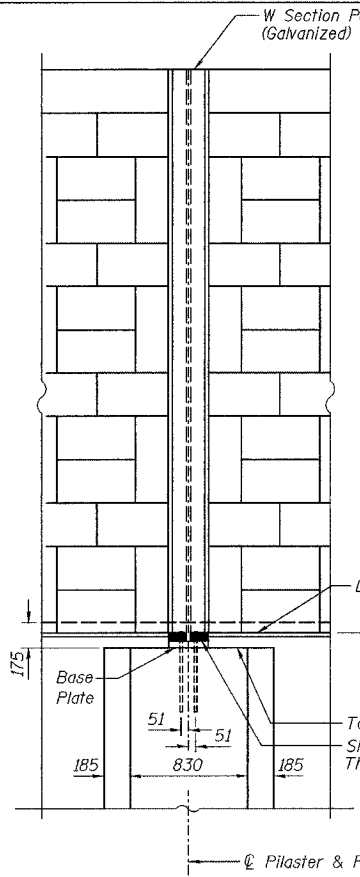

ALTERNATE STEEL POST (NO STEP)
(Looking @ Residential Side)

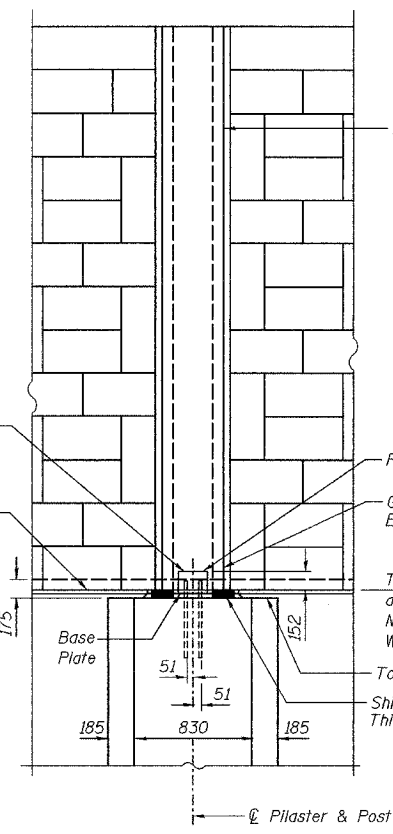

PRECAST POST (NO STEP)
(Looking @ Residential Side)

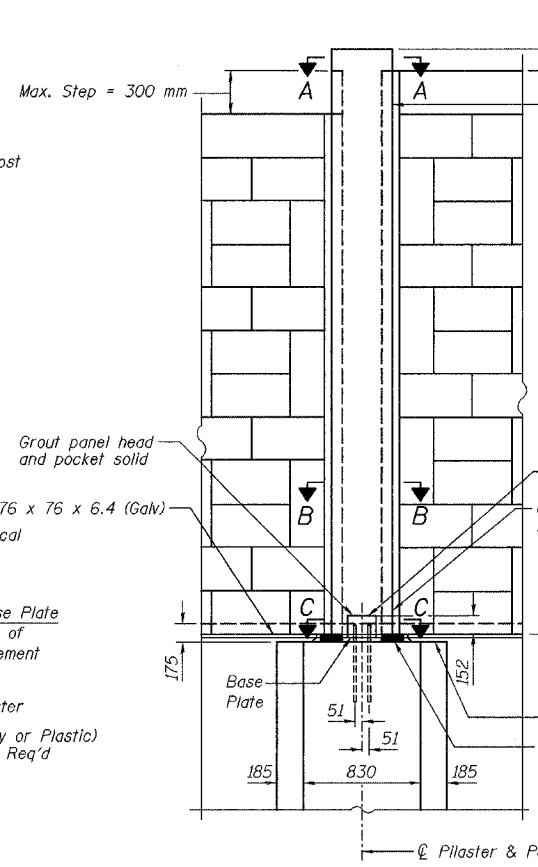

PRECAST POST AT NOISEWALL STEP
(Looking @ Residential side)

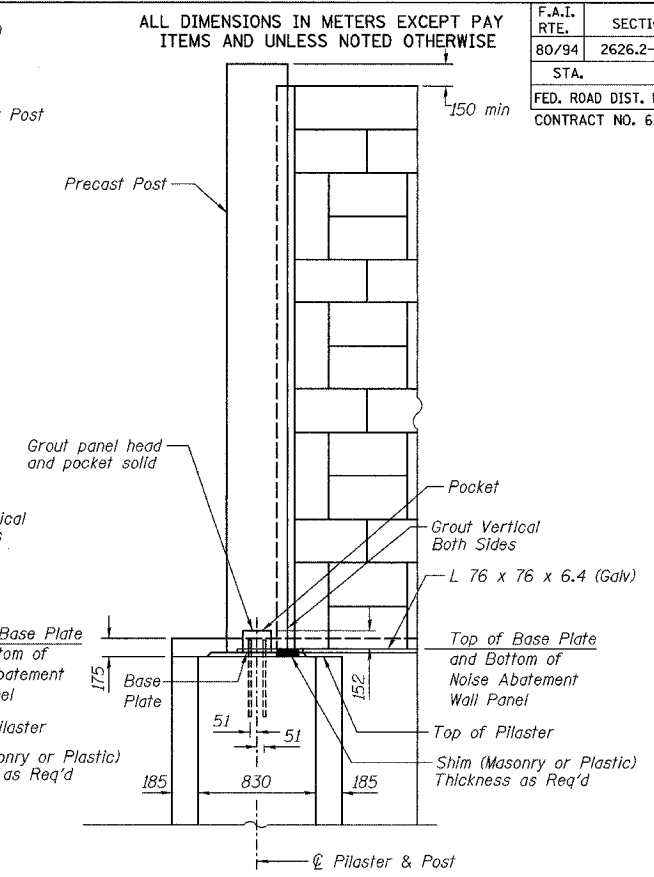

PRECAST POST AT NOISEWALL END
(Looking @ Residential side)

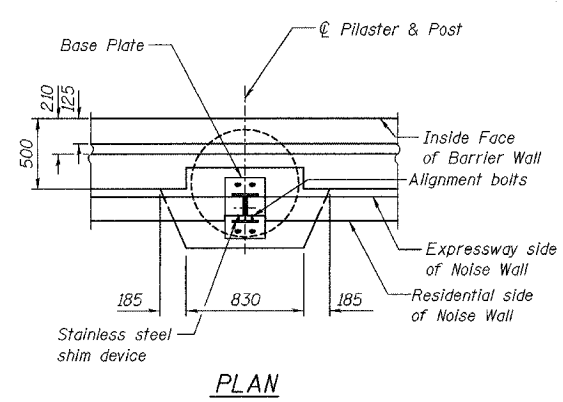

PLAN

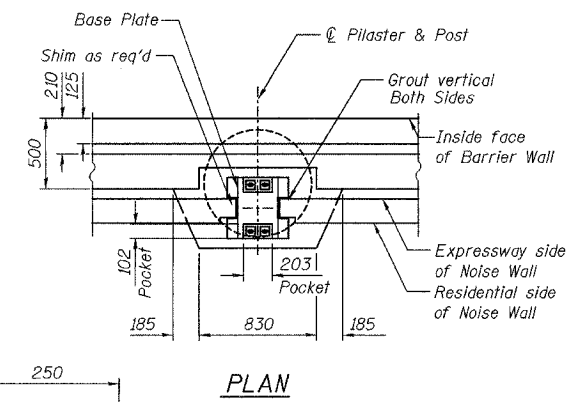

PLAN

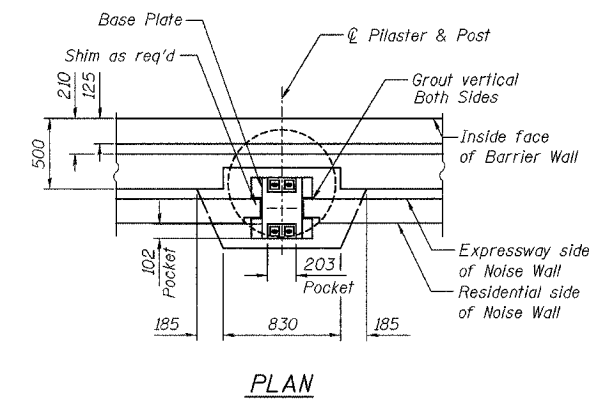

PLAN

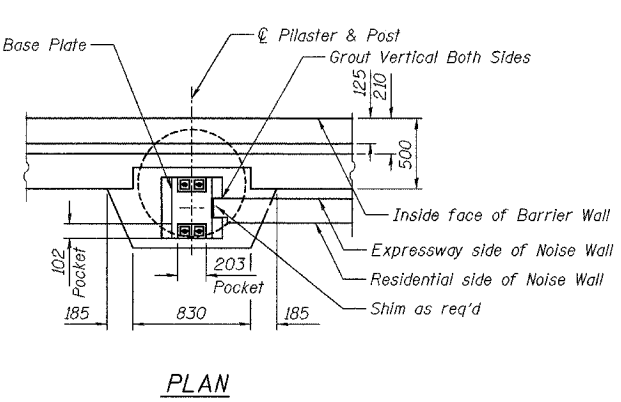

PLAN

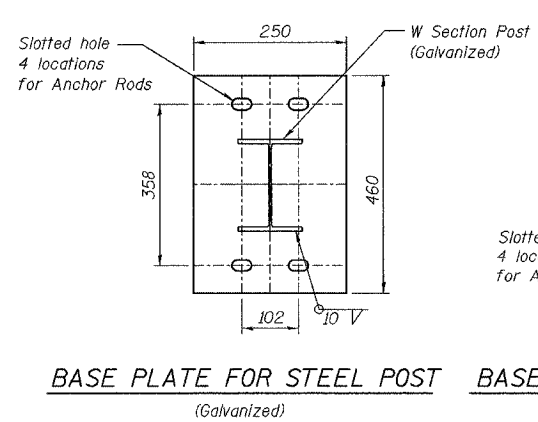

BASE PLATE FOR STEEL POST
(Galvanized)

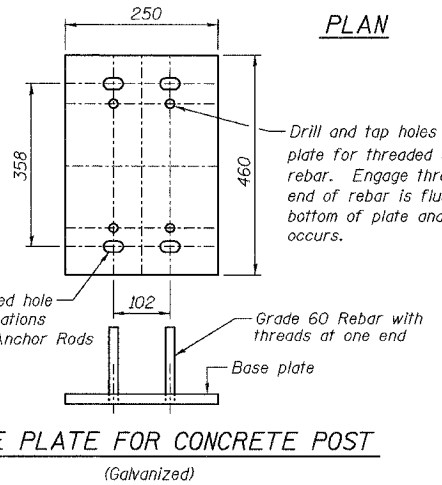

BASE PLATE FOR CONCRETE POST
(Galvanized)

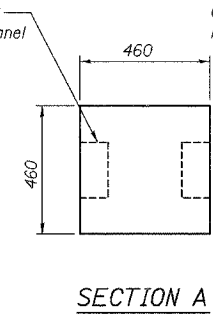

SECTION A

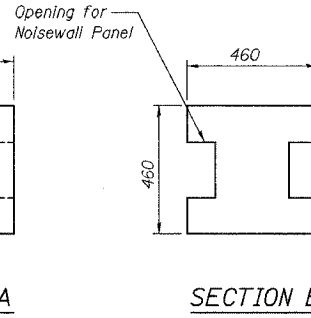

SECTION B

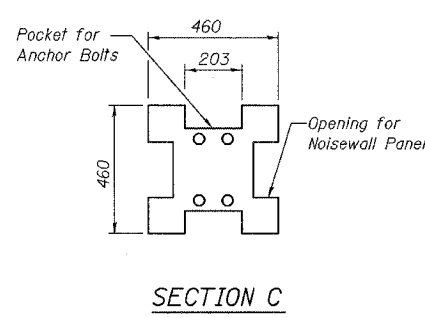

SECTION C

Notes:
Size of slotted holes, base plate thickness and threaded rebar dimensions to be determined by manufacturer.

REVISIONS	
NAME	DATE

ILLINOIS DEPARTMENT OF TRANSPORTATION
I-80/94/US 6
KINGERY-BORMAN EXPRESSWAY
BURNHAM ROAD TO US 41
**NOISE ABATEMENT WALL
STRUCTURE MOUNTED**

SCALE: DATE 07/05
DRAWN BY ACE/CAD
CHECKED BY TAE

AMERICAN
CONSULTING ENGINEERS