

ELEVATION AT ABUT.

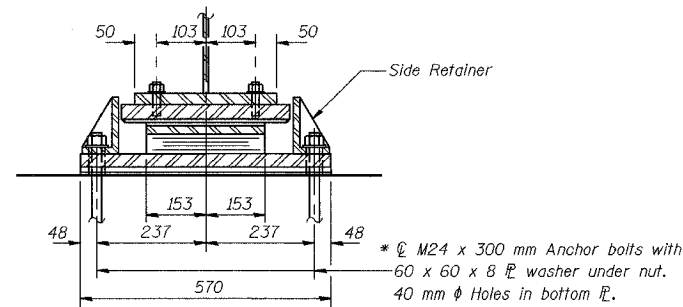

SECTION A-A

TYPE II ELASTOMERIC EXP. BRG. AT EAST ABUTMENT

Notes: See Sheet S-47 for Anchor Bolt installation. All dimensions are in millimeters (mm) except as noted.

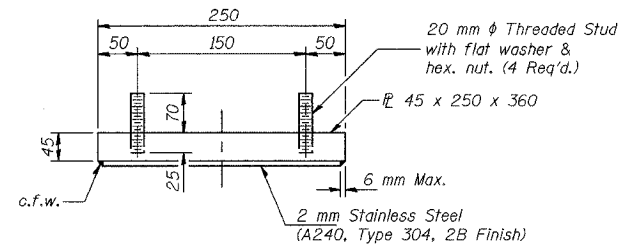

TOP BEARING ASSEMBLY

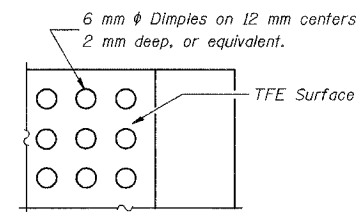

PLAN-TFE SURFACE

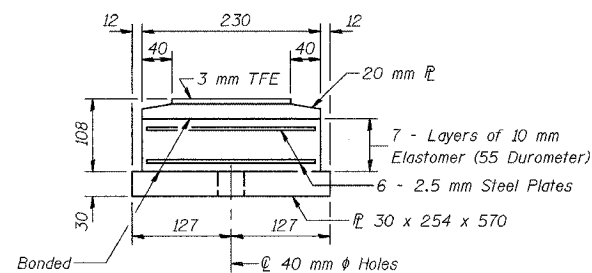

BOTTOM BEARING ASSEMBLY

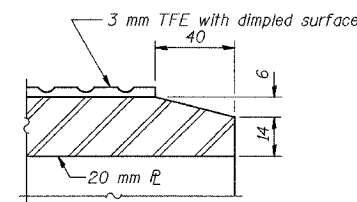

SECTION THRU TFE

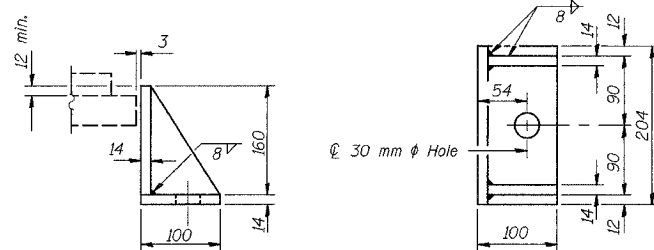

SIDE RETAINER

Equivalent rolled angle with stiffeners will be allowed in lieu of welded plates. Mass included with Structural Steel.

Note: The 3 mm TFE sheet shall be bonded directly to the top steel plate with a two-component, medium viscosity epoxy resin, conforming to the requirements of the Federal Specification MMM-A-154, Type I. The bond agent shall be applied on the full area of the contact surfaces.

Bonding of 3 mm TFE sheet during vulcanizing process will be permitted provided the process and method of adjusting assembly height is approved by the Engineer.

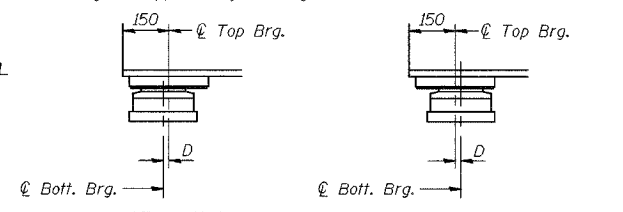

BELOW 10 °C (Move bott. brg. away from fixed brg.) ABOVE 10 °C (Move bott. brg. toward fixed brg.)

SETTING ANCHOR BOLTS AT EXP. BRG.

D = 1 mm per each 10 m of expansion for every 8 °C temp. change from the normal temp. of 10 °C.

DESIGNED	BHS
CHECKED	KFA
DRAWN	MJB
CHECKED	GSP

BILL OF MATERIAL

Item	Unit	Total
* Furnishing Elastomeric Bearing Assembly, Type II	Each	28

ILLINOIS DEPARTMENT OF TRANSPORTATION
F.A.I. ROUTE 80/94 (BORMAN EXPRESSWAY)
OVER LITTLE CALUMET RIVER & N.I.C.T.D. R.O.W.

BEARING DETAILS (5 OF 5)
SECTION 2626.2-R-1
LAKE COUNTY, INDIANA
STATION 8+470.000

STRUCTURE NO. I-80-1-8460 (EB & WB)
DATE 07/05 (016-1003 & 016-1004)

AMERICAN
CONSULTING ENGINEERS

*** FURNISHING BEARINGS NOT INCLUDED IN THIS CONTRACT**