

SHOULDER WIDENING AT MAINTENANCE CROSSOVERS

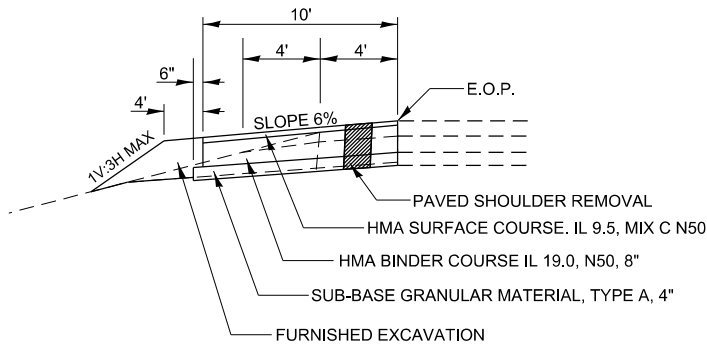

NOTES

- 1.) OMIT RUMBLE STRIPS ON SHOULDERS WITHIN THESE LIMITS.
- 2.) REMOVAL OF EXISTING AGGREGATE SHOULDERS IS INCIDENTAL TO THE COST OF THE PROPOSED 8" HMA BINDER COURSE.

SECTION B-B