

NOTES:

RUMBLE STRIPS SHALL NOT BE PLACED ON BRIDGES.

ALL RUMBLE STRIPS SHALL BE MILLED.

CENTERLINE RUMBLE STRIPS SHALL BE CONTINUOUS THROUGH INTERSECTIONS WITH NO MAJOR ROUTE LEFT TURN LANES.

DISCONTINUE CENTERLINE RUMBLE STRIPS THROUGH THE TAPER AND STORAGE LIMITS OF ALL LEFT TURN LANES.

WHERE USED, ADJUST SPACING OF RAISED REFLECTIVE PAVEMENT MARKERS TO FALL IN WIDER GAP BETWEEN RUMBLE STRIPS.

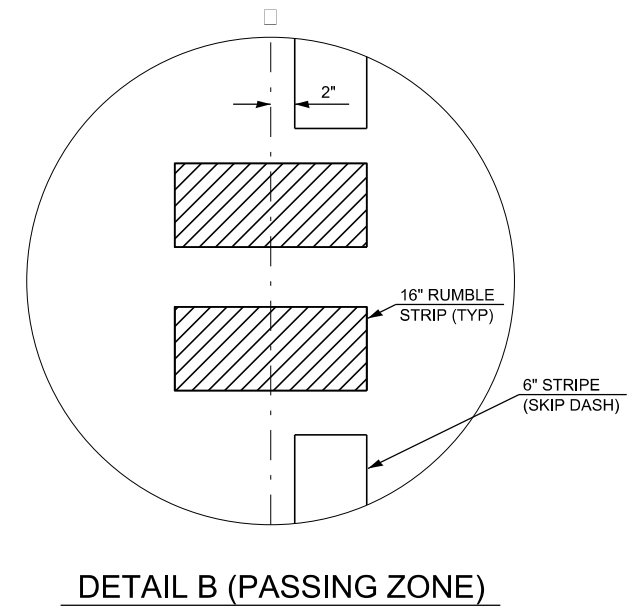

600-1

MODEL: det 3 detailb  
FILE: \\miller\paw\centerline\DOT Documents\DOT Office\DH\det 3\Projects\600-1\Detail\03 Detail Rev\600-1.dgn

USER NAME = anthony.grunstad	DESIGNED -	REVISED -
	DRAWN -	REVISED -
PLOT SCALE = 100,000 ' / in.	CHECKED -	REVISED -
PLOT DATE = 10/3/23	DATE -	REVISED -

STATE OF ILLINOIS  
DEPARTMENT OF TRANSPORTATION

CENTERLINE RUMBLE STRIP DETAIL

SCALE: SHEET OF SHEETS STA. TO STA.

F.A.P. RTE.	SECTION	COUNTY	TOTAL SHEETS	SHEET NO.
-	-	-	-	-
CONTRACT NO.				
ILLINOIS FED. AID PROJECT				