

TYPICAL CURB INSTALLATION
ON TOP OF EXISTING PAVEMENT

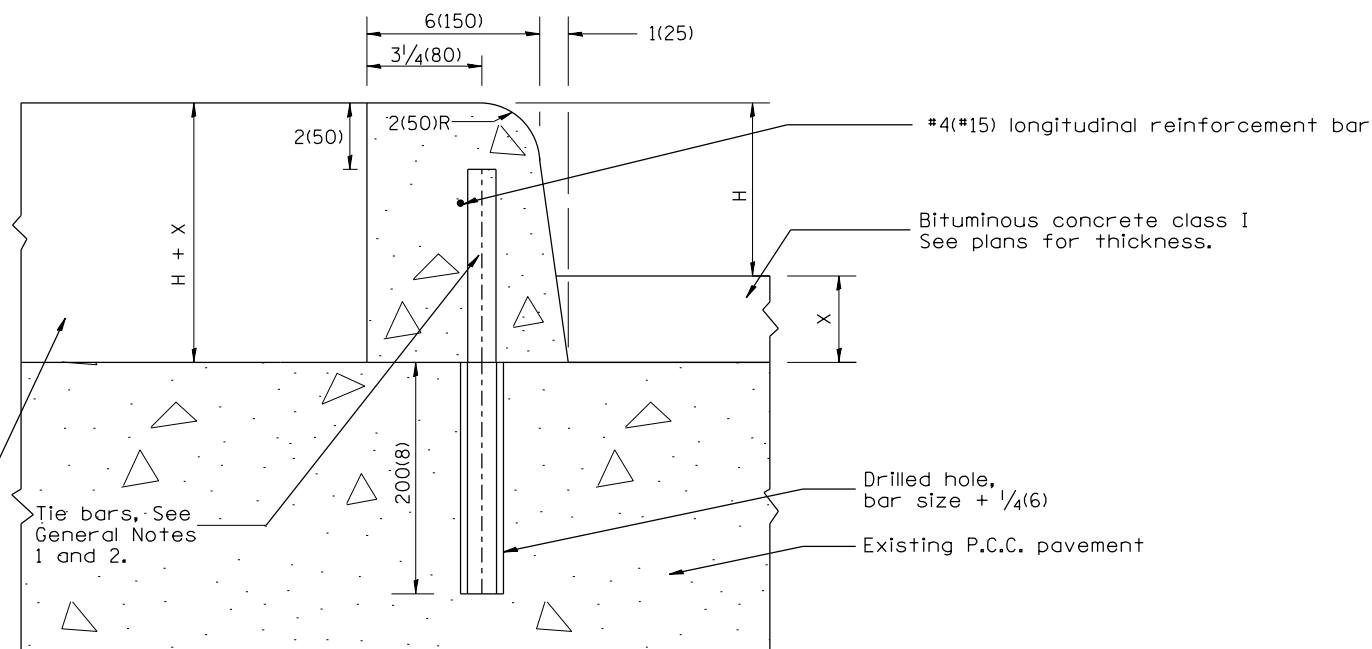

LEGEND

- H = curb height: 6(150) or 9(225).
(see plans for curb height)
- X = thickness of bituminous resurfacing.
(see plans for thickness)
- T = thickness of existing P.C.C. pavement.
(see plans for thickness)

GENERAL NOTES:

1. Tie bars shall be #6(#20) at 24(600mm) center in accordance with details for longitudinal construction joint shown in Standard 420001.
2. A minimum clearance of 2(50mm) between the end of the tie bar and the back or top of the curb shall be maintained.
3. Drainage openings 1 sq. ft.(0.1m²) in area shall be cut through existing concrete within median along curb at 20'(6.1m) centers and at low points.
4. CONCRETE CURB, TYPE B (MODIFIED) shall be constructed in accordance with the applicable portions of Standards 420001 and 606001, and in accordance with the applicable portions of Article 420.10 and Section 606 of the Standard Specifications except as noted herein.

Backfill as shown elsewhere on plans

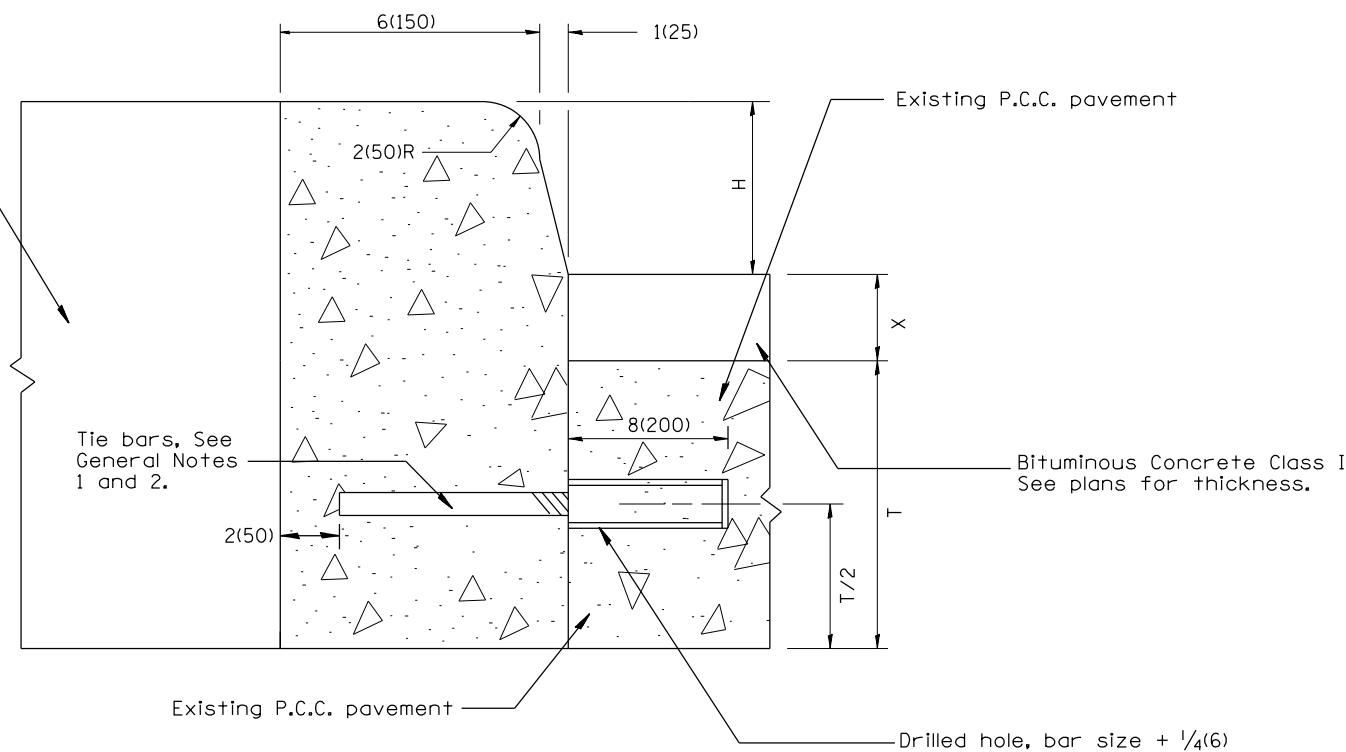

TYPICAL CURB INSTALLATION
AT EDGE OF EXISTING PAVEMENT

DESIGNER NOTE: 1. INCLUDE STATE STANDARDS 420001 AND 606001.

All dimensions are in inches (millimeters) unless otherwise noted.

01-01-97	RENUM. A-7.10, NEW REVISION BOX, NEW FORMAT,	T.P.
	REVISED NOTES, ELIMINATED EXPANSION TIE ANCHORS	
03-31-99	REMOVED EPOXY COAT REQUIREMENT	J.A.
10-16-06	REVISED TO 2007 SPEC.	M.A.

STATE OF ILLINOIS
DEPARTMENT OF TRANSPORTATION

CONCRETE CURB, TYPE B (MODIFIED)

NOT TO SCALE

CADD STD. 606001-D4

F.A. RTE.	SECTION	COUNTY	TOTAL SHEETS	SHEET NO.
CONTRACT NO.				
FED. ROAD DIST. NO. ILLINOIS FED. AID PROJECT				