

DESIGNER NOTES: 1. Include State Standard 606001 for combination concrete curb and gutter details.
 2. Include State Standard 420001 for pavement joints.
 3. Include District CADD Standard for frame and grates.
 4. Include District Special Provision. Pay item includes transitional c.c.&g., inlet and frame and grate. All work within pay limits.
 5. Specify grate type in plans

MODEL: SHT_PLAN
 FILE NAME: C:\Bentley\CONNECT101\Organization\Chil\IDOT_Standards\Call\IDOT_Sheets.dwg

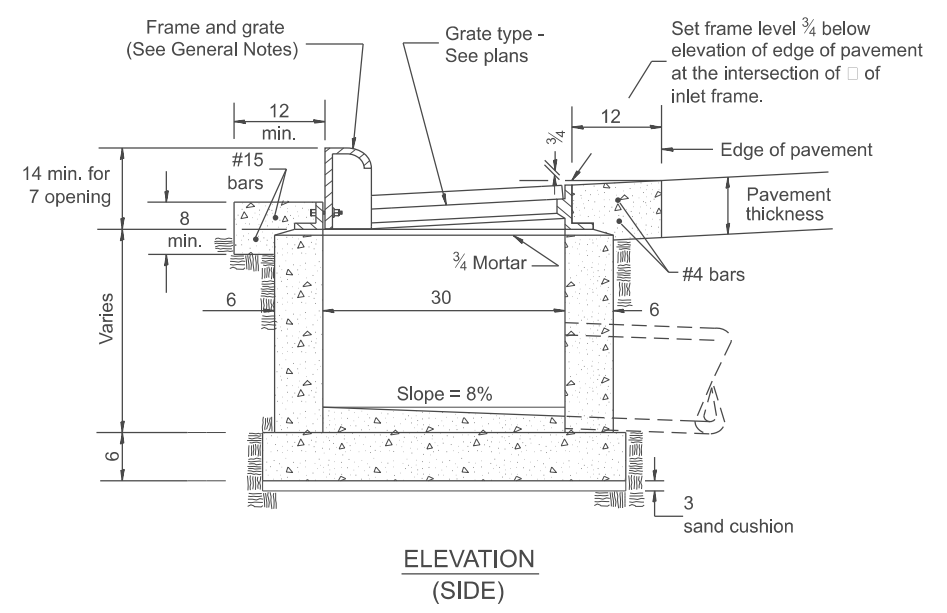
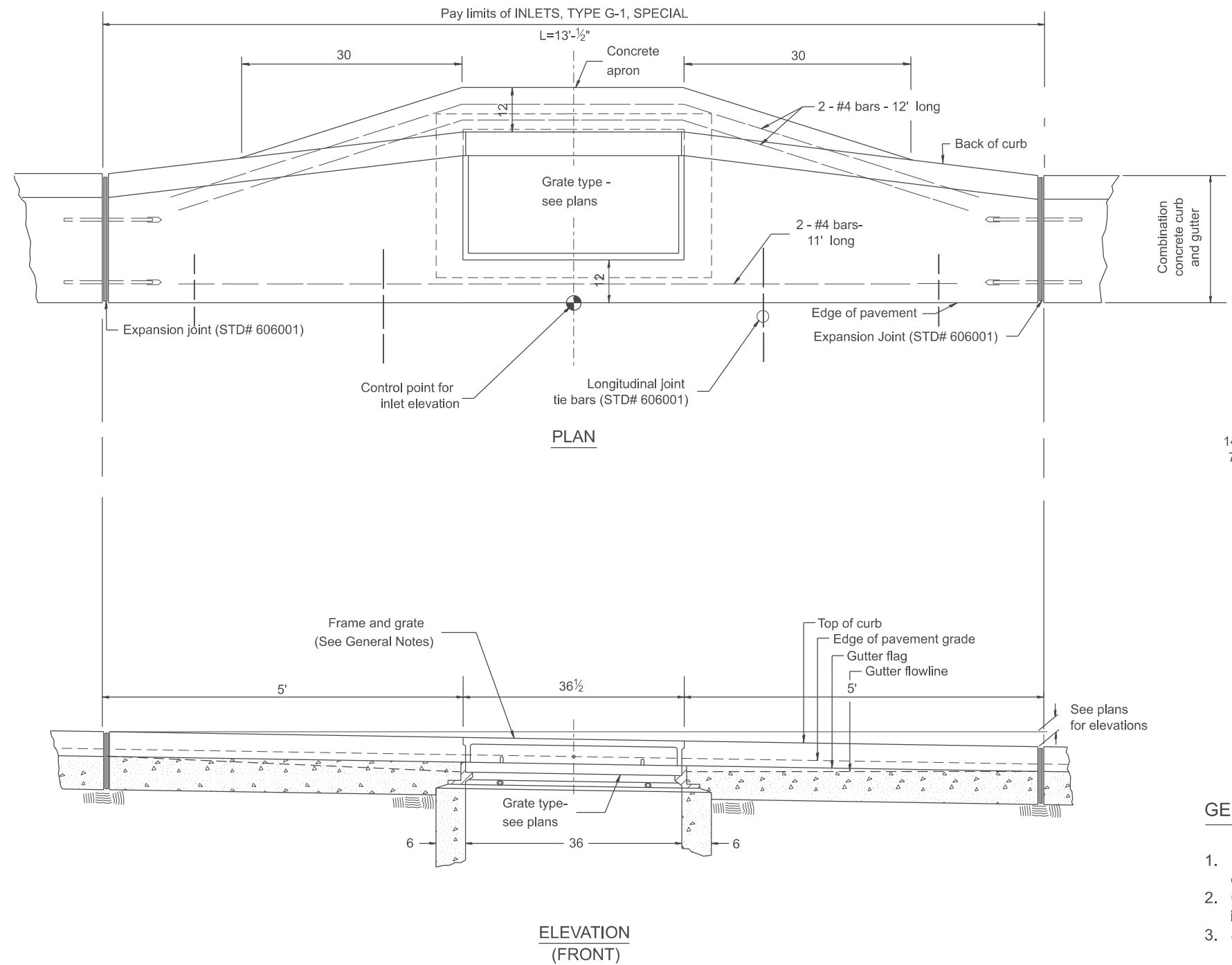

GENERAL NOTES

1. Inlet construction shall be in accordance with Section 602 of the Standard Specifications.
2. Combination Concrete Curb and Gutter shall be constructed in accordance with Section 606 of the Standard Specifications.
3. See District CADD Standard 604001-D4 for frame and grates.

All dimensions are in inches unless otherwise noted.

USER NAME = Eric.Thomas	DESIGNED -	REVISED -
	DRAWN -	REVISED -
	CHECKED -	REVISED -
PLOT DATE = 12/7/2022	DATE -	REVISED -

**STATE OF ILLINOIS
 DEPARTMENT OF TRANSPORTATION**

INLETS, TYPE G-1, SPECIAL

SCALE: NOT TO SCALE SHEET OF SHEETS STA. TO STA.

F.A. RTE.	SECTION	COUNTY	TOTAL SHEETS	SHEET NO.
DISTRICT 4 DETAIL NO. 602006			CONTRACT NO.	
ILLINOIS FED. AID PROJECT				