

F.A.U. RTE.	SECTION	COUNTY	TOTAL SHEETS	SHEET NO.
3578	15V B-1-R-1	COOK	243	136
STA.		TO STA.		
FED. ROAD DIST. NO.		ILLINOIS FED. AID PROJECT		
CONTRACT NO. 62388				

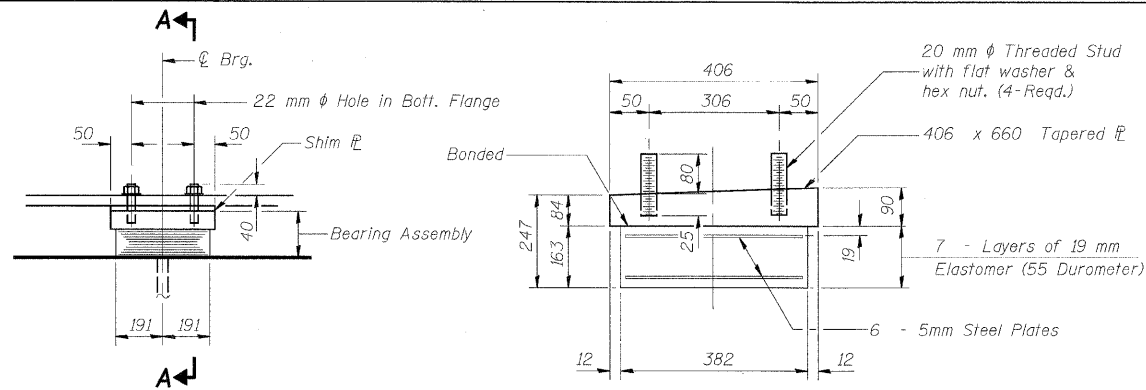

ELEVATION AT PIER 1

PIER 1 BEARING ASSEMBLY

PIER 1 TYPE I ELASTOMERIC EXP. BRG.

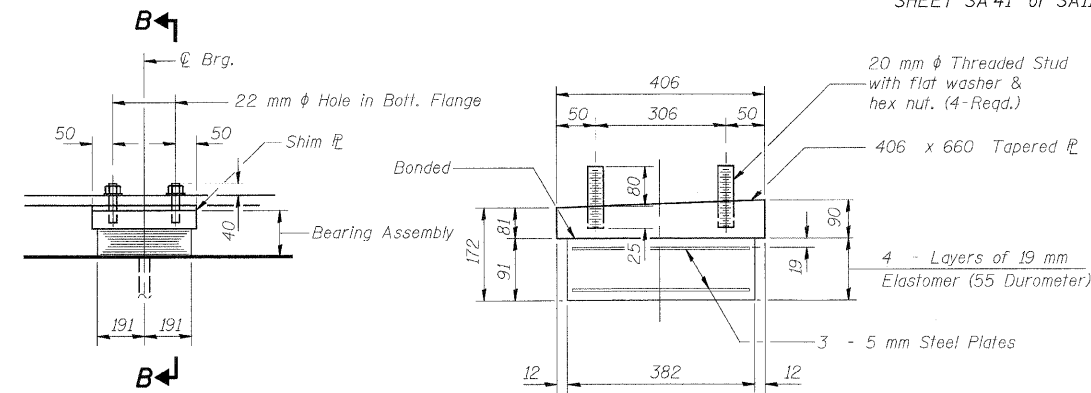

ELEVATION AT PIER 2

PIER 2 BEARING ASSEMBLY

PIER 2 TYPE I ELASTOMERIC EXP. BRG.

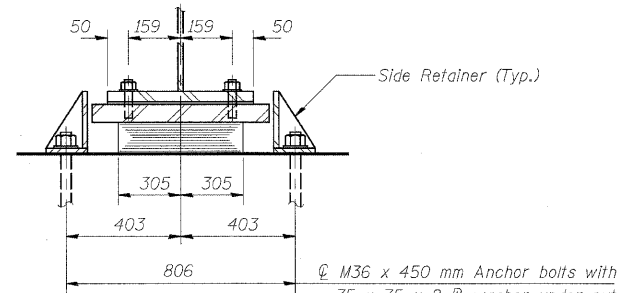

SECTION A-A

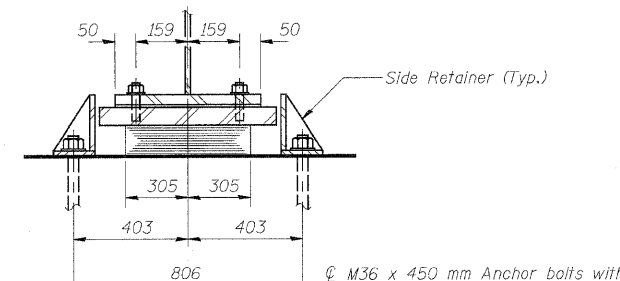

SECTION B-B

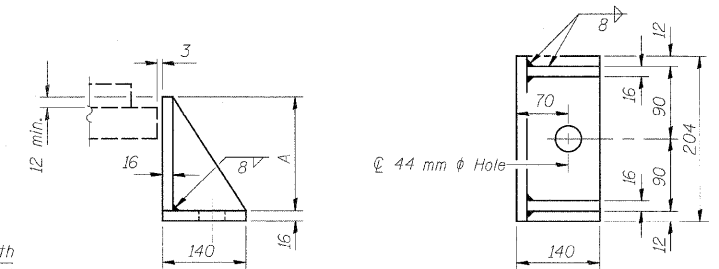

SIDE RETAINER

Equivalent rolled angle with stiffeners will be allowed in lieu of welded plates.

	PIER 1	PIER 2	PIER 4	PIER 5
A	249	177	134	208

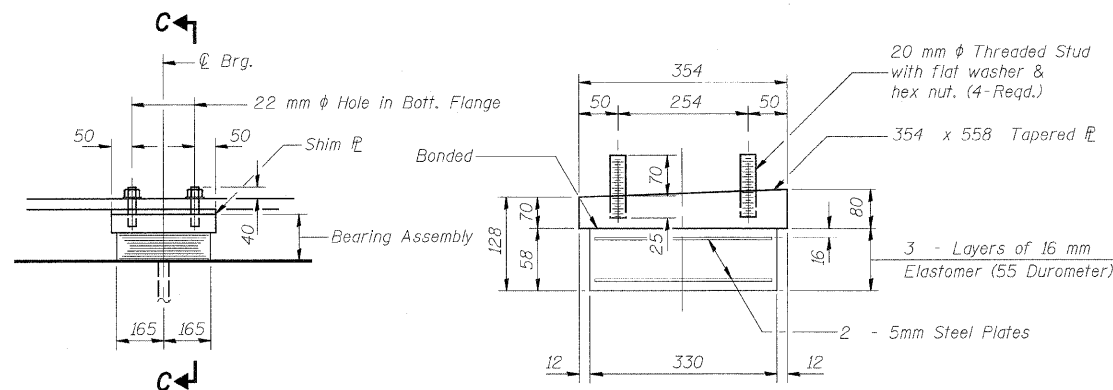

ELEVATION AT PIER 4

PIER 4 BEARING ASSEMBLY

PIER 4 TYPE I ELASTOMERIC EXP. BRG.

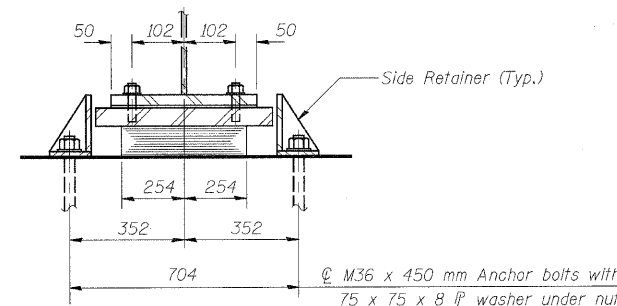

SECTION D-D

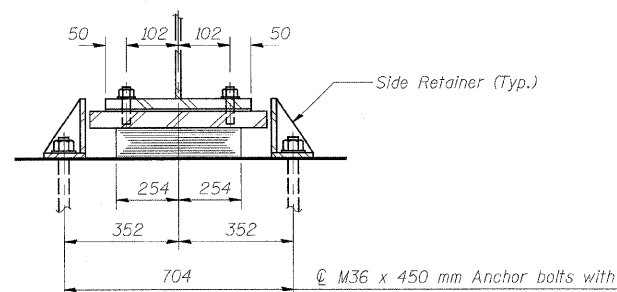

SECTION C-C

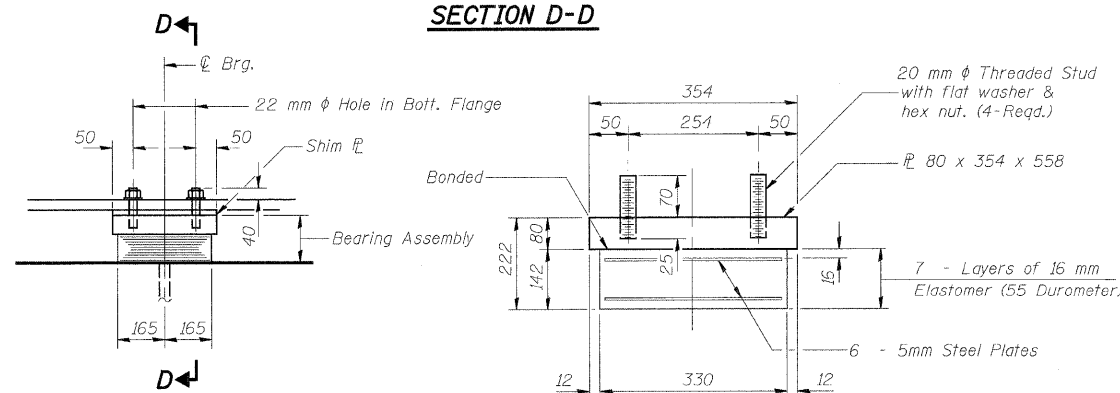

ELEVATION AT PIER 5

PIER 5 BEARING ASSEMBLY

PIER 5 TYPE I ELASTOMERIC EXP. BRG.

NOTES

- See sheet #SA46 for Anchor Bolt installation.
- All dimensions are in millimeters (mm) except as noted.
- Shim plates shall not be placed under bearing assembly.
- Side retainers and other steel members required for the bearing assembly shall be included in the cost of Elastomeric Bearing Assembly, Type I.

REVISIONS	
NAME	DATE

ILLINOIS DEPARTMENT OF TRANSPORTATION
 BEARING DETAILS - UNIT I
 PIERS 1, 2, 4 & 5
 SOUTHWEST HIGHWAY OVER
 B&O RAILROAD AND STONY CREEK
 FAU 3578 SECTION 15V B-1-R-1
 STRUCTURE NUMBER 016-2771
 COOK COUNTY STATION 4+716.497
 SCALE: NONE DRAWN BY: E. Mroozek
 DATE: 6/17/09 CHECKED BY: G. Hattestad

H:\open\rdwy_lisle\6/26/2009 8:22:20 AM
 Q:\VDDT\9556_A0\Drawings\STRUCT\41_brgs_Pier_L2_4_5.dgn