

F.A.P. RTE.	SECTION	COUNTY	TOTAL SHEETS	SHEET NO.
326	*	McHENRY	502	27
STA. 9+35.22		TO STA. 142+08.53		
FED. ROAD DIST. NO.		ILLINOIS	FED. AID PROJECT	

* (105X & 106) WRS-2

ALIGNMENT COORDINATE TABLE

DESCRIPTION	NORTHING	EASTING
IL ROUTE 47		
POT STA 4+61.19	1,997,050.49	957,283.86
PC CURVE P-1	1,998,050.49	957,282.60
PCC CURVE P-1/P-2	1,999,037.03	957,451.12
PT CURVE P-2	1,999,642.04	957,760.13
PC CURVE P-3	1,999,812.07	957,878.31
PT CURVE P-3	2,000,917.16	958,279.20
POT STA 69+33.62	2,003,297.19	958,490.67
POT STA 75+89.87	2,003,950.87	958,548.75
PC CURVE P-4	2,004,289.89	958,578.87
PRC CURVE P-4/P-5	2,005,172.60	958,684.90
PT CURVE P-5	2,006,589.00	958,791.02
POT STA 102+41.17	2,006,589.01	958,791.02
PC CURVE P-6	2,006,935.26	958,790.71
PT CURVE P-6	2,007,930.66	959,128.94
PC CURVE P-7	2,008,825.68	959,810.77
PT CURVE P-7	2,009,845.37	960,148.80
POT STA 142+31.92	2,010,200.03	960,141.21
POT STA 158+82.50	2,011,850.41	960,115.21
KREUTZER ROAD (WEST)		
POT STA 329+84.00	1,998,670.48	957,128.38
POT STA 330+78.32	1,998,670.48	957,222.70
POT STA 332+03.30	1,998,670.48	957,347.68
KREUTZER ROAD (EAST)		
POT STA 199+94.60	1,998,666.52	957,346.84
POT STA 207+44.61	1,998,662.47	958,096.84
DEAN STREET		
POT STA 300+00.00	2,000,426.76	958,180.83
PC CURVE D-1	2,000,423.82	958,245.31
PT CURVE D-1	2,000,491.20	958,427.69
POT STA 306+23.58	2,000,737.91	958,690.79
MILL STREET		
PC CURVE M-1	2,002,649.05	957,679.53
PRC CURVE M-1/M-2	2,002,640.28	957,744.86
PT CURVE M-2	2,002,630.29	957,840.32
PC CURVE M-3	2,002,632.47	958,689.05
PT CURVE M-3	2,002,685.59	958,847.53
POT STA 406+57.24	2,002,823.54	959,031.18
MAIN STREET		
POT STA 489+99.58	2,003,952.71	957,548.33
POT STA 507+62.73	2,003,949.47	959,311.48
CORAL STREET		
POT STA 600+00.00	2,004,209.83	958,571.76
PC CURVE C-1	2,004,135.00	958,619.94
PT CURVE C-1	2,004,064.82	958,766.94
POT STA 603+06.57	2,004,069.77	958,812.73
POT STA 604+59.97	2,004,069.96	958,966.13
DWYER STREET		
POT STA 700+00.00	2,003,950.43	958,788.36
POT STA 701+16.41	2,004,066.80	958,785.25
BORDON STREET		
POT STA 7+97.74	2,004,779.41	958,428.68
POT STA 10+00.00	2,004,780.33	958,630.94
4TH STREET		
POT STA 7+96.26	2,005,229.18	958,489.62
POT STA 10+00.00	2,005,229.53	958,693.36

DESCRIPTION	NORTHING	EASTING
NORTH AVENUE		
POT STA 8+76.82	2,005,883.53	958,641.94
POT STA 12+07.74	2,005,883.05	958,972.86
ALGONQUIN ROAD		
POT STA 86+89.97	2,006,586.27	957,482.62
POT STA 95+39.37	2,006,573.20	958,331.92
POT STA 99+98.67	2,006,558.95	958,791.00
POT STA 104+56.27	2,006,547.88	959,248.46
POT STA 127+05.86	2,006,532.84	961,498.00
KENNETH STREET		
POT STA 10+00.00	2,007,147.89	958,804.38
POT STA 12+07.01	2,007,147.39	959,011.38
JOAN STREET		
POT STA 5+37.14	2,008,164.93	958,786.32
PC CURVE J-1	2,008,165.22	958,962.08
PT CURVE J-1	2,008,103.60	959,144.70
POT STA 12+00.06	2,007,926.97	959,375.89
REED ROAD		
POT STA 687+12.65	2,009,211.24	958,821.37
PC CURVE R-1	2,009,208.23	959,140.61
PT CURVE R-1	2,009,268.13	959,404.52
PC CURVE R-2	2,009,318.93	959,508.15
PCC CURVE R-2/R-3	2,009,370.36	959,649.99
PT CURVE R-3	2,009,365.99	959,924.39
POT STA 700+00.00	2,009,325.25	960,070.58
PC CURVE R-4	2,009,291.13	960,178.33
PT CURVE R-4	2,009,279.46	960,254.19
POT STA 711+27.37	2,009,280.86	961,192.00

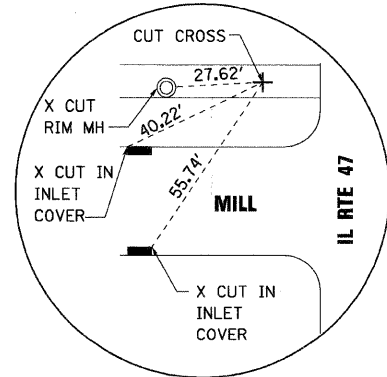

TIE POINT #1
CP #18:
N 2006256.675
E 958107.154

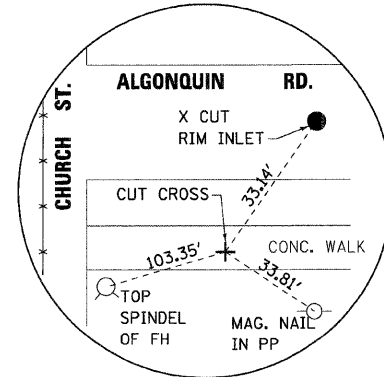

TIE POINT #2
CP #31
N 2006534.416
E 959535.154

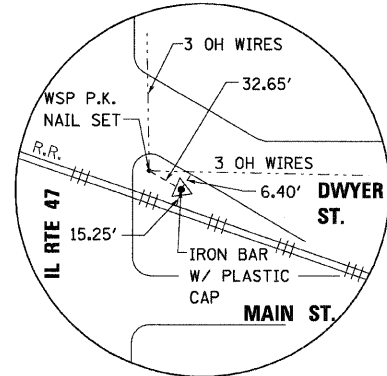

TIE POINT #3
CP #245
N 2004078.4178
E 958623.8943

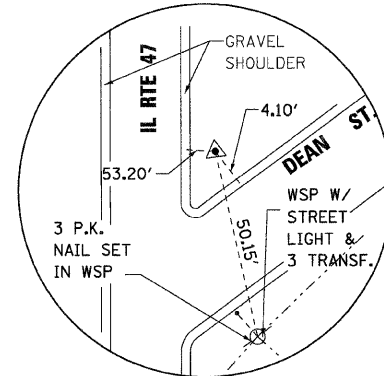

TIE POINT #4
CP #265
N 2000406.6366
E 958242.8953

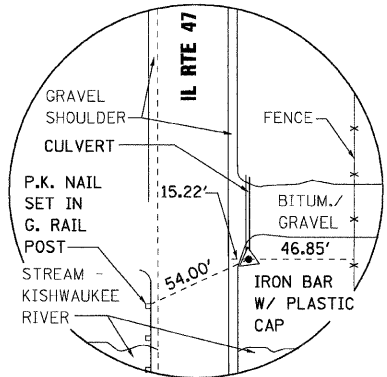

TIE POINT #5
CP #270
N 2006535.7219
E 958828.1248

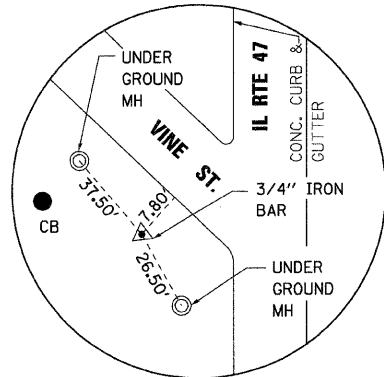

TIE POINT #6
CP #303
N 2007415.528
E 958804.6273

BENCHMARKS:

- BM #8 CUT "□" ON TOP OF SOUTHEAST ABUTMENT OF IL ROUTE 47 BRIDGE OVER THE SOUTH BRANCH OF THE KISHWAUKEE RIVER JUST NORTH OF KREUTZER ROAD. ELEV = 877.460
- BM #9 CHISLED "X" ON BOLT ON HYDRANT ON THE EAST SIDE OF IL ROUTE 47 JUST NORTH OF DEAN STREET. ELEV = 882.753
- BM #10 CHISLED "X" ON NORTHERLY BOLT ON HYDRANT AT THE NORTHEAST CORNER OF IL ROUTE 47 AND MILL STREET. ELEV = 895.092
- BM #11 CUT "□" IN THE NORTHEAST CORNER OF A HANDHOLE CONCRETE BASE AT THE NORTHEAST CORNER OF IL ROUTE 47 AND MAIN STREET. ELEV = 889.936
- BM #12 CUT "□" ON A TRAFFIC SIGNAL BASE AT THE NORTHWEST CORNER OF IL ROUTE 47 AND ALGONQUIN ROAD. ELEV = 893.714

REVISIONS	
NAME	DATE

ILLINOIS DEPARTMENT OF TRANSPORTATION
ILLINOIS ROUTE 47
ALIGNMENT, TIES AND BENCHMARKS
SHEET 3 OF 3



SCALE: VERT. NO SCALE
 HORIZ. DATE: 8/5/2009
 DRAWN BY: E.D.
 CHECKED BY: A.A.C.

PLOT DATE = Wednesday, August 05, 2009
 FILE NAME = S:\11-CADD\11-11-08\11-11-08.dwg
 PLOT SCALE = 2500
 USER NAME = 3530