

F.A.U. RTE.	SECTION	COUNTY	TOTAL SHEETS	SHEET NO.
320	07-00138-26-TL	WILL	19	14
STA.		TO STA.		
FED. ROAD DIST. NO		ILLINOIS	FED AID PROJECT CMM-9003(023)	
C-91-405-08				

**SCHEDULE OF QUANTITIES** CONTRACT NO. 63329

PAY ITEM	UNIT	QUANTITY
72000100	SQ FT	28.5
81000600	FOOT	584
81000700	FOOT	30
81000800	FOOT	8
81001100	FOOT	10
81018500	FOOT	71
81018600	FOOT	87
81018900	FOOT	336
81019000	FOOT	28
81400700	EACH	4
81400710	EACH	5
81400720	EACH	2
81900200	FOOT	934
85700200	EACH	1
86200200	EACH	1
87301215	FOOT	1316
87301225	FOOT	1904
87301245	FOOT	921
87301255	FOOT	1760
87301305	FOOT	1884
87301805	FOOT	95
87502500	EACH	3
87700160	EACH	1
87700250	EACH	1
87700270	EACH	1
87700310	EACH	1
87800100	FOOT	12
87800150	FOOT	4
87800400	FOOT	15
87800415	FOOT	45
88030020	EACH	4
88030100	EACH	4
88030110	EACH	4
88102710	EACH	6
88102740	EACH	1
88200110	EACH	8
88500100	EACH	8
88600100	FOOT	1052
88700200	EACH	2
88700300	EACH	1
88800100	EACH	7
X8050015	EACH	1
X8730250	FOOT	330
X8730027	FOOT	1173

**CABLE PLAN LEGEND**

EXISTING	PROPOSED	DESCRIPTION
G	G	8" (200mm) TRAFFIC SIGNAL SECTION
R	R	12" (300mm) TRAFFIC SIGNAL SECTION
W	W	12" (300mm) PEDESTRIAN SIGNAL SECTION
[Symbol]	[Symbol]	12" (300mm) PEDESTRIAN SIGNAL SECTION
[Symbol]	[Symbol]	CONTROLLER CABINET
[Symbol]	[Symbol]	SERVICE INSTALLATION
[Symbol]	[Symbol]	TELEPHONE CONNECTION
[Symbol]	[Symbol]	VEHICLE DETECTOR, INDUCTION LOOP
[Symbol]	[Symbol]	MAGNETIC DETECTOR
[Symbol]	[Symbol]	EMERGENCY VEHICLE LIGHT DETECTOR
[Symbol]	[Symbol]	CONFIRMATION BEACON
[Symbol]	[Symbol]	PUSHBUTTON DETECTOR
[Symbol]	[Symbol]	2 DENOTES NUMBER OF CONDUCTORS. ALL CABLE NO. 14 EXCEPT AS INDICATED. ALL LOOP DETECTOR CABLE TO BE SHIELDED.
[Symbol]	[Symbol]	1 GROUND CABLE IN CONDUIT, NO. 6 SOLID COPPER (GREEN)
[Symbol]	[Symbol]	24 FIBER OPTIC CABLE IN CONDUIT, NO. 62.5/125 2-MM12F SM12F
[Symbol]	[Symbol]	SIGNAL FACE WITH BACKPLATE. "P" INDICATES PROGRAMMED HEAD
[Symbol]	[Symbol]	RAILROAD CONTROL CABINET
[Symbol]	[Symbol]	ILLUMINATED SIGN, "NO LEFT TURN"
[Symbol]	[Symbol]	ILLUMINATED SIGN, "NO RIGHT TURN"
[Symbol]	[Symbol]	GROUND CABLE 1C NO.6
[Symbol]	[Symbol]	GROUND ROD AT HANDHOLE (H), DOUBLE HANDHOLE (HI), OR CONTROLLER (C)
[Symbol]	[Symbol]	GROUND ROD AT POST (P), OR MAST ARM POLE (MA)
[Symbol]	[Symbol]	GROUND ROD AT ELECTRIC SERVICE INSTALLATION
[Symbol]	[Symbol]	UNINTERRUPTIBLE POWER SUPPLY

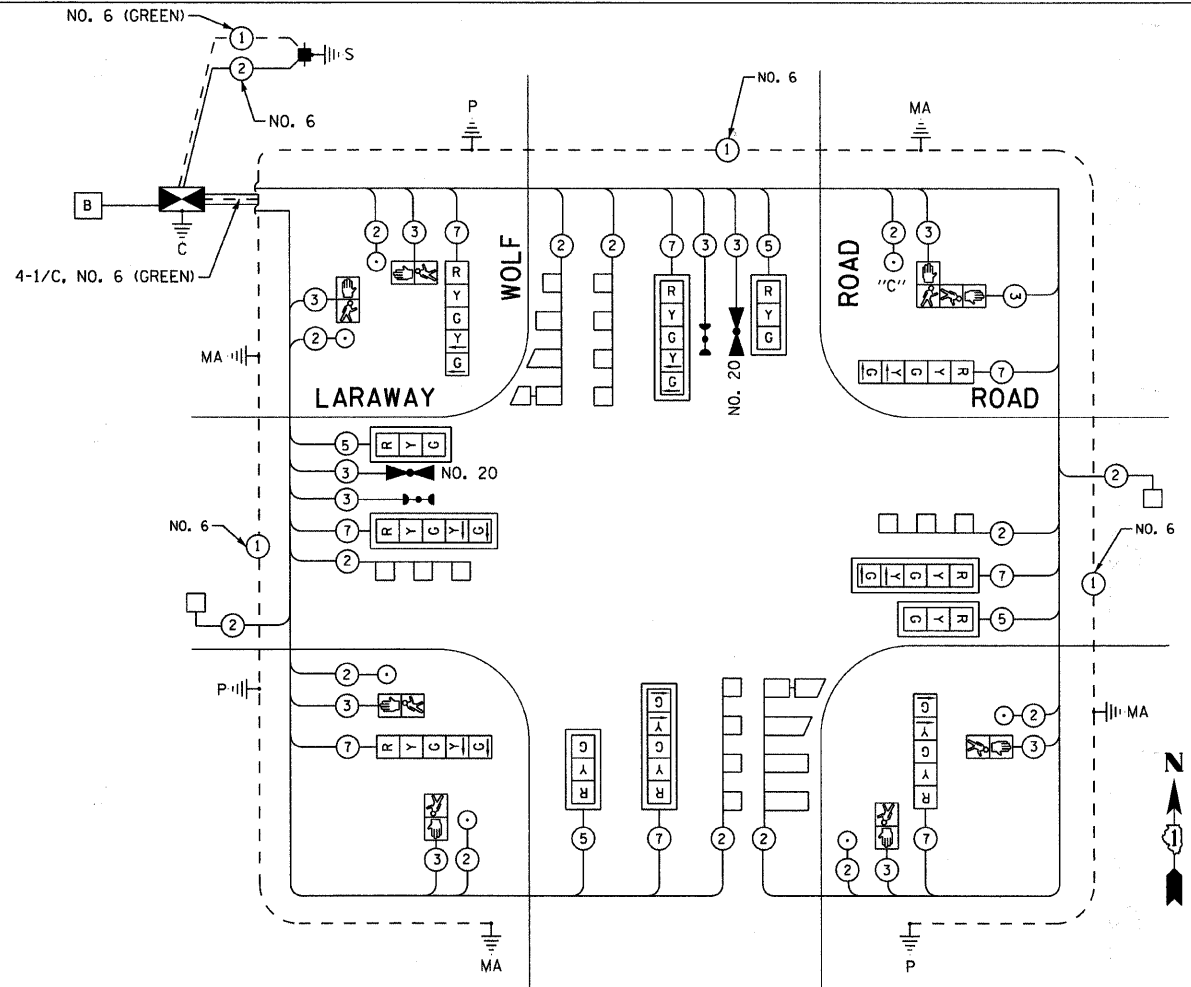

**CABLE PLAN**  
(NOT TO SCALE)

**PEDESTRIAN PUSH BUTTON NOTES**

PUSH BUTTON "C" SHALL PLACE A CALL IN PHASES 6 AND 8.

**CONTROLLER SEQUENCE**

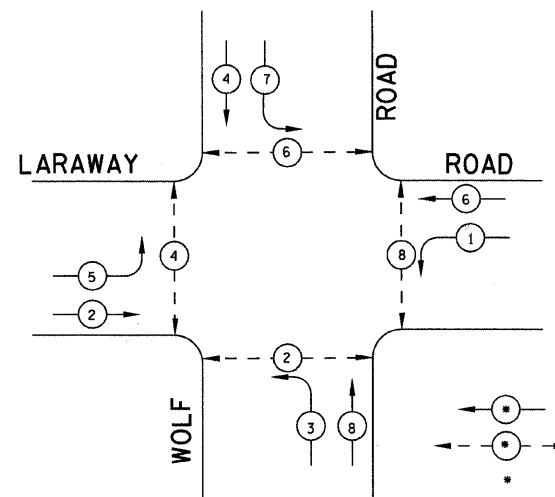

**EMERGENCY VEHICLE PREEMPTION SEQUENCE**

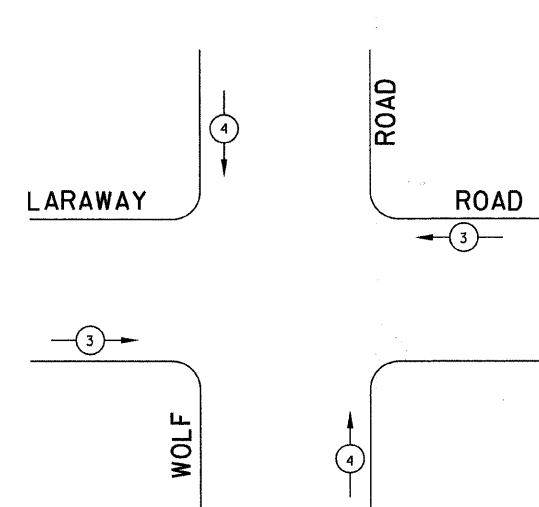

**LEGEND**

[Symbol]	DUAL ENTRY PHASE
[Symbol]	PEDESTRIAN PHASE
[Symbol]	NUMBER REFERS TO ASSOCIATED PHASE

**PHASE DESIGNATION DIAGRAM**

FOUNDATION (DEPTH)	FT. (m)	CABLE SLACK	FT. (m)	VERTICAL	FT. (m)
TYPE A - POST	4 (1.2)	HANDHOLE	6.5 (2.0)	ALL FOUNDATIONS	3.5 (1.0)
C - CONTROLLER	4 (1.2)	DOUBLE HANDHOLE	13 (4.0)	MAST ARM (L) POLE	20'±L-2'
E - M. ARM POLE		SIGNAL POST	2 (0.5)	BRACKET MOUNTED	(6m±L-0.6m)±
24" (600mm)	10 (3.0)	CONTROLLER CAB.	1 (0.5)	PED. PUSHBUTTON	4 (1.2)
30" (750mm)	15 (4.6)	FIBER OPTIC	13 (4.0)	ELECTRIC SERVICE	13.5 (4.1)
36"	15 (4.6)	ELECTRIC SERVICE	1 (0.5)	SERVICE TO GROUND	13.5 (4.1)
		GROUND CABLE	1 (0.5)	POST MOUNTED	6 (1.8)

**TRAFFIC SIGNAL NOTES:**

1. THE TRAFFIC SIGNAL CONTROLLER SHALL BE "ECONOLITE".
2. THE NEUTRAL AND GROUND SHALL BE TIED AT THE SERVICE INSTALLATION, BUT SHALL BE SEPARATED AT THE TRAFFIC SIGNAL CABINET.

I.D.O.T TRAFFIC SIGNAL INSTALLATION ELECTRICAL SERVICE REQUIREMENTS					TOTAL WATTAGE
TYPE	NO. LAMPS	WATTAGE INCAND.	LED	%OPERATION	
SIGNAL (RED)	12	17		0.50	102
(YELLOW)	12	25		0.25	75
(GREEN)	12	15		0.25	45
ARROW	16	12		0.10	19.2
PED. SIGNAL	8	25		1.00	200
CONTROLLER	1	100		1.00	100.00
UPS	1	25		1.00	25
FLASHER				0.50	--
TOTAL =					566.20

ENERGY COSTS TO: TOTAL =  
 WILL COUNTY DEPARTMENT OF HIGHWAYS  
 16841 WEST LARAWAY ROAD  
 JULIET, ILLINOIS 60433  
 ENERGY SUPPLY CONTACT: KRISHNA KIRKLAND  
 PHONE: (815) 724-5805  
 COMPANY: COM. ED.

PROPOSED EMERGENCY VEHICLE PREEMPTION	
EMERGENCY VEHICLE PREEMPTION	3 4
MOVEMENT	← → ↑ ↓

REVISIONS	
NAME	DATE
PER COUNTY	8-20-09
PER IDOT	9-16-09

ILLINOIS DEPARTMENT OF TRANSPORTATION  
**TRAFFIC SIGNAL CABLE PLAN AND PHASE DESIGNATION DIAGRAM**  
**LARAWAY ROAD AT WOLF ROAD**  
 PROJECT NO. 071621 DESIGNED BY: RWL  
 SCALE: NONE DRAWN BY: BCD  
 DATE: 06/25/09 CHECKED BY: NJP



COPYRIGHT © 2008 BY BAXTER & WOODMAN, INC.  
 STATE OF ILLINOIS - PROFESSIONAL DESIGN FIRM  
 LICENSE NO. 015-0709  
 566023  
 \\cortb.baxwood.com\projects\m071621\1-rwy at wolf\cadd\sur\wfy\drawings\dgn\071621-15-Cable.plt