

**LEGEND**

- ① EXISTING PAVEMENT:
  - HMA T=3"-4"
  - AGGREGATE BASE COURSES 7"-12"
- ② EXISTING COMBINATION AGGREGATE/TURF SHOULDER
- ③ EXISTING COMBINATION HMA/AGGREGATE SHOULDER
- ④ EXISTING CONCRETE CURB AND GUTTER
- ⑤ PROPOSED CLASS D PATCHES, 6"
- ⑥ PROPOSED HMA SURFACE COURSE, MIX "C", N50, 1 1/2"
- ⑦ PROPOSED AGGREGATE SHOULDERS, TYPE B
- ⑧ PROPOSED LANDSCAPING:
  - TOPSOIL FURNISH AND PLACE, 3"
  - SEEDING CLASS 1
  - EROSION CONTROL BLANKET
- ⑨ PROPOSED (AVERAGE) LEVELING BINDER (MACHINE METHOD) N50, 1"
- ⑩ PROPOSED THERMOPLASTIC PAVEMENT MARKING LINE
  - a. 2-4" YELLOW CENTERLINE
  - b. 6" WHITE EDGE LINE
- ⑪ PROPOSED EARTH EXCAVATION
- ⑫ PROPOSED HOT MIX ASPHALT SHOULDERS, 2 1/4"
- ⑬ PROPOSED HMA SURFACE REMOVAL, 1 1/2"
- ⑭ PROPOSED AREA REFLECTIVE CRACK CONTROL TREATMENT
- ⑮ PROPOSED HOT-MIX ASPHALT DRIVEWAY PAVEMENT, 3"
- ⑯ PROPOSED DRIVEWAY PAVEMENT REMOVAL
- ⑰ PROPOSED SAWING ASPHALT SURFACE

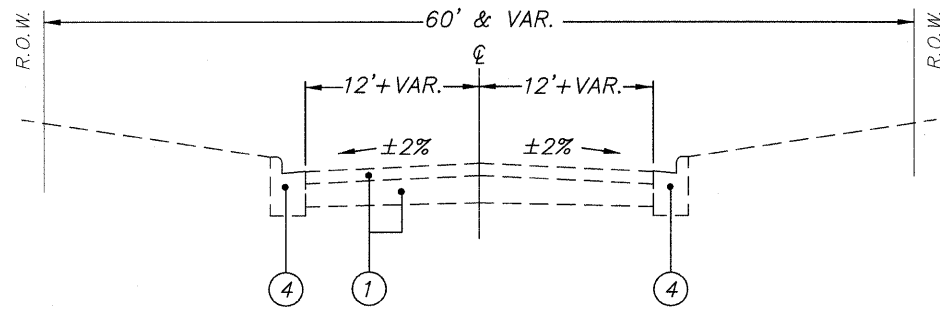

**EXISTING TYPICAL SECTION**  
 STA 100+32-101+53  
 STA 146+36-149+22

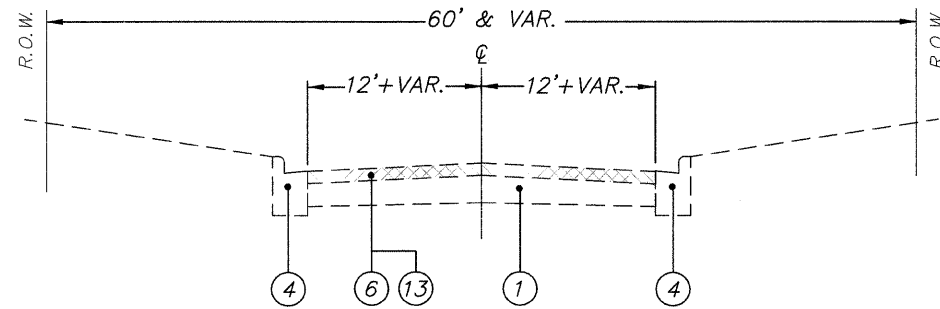

**PROPOSED TYPICAL SECTION**  
 STA 100+32-101+53  
 STA 146+36-149+22

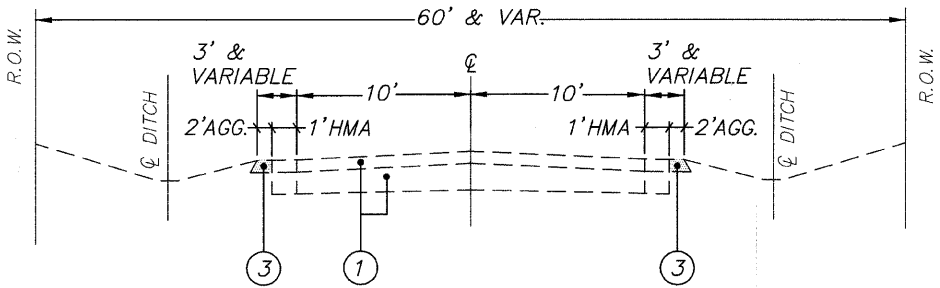

**EXISTING TYPICAL SECTION**  
 STA 101+53-123+00

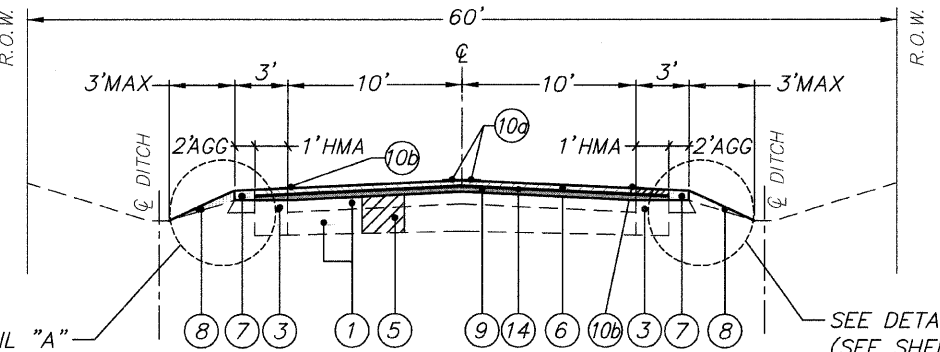

**PROPOSED TYPICAL SECTION**  
 STA 101+53-123+00

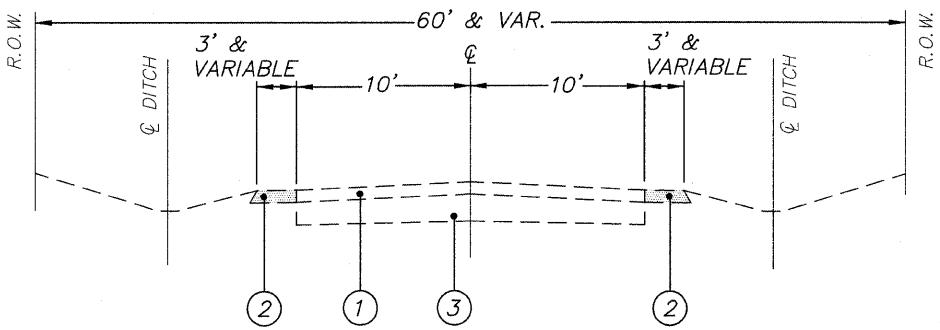

**EXISTING TYPICAL SECTION**  
 STA 123+00-146+36

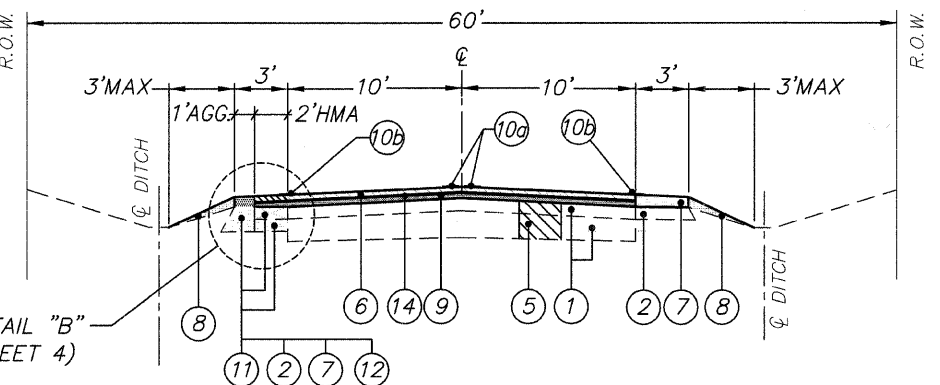

**PROPOSED TYPICAL SECTION**  
 STA 123+00-146+36

HOT MIX ASPHALT MIXTURE REQUIREMENT	
MIXTURE TYPE	AIR VOIDS @ Ndes
<b>PATCHING</b>	
CLASS D PATCHES (HMA BINDER IL-19mm)	4% @ 50 Gyr
<b>DRIVEWAYS</b>	
HOT-MIX ASPHALT SURFACE COURSE, MIX "C", N50 (IL-9.5mm), 3"	4% @ 50 Gyr
<b>PAVEMENT RESURFACING</b>	
HOT-MIX ASPHALT SURFACE COURSE, MIX C, N50 (IL-9.5mm)	4% @ 50 Gyr
LEVELING BINDER (MACHINE METHOD), N50	4% @ 50 Gyr
<b>SHOULDERS</b>	
HOT-MIX ASPHALT BINDER COURSE, IL-19.0, N50	4% @ 50 Gyr

THE UNIT WEIGHT USED TO CALCULATE ALL HMA SURFACE MIXTURE QUANTITIES IS 112 LBS/SQ YD/IN.

THE "AC TYPE" FOR POLYMERIZED HMA MIXES SHALL BE "SBS/SBR PG 70-22" AND FOR NON-POLYMERIZED HMA THE "AC TYPE" SHALL BE "PG 64-22" UNLESS MODIFIED BY DISTRICT ONE SPECIAL PROVISIONS. FOR "PERCENT OF RAP" SEE DISTRICT ONE SPECIAL PROVISIONS.