

PNT 96 POT STA. 26+33.23 RAMP MW =
 PNT 98 POT STA. 20+95.54 CH 4

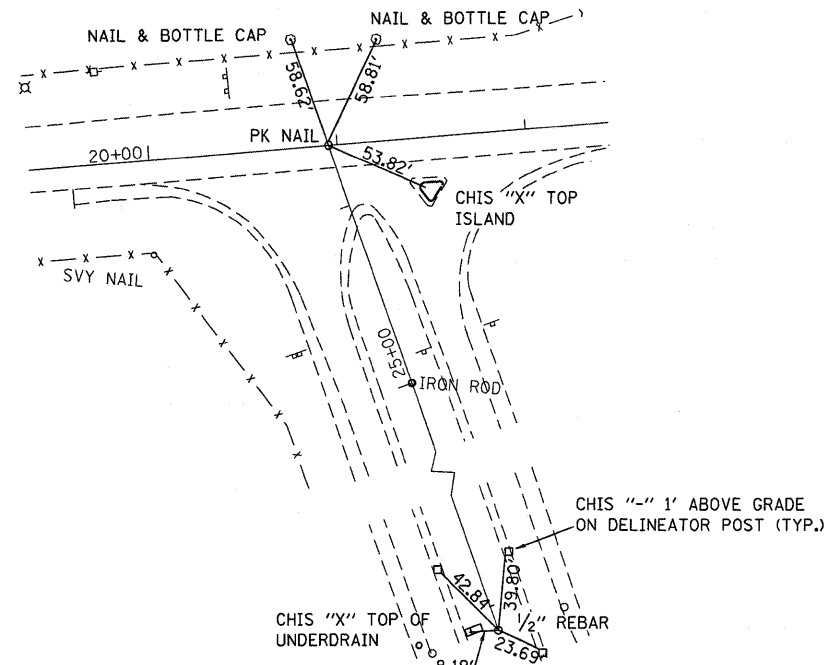

PNT 94 POT STA. 22+05.80

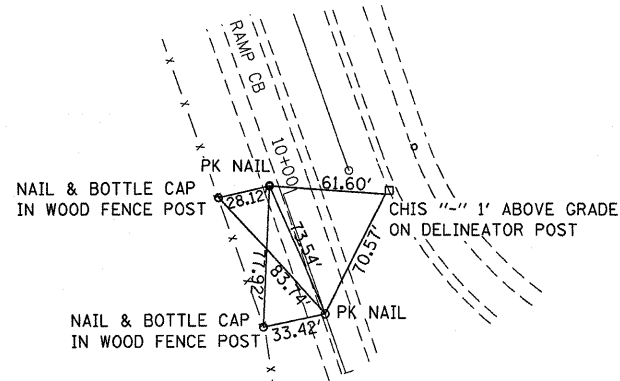

PNT 5002 INST STA. 22+12.38 42.35' LT
 PNT 22 PC STA. 10+67.05 CB

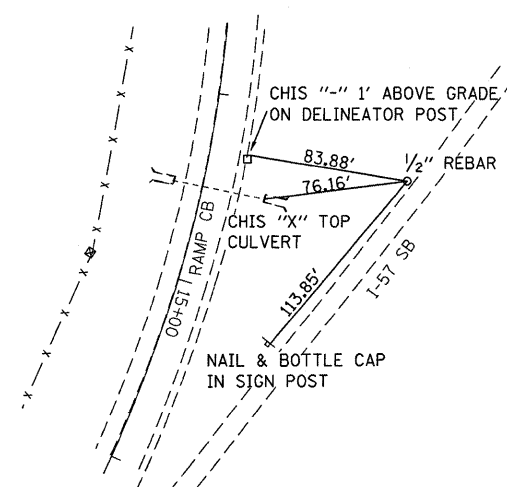

PNT 23 PI STA. 14+63.47 CB

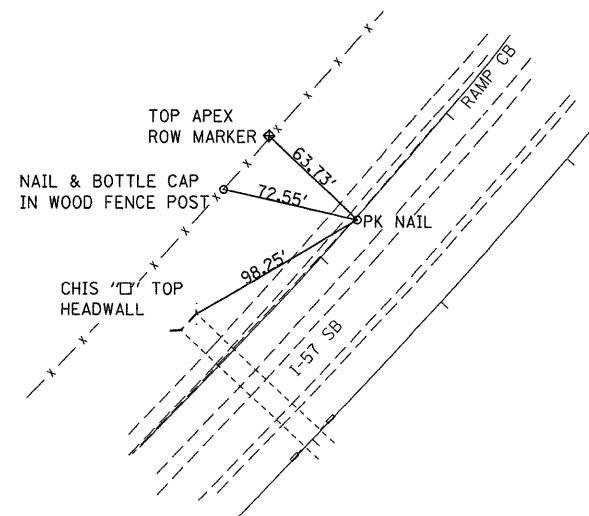

PNT 25 PI STA. 18+72.90 CB

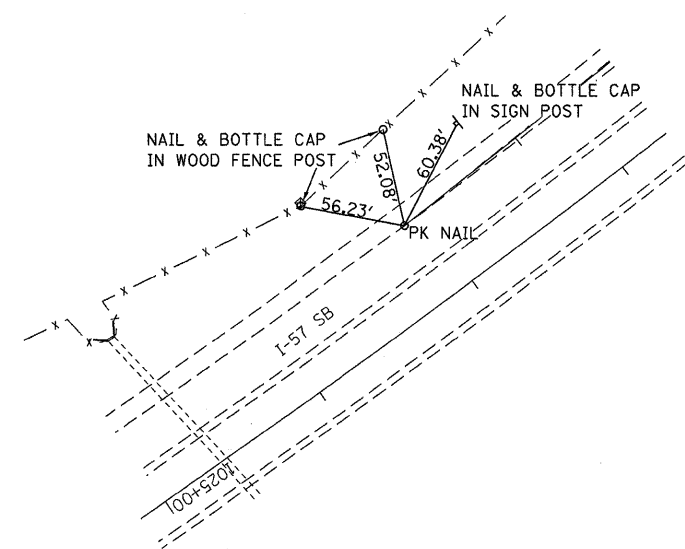

PNT 29 PT STA. 29+75 CB

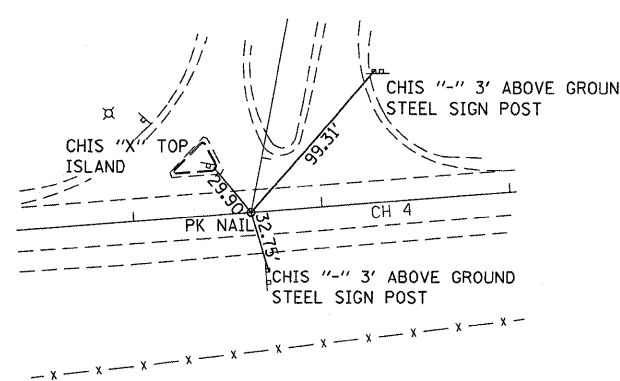

PNT 91 POT STA. 27+29.77 RAMP ME =
 PNT 100 POT STA. 36+62.36 CH 4

PNT 38 PC STA. 22+03.14 RAMP ME
 PNT 20 PI STA. 22+36.87 RAMP ME
 PNT 87 POT STA. 10+00 RAMP DA

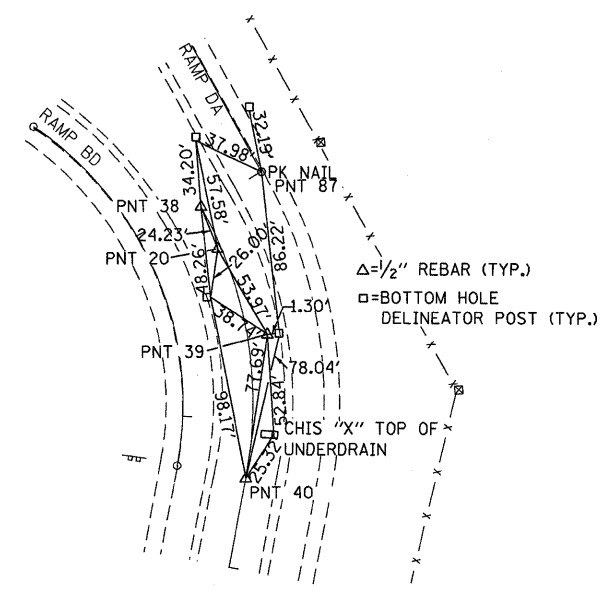

PNT 39 PI STA. 22+80.83 RAMP ME
 PNT 40 POT STA. 23+52.08 RAMP ME

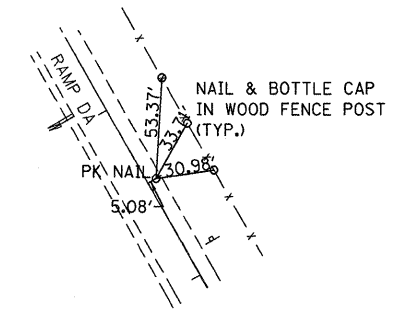

PNT 5003 INST STA. 11+55.35 4.93' RT

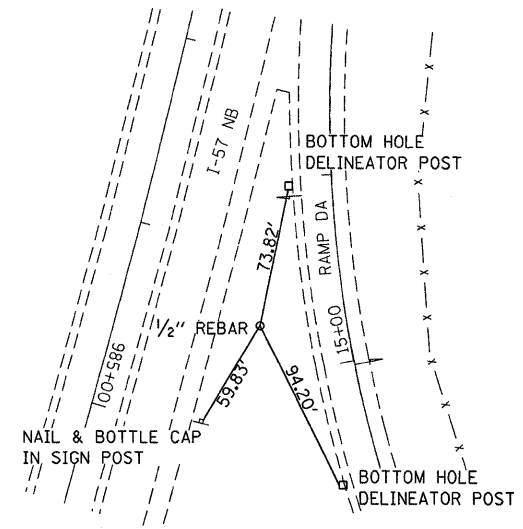

PNT 31 PI STA. 15+37.20 DA

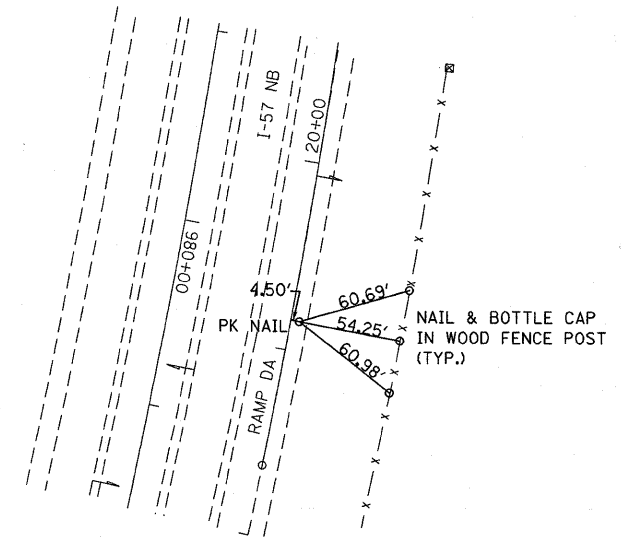

PNT 5006 INST STA. 19+15.61 3.60' RT DA

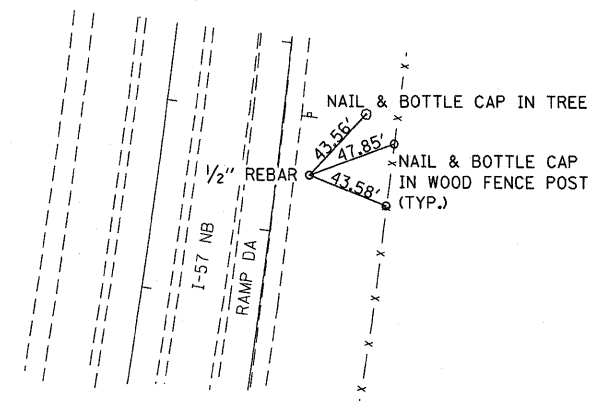

PNT 34 PI STA. 22+32.17 DA

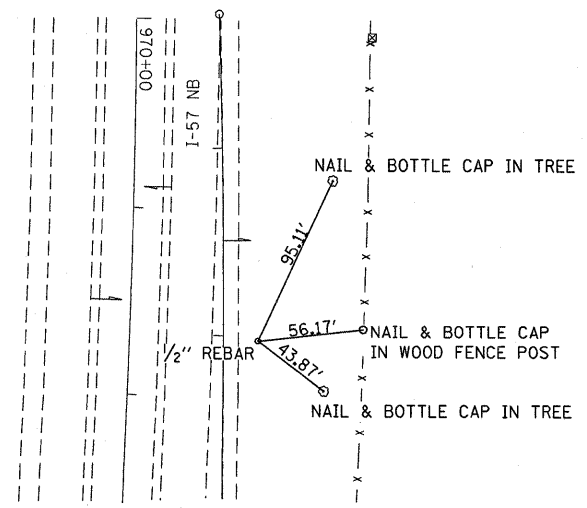

PNT 36 PI STA. 27+98.08 DA

FILE NAME =	USER NAME = duncanbd	DESIGNED -	REVISED -
ca:\pwork\pwidot\duncanbd\dms30392\ep5105-ah-ah-alignment-ties.dgn		DRAWN -	REVISED -
	PLOT SCALE = 50.0000' / IN.	CHECKED -	REVISED -
	PLOT DATE = Oct 21, 2009 - 8:34:24 AM	DATE -	REVISED -

**STATE OF ILLINOIS
 DEPARTMENT OF TRANSPORTATION**

ALIGNMENT & SURVEY TIES			
SCALE:	SHEET NO. OF SHEETS	STA. TO STA.	

F.A.I. RTE.	SECTION	COUNTY	TOTAL SHEETS	SHEET NO.
57	(38-1,2)RS-2 & I	IROQUOIS	263	19
				CONTRACT NO. 66981
ILLINOIS FED. AID PROJECT				